

quality . service  
innovation . integrity

# Duplex-N-Done Package



## Features

915-1000

- High performance without the high cost
- More dependability than a single-pump system
- State-of-the-art protection and increased peace of mind
- Easy and economical to install
- System includes: Two 1/2 HP, 115V grinder pumps, automatic alternator, multi-functional alarm system, two check valves (basin & piping not included)
- Ships in one carton
- Fits into existing 18x30 basins or retrofit (consult local codes)
- Operates from a single 115V, 15 amp circuit
- Minimum 24" diameter duplex basin recommended for new installations

## Specifications

### Motor Characteristics

Motor	1/2
Voltage	115
Phase	1 Ph
Hertz	60 Hz
RPM	3450
Type	Capacitor start/capacitor run
Insulation	Class B
Amps	7.0

### Pump Characteristics

Discharge Size	1-1/4" (NPT)
Cord Length	15' (5 m)
Cord Type	UL listed 3-wire plug
Max Head	26' (7.9 m)

### Materials Characteristics

Cap	Engineered plastic
Motor Housing	Engineered plastic
Pump Housing	Cast iron
Upper Bearing	Ball bearing
Lower Bearing	Ball bearing
Mechanical Seals	Carbon and ceramic
Impeller Type	Non-clogging vortex
Impeller	Engineered plastic
Hardware	Stainless steel
Motor Shaft	AISI 1215
Gasket	Buna-N pump O-ring

60 Hz



**PUMP COMPANY**

Zoeller Family of Water Solutions™

# Duplex-N-Done Package

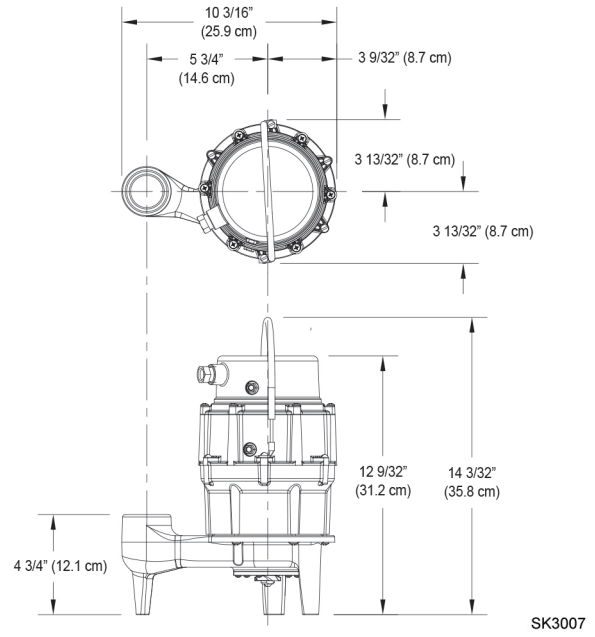
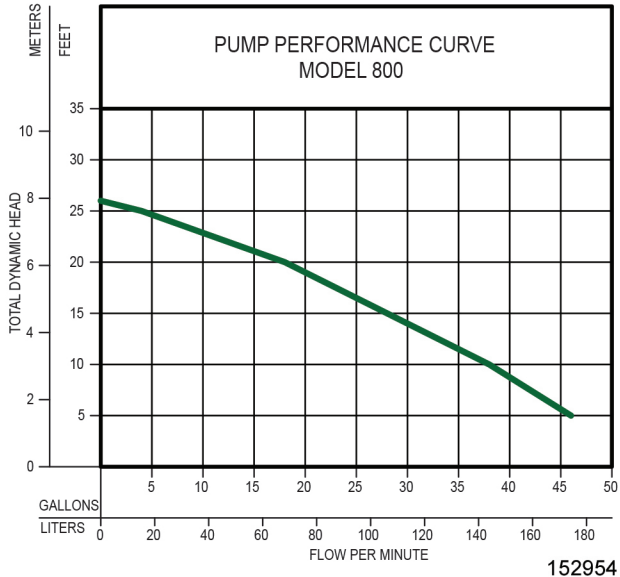

## Model

Model Number	Volts	Phase	HP	Hz
915-1000	115	1	1/2	60

**Your Peace of Mind is Our Top Priority®**  
 3649 Cane Run Rd | Louisville, KY 40211 USA  
 +1 502-778-2731 | 1-800-928-7867 | Fax: +1 502-774-3624  
[www.zoeller.com](http://www.zoeller.com)