

# Zehnder ComfoPost

User and installer manual

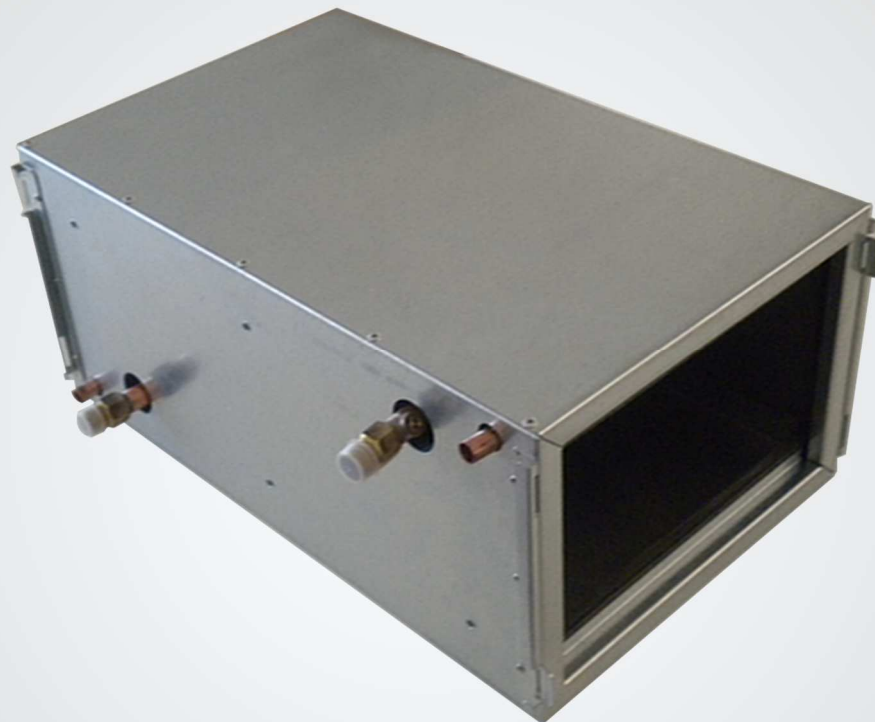

Version v1222 (december 2022)

All right reserved. This manual has been drawn up with the utmost care, however, it is not possible to hold the publisher responsible for any damage deriving from the lack or inaccuracy of the information provided in this manual.

# Table of Contents

1. Foreward.....	4
2. Introduction and safety .....	5
2.1 Introduction.....	5
2.2 Safety .....	5
2.3 Installation conditions.....	6
3. Description.....	5
3.1 Overview ComfoPost .....	6
3.2 Dimensional drawings .....	6
3.3 Performance of ComfoPost .....	7
3.4 Output ComfoPost CW6.....	8
3.5 Output ComfoPost CW8.....	9
3.6 Output ComfoPost CW10.....	10
3.7 Output ComfoPost CW12.....	11
4. Transport and installation.....	12
4.1 Safety instruction and transport.....	12
4.2 Check the delivery.....	12
4.3 Unpack the unit.....	12
4.4 Safety instructions installation .....	12
4.5 Allowed installation modes .....	12
4.5.1 Horizontal installation .....	13
4.5.2 Horizontal counter-flow installation .....	13
4.5.3 Vertical installation .....	13
4.6 NOT allowed installation modes .....	14
4.6.1 Do not install the ComfoPost with downward airflow .....	14
4.6.2 Do not connect the condensate drain at the top .....	14
4.6.3 Do not install the ComfoPost vertically with the hydraulic connections facing up or down .....	15
4.7 Installation .....	15
5. Miantenance .....	16



# 1. Foreward

**Please read this manual carefully before use.**

Carefully read this manual before use. With the help of this manual you can install, commission or carry out maintenance on Zehnder ComfoPost in a safe and optimal way.

The ComfoPost is hereinafter referred to as “the coil”. As the coil is subject to continuous development and improvement, your coil may deviate from the description in this manual. An up-to-date user and installer manual can be downloaded online.

**The following symbols are used in this manual:**

Symbol	Meaning
	Point of attention
	Risk of compromised performance or damage to the system
	Risk of personal injury

## ?! Questions

For all questions, you can contact you Zehnder office.

## Use of ComfoPost

- ComfoPost can only be used when it is properly installed according to the instruction in this manual.
- Children must not play with ComfoPost, and they must not clean and maintain the coil.
- The ComfoPost cannot be installed nor managed by children, persons with reduced physical, sensory or mental capabilities or lack of experience or knowledge.

## Warranty conditions

ComfoPost is covered by a manufacturer's warranty for a period of 24 months after fitting up to a maximum of 30 months after the date of manufacture.

Warranty claims may only be submitted for material faults and/or construction faults arising during the warranty period. In case of warranty claim, the coil must not be dismantled without written permission from the manufacturer.

The warranty conditions become invalid if:

- The warranty period has elapsed;
- The ventilation unit linked to ComfoPost works without filters or with not supplied by the manufacturer;
- The maintenance of ComfoPost and ventilation unit linked to ComfoPost is not regularly done;
- It's used a fluid different from water;
- The water is used to a pression upper than 2 bar;
- The installation takes palece in a place without the required conditions;
- The condensate drain does not take place correctly, due to non-pervince of the drain, freezing, unsuitable installation slope.

## 2. Introduction and safety

### 2.1 Introduction

Zehnder ComfoPost is a coil in which it runs hot water in winter (maximum 55°C) and cold water in summer (minimum 5°C).

It is installed on the supply pipe, after a mechanical ventilation unit and before the ComfoWell attenuator. It heats or cools and dehumidifies the supply air.

The mechanical ventilation unit with high efficiency energy recovery extracts humid and stale air from the service areas (bathrooms and kitchen) and introduces fresh air in the main areas (living room and bedrooms). Gaps under the doors ensure that there is airflow in the house.

The ventilation unit performs an initial passive pre-treatment of the air: during the winter period, if the energy exchanger is HRV type, it recovers only sensible heat. If the energy exchanger is ERV type, it recovers both sensible heat and humidity.

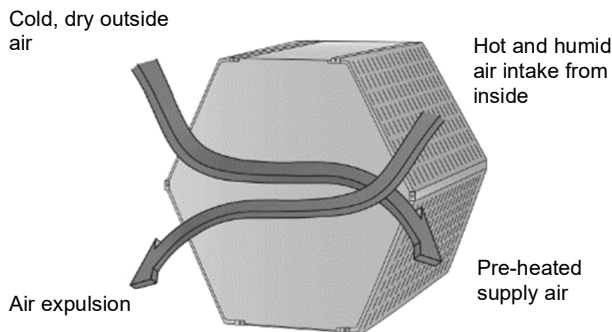

During the summer, the internal air is cooled and dehumidified by the air conditioning system, while the external air is very hot and very humid.

Only the sensitive temperature exchange is possible inside the HRV exchanger; this means that the extract air will cool the outside supply air, providing it pre-cooled but with the full amount of humidity.

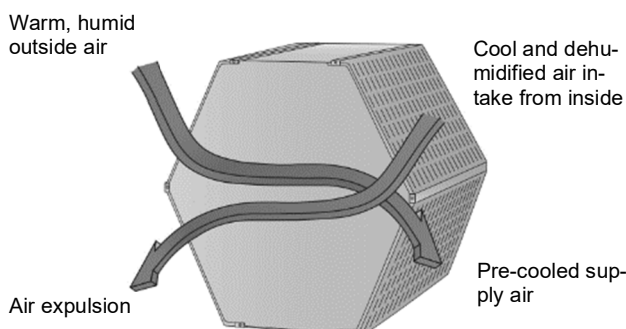

In the enthalpy exchanger (ERV), on the other hand, the membrane is able to exchange both heat and humidity. The return air, cooled and dehumidified by the cooling system, will lower both the temperature and the humidity contained in the external air, sending it into the internal environment passively pre-cooled and pre-dehumidified.

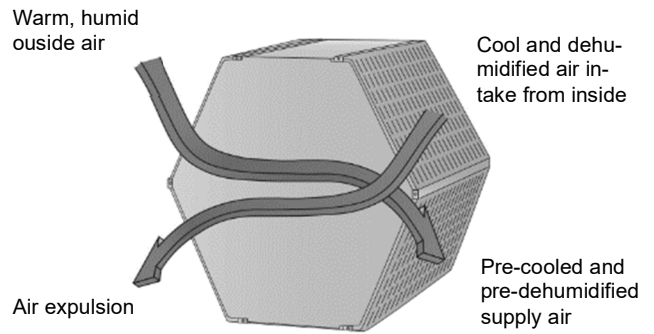

**It is recommended to use a mechanical ventilation unit with enthalpy exchanger (ERV) in combination with ComfoPost.**

The ComfoPost coil is installed on the delivery duct, after the controlled mechanical ventilation unit; in winter it heats, in summer it cools and dehumidifies the supply air.

The delivery pipes must be suitably insulated, to avoid the dispersion of heat in the winter and of cooling energy in the summer; it is also important to prevent surface condensation on the outside of the ComfoTube.

The system is completed by Zehnder regulation (ComfoPost Control and CA Control or Multi Control) and can be unique heating, cooling and dehumidification.

### 2.2 Safety

Zehnder ComfoPost is a simple water-air coil. It **must** be installed following the instructions given in this manual, inclined so as to facilitate the drainage of the condensate and connected to an inclined condensate evacuation system, free from obstructions, protected from freezing and such as to prevent the ascent of unpleasant odors, using a dry drain or siphon.



Wall or ceiling installation must be carried out with suitable dowels, on a support that can withstand the weight of the coil in operation. The execution must be in compliance with local building regulations.



Make the plumbing connections in accordance with local rules and regulations. Carry out a leak test before commissioning.



Connect the condensate drain in accordance with local rules and regulations. Carry out a patency and tightness test before commissioning, pouring more or more liters of water into the condensate drain and checking that they are correctly conveyed into the drain system without losses.

## 2.3 Installation conditions

To make a decision if the coil can be installed in a specific area, the next conditions must be obeyed to make sure that you install the unit correctly.



Zehnder ComfoPost is designed for use in residential or similar environments. It is not intended for use in commercial or artisan environments or in very humid environments such as swimming pools or saunas, environments in which there are corrosive substances or excessive dust.



Make sure that the coil installation environment stays within the allowable temperature range all year round. The permissible temperature for the installation site is between +7 e +40°C. Do not install the coil outdoors.



Make sure that the humidity inside the coil installation environment is not too high, to prevent the formation of condensation on the outside of the casing and, consequently, the formation of rust. Do not install the coil in bathrooms, swimming pools, sauna or outdoors.

Make sure there is enough space available at the installation site for:

- Insulated duct system;
- Carry out maintenance;
- The condensate drain;
- The hydronic supply and related control devices (valves).

## 3. Description

### 3.1 Overview ComfoPost

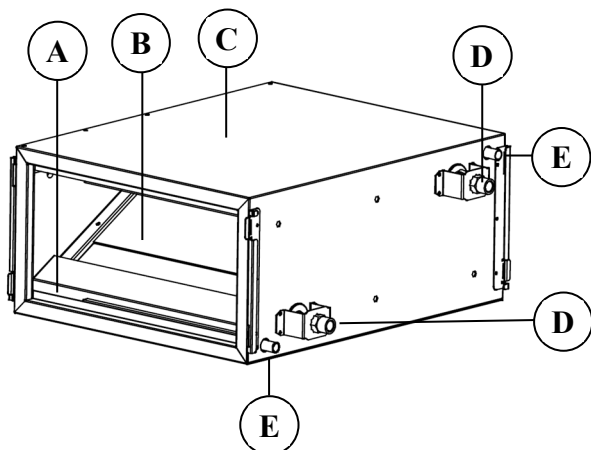

Position	Part
A	Condensate drain pan
B	Air/water battery
C	External cover, insulated stainless steel
D	Copper fittings for 1/2" hydronic pipes
E	Condensate drain 14 mm

## 3.2 Dimensional drawings

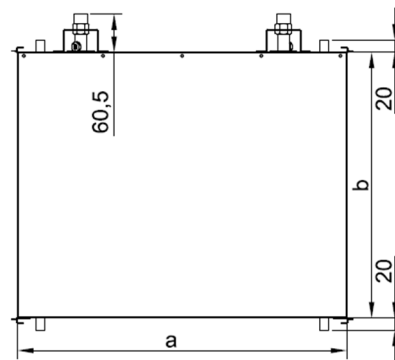

Top view

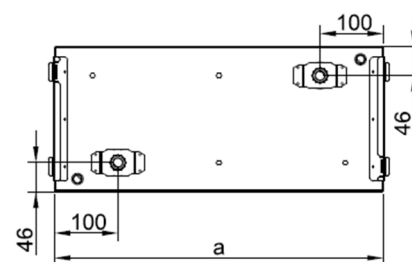

Front view



Side view

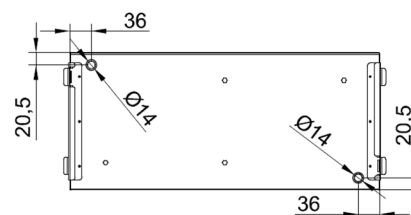

Rear view

Position	CW6	CW8	CW10	CW12
a [mm]	520	520	520	520
b [mm]	320	420	520	625
c [mm]	230	230	230	230

### 3.3 Performance of ComfoPost

The performance of ComfoPost coils is calculated according to the following criteria.

- Since the coil is connected to a ComfoWell of the same size, the air flow rates used refer to its flange plate, with all the pipes connected or all but one. The flow rates considered are both with DN 75 and DN 90 pipes.  
For example, for a CW8 coil, linked to ComfoWell CW8, 7 pipes DN 75 are considered (single pipe nominal flow rate: 30 m<sup>3</sup>/h, total nominal flow rate: 210 m<sup>3</sup>/h) or 8 pipes DN 75 (single pipe total nominal flow rate: 240 m<sup>3</sup>/h), 7 pipes DN 90 (single pipe nominal flow rate: 50 m<sup>3</sup>/h, total nominal flow rate: 350 m<sup>3</sup>/h) or 8 pipes DN 90 (total nominal flow rate: 400 m<sup>3</sup>/h).
- The temperature and humidity of the external air in winter are considered equal to 2°C – 70% R.H., the temperature and humidity of internal air are equal to 20°C with 60% R.H.
- The temperature and humidity at the coil inlet, in winter, are in the outlet conditions of a ComfoAir Q ventilation unit with HRV exchanger (18°C – 25%) or with ERV exchanger (17°C – 60%), calculated following the results of the PHI certificates.
- The inlet water temperature in winter is considered from 40° to 55°C with steps of 5°C.



Do not use temperature hotter than 55°C.

- The temperature and the humidity of the external air during the summer season are considered equal to 35°C – 50% R.H., the temperature and the humidity of the internal air are equal to 25°C – 50% R.H.
- The temperature and the humidity at the coil inlet, in summer season, are in the outlet conditions of a ComfoAir Q ventilation unit with HRV exchanger (27°C – 80%) or with an ERV exchanger (28°C – 55%), calculated following the results of the PHI “Warm Climate” certificates.
- The temperature of the inlet water in summer is considered at 7°C, the ideal temperature for performing good dehumidification of the supply air.



The dehumidification capacity is indicated in l/h at the internal and external conditions described above.



Check that the supply water flow rate is correct

### 3.4 Output ComfoPost CW6

Air conditions IN		T	18 °C				17 °C				27°C	28°C
		RH	25 %				60 %				80 %	55 %
		AH	3,2 g/kg				7,3 g/kg				18,1 g/kg	13,1 g/kg
Water temperature IN		°C	55	50	45	40	55	50	45	40	7	7
Air Flow 150 m <sup>3</sup> /h (5 ComfoTube DN75)	H <sub>2</sub> O flow	l/h	600				600				600	600
	H <sub>2</sub> O <sub>OUT</sub> temperature	°C	52	48	43	39	52	48	43	38	10	10
	ΔP H <sub>2</sub> O	kPa	9	10	10	10	9	10	10	10	12	12
	AIR temperature <sub>OUT</sub>	°C	53	48	43	38	52	47	43	38	12	11
	Air RH <sub>OUT</sub>	%	3,8	4,7	6,0	7,7	8,5	10,8	13,6	17,5	100	96
	Air AH <sub>OUT</sub>	g/kg	3,2	3,2	3,2	3,2	7,3	7,3	7,3	7,3	9,1	7,9
	Air ΔP	Pa	9,3	9,1	9,0	8,9	9,3	9,2	9,1	9,0	17,5	13,2
	Condensation	l/h	-	-	-	-	-	-	-	-	1,70	1,00
	SENSIBLE POWER	kW	-	-	-	-	-	-	-	-	0,74	0,86
	<b>TOTAL POWER</b>	<b>kW</b>	<b>1,73</b>	<b>1,50</b>	<b>1,26</b>	<b>1,03</b>	<b>1,79</b>	<b>1,55</b>	<b>1,32</b>	<b>1,08</b>	<b>1,88</b>	<b>1,52</b>
Air Flow 180 m <sup>3</sup> /h (6 ComfoTube DN75)	H <sub>2</sub> O flow	l/h	600				600				600	600
	H <sub>2</sub> O <sub>OUT</sub> temperature	°C	52	47	43	38	52	47	43	38	9	9
	ΔP H <sub>2</sub> O	kPa	9	10	10	10	9	10	10	10	12	12
	AIR temperature <sub>OUT</sub>	°C	51	47	42	38	51	47	42	38	13	12
	Air RH <sub>OUT</sub>	%	3,9	4,9	6,2	7,9	8,9	11,2	14,2	18,0	100	94
	Air AH <sub>OUT</sub>	g/kg	3,2	3,2	3,2	3,2	7,3	7,3	7,3	7,3	9,6	8,2
	Air ΔP	Pa	11,6	11,4	11,3	11,2	11,6	11,5	11,4	11,2	22	16,5
	Condensation	l/h	-	-	-	-	-	-	-	-	1,8	1,1
	SENSIBLE POWER	kW	-	-	-	-	-	-	-	-	0,85	0,97
	<b>TOTAL POWER</b>	<b>kW</b>	<b>2,02</b>	<b>1,75</b>	<b>1,47</b>	<b>1,20</b>	<b>2,09</b>	<b>1,81</b>	<b>1,54</b>	<b>1,26</b>	<b>2,12</b>	<b>1,72</b>

Air conditions IN		T	18 °C				17 °C				27°C	28°C
		RH	25 %				60 %				80 %	55 %
		AH	3,2 g/kg				7,3 g/kg				18,1 g/kg	13,1 g/kg
Water temperature IN		°C	55	50	45	40	55	50	45	40	7	7
Air Flow 250 m <sup>3</sup> /h (5 ComfoTube DN90)	H <sub>2</sub> O flow	l/h	600				600				600	600
	H <sub>2</sub> O <sub>OUT</sub> temperature	°C	52	47	43	38	51	47	42	38	11	10
	ΔP H <sub>2</sub> O	kPa	10	10	10	10	10	10	10	10	12	12
	AIR temperature <sub>OUT</sub>	°C	51	46	42	37	49	45	41	36	15	14
	Air RH <sub>OUT</sub>	%	4	5	7	9	10	12	15	19	99	91
	Air AH <sub>OUT</sub>	g/kg	3,2	3,2	3,2	3,2	7,3	7,3	7,3	7,3	10,8	8,9
	Air ΔP	Pa	18	18	18	18	18	18	18	18	34	25
	Condensation	l/h	-	-	-	-	-	-	-	-	2,2	1,3
	SENSIBLE POWER	kW	-	-	-	-	-	-	-	-	1,05	1,2
	<b>TOTAL POWER</b>	<b>kW</b>	<b>2,65</b>	<b>2,28</b>	<b>1,92</b>	<b>1,56</b>	<b>2,73</b>	<b>2,36</b>	<b>2,00</b>	<b>1,64</b>	<b>2,55</b>	<b>2,11</b>
Air Flow 300 m <sup>3</sup> /h (6 ComfoTube DN90)	H <sub>2</sub> O flow	l/h	600				600				600	600
	H <sub>2</sub> O <sub>OUT</sub> temperature	°C	51	46	42	37	51	47	42	38	11	10
	ΔP H <sub>2</sub> O	kPa	10	10	10	10	10	10	10	10	12	12
	AIR temperature <sub>OUT</sub>	°C	48	44	40	36	48	43	39	35	16	15
	Air RH <sub>OUT</sub>	%	5	6	7	9	10	12	15	19	99	90
	Air AH <sub>OUT</sub>	g/kg	3,2	3,2	3,2	3,2	7,3	7,3	7,3	7,3	11,4	9,3
	Air ΔP	Pa	23	23	23	22	23	23	23	22	44	32
	Condensation	l/h	-	-	-	-	-	-	-	-	2,4	1,4
	SENSIBLE POWER	kW	-	-	-	-	-	-	-	-	1,12	1,36
	<b>TOTAL POWER</b>	<b>kW</b>	<b>3,03</b>	<b>2,62</b>	<b>2,20</b>	<b>1,79</b>	<b>3,13</b>	<b>2,71</b>	<b>2,29</b>	<b>1,88</b>	<b>2,80</b>	<b>2,34</b>

### 3.5 Output ComfoPost CW8

Air conditions IN		T	18 °C				17 °C				27°C	28°C
		RH	25 %				60 %				80 %	55 %
		AH	3,2 g/kg				7,3 g/kg				18,1 g/kg	13,1 g/kg
Water temperature IN		°C	55	50	45	40	55	50	45	40	7	7
Air Flow 210 m <sup>3</sup> /h (7 Comfo Tube DN75)	H <sub>2</sub> O flow	l/h	600				600				600	600
	H <sub>2</sub> O <sub>OUT</sub> temperature	°C	52	47	43	38	51	47	42	38	11	10
	ΔP H <sub>2</sub> O	kPa	11	11	11	11	11	11	11	12	14	14
	AIR temperature <sub>OUT</sub>	°C	52	48	43	38	52	47	43	38	13	11
	Air RH <sub>OUT</sub>	%	3,8	4,8	6,0	7,7	8,6	10,8	13,7	17,5	100	95,6
	Air AH <sub>OUT</sub>	g/kg	3,2	3,2	3,2	3,2	7,3	7,3	7,3	7,3	9,2	8,0
	Air ΔP	Pa	8,9	8,8	8,7	8,6	9,0	8,8	8,7	8,6	16,8	12,7
	Condensation	l/h	-	-	-	-	-	-	-	-	2,3	1,3
	SENSIBLE POWER	kW	-	-	-	-	-	-	-	-	1,02	1,21
	<b>TOTAL POWER</b>	<b>kW</b>	<b>2,42</b>	<b>2,09</b>	<b>1,76</b>	<b>1,43</b>	<b>2,50</b>	<b>2,17</b>	<b>1,84</b>	<b>1,51</b>	<b>2,60</b>	<b>2,11</b>
Air Flow 240 m <sup>3</sup> /h (8 Comfo Tube DN75)	H <sub>2</sub> O flow	l/h	600				600				600	600
	H <sub>2</sub> O <sub>OUT</sub> temperature	°C	51	47	42	38	51	46	42	38	11	10
	ΔP H <sub>2</sub> O	kPa	11	11	11	12	11	11	11	11	14	14
	AIR temperature <sub>OUT</sub>	°C	51	47	42	38	51	47	42	38	13	12
	Air RH <sub>OUT</sub>	%	3,9	4,9	6,2	7,9	8,9	11,1	14,1	17,9	100	94,7
	Air AH <sub>OUT</sub>	g/kg	3,2	3,2	3,2	3,2	7,3	7,3	7,3	7,3	9,6	8,2
	Air ΔP	Pa	10,5	10,4	10,2	10,1	10,5	10,4	10,3	10,2	19,9	14,9
	Condensation	l/h	-	-	-	-	-	-	-	-	2,5	1,4
	SENSIBLE POWER	kW	-	-	-	-	-	-	-	-	1,11	1,32
	<b>TOTAL POWER</b>	<b>kW</b>	<b>2,71</b>	<b>2,34</b>	<b>1,97</b>	<b>1,60</b>	<b>2,80</b>	<b>2,43</b>	<b>2,06</b>	<b>1,69</b>	<b>2,83</b>	<b>2,30</b>

Air conditions IN		T	18 °C				17 °C				27°C	28°C
		RH	25 %				60 %				80 %	55 %
		AH	3,2 g/kg				7,3 g/kg				18,1 g/kg	13,1 g/kg
Water temperature IN		°C	55	50	45	40	55	50	45	40	7	7
Air Flow 350 m <sup>3</sup> /h (7 Comfo Tube DN90)	H <sub>2</sub> O flow	l/h	600				600				600	600
	H <sub>2</sub> O <sub>OUT</sub> temperature	°C	50	45	41	40	50	45	41	37	12	12
	ΔP H <sub>2</sub> O	kPa	11	11	12	12	11	11	12	12	14	14
	AIR temperature <sub>OUT</sub>	°C	49	45	41	36	49	45	40	36	16	14
	Air RH <sub>OUT</sub>	%	5	5	7	9	10	13	16	20	99	91
	Air AH <sub>OUT</sub>	g/kg	3,2	3,2	3,2	3,2	7,3	7,3	7,3	7,3	11,0	9,1
	Air ΔP	Pa	17	17	17	17	17	17	17	17	33	39
	Condensation	l/h	-	-	-	-	-	-	-	-	3,0	3,2
	SENSIBLE POWER	kW	-	-	-	-	-	-	-	-	1,4	1,7
	<b>TOTAL POWER</b>	<b>kW</b>	<b>3,68</b>	<b>3,17</b>	<b>2,67</b>	<b>2,17</b>	<b>3,79</b>	<b>3,28</b>	<b>2,78</b>	<b>2,28</b>	<b>3,48</b>	<b>2,89</b>
Air Flow 400 m <sup>3</sup> /h (8 Comfo Tube DN90)	H <sub>2</sub> O flow	l/h	600				600				600	600
	H <sub>2</sub> O <sub>OUT</sub> temperature	°C	49	45	41	37	49	45	41	38	11	11
	ΔP H <sub>2</sub> O	kPa	11	11	12	12	11	11	12	12	14	14
	AIR temperature <sub>OUT</sub>	°C	48	44	40	36	48	44	40	35	16	15
	Air RH <sub>OUT</sub>	%	5	6	7	9	11	13	16	20	99	90
	Air AH <sub>OUT</sub>	g/kg	3,2	3,2	3,2	3,2	7,3	7,3	7,3	7,3	11,4	9,3
	Air ΔP	Pa	21	21	20	20	21	21	20	20	25	29
	Condensation	l/h	-	-	-	-	-	-	-	-	1,7	1,8
	SENSIBLE POWER	kW	-	-	-	-	-	-	-	-	1,5	1,8
	<b>TOTAL POWER</b>	<b>kW</b>	<b>4,06</b>	<b>3,50</b>	<b>2,95</b>	<b>2,40</b>	<b>4,18</b>	<b>3,63</b>	<b>3,07</b>	<b>2,51</b>	<b>3,73</b>	<b>3,11</b>

### 3.6 Output ComfoPost CW10

Air conditions IN		T	18 °C				17 °C				27°C	28°C
		RH	25 %				60 %				80 %	55 %
		AH	3,2 g/kg				7,3 g/kg				18,1 g/kg	13,1 g/kg
Water temperature IN		°C	55	50	45	40	55	50	45	40	7	7
Air Flow 270 m <sup>3</sup> /h (9 ComfoTube DN75)	H <sub>2</sub> O flow	l/h	600				600				600	600
	H <sub>2</sub> O <sub>OUT</sub> temperature	°C	51	46	42	37	50	46	42	37	12	11
	ΔP H <sub>2</sub> O	kPa	12	12	13	13	12	13	13	13	15	15
	AIR temperature <sub>OUT</sub>	°C	52	47	43	38	52	47	43	38	13	11
	Air RH <sub>OUT</sub>	%	3,8	4,8	6,1	7,8	8,6	10,9	13,8	17,6	100	96
	Air AH <sub>OUT</sub>	g/kg	3,2	3,2	3,2	3,2	7,3	7,3	7,3	7,3	9,4	8,1
	Air ΔP	Pa	9	9	9	8	9	9	9	8	17	12
	Condensation	l/h	-	-	-	-	-	-	-	-	2,9	1,7
	SENSIBLE POWER	kW	-	-	-	-	-	-	-	-	1,28	1,52
	<b>TOTAL POWER</b>	<b>kW</b>	<b>3,10</b>	<b>2,67</b>	<b>2,25</b>	<b>1,83</b>	<b>3,20</b>	<b>2,78</b>	<b>2,35</b>	<b>1,93</b>	<b>3,27</b>	<b>2,66</b>
Air Flow 300 m <sup>3</sup> /h (10 ComfoTube DN75)	H <sub>2</sub> O flow	l/h	600				600				600	600
	H <sub>2</sub> O <sub>OUT</sub> temperature	°C	50	46	41	37	50	46	41	37	12	11
	ΔP H <sub>2</sub> O	kPa	12	13	13	13	12	12	13	13	15	16
	AIR temperature <sub>OUT</sub>	°C	51	47	42	38	51	47	42	38	14	12
	Air RH <sub>OUT</sub>	%	3,9	4,9	6,2	7,9	8,9	11,2	14,1	17,9	100	95
	Air AH <sub>OUT</sub>	g/kg	3,2	3,2	3,2	3,2	7,3	7,3	7,3	7,3	9,8	8,3
	Air ΔP	Pa	10	10	10	10	10	10	10	10	19	14
	Condensation	l/h	-	-	-	-	-	-	-	-	3,0	1,8
	SENSIBLE POWER	kW	-	-	-	-	-	-	-	-	1,36	1,8
	<b>TOTAL POWER</b>	<b>kW</b>	<b>3,38</b>	<b>2,92</b>	<b>2,46</b>	<b>2,00</b>	<b>3,50</b>	<b>3,03</b>	<b>2,57</b>	<b>2,11</b>	<b>3,48</b>	<b>2,85</b>

Air conditions IN		T	18 °C				17 °C				27°C	28°C
		RH	25 %				60 %				80 %	55 %
		AH	3,2 g/kg				7,3 g/kg				18,1 g/kg	13,1 g/kg
Water temperature IN		°C	55	50	45	40	55	50	45	40	7	7
Air Flow 450 m <sup>3</sup> /h (9 ComfoTube DN90)	H <sub>2</sub> O flow	l/h	600				600				600	600
	H <sub>2</sub> O <sub>OUT</sub> temperature	°C	48	44	40	36	48	44	40	36	13	12
	ΔP H <sub>2</sub> O	kPa	13	13	13	13	13	13	13	13	16	16
	AIR temperature <sub>OUT</sub>	°C	49	45	40	36	48	44	40	36	16	14
	Air RH <sub>OUT</sub>	%	5	6	7	9	10	13	16	20	99	91
	Air AH <sub>OUT</sub>	g/kg	3,2	3,2	3,2	3,2	7,3	7,3	7,3	7,3	11,2	9,17
	Air ΔP	Pa	17	17	17	16	17	17	17	16	32	24
	Condensation	l/h	-	-	-	-	-	-	-	-	3,7	2,1
	SENSIBLE POWER	kW	-	-	-	-	-	-	-	-	1,74	2,14
	<b>TOTAL POWER</b>	<b>kW</b>	<b>4,68</b>	<b>4,04</b>	<b>3,40</b>	<b>2,76</b>	<b>4,82</b>	<b>4,18</b>	<b>3,54</b>	<b>2,90</b>	<b>4,33</b>	<b>3,62</b>
Air Flow 500 m <sup>3</sup> /h (10 ComfoTube DN90)	H <sub>2</sub> O flow	l/h	600				600				600	600
	H <sub>2</sub> O <sub>OUT</sub> temperature	°C	48	44	40	36	47	44	40	36	14	12
	ΔP H <sub>2</sub> O	kPa	13	13	13	13	13	13	13	13	16	16
	AIR temperature <sub>OUT</sub>	°C	48	44	40	36	48	44	39	35	16	15
	Air RH <sub>OUT</sub>	%	5	6	7	9	11	13	16	20	99	90
	Air AH <sub>OUT</sub>	g/kg	3,2	3,2	3,2	3,2	7,3	7,3	7,3	7,3	11,6	9,4
	Air ΔP	Pa	19	19	19	19	19	19	19	19	37	27
	Condensation	l/h	-	-	-	-	-	-	-	-	3,9	2,2
	SENSIBLE POWER	kW	-	-	-	-	-	-	-	-	1,83	2,30
	<b>TOTAL POWER</b>	<b>kW</b>	<b>5,06</b>	<b>4,37</b>	<b>3,67</b>	<b>2,98</b>	<b>5,21</b>	<b>4,52</b>	<b>3,82</b>	<b>3,13</b>	<b>4,57</b>	<b>3,82</b>

### 3.7 Output ComfoPost CW12

Air conditions IN		T	18 °C				17 °C				27°C	28°C
		RH	25 %				60 %				80 %	55 %
		AH	3,2 g/kg				7,3 g/kg				18,1 g/kg	13,1 g/kg
Water temperature IN		°C	55	50	45	40	55	50	45	40	7	7
Air Flow 330 m <sup>3</sup> /h (11 Comfo Tube DN75)	H <sub>2</sub> O flow	l/h	600				600				600	600
	H <sub>2</sub> O <sub>OUT</sub> temperature	°C	49	45	41	37	49	45	41	37	13	12
	ΔP H <sub>2</sub> O	kPa	15	16	16	16	15	15	16	16	19	19
	AIR temperature <sub>OUT</sub>	°C	52	48	43	38	52	48	43	38	13	11
	Air RH <sub>OUT</sub>	%	4	5	6	8	8	11	14	17	100	96
	Air AH <sub>OUT</sub>	g/kg	3,2	3,2	3,2	3,2	7,3	7,3	7,3	7,3	9,2	8,0
	Air ΔP	Pa	6,9	6,9	6,8	6,7	7,0	7,0	6,8	6,7	13,1	9,8
	Condensation	l/h	-	-	-	-	-	-	-	-	3,5	2,1
	SENSIBLE POWER	kW	-	-	-	-	-	-	-	-	1,6	1,9
	<b>TOTAL POWER</b>	<b>kW</b>	<b>3,84</b>	<b>3,32</b>	<b>2,79</b>	<b>2,27</b>	<b>3,97</b>	<b>3,44</b>	<b>2,92</b>	<b>2,39</b>	<b>4,09</b>	<b>3,32</b>
Air Flow 360 m <sup>3</sup> /h (12 Comfo Tube DN75)	H <sub>2</sub> O flow	l/h	600				600				600	600
	H <sub>2</sub> O <sub>OUT</sub> temperature	°C	49	45	41	36	49	45	40	36	13	12
	ΔP H <sub>2</sub> O	kPa	15	15	16	16	15	15	16	16	19	19
	AIR temperature <sub>OUT</sub>	°C	52	47	43	38	52	47	43	38	13	12
	Air RH <sub>OUT</sub>	%	3,8	4,8	6,1	7,7	8,6	10,8	13,7	17,5	100	95,83
	Air AH <sub>OUT</sub>	g/kg	3,2	3,2	3,2	3,2	7,3	7,3	7,3	7,3	9,5	8,1
	Air ΔP	Pa	7,7	7,6	7,5	7,4	7,7	7,6	7,5	7,4	14,5	10,9
	Condensation	l/h	-	-	-	-	-	-	-	-	3,7	2,2
	SENSIBLE POWER	kW	-	-	-	-	-	-	-	-	1,69	2,01
	<b>TOTAL POWER</b>	<b>kW</b>	<b>4,14</b>	<b>3,57</b>	<b>3,01</b>	<b>2,45</b>	<b>4,27</b>	<b>3,71</b>	<b>3,14</b>	<b>2,58</b>	<b>4,31</b>	<b>3,52</b>

Air conditions IN		T	18 °C				17 °C				27°C	28°C
		RH	25 %				60 %				80 %	55 %
		AH	3,2 g/kg				7,3 g/kg				18,1 g/kg	13,1 g/kg
Water temperature IN		°C	55	50	45	40	55	50	45	40	7	7
Air Flow 550 m <sup>3</sup> /h (11 Comfo Tube DN90)	H <sub>2</sub> O flow	l/h	600				600				600	600
	H <sub>2</sub> O <sub>OUT</sub> temperature	°C	46	43	39	35	46	42	38	35	15	14
	ΔP H <sub>2</sub> O	kPa	16	16	16	16	16	16	16	16	19	19
	AIR temperature <sub>OUT</sub>	°C	49	45	41	36	49	45	40	36	16	14
	Air RH <sub>OUT</sub>	%	4	5	7	8	10	12	15	19	99	93
	Air AH <sub>OUT</sub>	g/kg	3,2	3,2	3,2	3,2	7,3	7,3	7,3	7,3	11,1	9,1
	Air ΔP	Pa	14	14	13	13	14	14	13	13	25	18
	Condensation	l/h	-	-	-	-	-	-	-	-	4,7	2,6
	SENSIBLE POWER	kW	-	-	-	-	-	-	-	-	2,17	2,67
	<b>TOTAL POWER</b>	<b>kW</b>	<b>5,91</b>	<b>5,11</b>	<b>4,30</b>	<b>3,50</b>	<b>6,10</b>	<b>5,29</b>	<b>4,48</b>	<b>3,67</b>	<b>5,41</b>	<b>4,52</b>
Air Flow 600 m <sup>3</sup> /h (12 Comfo Tube DN90)	H <sub>2</sub> O flow	l/h	600				600				600	600
	H <sub>2</sub> O <sub>OUT</sub> temperature	°C	46	42	38	35	46	42	38	34	15	14
	ΔP H <sub>2</sub> O	kPa	16	16	16	16	16	16	16	16	19	19
	AIR temperature <sub>OUT</sub>	°C	48	44	40	36	48	44	40	36	16	14
	Air RH <sub>OUT</sub>	%	5	6	7	9	10	13	16	20	99	92
	Air AH <sub>OUT</sub>	g/kg	3,2	3,2	3,2	3,2	7,3	7,3	7,3	7,3	11,3	9,3
	Air ΔP	Pa	15	15	15	15	15	15	15	15	29	20
	Condensation	l/h	-	-	-	-	-	-	-	-	4,8	2,7
	SENSIBLE POWER	kW	-	-	-	-	-	-	-	-	2,26	2,84
	<b>TOTAL POWER</b>	<b>kW</b>	<b>6,30</b>	<b>5,44</b>	<b>4,59</b>	<b>3,73</b>	<b>6,51</b>	<b>5,64</b>	<b>4,78</b>	<b>3,92</b>	<b>5,64</b>	<b>4,73</b>

## 4. Transport and installation

### 4.1 Safety instruction and transport



Read the safety information and instructions before you transport the ComfoPost.



Always obey the local applicable construction, safety and installation laws and regulation.



The edges of the coil may be sharp. Use protective gloves to prevent cutting injuries.



Always handle the ComfoPost with two persons.



During transport, unpacking and installation operations pay attention not to bend or damage the condensate drains and the fittings for connecting the supply water pipes.



Be sure to follow the diagrams in this manual for installation.



The permitted temperature range for storage and transport is from 0°C to +50 °C.



Dispose of the packing material in an environmentally friendly manner.

### 4.2 Check the delivery



Contact your supplier directly in case of damage or missing items.

The box must contain:

- The ComfoPost coil;
- Quick installation guide IT/EN;
- 4 mounting brackets.



Check the identification type plate to make sure you have received the correct coil type.

### 4.3 Unpack the unit



Place the pack on a stable surface and open the box.



Be careful with handling the coil: do not hold it by the condensate drain fittings or by the water piping connections, they could bend or break.



Keep the quick installation guide and this manual near the battery.

### 4.4 Safety instructions installation

Make sure that in the installation site are arranged in advance:

- Insulated duct system;
- The condensate drain;
- The hydronic supply and related control devices (valves);
- Possible electrical power supply for the control valve.



Zehnder ComfoPost is designed for use in residential environment. It is not intended for use in commercial or artisan or very humid environments such as swimming pools or saunas, or in which there are corrosive substances or excessive dust.



Make sure that the coil installation environment stays within the allowable temperature range all year round. The allowed temperature is between +7 and +40°C. Do not install the coil outdoors.



Make sure that the humidity inside the coil installation environment is not too high, to prevent the formation of condensation on the casing and, consequently, the formation of rust. Do not install the coil in bathrooms, swimming pools, saunas or outdoor.



Make sure that the support on which the coil is installed is able to support its weight in operation. Use suitable fastening system.

### 4.5 Allowed installation modes

The ComfoPost coil can be installed in three different ways, anchored to the ceiling or fixed to the wall, connecting it directly to the ComfoWell or using ComfoWell plate to connect it to the insulated central piping (ComfoPipe Compact or ComfoPipe Plus).



The installation outside these modes causes the system to malfunction, as it is impossible to drain the condensate correctly.

#### 4.5.1 Horizontal installation

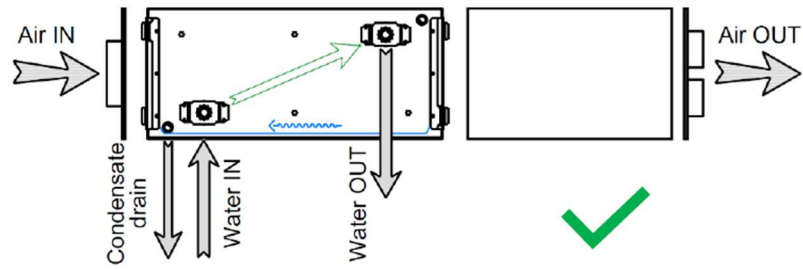

#### 4.5.2 Horizontal counter-flow installation

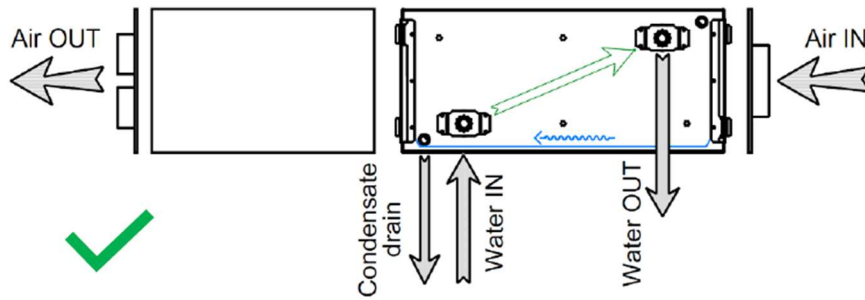

#### 4.5.3 Vertical installation

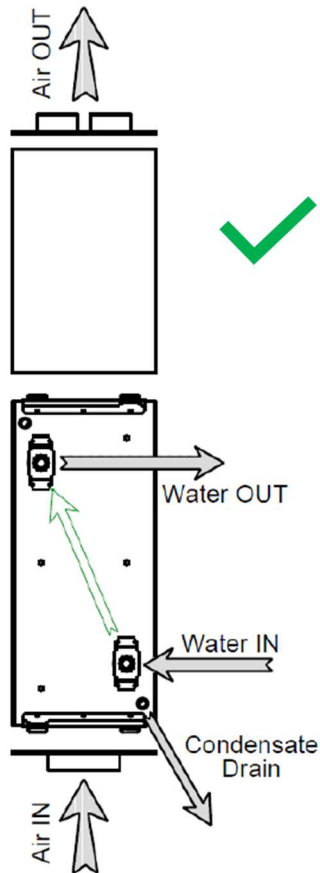

## 4.6 **NOT** allowed installation modes

### 4.6.1 Do not install the ComfoPost with downward airflow

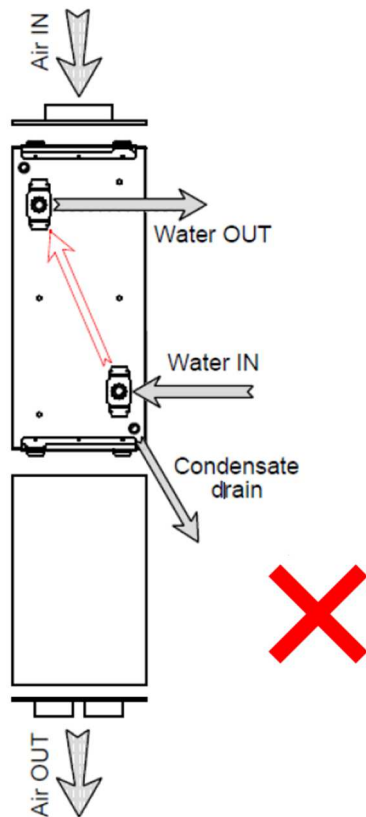

### 4.6.2 Do not connect the condensate drain at the top

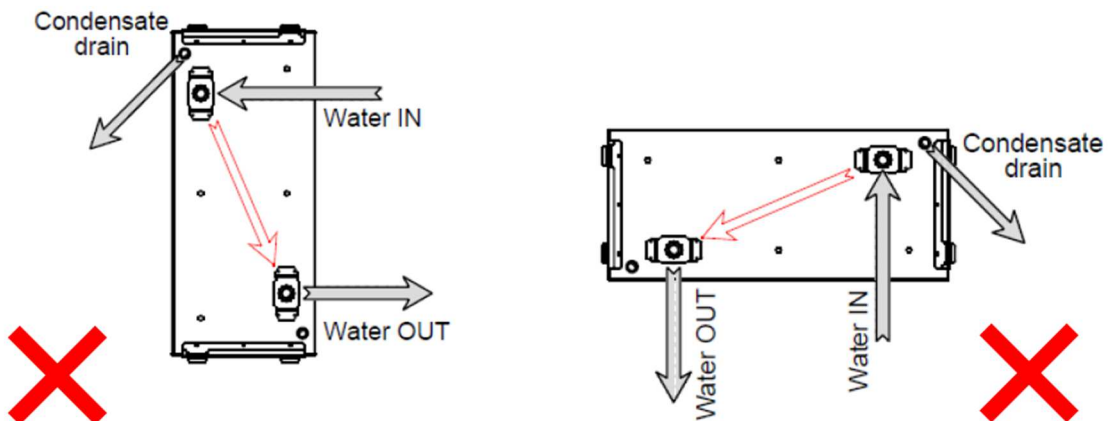

#### 4.6.3 Do not install the ComfoPost vertically with the hydraulic connections facing up or down

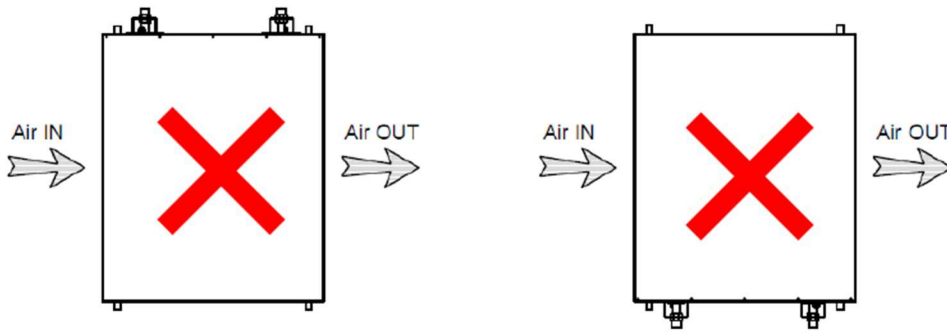

#### 4.7 Installation

Install ComfoPost near the controlled mechanical ventilation unit, on the supply pipe, before the ComfoWell.

After having unpacked the ComfoPost, fix the flange plate on the site that you intend to connect to the flow pipe coming from the ventilation unit, using the appropriate fixing guides.

Connect the ComfoPost to the ComfoWell, using the fixation rails and finally the connection plate with the ComfoTube.

Firmly fix the ComfoPost to the ceiling or the wall with a slight inclination towards the condensate drain hole.



ALWAYS connect the condensate drain downwards.

Create a dry siphon near the ComfoPost before connecting to other drains.



The condensate drain network must always be open and adequately protect from freezing.

Connect the insulated connection pipes between the ventilation unit and the ComfoPost (ComfoPipe Compact or ComfoPipe Plus).

Connect the condensate drain, making sure that the water is conveyed into the drain system correctly and without losses.

Connect the water supply pipes, carry out a leak test before proceeding with filling system, which must be done with water treated according to regulations. Insulate pipes and fittings.

Connect the air delivery pipes with a suitable thickness of insulation or use insulated pipes.



If the system is installed in a non-air-conditioned environment, even though the ComfoPost is insulated, it is advisable to add a further layer of anti-condensation insulation on the coil, the ComfoWell, the connection plates and the first meters of piping.

#### 5. Maintenance

##### For the purposes of correct operation of the system and maintenance of the guarantee:

It is essential to carry out regular maintenance of the ventilation unit. The filters must be checked every 3 months and replaced with original Zehnder filters every 6 months maximum.

Annual maintenance must be carried out by an authorized Zehnder Technical Assistance Centre, which will draw up an intervention report.

At the beginning of the summer season, the Zehnder authorized Technical Assistance Center must carry out an inspection during which it will change the unit filters, check the slope and patency of the condensate drain, and clean the finned pack of the ComfoPost coil.

The finned pack is cleaned with suitable products, similar to those used to clean and sanitize the finned packs of direct expansion systems.

This intervention may coincide with the annual maintenance.

The ventilation unit **MUST** only work with original filters correctly positioned. This prevents the exchanger and the coil finned pack from getting dirty, allowing the heating and cooling capacity to be maintained over time.

In the absence of documented proof of maintenance by a Technical Assistance Centre, the guarantee will not be recognized for damages attributable to lack of maintenance or negligence on the part of the user.

If you notice drips from the ComfoPost wrapper or spots on the outside of the wrapper:

- Check the patency of the condensate drain. A build-up of condensate inside the battery can cause it to come out of the collection tray
- Check the installation slope of the coil towards the condensate drain
- Check the continuity of the additional external insulation if present. If not present, add it

