



■ Decorative radiators ■ Comfortable indoor ventilation ■ Heating and cooling ceiling ■ Clean air solutions

Installer Manual

ComfoClima 24

ComfoClima 36



Get more
information



To configure and operate the ComfoClime the user must install the ComfoClime Control app by downloading it from Google Play or Apple Store.

Table of Contents

Preface.....	3
1 Introduction.....	4
1.1 CE and UKCA declaration and warranty	4
1.1.1 Identification plate	4
1.1.2 Warranty	5
1.1.3 Liability.....	5
1.2 Safety	5
1.2.1 Safety measures.....	6
2 For the Installer	7
2.1 ComfoClime configuration and dimensions	7
2.2 Technical specifications.....	8
2.3 Installation conditions	9
2.4 Installation of the ComfoClime	10
2.4.1 Transport and unpacking.....	10
2.4.2 Checking the delivery	10
2.5 Configuration of the unit	12
2.6 Installation procedure	12
2.6.1 Floor mounting	12
2.6.2 Installation of air ducts	18
2.7 Wiring diagram ComfoClime.....	19
2.8 Commissioning the ComfoClime	20
2.9 Operation.....	20
2.10 Maintenance - Service	20
2.11 Troubleshooting	21
3 Error and alarm messages.....	22

All rights reserved.

This manual has been compiled with the utmost care. The publisher cannot be held liable for any damage caused as a result of missing or incorrect information in this manual.



IMPORTANT!

Carefully read this manual before use.

This manual provides all the information required for a safe and optimal installation and maintenance of the ComfoClime 24 or ComfoClime 36. It is also intended as a reference for servicing, so that this can be carried out in a responsible manner. The unit is subject to continuous development and improvement. As a result, the ComfoClime 24 or ComfoClime 36 may slightly differ from the descriptions.



NOTE : this manual has been compiled with the utmost care. However, no rights can be derived from it. In addition, we at all times reserve the right to change the contents of this manual, without prior notice.

The following pictograms are used in this document:

Symbol	Meaning
	Consult the manual before using/operate the equipment.
	Point of attention / important informations.
	Risk of compromised performance or damage to the ventilation system / risk of personal injury.
	Caution electrical hazard!

All the manuals are downloadable scanning this QR-code.
You'll be redirected to the download page where you can select among a wide range of languages.



All the manuals can be downloaded also at this link:

<https://www.product-registration.zehnder-systems.com/document/comfoclime>





1 Introduction

The ComfoClima is a balanced ventilation system with passive energy recovery combined with a state of the art reversible heat pump to provide active climatization in order to create healthy, balanced, energy-efficient ventilation in houses.

1.1 CE and UKCA declaration and warranty

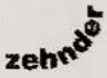
1.1.1 Identification plate

The ComfoClima has a CE and UKCA marking on the identification plate. The identification plate can be found on the front of the ComfoClima.

Zehnder Group - production site: InnoVa Srl, via primo maggio n°8 - 38089 Storo (TN) Italia					
 Made in Italy    N000005A	Type:		ComfoClima 36		COD:10018996
	Voltage	230 V ~	Frequency	50 Hz	Matr. (S/N): IN21116071
	Power input	1100 W	Current cons	4,87 A	Max Pressure PS 3.8 MPa
	GAS R32		0.65 kg		GWP-AR4 = 675

CAUTION!



It is strictly prohibited to remove the identification plate and/or replace it with other plates. Should the plate be damaged, detached or removed for accidental reasons, the customer must inform the supplier.

Please write down the ComfoAir Q and ComfoClima serial numbers here:

1.1.2 Warranty

The ComfoClima is covered by a manufacturer's warranty for a period of 24 months after fitting, and up to a maximum of 30 months after the date of manufacture. Warranty claims may only be submitted for material faults and/or construction faults arising during the warranty period. In the case of a warranty claim, the ComfoClima must not be dismantled without written permission from the manufacturer. Spare parts are only covered by warranty, if they were supplied by the manufacturer and have been installed by an approved installer.

The warranty becomes invalid if:

- The warranty period has expired;
- The unit is used without the filters properly installed in the ComfoAir Q;
- There are parts that have not been supplied by the manufacturer;
- Non-authorized changes or modifications have been made to the unit.

CAUTION!



The supplier shall not be held liable for any damage, to things or people, caused by accidents due to a failure to comply with the instructions provided in this manual and in the following chapters.

1.1.3 Liability

The ComfoClima has been designed and manufactured for use in "balanced ventilation systems". Any other use is deemed as an unintended use and can lead to damage to the ComfoClima or personal injury, for which the manufacturer cannot be held liable.

The manufacturer is not liable for any damage originating from:

- Non-compliance with the safety, operating and maintenance instructions in this manual.
- The use of components not supplied or recommended by the manufacturer.
Responsibility for the use of such components lies entirely with the installer.
- Normal wear and tear.

















1.2 Safety



Always comply with the safety regulations, warnings, comments and instructions given in this document. Failure to comply with the safety regulations, instructions, warnings and comments may lead to personal injury or damage to the unit.

- When using the Zehnder ComfoClima, all parts of the supply air system must be properly insulated in order to prevent condensation in cooling season (risk of dew point reach) or to avoid thermal losses in the heating season. The ComfoFresh air distribution system with Thermal Shield®  is suitable for this purpose.
- The air distribution system and the diffusers should be designed for a nominal air volume of at least 200m³/h for the ComfoClima 24 and 315m³/h for the ComfoClima 36.

1.2.1 Safety measures

	Always observe the local building, safety and installation guidelines of the municipality, utility companies or other authorities.
	Lift or move the unit according to the local safety regulations. The ComfoClime weighs around 60kg.
	The installation of the unit hanging on the wall is not permitted.
	Always connect air ducts with a minimum length of 900 mm to the unit before connecting the power supply to prevent contact with the internal components.
	After installation, all parts that could lead to personal injury are safely out of reach behind the casing.
	It is not permitted to modify the unit or any of the specifications contained in this document. This may result in personal injury or reduced ventilation system performance.
	Installation, commissioning and maintenance must be carried out by a certified person or company, unless stated otherwise. If this work is carried out by unauthorised persons, it may result in personal injury or reduced performance of the ventilation system.
	Always disconnect the power supply of the unit before you start working on it. The unit can cause personal injury when it is opened during operation. Make sure the unit cannot be switched back on by accident.
	Always take ESD-inhibiting measures when dealing with electronics, such as wearing an antistatic wristband. The electronics can be damaged by static charges.
	In case of failure of the heat pump circuit please do not intervene, but please call the Zehnder Service.
	The unit contains R32 refrigerant gas. This is a low-flammable, non-toxic refrigerant. Handle the unit with the utmost care during installation or maintenance activities to prevent refrigerant from leaking. Anyone involved in maintenance, repair or recycling of the product should wear gloves and eye protection all the time.
	Operations over the refrigeration circuit is not allowed. In case of failure or leakages please call the Zehnder Service for support.
	If refrigerant leaks due to a defect or damage, then: <ul style="list-style-type: none">• Open windows and doors in the room in which the unit is located for at least one hour. The unit contains 0.65kg (at room temperature approx. 0,6 m ³) of R32 refrigerant gas.
	The refrigerant is far heavier than air and it would concentrate on the floor and in case of leakage never try to contain the escaped gas and do not breath it in. In the event of contact with skin or eyes, rinse for at least 20 minutes with lukewarm water and contact your doctor.
	Product end of life: when disposing of the unit, contact your local authority to enquiry which are the possibilities for recycling or processing. The unit contains R32 refrigerant gas. It is mandatory that the refrigerant is disposed of in an environmental friendly manner: if not the contribution to greenhouse gas emissions of the volume of gas in this unit equals to 438 kg of CO ₂ .
	Flammable gas risk hazard!
	Unit under pressure risk hazard!

2 For the Installer

2.1 ComfoClima configuration and dimensions

The standard ComfoClima configuration consists of:

- 1 ComfoClima unit;
- 1 cabled power supply plug;
- 4 rubber ring gaskets;
- 1 condensation drain cap;
- 2 EPP standoffs;
- 1 white plastic front cover;
- 1 quick user guide;
- 1 ComfoNet cable;
- 1 kit for wall fastening (with screws);
- 1 DN32 PP bend.

CC24 - Ø 175 mm (DN 160)

CC36 - Ø 215 mm (DN 200)

CC24 - Ø 175 mm (DN 160)

CC36 - Ø 215 mm (DN 200)

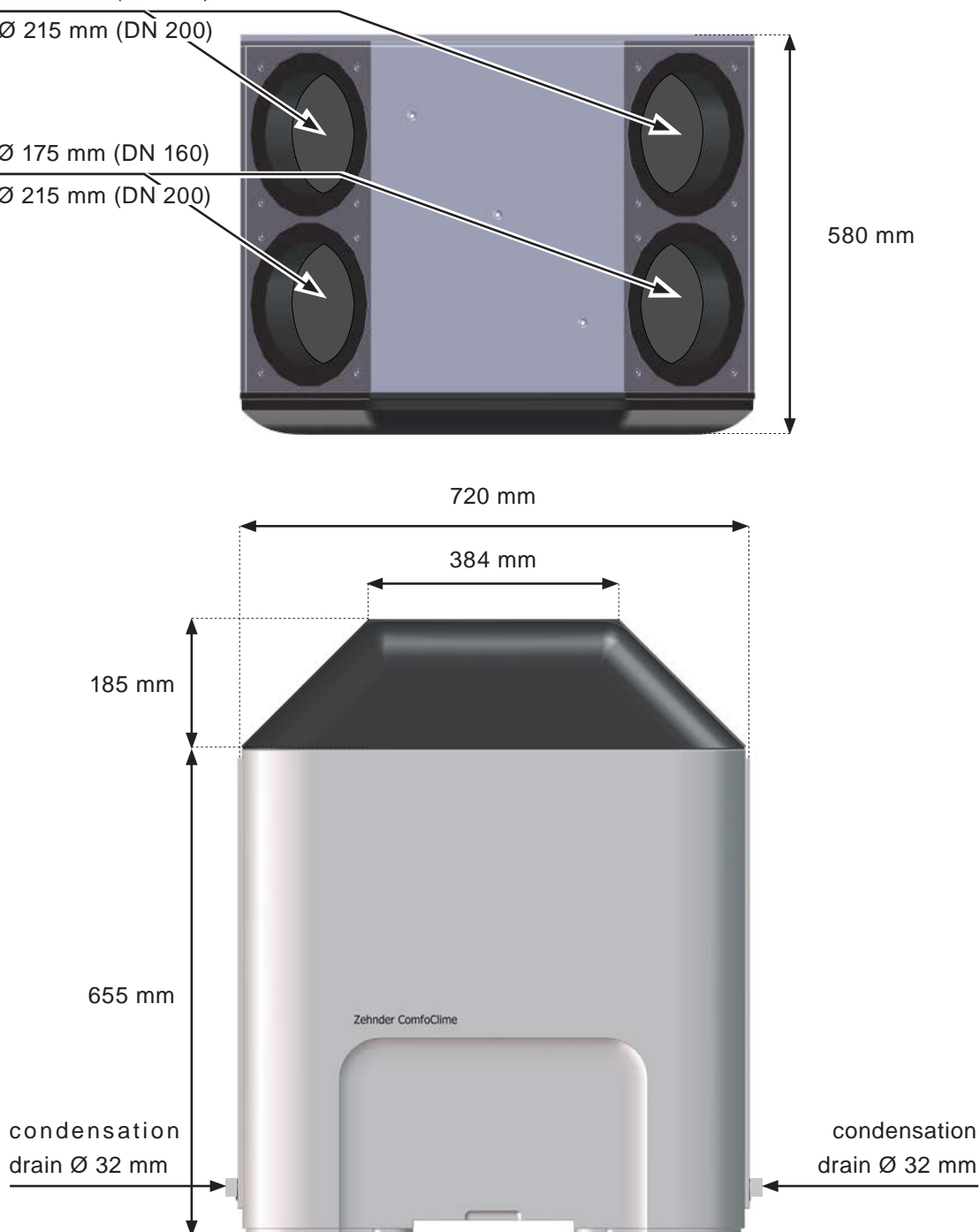

2.2 Technical specifications

	ComfoClima	
	ComfoClima 24	ComfoClima 36
Performance		
Minimum airflow	200 m ³ /h	315 m ³ /h
Maximum airflow	400 m ³ /h	600 m ³ /h
Electrical connection details		
Maximum electrical absorption	1100 W	1100 W
Power supply	230 V ± 10%, single phase, 50 Hz	230 V ± 10%, single phase, 50 Hz
Current draw	4.87 A	4.87 A
Fuse	16A, cat. C	16A, cat. C
Mechanical connection details		
Dimensions of air ducts (Ø)	175 mm (ComfoPipe Compact DN160)	215 mm (ComfoPipe Compact DN200)
Diameter of condensation drain (Ø)	32 mm	32 mm
Material specifications		
Casing	Coated metal sheet	Coated metal sheet
Internal structure	Insulated metal sheet	Insulated metal sheet
General		
Temperature range during transport and storage	+5°C to +50°C	+5°C to +50°C
Temperature range intake air	-15°C to +50°C	-15°C to +50°C
Temperature range of installation area	>10°C	>10°C
Relative humidity of installation area	<90% (non-condensing)	<90% (non-condensing)
Front panel	White plastic	White plastic
Refrigerant gas (weight)	R32 (650g)	R32 (650g)
GWP-AR4	675	675
Maximum Pressure	38 bar	38 bar
Weight	60 kg	60 kg

2.3 Installation conditions



In case of retrofitting installation, it's recommended that the ComfoAir Q has the latest firmware with a minimum of release 1.10 (see ComfoAir Q manual).

In order to determine whether the ComfoClime can be installed in a certain area, the following aspects must be taken into account:

- The unit must be installed in a frost-free space;
- The ventilation unit must be mounted only on flat, stable floor.



CAUTION!

Fitting to a ventilation unit mounted onto the wall is NOT permitted for safety reasons.

- The roof vents should be made airtight and dampproof;
- All supply, outdoor and exhaust ducts should be dampproofed. This prevents condensation forming on the inner or outer duct surface and improves air temperature efficiency;



CAUTION!

DO NOT connect a powered extractor hood to this system.

- We recommend fitting the unit with silencers right after the unit, on both the supply and extract ducts. For more information, please contact Zehnder;
- The installation location must be chosen so that there is sufficient room around the unit for air duct connections, intake and exhaust piping and in order to carry out the installation. Keep at least 1 metre free in front of the unit and 25 cm to the side where the condensation drain is connected to the waste water;
- The free height when mounted should be at least 210 cm, in order to allow enough space for the ducts connection;
- Connect the unit to a 230 V~ 50 Hz power supply. Any other connection would damage the unit and is not permitted;
- The unit is designed for use in residential areas only. The unit is not suitable for commercial use such as in swimming pools or saunas. Installation in an industrial environment can damage the unit;
- The allowed temperature of the installation area is provided in the section “Technical specifications”;
- Zehnder recommends that the unit is not installed in spaces with higher-than-average humidity (such as laundry rooms or swimming pool environment). This prevents the formation of condensation on the external surface of the unit;
- Check whether the electrical installation can fulfil the maximum capacity of the unit. The maximum capacity is provided in the section “Technical specifications”;
- All units are suitable for a 230V ~ 50Hz single phase supply fused 16A cat. C.

2.4 Installation of the ComfoClime

2.4.1 Transport and unpacking

! **Contact your supplier immediately in case of damage or incomplete delivery and do not proceed with the installation.**

- Take the necessary precautions when transporting and unpacking the ComfoClime unit.
- Only transport it in an upright position.
- Keep it upright when unpacking it.
- Make sure the packing material is disposed of in an environmentally friendly manner.

2.4.2 Checking the delivery

- The ComfoClime unit (with its white front cover);



! **Check the identification plate to ensure that you have received the correct unit type**

- One plug for the unused condensation drain;

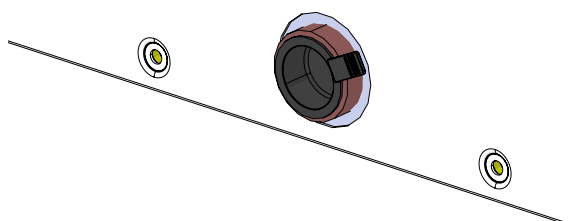

■ 2 EPP standoffs;



■ 4 rubber gaskets;



■ Wall bracket;



■ DN32 PP bend;



■ Wiring group.

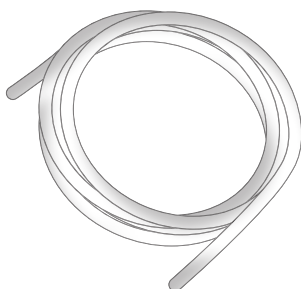

2.5 Configuration of the unit

Legend

ACRONYM	MEANING
R	Right layout
L	Left layout
ODA	Outdoor air intake
SUP	Indoor supply air
ETA	Indoor air extraction
EHA	Outdoor air exhaust

Consider the following schemes to connect the ducts:

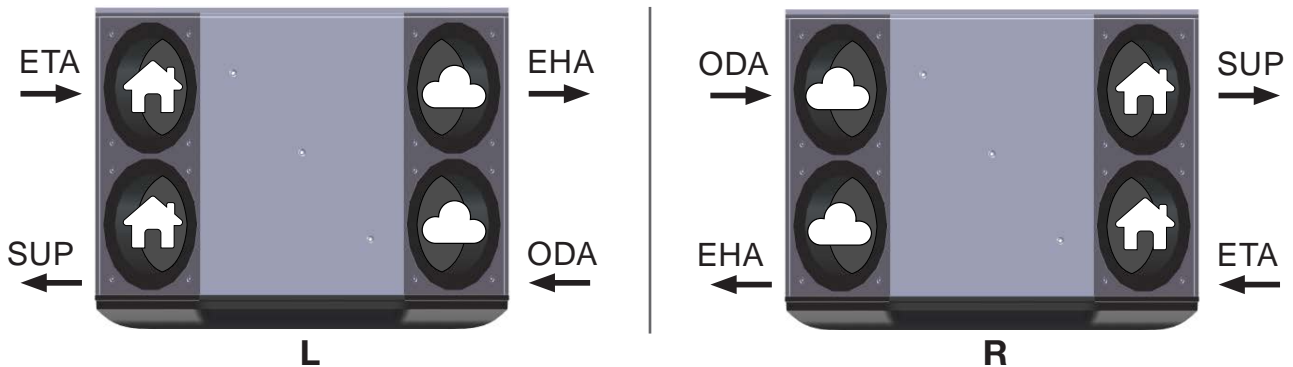

2.6 Installation procedure

During the installation, please take into consideration electromagnetic interferences.

- Ensure that there is a barrier (e.g. separate duct or compartment) or minimum distance of 150 mm between the interfering power cables (e.g. 230 V) and cables sensitive to interference (e.g. testing, low voltage, interface, LAN, digital or analogue signal).
- Make sure interfering and sensitive cables cross each others perpendicularly.
- Ensure that the cables used for the controls meet the requirements specified in the section “Technical specifications”.

These measures will limit the EMC disruptions as much as possible and ensure the best communication.

2.6.1 Floor mounting

CAUTION!



Do not connect the ComfoAir Q nor the ComfoClima to the power supply until the end of the complete installation and the mutual connection of the units is done. The unit must not be mounted/hung onto the wall.



For the anti-tilt plaque please use proper fastening screws accordingly to the type of wall.



The installation position must be horizontal.



Before proceeding with the ComfoClima installation, write the serial number of the ComfoAir Q, located below the grey upper lid, in the designated space of the ComfoClima installer manual. This serial would be useful in case of future remote access to the unit . Write down also the serial number of the ComfoClima for an easy future necessity of it.

The ComfoClima must be placed on top of the ComfoAir Q according to the following steps:

Step	Action
1	Make sure that the ComfoAir Q is properly placed in its final position (see the ComfoAir Q installation manual);
2	Put the two EPP standoffs on the top part of ComfoAir Q as shown in the picture with the metallic plates on the front;
3	Place the four rubber gaskets over the spigot openings verifying the full insertion of them. Check that the sealings are creating an effective seal between the spigot and the adapter plates;
4	Once carefully unpacked, remove the two parts of the front pulling out the upper black top A and unscrewing the four screws (two on the top and two on the bottom) of the white cover B;

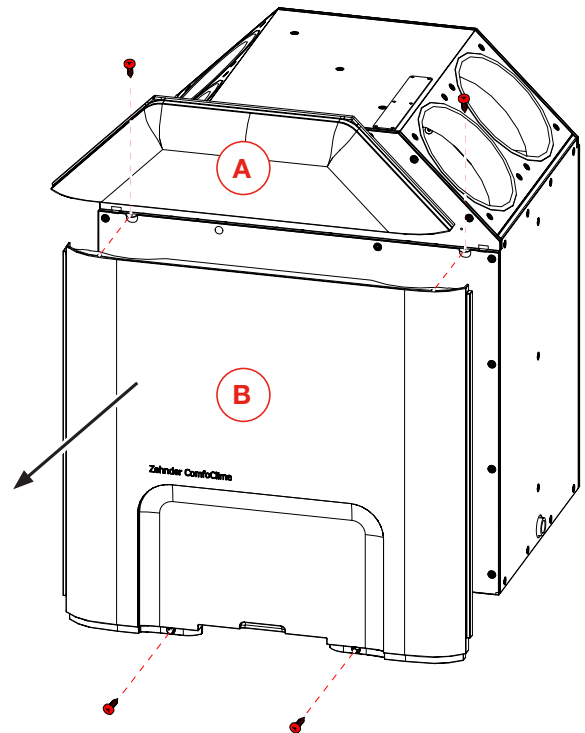
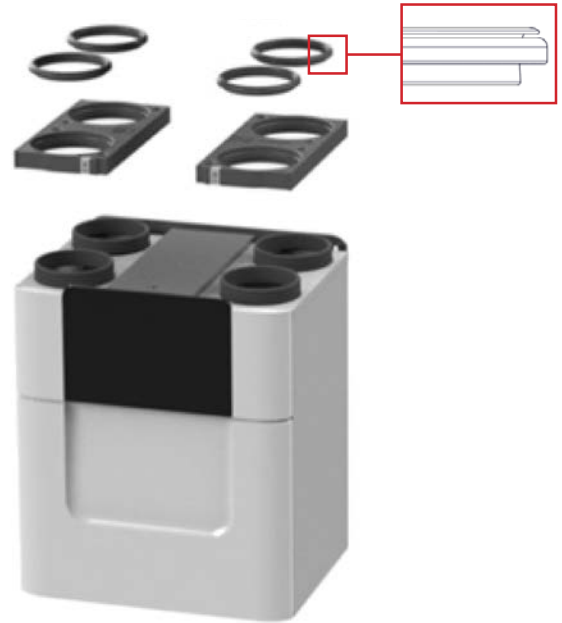

Step	Action
------	--------

Unpack carefully the ComfoClime and place carefully the ComfoClime over the ComfoAir Q respecting all the safety rules taking as reference the four pins on its bottom which have to fit in with the corresponding recesses in the EPP standoffs;



WARNING!

Never lift the unit alone. It is heavy and must be mounted with accuracy and carefully, being sure the gaskets do not dislodge while installing.

5

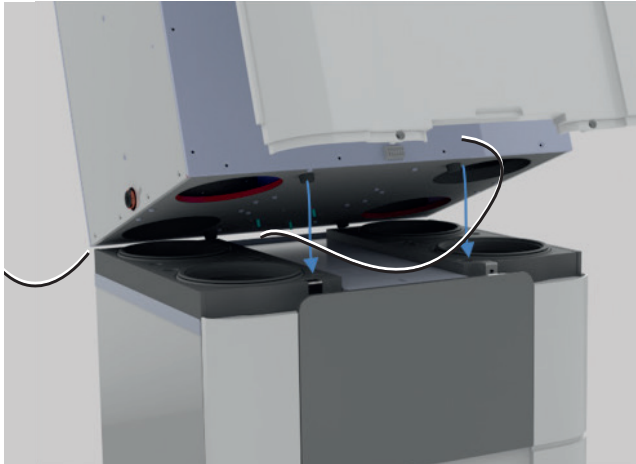

NOTE: during the placement of the ComfoClime on top of the ComfoAir Q, remember to arrange the power supply cord so that it will exit from the back of the unit.

Connect the free end of the provided ComfoNet cable to the ComfoAir Q connector paying attention to make the cable going to the back of the unit and then coming back to the front staying below the grey skid/lid of the ComfoAir Q as shown:

- a. **CAN_L:** white
- b. **CAN_H:** yellow
- c. **GND:** black

6

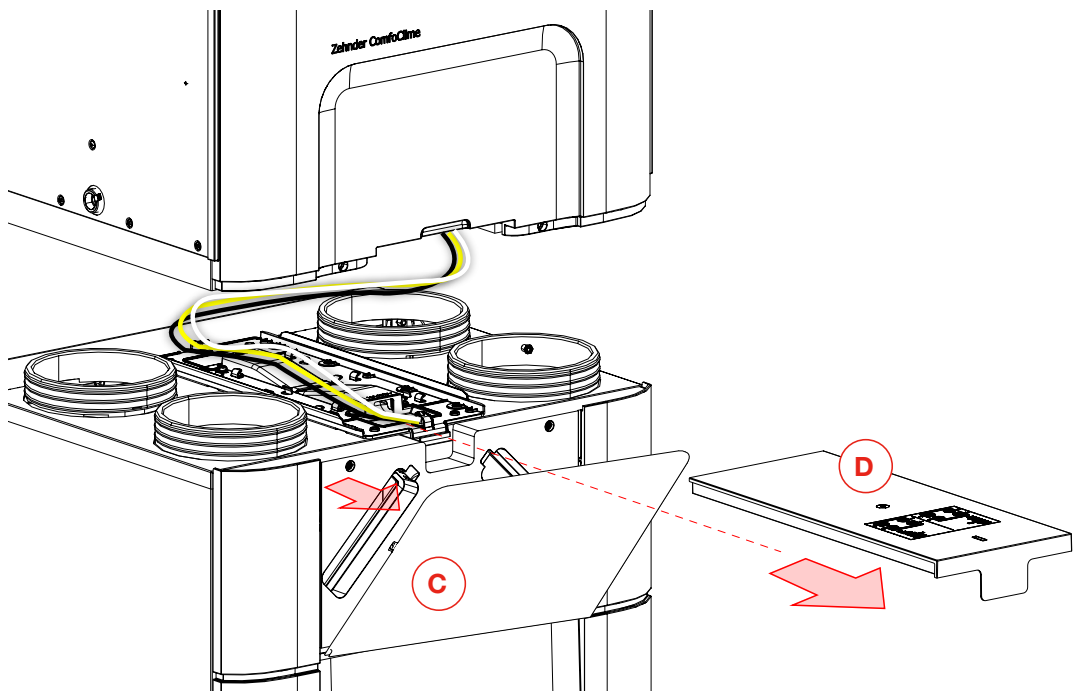

To get access to the front ComfoAir Q connector, open the black panel of the ComfoAir Q rotating it downwards and pull out the grey lid D;

Verify that the blue central rotary switch is in the proper position:

- **0 for ComfoClima 36**
- **1 for ComfoClima 24**
- **2 for ComfoClima Q**

if necessary ensure it is in the correct position using a flat screw driver;

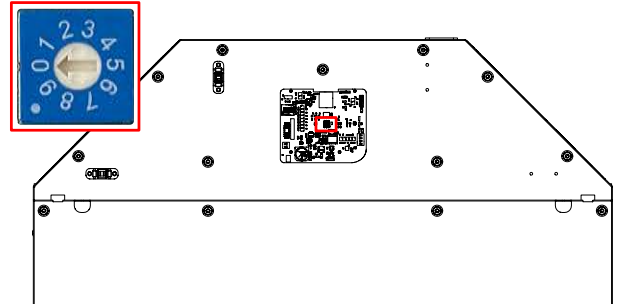

The ComfoClima can be reset in two different ways.

In both cases it is not necessary to unplug the ComfoClima.

The first, the "soft" reset, is done by pressing the upper micro-button named RESET once.

The second, the "factory" reset, is done through a sequence of three steps:

1. press the RESET button;
2. while the RESET is pressed, press also the RESTORE button;
3. release the first RESET button and holding the RESTORE pressed down wait for around 10 sec until the green LED on the right of the rotary switch starts blinking.

7

Now it is possible to release the RESTORE button.

The soft reset is equivalent to turning off the unit or unplug it.

The factory reset brings back the unit to the factory default settings meaning that every customisation will be lost, including the provisioning procedure. The ComfoClima must be provisioned from scratch following the initial procedure illustrated at the chapter 1.1 of the User manual.

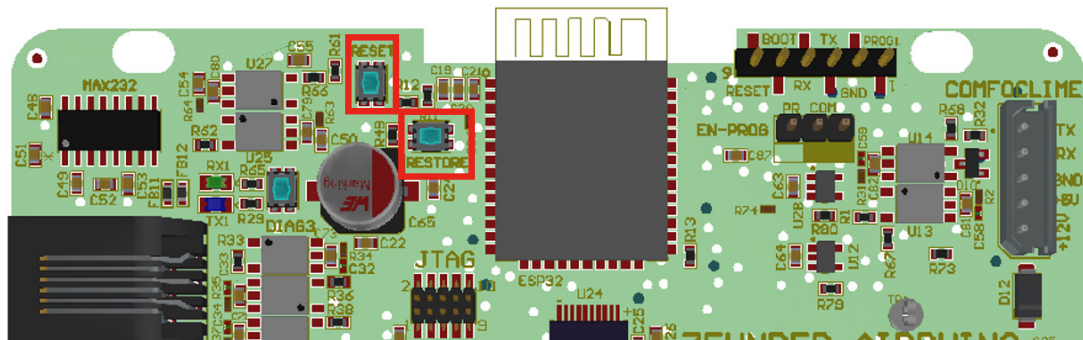

See **Step 9** to put back in place the black top cover, carefully, fastening it gently to the four hooks.

Step	Action
8	<p>Fix the anti tilt plate (on top of the ComfoClima) firmly to the ComfoClima using the screws included in the packaging.</p> <p>Afterwards fix the ComfoClima to the wall using a proper fastening system suitable for the type of wall.</p>
9	<p>Mount the plastic front cover A onto the unit. Check that the top of the plastic design front is properly matching the recesses and that it goes smoothly above the CAQ front plastic cover. Then fix the ComfoClima plastic front A with the two provided screw on top and the two on the bottom; mount the black top front cover B pushing gently the four pins into the housing.</p>

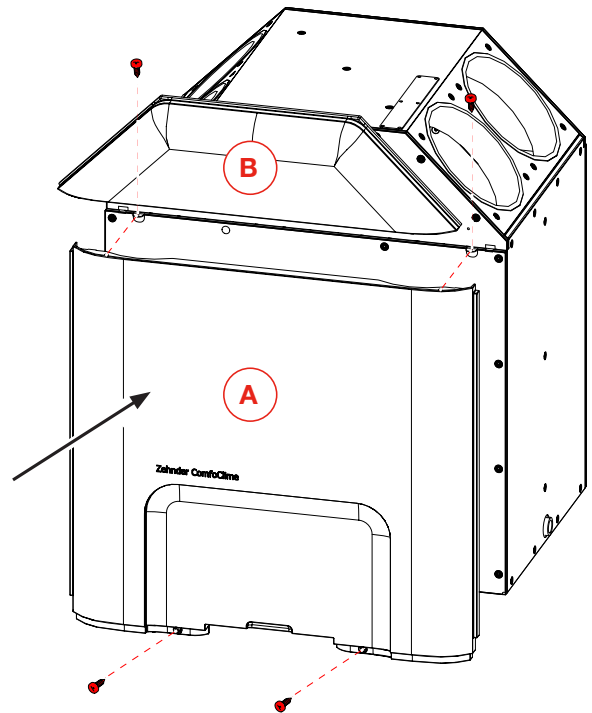
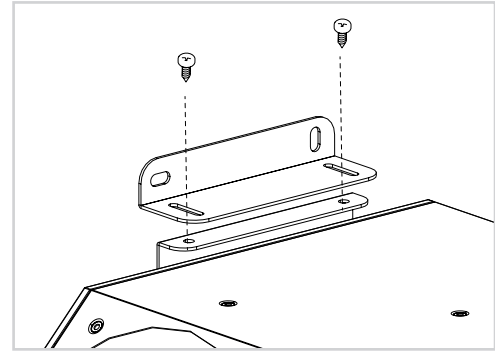
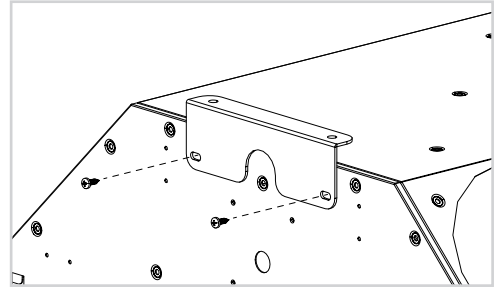

Step	Action
------	--------

Connect the preferred drain ending, placed on the lateral side to the water drain system and plug the other up with the provided cap.

NOTE: do not install a dry siphon: the overpressure in the unit could open the dry siphon guard and cause an air leakage.

Install only external wet siphon with a 100mm guard according to the local regulations. The siphon can have an open funnel.



10



*

Depending to the installation setting, the drainage system will be different as shown in the following pictures:

Installation with CAQ HRV (standard exchanger)

Installation with CAQ ERV (enthalpy exchanger)

11

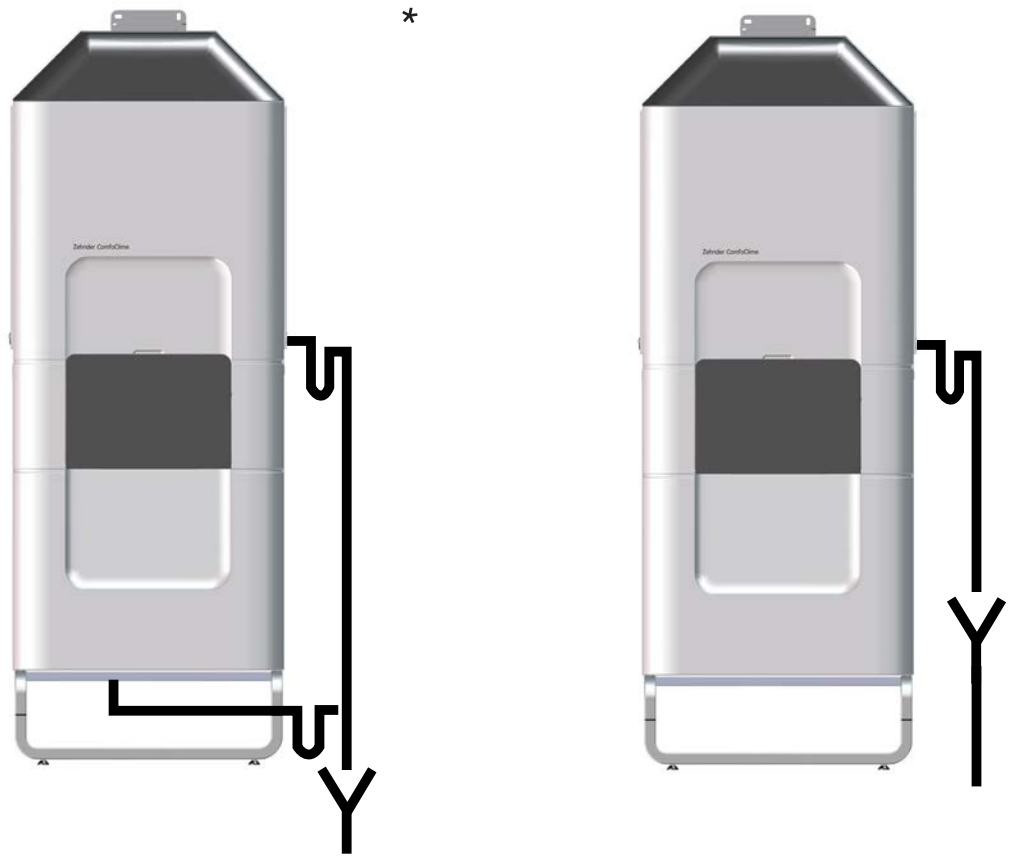

* an open funnel might be required according to local regulations.

2.6.2 Installation of air ducts

CAUTION!



Do not connect the ComfoAir Q nor the ComfoClima to the power supply until the end of the installation and the duct connection of the units are fitted. The unit must not be mounted/hung onto the wall.



Always comply with the safety regulations, warnings, comments and instructions given in this document and according to regulations within the local country. Failure to comply with the safety regulations, instructions, warnings and comments may lead to personal injury or damage to the unit.

Proceed with the installation of the air ducts according to the following steps:

Step	Action
1	Connect the supply/extract ductwork to the four intakes on top of the ComfoClima;
2	Then proceed with the air distribution. In brand new installations it is mandatory to provide an insulated ductwork, installing the pre-insulated Zehnder ComfoFresh Thermal Shield system components. The pre-insulated ductwork is strongly suggested in existing installation as well (retro fitting)



2.7 Wiring diagram ComfoClima

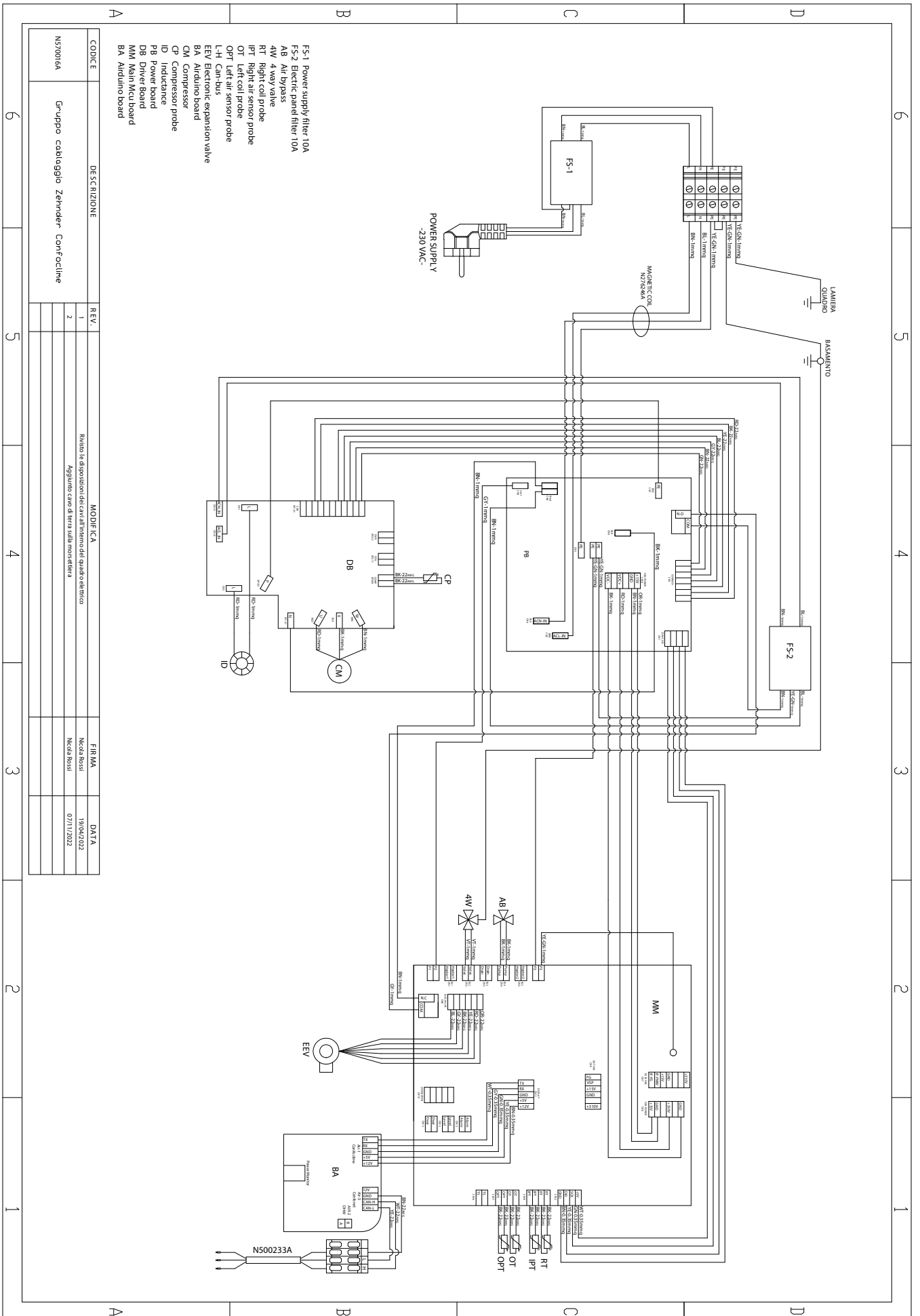

2.8 Commissioning the ComfoClime

After installation, the ComfoClime system must be commissioned.



In case of retrofitting installation, it's recommended that the ComfoAir Q has the latest firmware with a minimum of release 1.10 (see ComfoAir Q manual).

Proceed with the unit activation according to the following steps:

Step	Action
1	Connect to the ComfoAir Q and the ComfoClime to the power supply;
2	On the upper front part of the ComfoClime one green LED should turn on to indicate the correct installation and functioning (see Par. 2.11 Troubleshooting for details);
3	Proceed with the CAQ commissioning (see CAQ installer manual);
4	Once the CAQ commissioning is finished it is possible to begin the setup procedure of the ComfoClime, through the control device (see the ComfoClime 34/36 User manual for provisioning and configuration instructions).

2.9 Operation

The ComfoClime works by supplying the air at a given temperature, in order to fulfil the comfort condition set by the user through the ComfoClime Control app.

The supply air temperature is automatically determined by the ComfoClime accordingly to the outdoor conditions and the chosen comfort profile.

In cooling mode the ComfoClime doesn't control the humidity in an active way but accordingly to the whole system capability. The ComfoAir Q, only when fitted with the enthalpy cube, balances the humidity between the outdoor air and the exhaust air; afterwards the ComfoClime heat pump, based on the operating mode (heating or cooling mode), will reduce the absolute humidity.

For example:

- In heating mode the ComfoClime raises the air temperature reducing automatically the relative humidity without condensation;
- In cooling mode the ComfoClime cools down the air reducing the relative humidity through condensation.

2.10 Maintenance - Service

The ComfoClime doesn't require any ordinary maintenance activity.

A general accurate and deep cleaning is requested every 2 years at least. Please contact Zehnder Service for it or refer to the Service Manual.



WARNING!

Before every operation over the unit please disconnect the electric power.



CAUTION!

For others maintenance operations please refer to the Service manual. Only Zehnder authorised personnel should open on the unit.

2.11 Troubleshooting

This paragraph concerns issues related to the main unit.

CAUTION!



Never open the unit nor touch the internal components. Only authorized personnel can get access to the internal components.



CAUTION!



In case of malfunctioning such as weird noise, bad smell, water leakages, unplug the power supply and call a Zehnder Authorised Representative.

On the upper part of the front cover, behind the black transparent panel, a couple of LEDs indicating the actual working mode of the unit are visible.

The possible colours are:

Led colours	Meaning
	<ul style="list-style-type: none">■ Left (multicolour LED):<ul style="list-style-type: none">■ RED permanent: heating mode.■ BLU permanent: cooling mode.■ GREEN blinking: an error occurred.□ OFF: the device is off.(see notifications on the app)
	<ul style="list-style-type: none">■ Right (GREEN):<ul style="list-style-type: none">■ Fast blinking: ComfoNet BUS off.■ Slow blinking: ComfoNet is connecting.■ Permanent ON: ComfoNet properly connected and working.

3 Error and alarm messages

In this page it is possible to read the messages coming from the unit: errors, alarms, alert, advice. Each of them is related to the interested device.

The following table lists the error codes that could appear in this page:

Code	Component	Description	Solution
1	Airduino	The rotary encoder is set to a forbidden value.	Call Zehnder Service
21	CAQ	ComfoAirQ communication error. CAQ not visible on ComfoNet.	Check that the green LED on CAQ and Clime is fixed lit. Try rebooting all the system. Check that all the firmwares are up to date. If not fixed call Zehnder Service
22	CAQ	Failed to synchronize CAQ comfort temperature profile	Same as 21
23	CAQ	Failed to synchronize CAQ comfort temperature value	Same as 21
24	CAQ	Failed to set CAQ comfort temperature mode	Same as 21
25	CAQ	Failed to synchronize CAQ cooling limit	Same as 21
26	CAQ	Failed to synchronize CAQ heating limit	Same as 21
27	CAQ	Failed to get ComfoAirQ orientation	Same as 21
28	CAQ	ComfoAirQ not commissioned	Do the commissioning procedure on the CAQ
31	HP board	Heatpump board communication error	Tryt rebooting the system or, if not sorted out, Call Zehnder Service
32	HP board	Clime supply temperature probe failed	Call Zehnder Service
33	HP board	Clime incoil temperature probe failed	Call Zehnder Service
34	HP board	Clime mixed air temperature probe failed	In ComfoClime36 this could be due to error 38
35	HP board	Clime outcoil temperature probe failed	Call Zehnder Service
36	HP board	Clime fan error	Call Zehnder Service
37	HP board	Clime Compressor driver communication error	Call Zehnder Service
38	HP board	Clime HP data timeout	Call Zehnder Service
39 - 47	HP board	Reserved for future use	
48	Inverter	Inverter phase current limit error	Call Zehnder Service
49	Inverter	Inverter current limit error	Call Zehnder Service
50	Inverter	Inverter power limit error	Call Zehnder Service
51	Inverter	gas discharge temperature probe failed	Call Zehnder Service
52	Inverter	compressor case temperature sensor error	Call Zehnder Service
53	Inverter	compressor driver PFC error	Call Zehnder Service
54-63	Inverter	Reserved for future use	-
81	Power Monitor*	Power monitor communication error	Call Zehnder Service

* only for ComfoClime Q

PAGE INTENTIONALLY LEFT BLANK

