

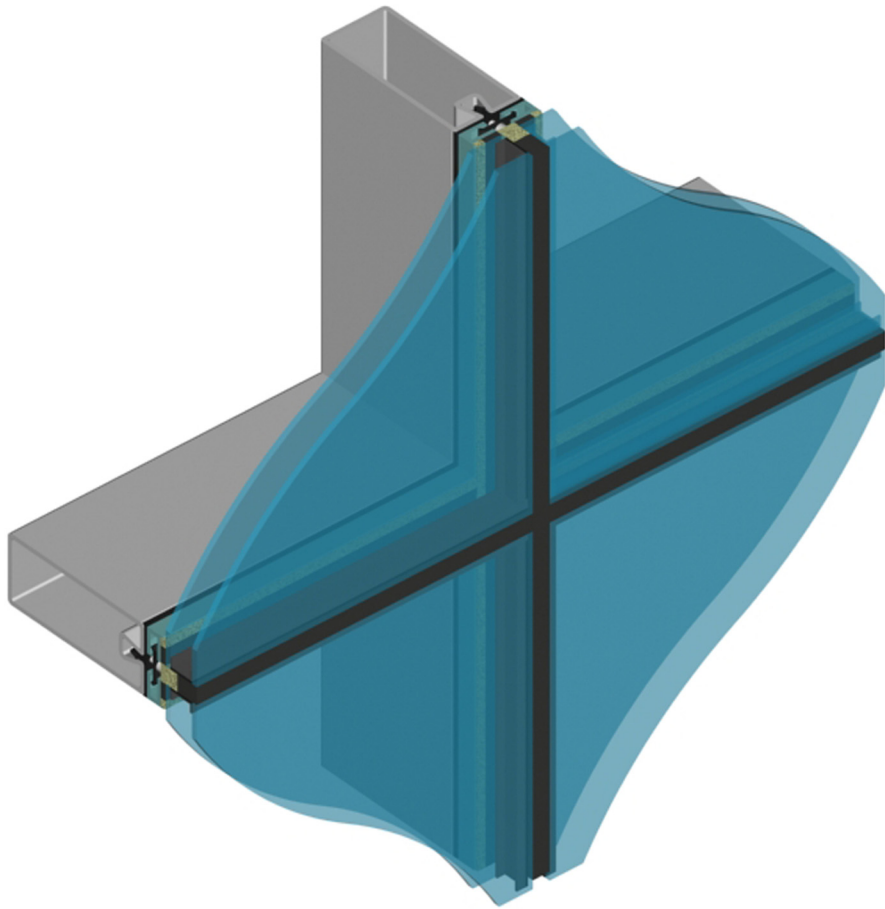

wrightstyle^{ltd}

blast resistant system datasheet



- Slimline system
- 60mm profile widths
- Structurally glazed
- Bracket construction
- Multi panel testing
- Large span capability
- 17mm edge cover
- Multiple detonation test
- Close & long range use
- Multiple glazing options
- Lorry & car bomb tested

High strength mullion

EPDM bedding gasket

Heavy duty transom bracket

High strength transom

Site applied SG clips

Factory prepared SG frame bonded to glass for 'unitised' site installation

External solar control glass

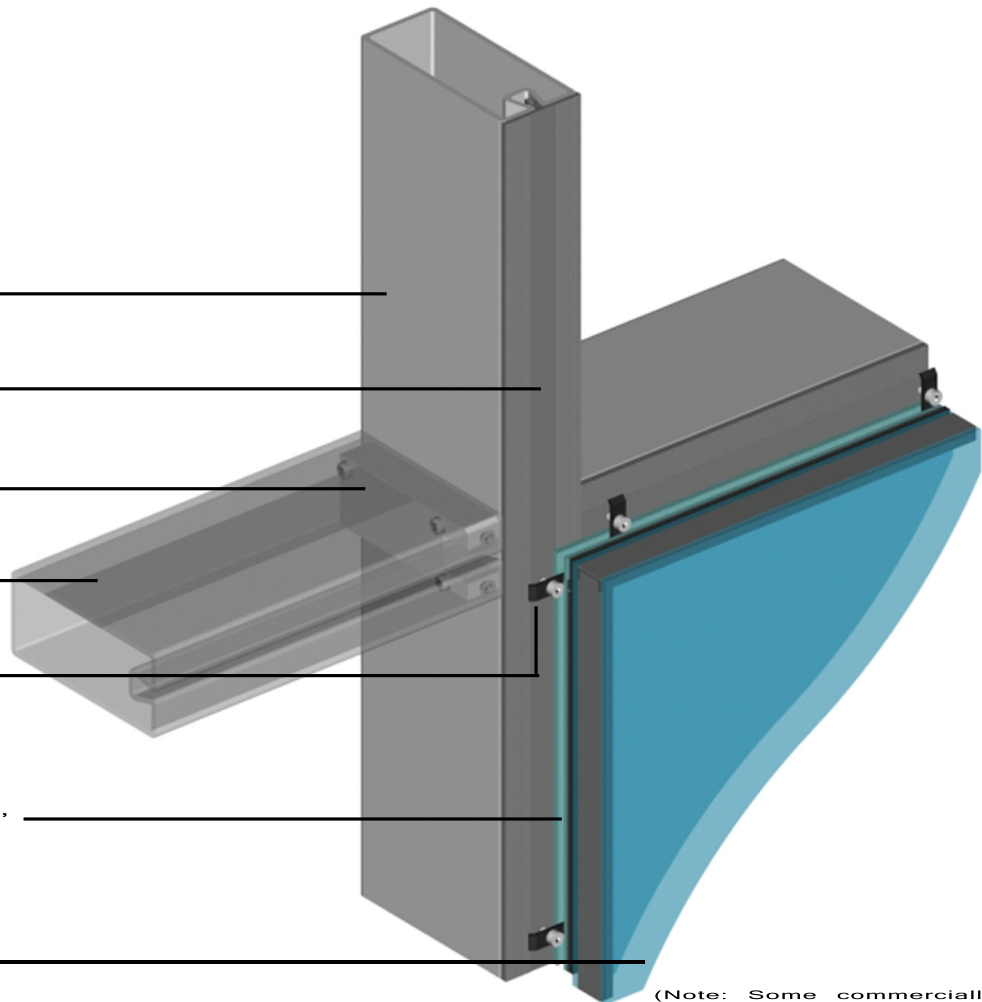

(Note: Some commercially sensitive detail omitted)

Test number 1 - Cubicle #1



Before detonation



Blast



After detonation

Test number 1 - Cubicle #2



Before detonation



Blast



After detonation

Test number 2 - Cubicle #2



Before detonation

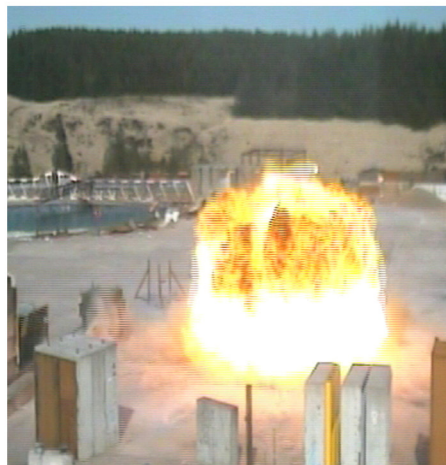

Blast



After detonation

The information below is a summary of measurements & results taken from the official report. This report remains confidential, due to information on exact charge weights and stand-off distances. In summary, test number 1 simulated a lorry bomb, and test number two simulated a car bomb at close range. An explanation of the classifications can be found on the next page. It should be noted that cubicle #2 received two blasts within a matter of hours and still resulted in a high protection classification.

Test number 1 - Cubicle #1 measurements & results

Max positive overpressure +29kPa
Max positive Impulse +305 kPam/s

Result ISO/DIS16933/HOSDB Hazard rating A - 'No Break'
Result GSA PBS-P100 GSA1 Protection level safe - Hazard level none

Test number 1 - Cubicle #2 measurements & results

Max positive overpressure +37kPa
Max positive Impulse +370 kPam/s

Result ISO/DIS16933/HOSDB Hazard rating A - 'No Break'
Result GSA PBS-P100 GSA1 Protection level safe - Hazard level none

Test number 2 - Cubicle #2 measurements & results

Max positive overpressure +133kPa
Max positive Impulse +650 kPam/s

Result ISO/DIS16933/HOSDB EVX19 / Hazard rating D - 'Very low hazard'
Result GSA PBS-P100 GSA3b Protection level high - Hazard level low

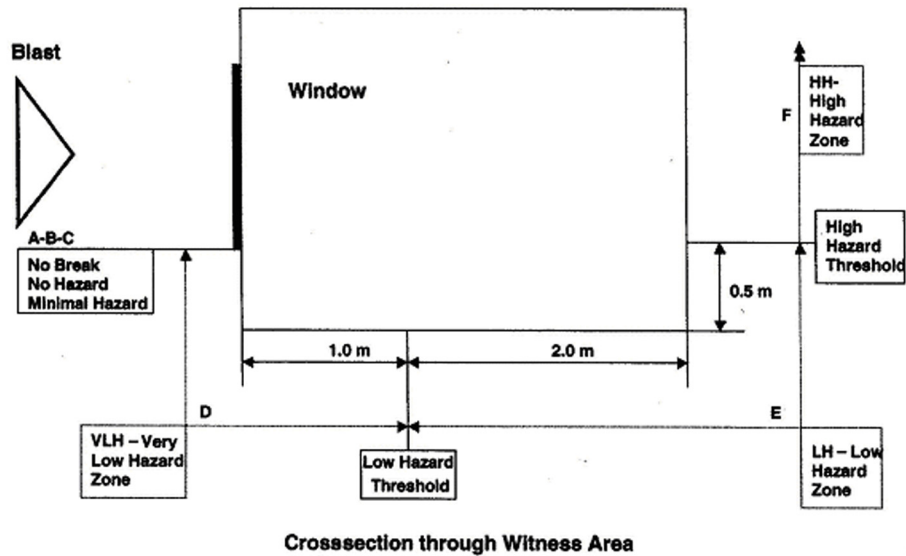

Classifications of test results can be summarised in the above diagram. This illustrates a typical installation of a glazing system with the indicated hazard zones according to US, European & UK specifications. The exact protection level required on a particular project requirement, would be determined by the nominated security consultant within a countermeasure design study.

High speed video captures - low res versions can be seen on our website at the following address: www.wrightstyle.co.uk/blasttest



high performance steel & glass systems
complete and guaranteed