

WMX 504 / 504 UL / 804 / 804 UL

CHAIN ACTUATOR

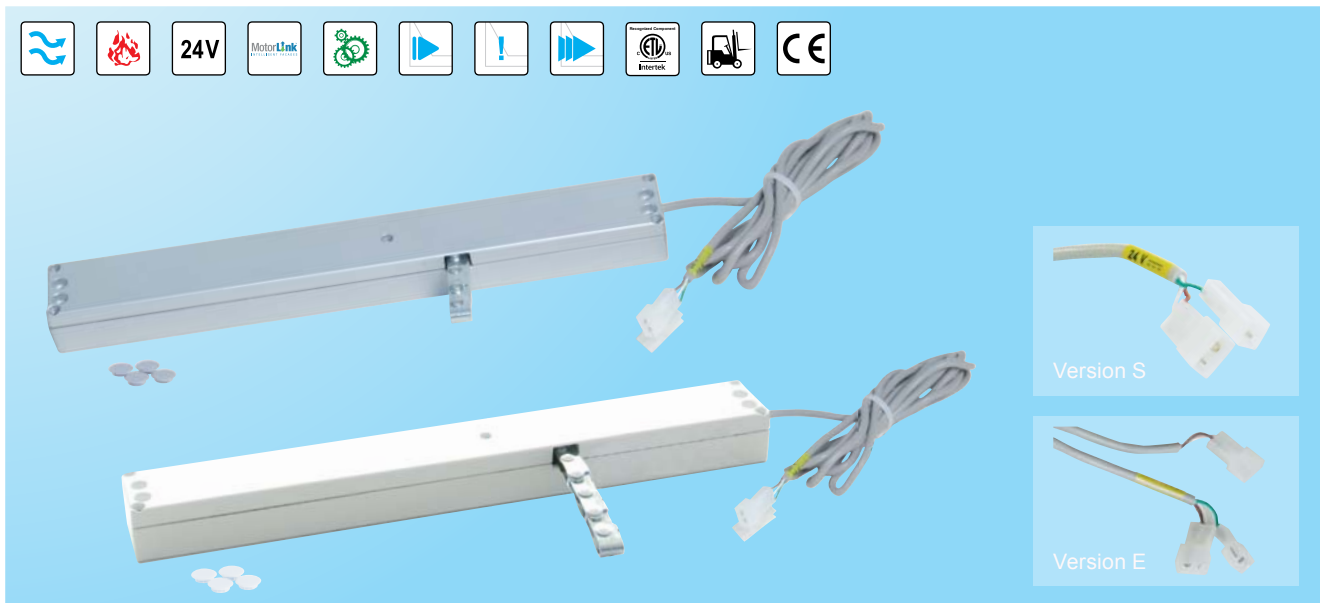

Description

- designed for surface mounting
- WMX 504 / 504 UL / 804 UL: for comfort ventilation
- WMX 804: for smoke and comfort ventilation
- to be used with all window types
- to be used together with $\pm 24V$ control units or control units with MotorLink™
- can be used together with espagnolette WMB
- external safety edge can be connected directly to the actuator (actuator version 'E')
- available with and without ETL certification:
 - Europe: order without ETL certification
 - USA / Canada: order with ETL certification (version UL)
- synchronization of up to four window actuators – no need for an external synchronization module
- genuine position feedback and three speeds when using control unit with MotorLink™
- soft close
- the electronics in this actuator can be programmed to suit specific requirements – i.e. pressure- and traction force, stroke, speed/sound level – with the WAT 100 programming box, also possible following installation
- built-in electronic load switch-off/end stop
- electronic actuator with micro controller
- the actuator has an integrated reverse function to ensure a prolonged life span of the window gaskets
- easy mounting

Actuator variants

The actuator is available in four different versions: single actuator (-1), double actuator (-2), triple actuator (-3) and quad actuator (-4).

The synchro actuators (-2, -3 and -4) are equipped with a patented synchronization function, in which the actuators communicate directly with each other, which ensures the actuators operate at exactly the same speed and position. On large windows up to four actuators can be mounted on the same window – with no need for an external synchronization module.

Pressure safety function

The risk of entrapment is reduced as the actuators are programmed to reverse if they encounter obstacles when closing. The set points determining when the actuators are to reverse are individually adjustable and can be adjusted after installation using the programming box WAT 100.

Opening speeds

One speed:
Actuators connected to ± 24 VDC control units (e.g. WUC) have one chain speed – see the following page for opening speed.

Three speeds:
Actuators connected to control units with MotorLink™ (e.g. WSC xxM) have three different speeds:

- slow speed by soundless automatic control of the windows
- faster speed by audible manual (keypads) control of the windows
- fast speed by smoke ventilation and security functions

Technical specifications	
Locking force	3000N
Permitted short pressure load when chain has run to end stop	100N
Short pressure capacity on motor	Max. 150N (e.g. at the beginning of opening: sticky gasket, ice, wind speed)
Chain opening	50 – 250mm in increments of 10mm, maximum opening depends on the window construction
Opening speed	7mm/s (programmable from 3mm/s to 9.5mm/s)
Window types	Window types and sizes must be agreed with the window supplier and WindowMaster
Window width	Min. 365mm, maximum width depends on the window construction and the number of window actuators
Window height	Min. 300 / 400mm (see installation suggestions 1 and 3), maximum height depends on the window construction and the number of window actuators
Nominal voltage	24 VDC (max. 10% ripple)
Voltage	20 - 36 VDC
Max. open-circuit voltage	Max. 36 VDC
Current consumption	WMX 504 / 504 UL: max.0,5A WMX 804 / 804 UL: max. 1,0A
Operating condition	-5°C - +74°C, max. 90% relative humidity (not condensing)
Switch-on-duration	ED 40% (max. 4min. per 10min)
Material	Lacquered zinc housing with 10mm zinc cromate passivated steel chain and a 2m 3-core 0,34mm ² cable with fast-in/fast-on connectors for connection to the extension cable WLL WMX 504 / 804: 2m grey silicone cable WMX 504 UL / 804 UL: 2m UL listed/recognized cable in grey (grey actuator) or white (white actuator)
Colour	Aluminium (RAL 9006) or white (RAL 9010), other RAL colours available at additional price
Size	332 x 29 x 42mm (W x H x D)
Weight	1.0kg
IP rating	IP20 - when surface mounted / IP32 - when concealed
Certification	Actuators with "U" in the article no. are ETL certified accordingly to UL 325 and CAN/CSA-22.2 No. 247-92 and is supplied with UL approved cables UL STYLE 2464
SHE test	WMX 504 / 504 UL / 804 UL: not SHE tested WMX 804*: tested in accordance with DIN 18232-3, section 3.6 (30 minutes at 300°C) *The construction of the actuator is identical with WMX 802, which has passed the SHE test
Life span	Tested with 10,000 opening and closing movements
Delivery includes	Actuator with 2m cable with fast in/fast out connector for WLL cable
To be ordered separately	Brackets and WLL extension cable
Note	We reserve the right to make technical changes

Brackets	Item no.
Chain bracket with tight-fitting bolt, WMX, for sash or frame	WAB 801
Chain bracket with split, for sash or frame	WAB 860
Chain bracket for wooden windows, for sash	WAB 867
Angle bracket for actuator, aluminium RAL 9006	WAB 804 0101
Angle bracket for actuator, white RAL 9010	WAB 804 1101
Z bracket for actuator WMX 504/804/526/826. Sash min. 800mm	WAB 805
Z bracket for actuator WMX 804 – for windows with offset sash min. 15mm	WAB 807

See separate product sheets for further information.

Product code composition (actuator supplied in sealed plastic packaging)

WMX 504 WMX 804	n	x	xxx	x	x	3
						Product version: 3
						Certification: 0 = CE, U = CE + UL/ETL
						Actuator hardware version: S = standard, E = with connection for pressure safety strip (E: not UL actuator)
						Chain opening: 50 – 250mm, in increments of 10mm (050 = 50mm)
Colour: G = grey, W = white						
Actuator variant: 1 = single, 2 = double, 3 = triple, 4 = quad						

Explanation of product code structure

WMX 504-2G070E 03

WMX 504 actuator, double synchronisation, grey, 70mm chain opening, with connection for pressure safety strips, with CE certification, product version 3

Product code composition (actuator supplied in sealed plastic packaging and cardboard box)

The actuator is supplied with 250mm chain opening and actuator hardware version standard 'S'.

WMX 804	n	x	01	03		
					Product version: 03	
					Market variant: 01 = for Europe	
					Colour: G = grey, W = white	
					Actuator variant: 1 = single, 2 = double	

Explanation of product code structure

WMX 804-2G 0103

WMX 804 actuator, double synchronisation, grey, for Europe, product version 3.

Installation suggestion 1

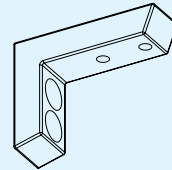
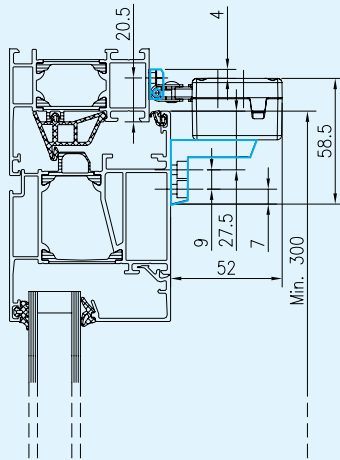

WAB 804 0101

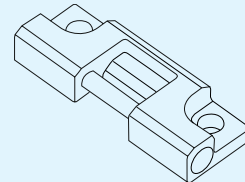

WAB 801

Installation suggestion 2

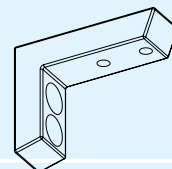
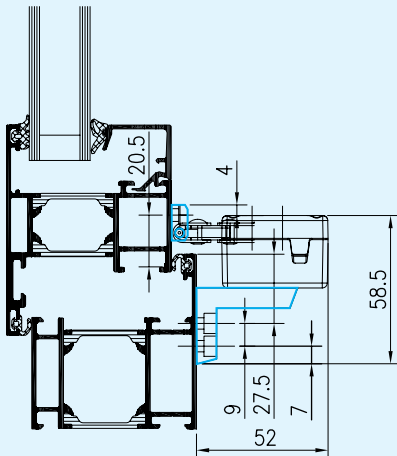

WAB 804 0101

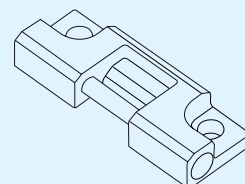

WAB 801

WMX 504 / 504 UL / 804 / 804 UL

CHAIN ACTUATOR

Installation suggestion 3

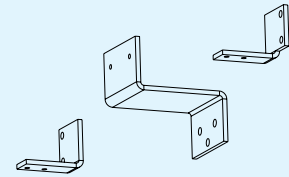
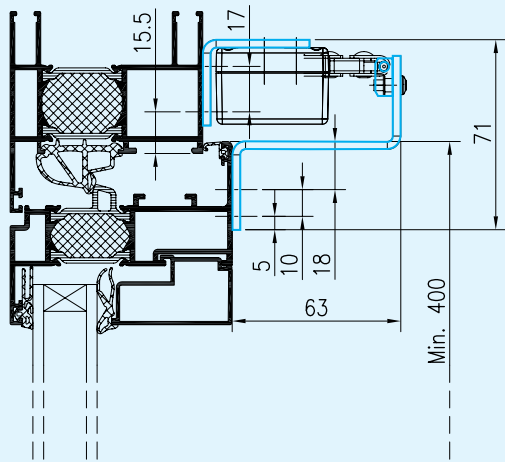

WAB 805

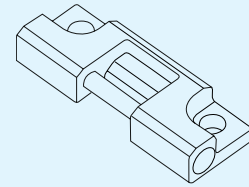

WAB 801

Installation suggestion 4

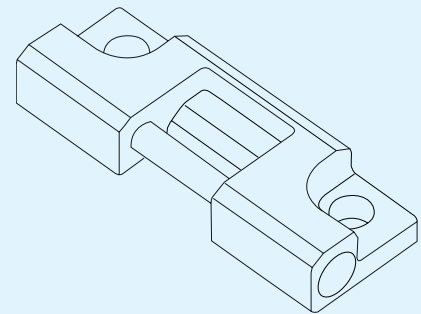
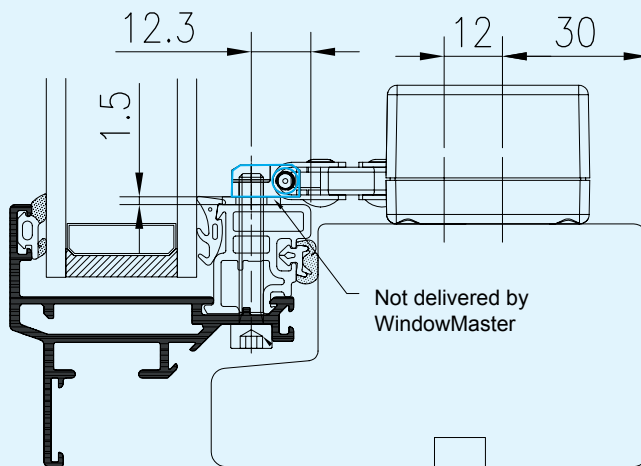

WAB 801

