

WMU 936-n

CHAIN ACTUATOR 300N 230VAC



Description

- designed for surface mounting
- for comfort ventilation
- to be used with tophung, bottomhung, pivot and turning windows
- Connection to existing electric installations as the window actuator runs on 230 VAC installations
- soft close function
- built-in electronic load switch-off/end stop
- electronic actuator with micro controller
- the actuator has an integrated reverse function to ensure a prolonged life span of the window gaskets
- easy mounting

Pressure safety function

The risk of entrapment is reduced as the actuators are programmed to reverse if they encounter obstacles when closing.

Pressure force	see pressure/tractive diagram
Tractive force	300N
Locking force	3000N
Chain stroke	400, 600, 800 and 1000mm
Opening speed	11mm/s
Window types	tophung, bottomhung, pivot and turning windows vent size should be confirmed with the window supplier and WindowMaster
Voltage	230 VAC ±10%, 50/60Hz, max. 50VA
Starting current	6A<1mSec
Insulation / earthing	the actuator is a double insulated class II product which means it will not require earth connection
Operating conditions	-5°C - +45°C max. 85% relative humidity (not condensing)
Switch-on-duration	ED 40% (max. 4min. pro 10min)
Material	aluminium housing with stainless steel chain and 1.9m white cable 3-core 0.75mm ²
Colour	anodized aluminium, RAL colours available at an additional price
Size	34 x 47mm (H x D), (L) length depends on chain stroke – see table
Weight	400mm - 2.8kg, 600 mm - 3.2kg, 800mm - 3.6kg, 1000mm - 4.0kg
IP rating	IP32
Fire test	tested according to DIN 18232-3, section 3.6 (300min./300°C)
Delivery includes	actuator with 1.9m cable
To be ordered separately	actuator and chain bracket
Note	we reserve the right to make technical changes

Items			
Chain stroke [mm]	Compressive force [N]	Length [mm] (L)	Item-no.
400	300	719	WMU 936-1 0400
600	300	819	WMU 936-1 0600
800*	0N - only for bottom hung windows	918	WMU 936-1 0800
1000*	0N - only for bottom hung windows	1019	WMU 936-1 1000

Brackets	Item-no.
Actuator bracket for WMU 836 / 936 / 866	WAB 836A
Actuator bracket for WMU 836 / 936 / 866	WAB 836B
Chain bracket for WMU 836 / 936	WAB 836E
Chain bracket for WMU 836 / 936	WAB 811
Actuator bracket for WMU 836 / 936	WAB 812
Actuator bracket 43mm	WAB 824
Z-Bracket for inward-opening windows	WAB 825
For further information, see the chapter "Brackets"	

Installation suggestion 1

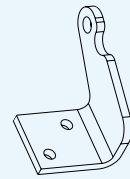
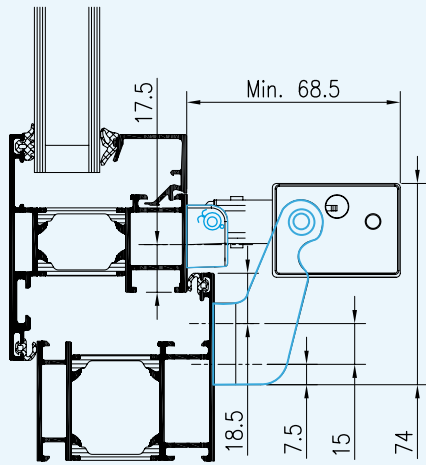

WAB 836B

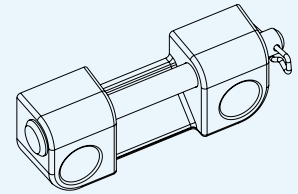

WAB 836E

Installation suggestion 2

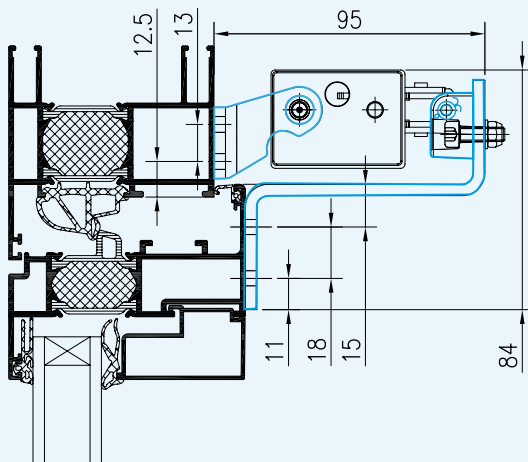

WAB 824

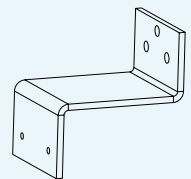

WAB 825

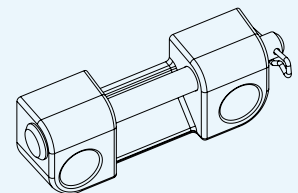

WAB 836E

Installation suggestion 3

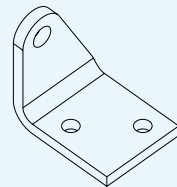
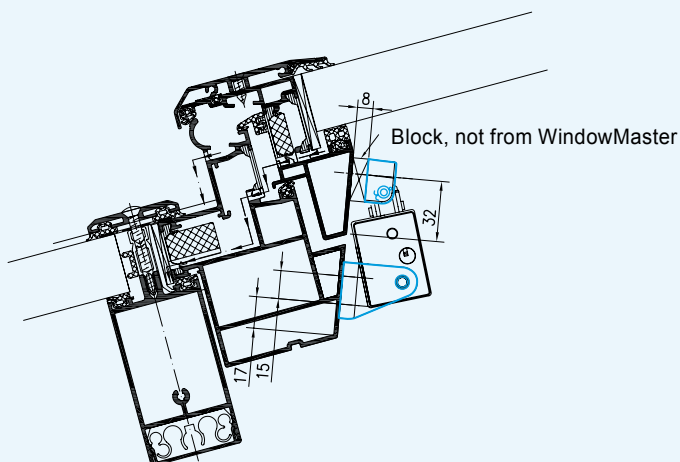

WAB 836A

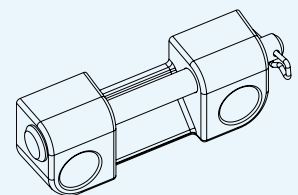

WAB 836E

WMU 936-n

CHAIN ACTUATOR 300N 230VAC

Installation suggestion 4

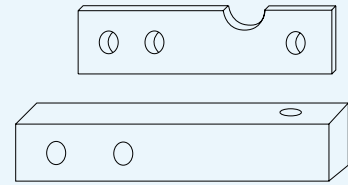
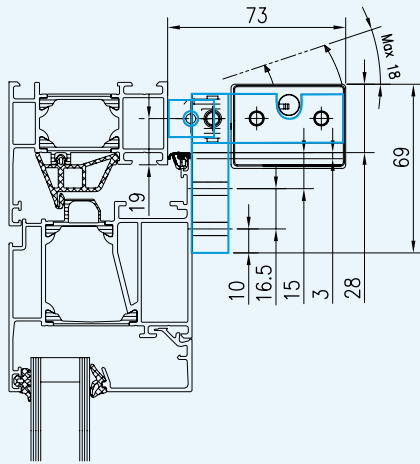

WAB 812

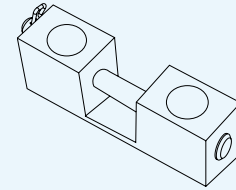

WAB 811

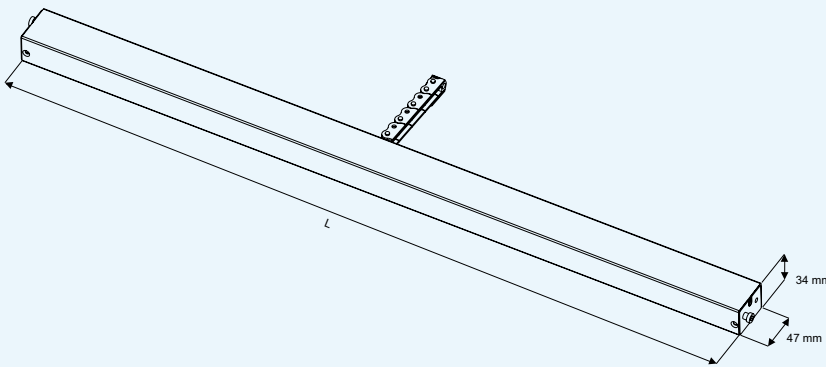

L = Length, see table for items

