

Semi-Recessed / Anti-Ligature

Typical Installation: Build a frame to support the back plate that is spaced 42mm +1/-0 from front wall face.

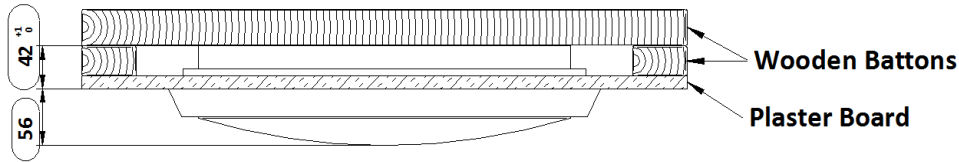

Cut Hole in wall at 415mm diameter and centralise back plate with cut aperture and fix back plate to frame using suitable fixings.

NB: - Remove O ring gasket from body. Fit will be restricted if left in situ.

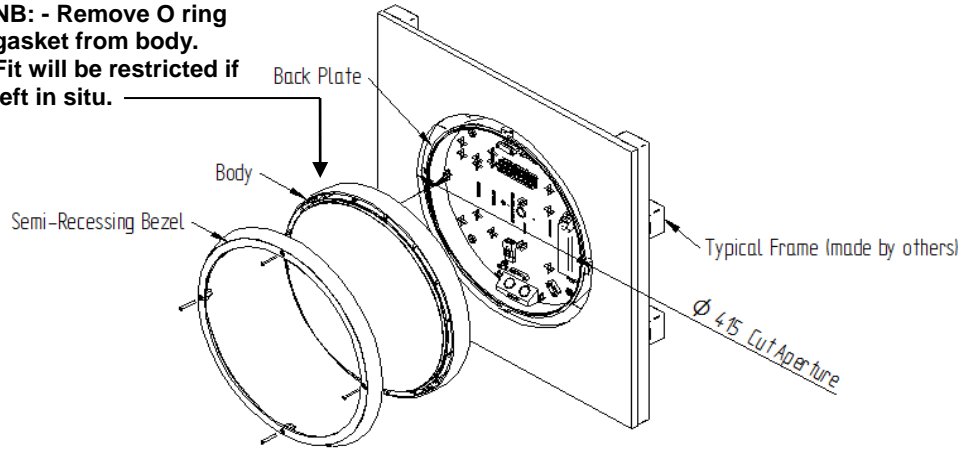

Remove O ring gasket from body and discard.

Twist the main body on to the back plate and screw the semi-recessing ring in place. Using the 4 screws provided.

NB: - IP44 compliance only in this configuration

GENERAL INFORMATION

- 1) A qualified electrician, in accordance with IEE wiring regulations should carry out connection to mains wiring.
- 2) Ensure that the rated voltage and frequency requirements are compatible with the available mains supply.
- 3) Do not carry out high voltage insulation test, i.e. 500/1000v this may damage internal components.

TECHNICAL SUPPORT

Telephone: 0161 331 5700

E-mail: technical@whitecroftlight.com

<http://www.whitecroftlighting.com/>

Whitecroft
lighting

Kolo



Installation Instructions

PK/LFTKOLO

Revision L JAN 2018



Whitecroft Lighting Limited

Burlington Street, Ashton-under-Lyne, Lancashire OL7 0AX
Telephone +44 (0)870 5 087 087 Facsimile: +44 (0)870 5 084 210
www.whitecroftlighting.com

Registered No. 3848973 England

Registered Office: As above

SPECIFICATION

Lamp types	800lm 4000K
	1100lm 4000K
	1700lm 4000K
	2300lm 4000K
Materials	Polycarbonate Diffuser
	Polycarbonate back plate (Metallic Silver or White RAL 9003) and Cast Aluminium main body (Metallic Silver or White RAL 9003)
Supply	240V
Power	800lm 11W
	1100lm 15W
	1700lm 15W
	2300lm 21W
Operating temp	-5°C to 25°C
Connection	Terminal block 0.75mm ² to 2.5mm ²
Ingress protection	IP44 / IP65 dependant on variant.

DIMENSIONS

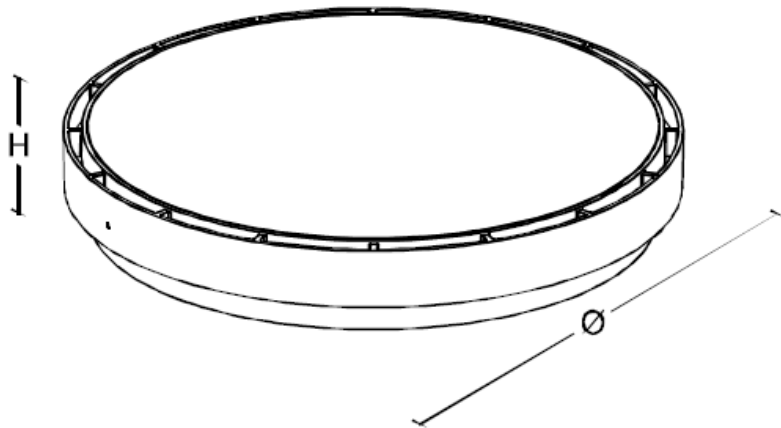

Version	Ø	H	CAØ	KG	KG (EM)
300mm recessed	320	130	310	2.0	2.5
300mm surface	300	92	-	2.0	2.5
400mm recessed	420	130	410	3.4	3.8
400mm surface	400	92	-	3.4	3.8
400mm + Anti-Ligature kit	467	92	-	3.6	4.0

IP65 Components

The IP65 variants have a potted diffuser (please note that if removed the IP rating is compromised and will need re-potting) and an IP65 'O' ring fitted to the rear of the casting.

The additional components provided for IP65 rating are;

- 2 x Rubber grommets
- 4 x Rubber washers
- 4 x M4 Screws

These components will need to be fitted ahead of installation, the four rubber washers should be fitted into four recesses as shown on pages 3 & 4. If the product is to be surface mounted the back plate should be drilled first.

The diaphragm will need piercing before the cable is threaded through the grommet;

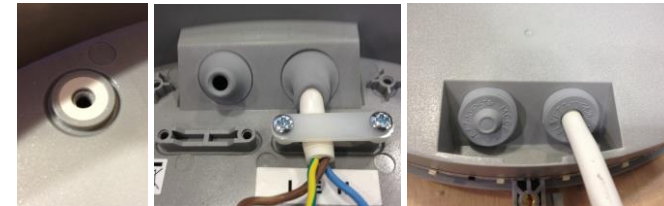

The rubber grommets should be fitted as illustrated as above, ensuring that they are fully in position as this may compromise the IP rating of the luminaire.



For conduit entry break tab in moulding.

INSTALLATION DETAILS (STANDARD)

Firstly, unpack the luminaire please note that the diffuser / casting half of the product is not fixed to the base so remove and place face down on soft surface (e.g. lid of carton) so that the diffuser front surface does not get scratched.

Please note that if a trim ring attachment is to be fitted, it should be attached before the luminaire is installed (see 'TRIM RING' section on page 7)

SURFACE MOUNTED

To surface mount the product please drill through the four illustrated holes on the back plate, please note that if you have an IP65 variant please drill before the rubber washers are inserted. This can then be used to mark the hole positions on the designated surface. Please use suitable fixings for mounting.

400mm Ø

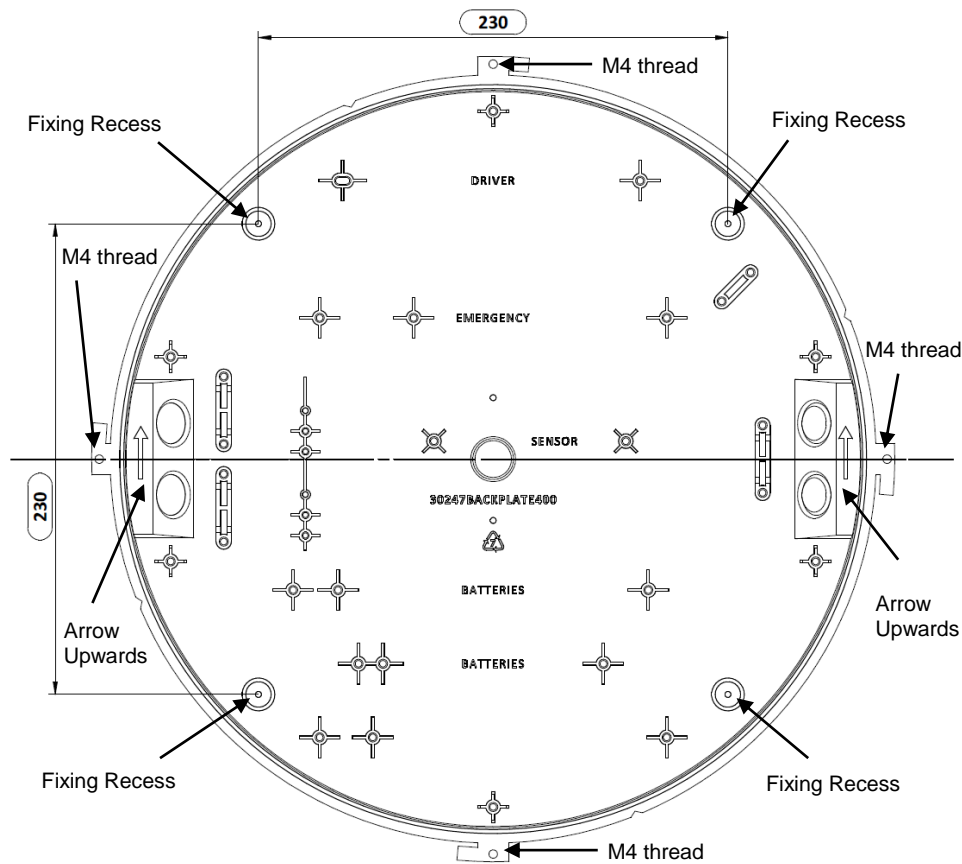

300mm Ø

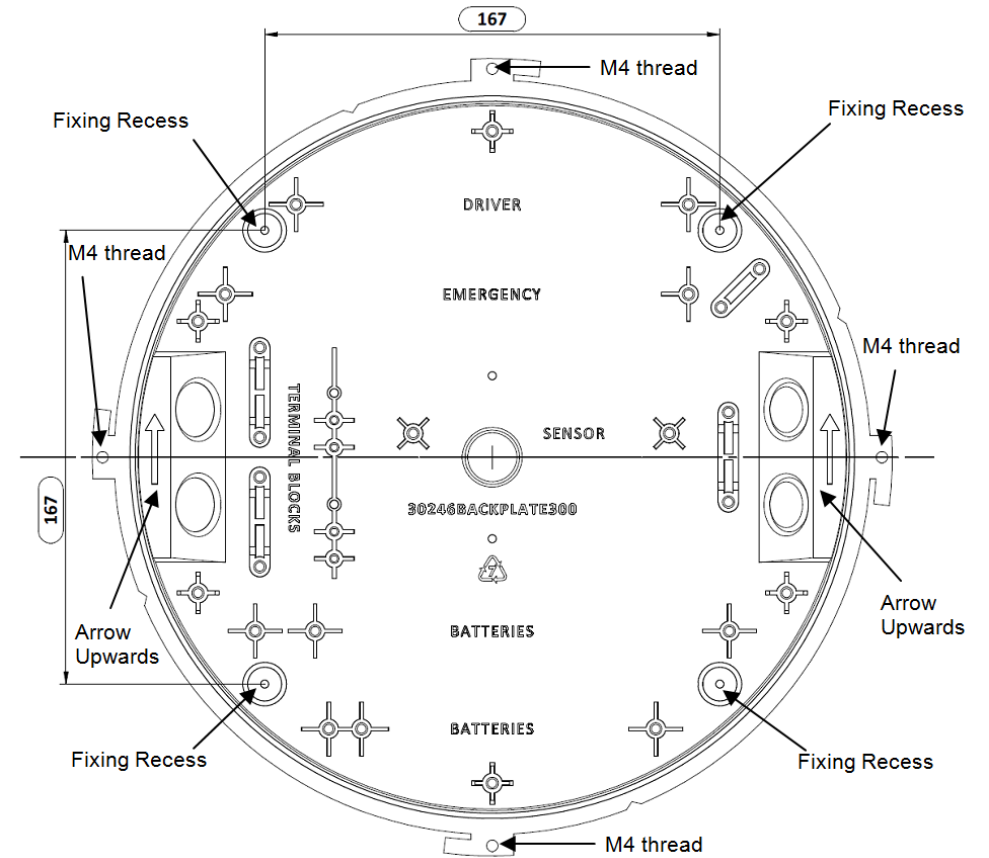

Please ensure that the back plate moulding is fixed with the arrows pointing upwards, once the back plate is secured into position the mains cable should be fed through the aperture on the moulding and wired into the terminal block.



Please note that if a trim ring attachment is to be fitted, it should be at this point (see 'TRIM RING' section on page 7)

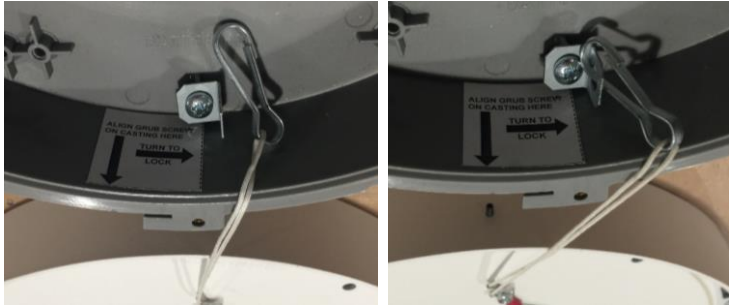

Attach the dog hook cable first to the metal bracket and then the yellow connector block(s) can now be fitted together. The battery pack should be connected if you have an emergency variant.



If you have an IP65 variant please check that the grommets and the 4 x rubber washers are correctly fitted and not damaged prior to fitting the casting to the back plate as this could compromise the IP rating of the luminaire.

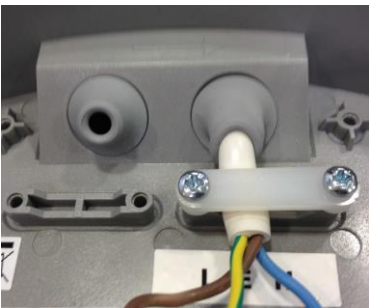

Partially fit the grub screw into the casting (as this will aid the assembly of the product), once this is done use the protruding screw and align to the arrow label on the inside of the back plate moulding, offer the casting up to the back plate and then turn anti clockwise until it locks into position;

NB: - Grub screw not required on IP65 variants and should not be fitted

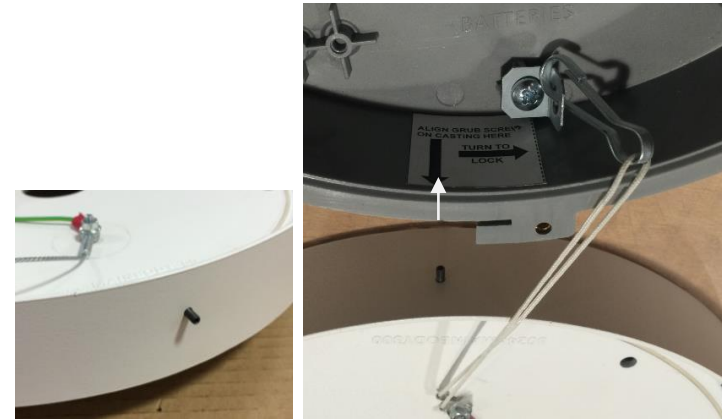

If your product is an IP65 variant you should use the provided 4 screws to secure the top casting to the half back plate.

It is important that this is tightly screwed into place as the IP rating of the product could be compromised if not.



When in place use the Allen key to fix the grub screw into place and please ensure that it is flush with the surface. **(Not required on IP65 variants)**

TRIM RING

The Trim ring kit (sold separately) should contain the following parts;

- 1 x Trim ring bezel
- 6 x Keyhole clips
- 2 x M4 Screws

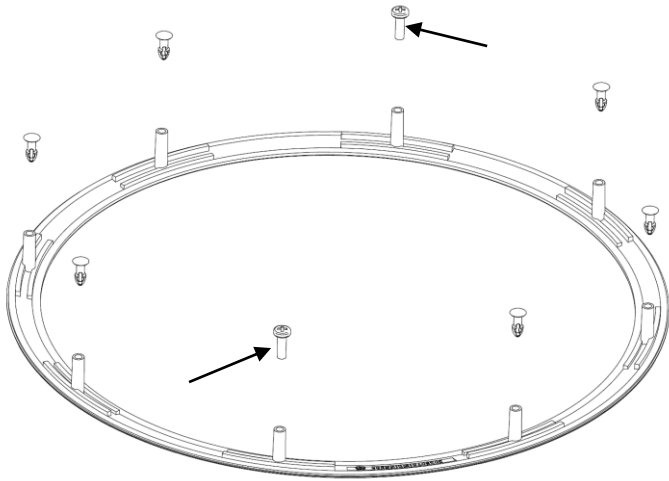

Please ensure that the casting is detached from the back plate moulding and then fit the Trim ring over the casting so that the pillars align with the screw housing detail (see below). Once this is done fix the attachment with the M4 screws at opposite sides (as illustrated above). The keyhole clips can then be fitted into the remaining pillars and pushed down to fully secure the Trim ring accessory into position. Then follow the surface mount instructions.



SUSPENDED

The suspension kit (sold separately) should contain the following parts;

- 3 x Flanged cups
- 3 x Round cups
- 3 x Steel suspension cables
- 3 x Cylindrical clutches
- 2 x Washers
- 2 x Nuts
- 1 x Suspension plate

Firstly the suspension plate can be used to mark out the fixing points on the ceiling from which the luminaire will hang; a terminal screw driver can be used to mark the three points. The product can either be wired through the centre or via the side apertures.

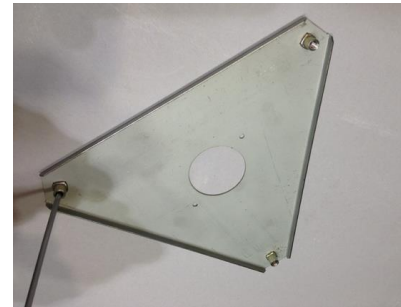

To attach the suspension plate to the product two holes should be drilled to accommodate the M4 screws that are provided. The plate should be secured on the inside with the washers and nuts provided.

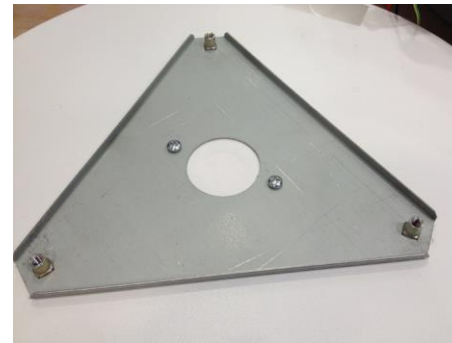

Please ensure that this is fully secured with the provided flange nuts and washers on the inside of the product before fully suspending (as illustrated above).

SUSPENDED

The cylindrical clutches can now be threaded into the suspension plate.

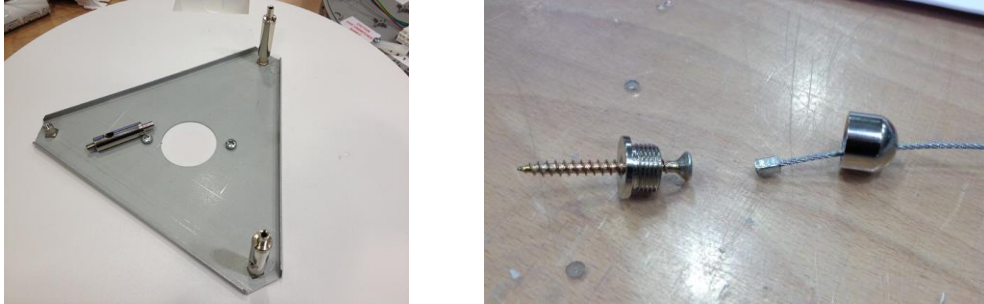

Screw the three flanged cups into the drilled holes in the ceiling. Thread a suspension cable through each of the round cups as shown and then screw the cups onto the fixed flange cups. Please use suitable ceiling fixings for suspending.

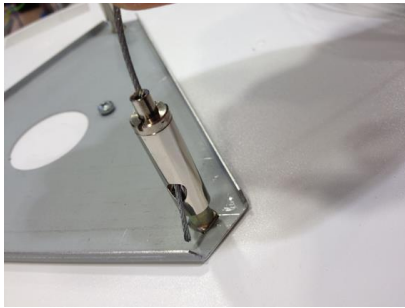

Offer the back plate up to the hanging suspension cables. Thread each cable through its corresponding clutch mechanism to the desired height, then level off the back plate and trim the excess cable.

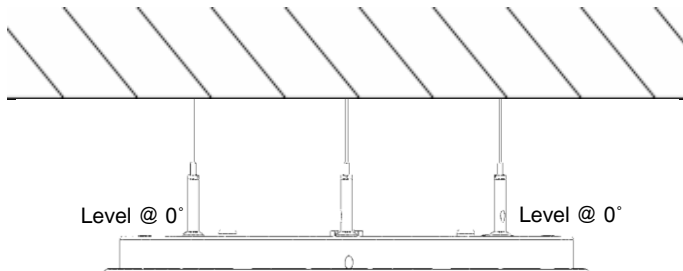

Now refer back to pages 5 and 6 for securing any electrical connections and attaching the casting to the back plate and if a trim ring is being used then please add this before fitting. Two people will be required to lock the casting into position whilst the product is in its suspended state.

ANTI-LIGATURE

The Anti-ligature kit (sold separately) should contain the following parts;

- 1 x Anti-ligature bezel
- 4 x M4 Anti tamper screws

Attach the product to the surface as per the surface mount instructions and then fit the anti-ligature bezel over the base ensuring that the screw holes are aligned with the threaded inserts on the product.

It may be worth positioning the screws into the moulding ahead of fixing down and also a separate H40 insert bit is required for fixing these components. A cordless driver is recommended for this operation.

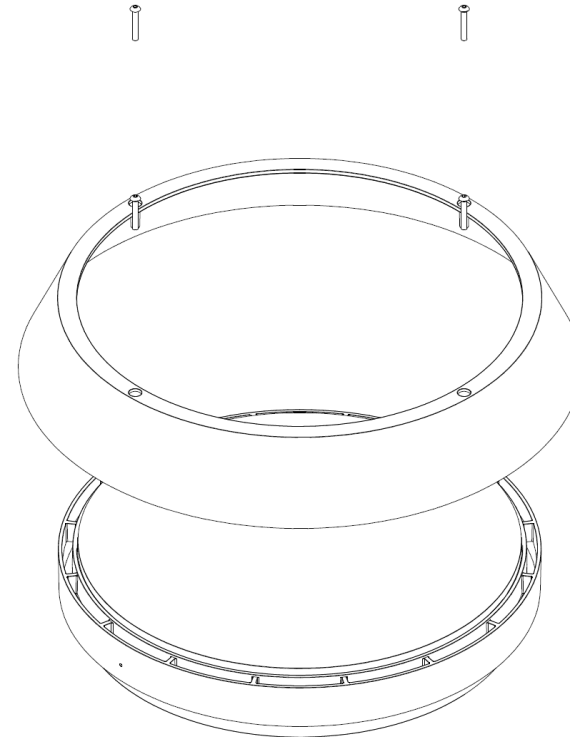

When tightening the anti-ligature screws please ensure that the bezel moulding is completely flush against the mounting surface.

RECESSED

The Recessing kit (sold separately) should contain the following parts;

- 4 x Bracket/spring assemblies
- 4 x M4 screws
- 1 x Female GST plug
- 1 x Male GST plug
- 1 x Recessing bezel

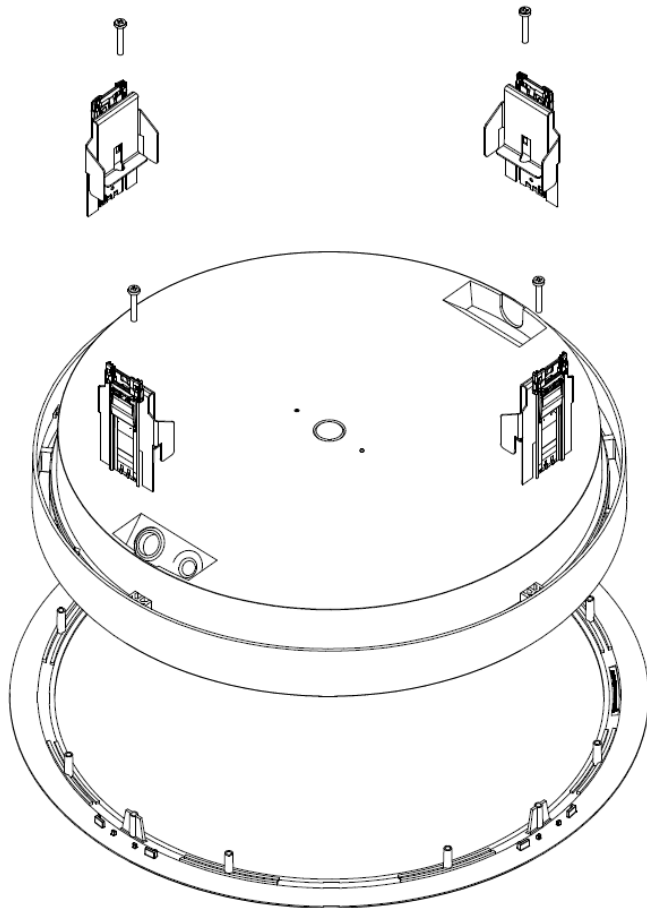

RECESSED

Assembly

It is advisable to pre wire the unit before installation using the female GST plug provided on the luminaire (and use the male GST on the mains supply line), follow the standard installation as shown on page 5 ensuring that the product fully wired and connected before fitting the Recessing kit. Please place on a soft surface so that the diffuser does not get damaged when the product is placed face down for this task.

The Recessing bezel should be fitted over the product so that the reinforced screw bosses align with the threaded inserts on the product. Partially screw down with the M4 screws provided and then hook the Bracket assembly over the screw and then screw securely into place ensuring the brackets are fully seated behind the plastic (as seen below).



Please ensure that there are no gaps between the bezel and the luminaire when secured and it is advised that the product and bezel are held together when fixing the screws to ensure that the product is correctly fixed together.

Ceiling Specification

An advisable ceiling specification for the Recessed variant would be a typical plasterboard type of a depth between 12 and 36mm.

Important Note!

This product is not suitable for installation into unsecured ceiling tiles due to the excessive force required to ensure the front face is secured correctly.

RECESSED

Installation

1. Cut a ceiling aperture to 315mm Ø (+/- 1mm) for the 300mm Ø product and 415mm Ø (+/- 1mm) for the 400mm Ø product.

2. Remove the protective tape and then activate the mounting springs by pressing the area illustrated below, a 'click' should be heard and the spring levers will rise into the 'mount' position. Be very careful not to touch the spring while it is in this state.

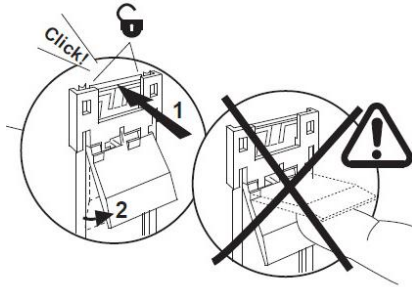

3. Feed the luminaire unit into the ceiling aperture so that the spring levers are beyond the ceiling (see below).

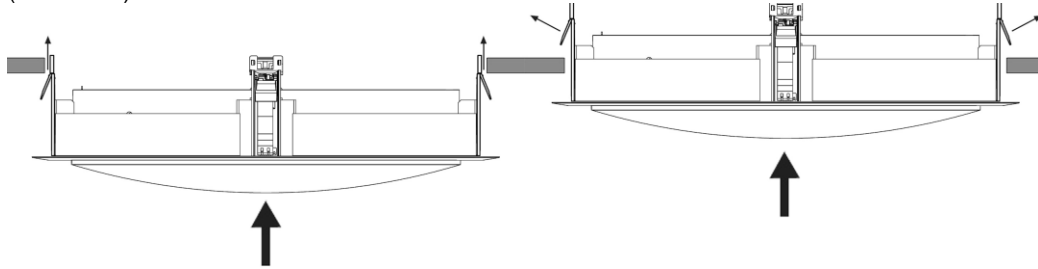

4. Gently pull the luminaire unit down, keeping it level and this should fully activate each of the mounting springs, listen out for four audible 'clicks'. The unit should then be guided up by hand so that there are no visible gaps around the bezel and so that the product is centrally positioned in the aperture. **Please note that the springs can be re-set by carefully pulling the levers up until a 'click' is heard (refer back to step 2 above).**

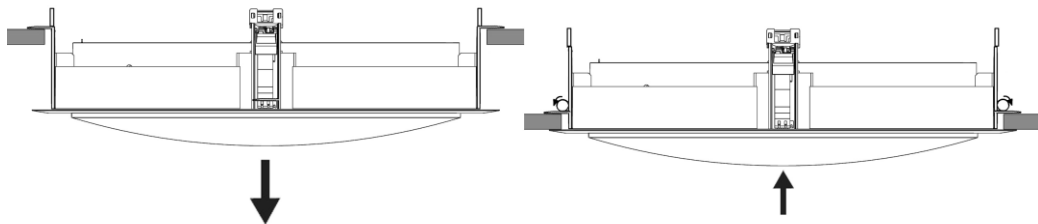

Removal

To remove the luminaire pull the unit down (keeping level), run your fingers around the bezel and pull it downwards from where the brackets are located (anywhere else may flex and damage the bezel). Lower the product until a 'click' is heard from each of the four springs, this will de-activate the mechanisms. Push the luminaire back into the ceiling to allow the spring levers to drop back down; the product will now pass through the ceiling aperture.

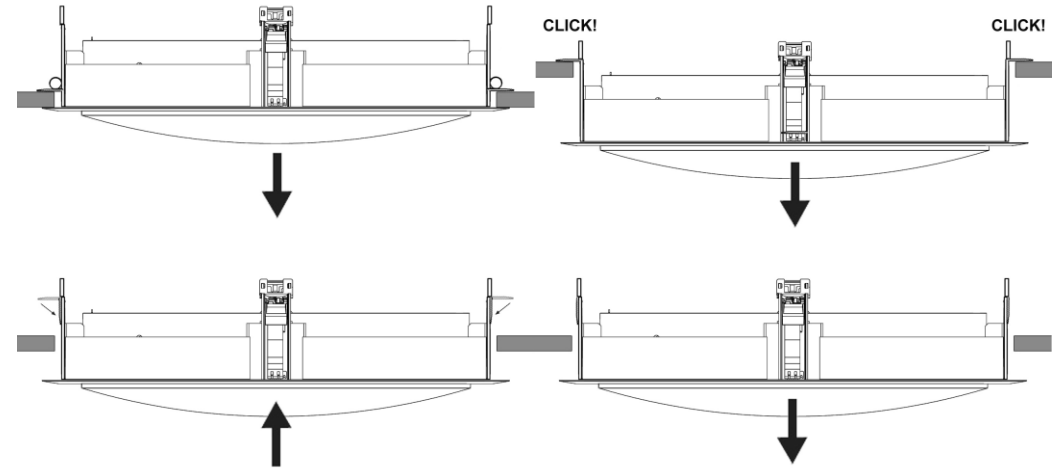

DIMMING LEVEL SETTINGS

For the Q5 variants the driver can be configured to the desired dimming level via the dip switches located at the end of the driver (see below).

Please note that only the 400mmØ Q5 variants have this feature.

LED Current Selection

The 3 dip switches on the left will be pre-set to suit the output of the luminaire.

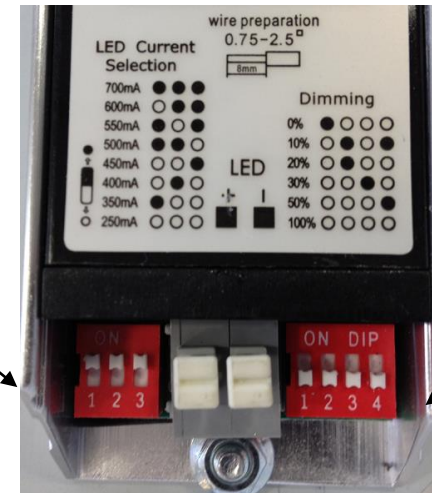

Dimming level set up

The 4 dip switches on the right can be configured to suit the desired dimming level e.g. 0%, 10%, 20%, 30%, 50% and 100%.

Exterior accessories

TRIM RING (300mm & 400mm Ø)

The Trim ring kit (sold separately) should contain the following parts;

- 4 x M4 screws
- 1 x Trim ring cast aluminium bezel (300mm or 400mm Ø)
- 1 x Allen key

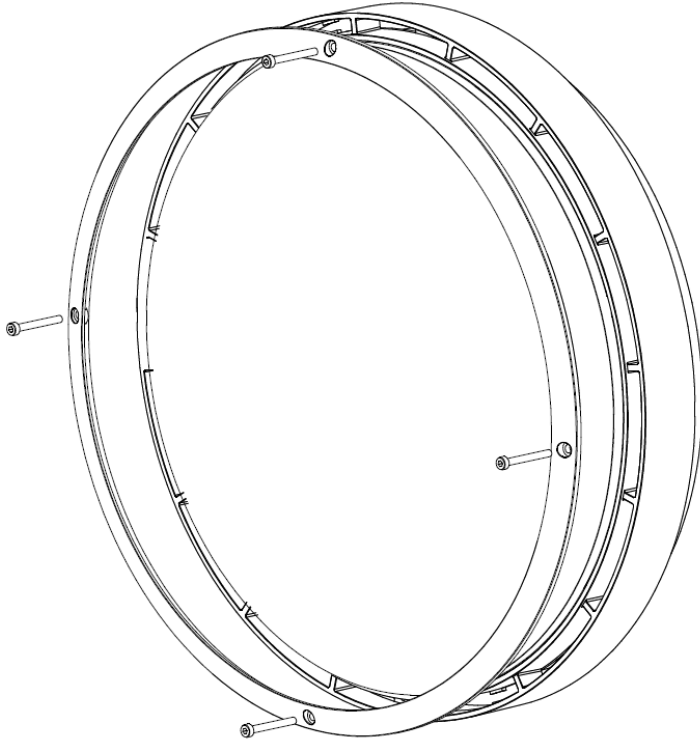

Attach the product to the surface as per the surface mount instructions and then fit the trim ring bezel over the base ensuring that the screw holes are aligned with the threaded inserts on the product. Tighten the provided screws with the size 3(mm) Allen key not provided.

Exterior accessories

GRILL ATTACHMENT (300mm & 400mm Ø)

The Grill attachment kit (sold separately) should contain the following parts;

- 4 x M4 screws
- 1 x Grill attachment cast aluminium bezel (300mm or 400mm Ø)
- 1 x Allen key

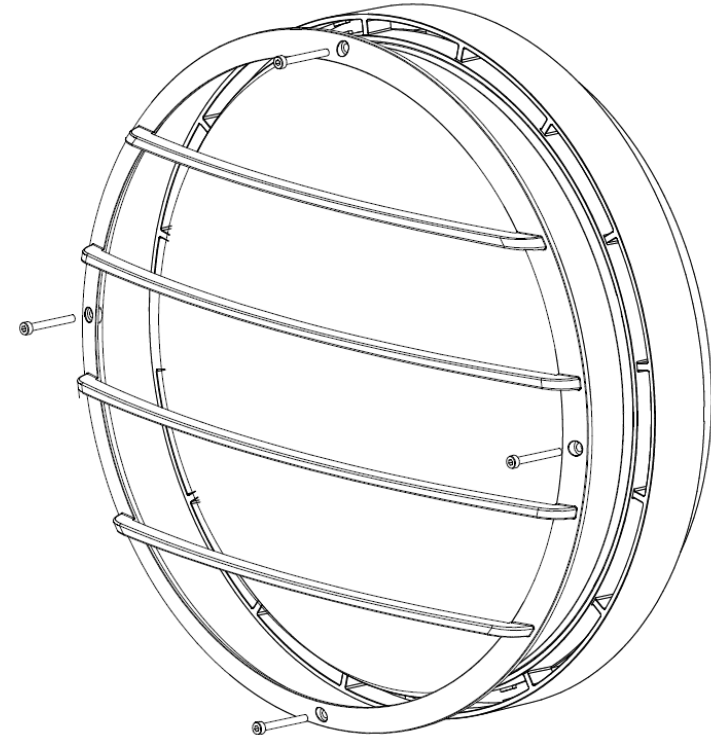

Attach the product to the surface as per the surface mount instructions and then fit the Grill attachment bezel over the base ensuring that the screw holes are aligned with the threaded inserts on the product. Tighten the provided screws with the size 3(mm) Allen key provided.