

# Gyrus

Adjustable downlighter

Whitecroft  
lighting

IP20

LED



Double



Triple

## Optics

- Light Output Options:
  - Single downlight: 500 lumens (10W)
  - Double downlight: 1000 lumens (19W)
  - Triple downlight: 1500 lumens (30W)
- Flood or spot distribution options for precise lighting control
- Available with 3000K and 4000K LED

## Body

- Available in single, double or triple configurations
- Circular downlight within a square/rectangular bezel
- Aluminium body and bezel finished in brushed aluminium
- Rotates 360° and tilts 0-45°
- Suitable for ceiling thicknesses of 1-20mm
- IP20

# Order codes

## Flood Distribution

Flood Distribution	Fixed Output	LL/CW	L70
Single, 500 lumens (10W)	GYSNH4KFL	53	50k
Double, 1000 lumens (19W)	GYDBH4KFL	53	50k
Triple, 1500 lumens (30W)	GYTRH4KFL	53	50k

Note: Luminaire codes GYDBY4KFL and GYDBY4KSP have 2 drivers and require 2 DALI addresses  
 Note: Luminaire codes GYTRY4KFL and GYTRY4KSP have 3 drivers and require 3 DALI addresses

## Options

DALI DIMMING	Replace H with Y	i.e GYSNY4KFL
SPOT DISTRIBUTION	Replace FL with SP	i.e GYSNH4KSP

For 3000K colour temperature, please contact Whitecroft

## LED Performance

Colour Temp	RA (CRI)	Colour consistency
4000K	>80	MacAdam 4 SDCM

## Dimensions

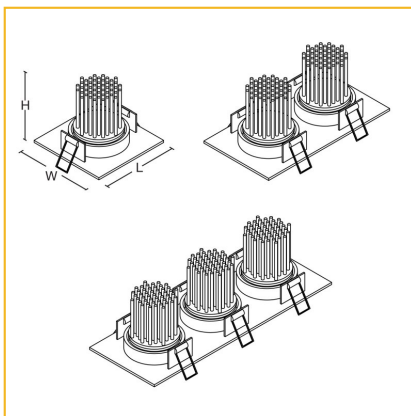

VERSION	L	W	H	KG	Cut Aperture
Single	92	92	85	0.3	85x85
Double	172	92	85	0.5	155x80
Triple	252	92	85	0.7	235x80

## Photometric Performance

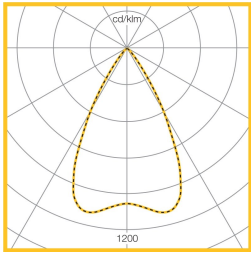

4000K 500  
Lumens, 10W,  
Flood  
LOR = 100.0%  
SHR MAX = 1.17

---

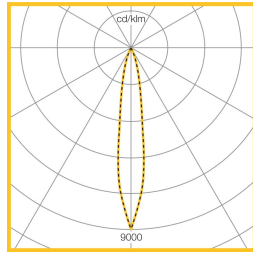

4000K 500  
Lumens, 10W,  
Spot  
LOR = 100.0%  
SHR MAX = 0.75

---

---

## To Specify

Recessed high output LED directional downlight with flood or spot light distribution. Aluminium body with integral LED light engine and remote driver for flexibility and rapid installation. For ceiling thicknesses of 3-17mm supplied complete with driver – as Whitecroft Lighting GYRUS

---