

7. Push the driver enclosure back into place onto the heat sink and tighten the gland onto the mains cable to hold the housing in place as per fig 10.

Please note that the earth fixing on the top surface of the driver enclosure must line up above the terminal block to ensure a correct fit.

8. Cut the suspension cable to length and then feed into the EchoLED luminaire clutches as fig 12. 20-30mm of suspension cable can fit into the housing and can be trimmed at a later point.

Please note that the driver enclosure must be on the luminaire before the suspension cable can be fed through.

Please note: All images shown are for illustration purposes only and should be used as a reference guide.

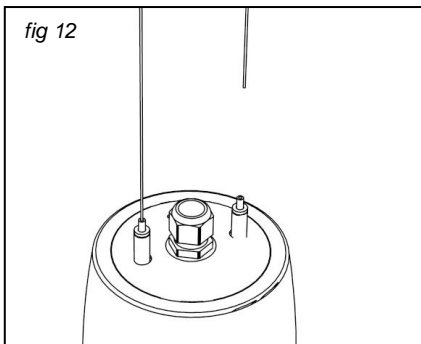

TECHNICAL SUPPORT

Tel: 0161 331 5700

E-mail: technical@whitecroftlight.com

whitecroftlighting.com

GENERAL INFORMATION

- 1) A qualified electrician, in accordance with IEE wiring regulations should carry out connection to mains wiring.
- 2) This unit must be EARTHED.
- 3) Ensure that the rated voltage and frequency requirements are compatible with the available mains supply.
- 4) Cleaning of reflectors and lenses should be carried out using clean, soft and lint free cloths and anti-static cleaning fluid
- 5) Do not carry out high voltage insulation test, i.e. 500/1000v this may damage internal components.
- 6) The EchoLED luminaire must be suitably positioned to avoid high temperatures.
- 7) Temperature range for the luminaire is 0 - 25°C.
- 8) All mains supply cables connected to EchoLED luminaire must be kept as short as possible and should be of a HAR approved heat resisting type.
- 9) The EchoLED luminaire is not supplied with cable, but will accept 3 core double insulated cable from 0.5mm to 1.5mm CSA.
- 10) Supply cables and lamp circuit cables should be physically segregated, and all LED drive/indicator cabling kept as far away as possible from any other lamp wiring.



EchoLED Installation Leaflet



PK/ILECHOLED COB

July 2015 – REV03



Whitecroft Lighting Limited

Burlington Street, Ashton-under-Lyne, Lancashire OL7 0AX
Telephone +44 (0)870 5 087 087 Facsimile: +44 (0)870 5 084 210

Registered No. 3848973 England

Registered Office: As above

SPECIFICATION

EchoLED is a suspended luminaire available in a silver anodised finish with a variety of lumen packages and DALI dimming as an option.

It is available with 3 different refractor/ reflector options – Opal, Clear and Spun Aluminium.

Dimensions (mm)	H1	H2	H3	OD	Weight
EchoLED	460	175	443	300	4.5kg

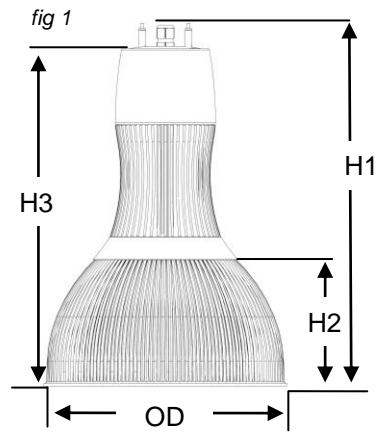

INSTALLATION INSTRUCTION

1. Remove the EchoLED housing from its carton as per fig 2 and visually inspect surface finish for defects. The package will include.

- 1 x EchoLED housing
- 1 x Suspension kit
- 1 x Installation leaflet

The refractor/ reflector will always be shipped separately.

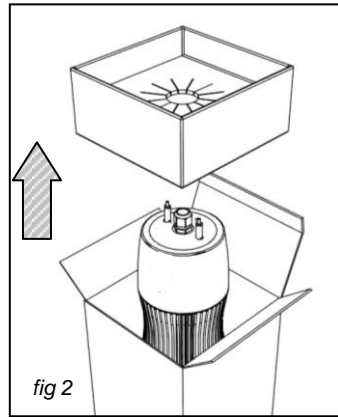

2. Slide the driver enclosure over the suspension clutches as per fig 3, then feed the mains/ mains and DALI supply cable through the cable gland to the piano blocks.

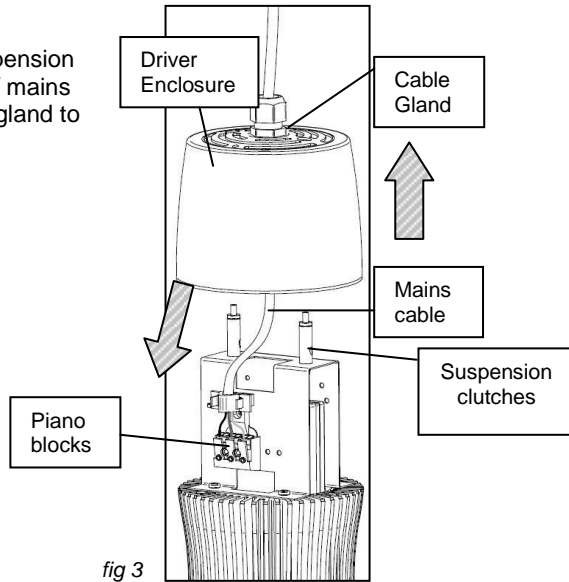

3. Wire the cable in as shown in fig 4 to the piano blocks, the maximum recommended cable cross sectional diameter is 1.5mm.

L	Live
E	Earth
N	Neutral

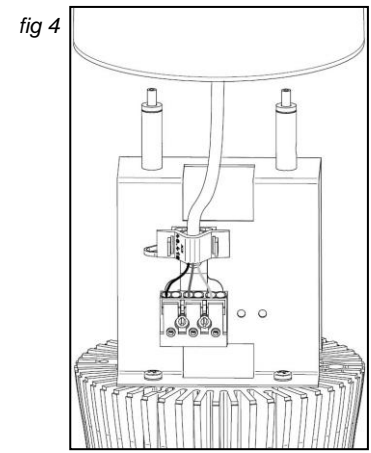

4. Clamp the mains cable beside the terminal blocks by pressing the plastic clamping block together onto the cable as in fig 5, the clamp will click into place.

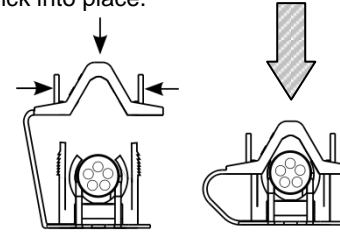
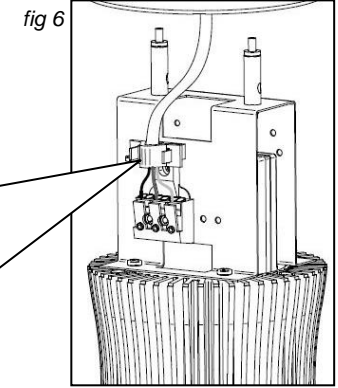

fig 5



5. Remove the collar by rotating see fig 7.

Place the refractor into the shade ring and refit collar as fig 8. Tighten using the supplied screws to secure the refractor in place.

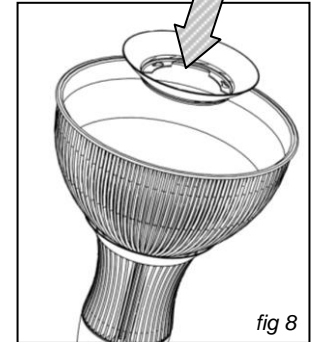
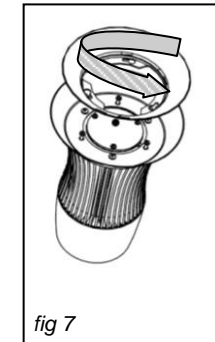

fig 7

fig 8

6. To suspend the luminaire, first fix the suspension bases to the ceiling as fig 9 using an appropriate method for ceiling type.

The base will allow up to a 4.1mm diameter screw. For centre points see fig 11.

Feed the suspension cable into the cover as fig 9 and screw the cover to the base.

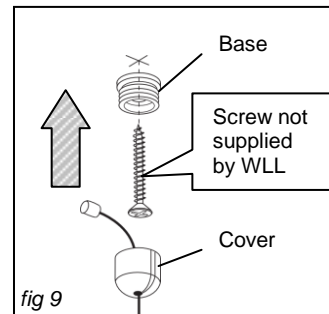

fig 9