

Command Plus Integral Module

COMPL4D for DSI ballasts
COMPL4Y for DALI ballasts



Note: COMAHP required for commissioning

Installation and Commissioning Instructions

Electrical Connections

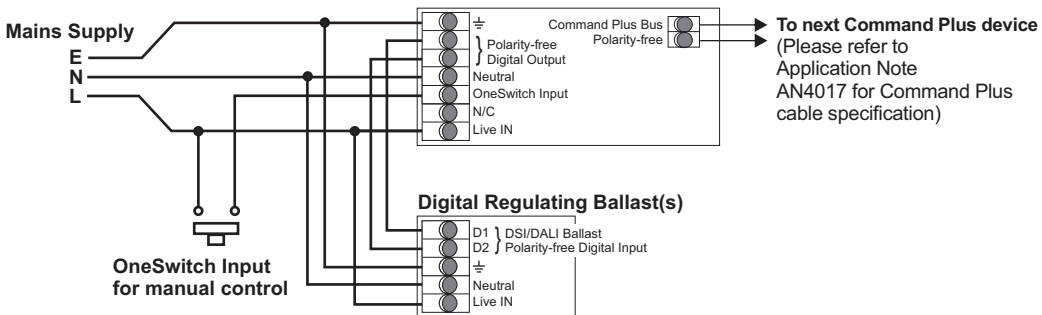
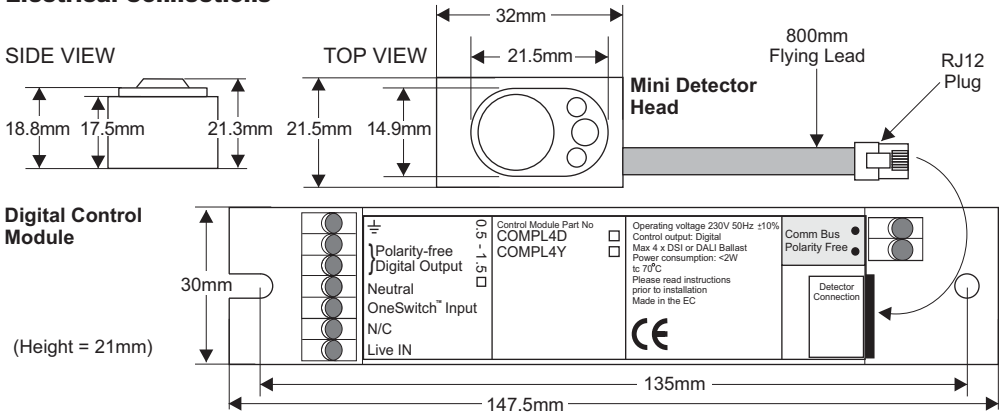

Mounting Details

The Control Module is designed to be mounted within a luminaire on fixing centres of 135mm. Connections to the control module as shown above should be made using solid strand wire (0.5-1.5mm²).

The interconnect cable between the detector head and the control module should be routed away from other luminaire internal wiring and away from the lamp end-caps.

The recommended position for the detector is in the middle of the luminaire. Where this is not possible and the detector is fitted near one end of the lamps, please ensure that the detector is at the 'cold' end of the lamps.

The Mini Detector Head should be mounted such that only the raised front section of the bezel protrudes through the cut out in the louvre or infill panel, constructed in accordance with the dimensions above.

Installation Guidelines

1. The Mini Detector Head must be mounted within the luminaire. Do not mount remotely.
2. The connecting cable must not be extended.
3. Artificial light illuminating the Mini Detector Head must only be reflected from the room, i.e. there must be no direct illumination.
4. In order to achieve satisfactory light-level regulating operation, a detector must observe a substantially greater proportion of artificial light from the luminaire(s) under its control than from neighbouring luminaires not under its control. This is particularly important when planning the installed layout of linear luminaires that have an integral detector positioned at one end.

Commissioning

Detectors are supplied factory pre-set which ensures the lighting will switch on automatically as soon as power is applied. Final commissioning of the detectors requires the use of the COMAHP Programmer.

Commissioning Detectors using the COMAHP Programmer

It is important that the Programmer be held perpendicular and at a distance of between 0.5m and 2m from the detector.

1. Switch on by pressing any button (and unlock with top left rectangular button).
2. Point the programmer at the detector and press the DOWNLOAD button. The programmer will confirm the product's identity and call up the correct menu of parameters and its current settings.
3. Use a combination of UP, DOWN, FORWARD and BACK buttons to navigate the parameter menu, selecting options for each shown.
4. When options for all parameters have been selected, point the programmer at the detector and press the UPLOAD button. The luminaire(s) will switch off briefly during the programming process.
5. After a short period of inactivity (default 5 minutes), the programmer hibernates retaining the most recent settings.

OneSwitch Dimming

OneSwitch dimming affords local control to the end-user whereby a simple, momentary, push-to-make wallswitch can be used to raise or lower the lighting level or to toggle the output ON/OFF. A press of less than 1 second will toggle the output status while a longer press will raise or lower the output. Each time the switch is pressed, the direction of dimming reverses. If the switch has not been pressed for 5 seconds, the direction will be up (brighter) - unless the output is already above 90% in which case the direction is down. A wiring diagram is shown left.

To Test with COMHC Hand-held Controller

Once the Command Plus Luminaire Controllers have been installed within the luminaires, the COMHC may be used to dim and brighten luminaires and to switch them ON and OFF. One of 6 different lighting scenes can also be recalled.

Important Additional Notes

1. A means for disconnection must be incorporated in the fixed wiring in accordance with the current wiring regulations.
2. Although nominally 12V, the dimming output is not SELV and therefore should be treated with the same respect as mains with regard to wiring practice. The 0V line of the dimming output is almost at Neutral potential.
3. The dimming control output should be connected only to the control input of the ballasts - never to other detectors.
4. This equipment should be used to control only those ballasts powered from the same phase as the detector.
5. Do not connect mains to the Command Plus bus.
6. It is imperative that the Command Plus bus is wired with the correct type of cable; normally it should be 1.5mm² unscreened twisted pair. Please read Application Note AN4017 for more details.
7. Due to the fact that the photocell is on the ceiling looking down, it is not possible for measurements made with a lux meter on the working plane to remain constant when daylight illuminates the ceiling and the working plane to a differing extent. Therefore, products of this type should be regarded as capable of maintaining an APPROXIMATE light level only.
8. This equipment switches lights no more frequently than would a responsible human occupant. However, manufacturers of some particular lighting types (e.g. '2D' luminaires) may specify a maximum number of switching cycles in order to achieve a predicted lamp life. Please check with the manufacturer of the luminaires to ensure that they are compatible with automatic controls in this respect.
9. Some devices in this product range feature a silvered surface finish; this is intended for decorative purposes only. Care should be taken to avoid accidental separation of the silvered coating from the product. If the unit is built into a luminaire that is subsequently wrapped in film having adhesive properties, it is recommended that a layer of suitable packaging material be used to protect the silvered area.

Technical Data

COMMAND PLUS CABLE: 1.5mm² unscreened twisted-pair : see Application Note AN4017

MAXIMUM RECOMMENDED MOUNTING HEIGHT: 3.0m

RANGE: Cone-shaped detection pattern, diameter (at floor level) = 2.4 x mounting height

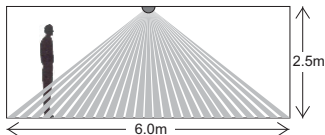

OPERATING VOLTAGE: 230V 50Hz (UK & Europe)

ta = 0 - 50°C

CAPACITY: 4 ballasts max (DSI Digital or DALI)

INTERCONNECT CABLE TEMPERATURE RATING: 60°C

COLOUR: Silver bezel (Detector Head)

MATERIAL: UV stabilised polycarbonate (Detector Head)

Flame retardant PC (Control Module)

IP RATING: 20

OVERALL DIMENSIONS: 32 (l) x 21.5 (w) x 21.3 (h) mm (Detector Head)

147.5 (l) x 30 (w) x 21 (h) mm (Control Module)

WEIGHT: 32g (Detector Head)

48g (Control Module)

FURTHER INFORMATION CONTACT TECHNICAL SUPPORT

Telephone: 0161 331 5700

E-mail: technical@whitecroftlight.com

<http://www.whitecroftlighting.com>