

## Detection Pattern

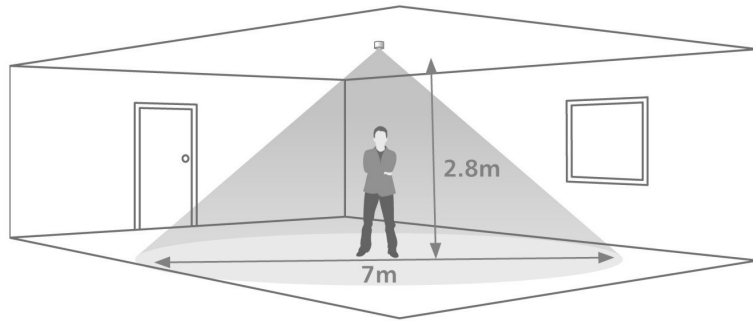

Area of high sensitivity  Area of lower sensitivity 

## Specification

### LOAD

8 Amp resistive and incandescent lighting  
 6 Amp fluorescent lighting  
 3 Amp compact fluorescent lighting  
 3 Amp low energy lighting  
 3 Amp low voltage lighting (switch primary of transformer)  
 Fluorescent lighting (max 6 fittings recommended)  
 For fluorescent lighting total power factor correction capacitance must not exceed 40µF.  
 3 Amp fans and ventilation equipment  
 Switch SON lighting loads via a contactor

**SUPPLY VOLTAGE** 220-240 Volts AC 50 Hz  
**TIME OUT PERIOD** Adjustable 10s to 30m  
**LIGHT LEVEL** Light to dark

**TERMINAL CAPACITY** 2.5 mm<sup>2</sup>  
**MATERIAL** Flame retardant ABS  
**TYPE** Class 2  
**TEMPERATURE** -10°C to 35°C  
**CONFORMITY** EMC-89/336/EEC   
 LVD-73/23/EEC

### IMPORTANT NOTICE!

This device should be installed by a qualified electrician in accordance with the latest edition of the IEE wiring regulations.

## Part Numbers

COMCTSRA Command Connect - Recessed PIR Presence Detector (Switching)



**Whitecroft Lighting Limited**  
 Burlington Street  
 Ashton-under-Lyne  
 Lancashire OL7 0AX  
 United Kingdom  
 Tel: + 44 (0) 870 5087 087  
 Fax: + 44 (0) 870 5084 210  
 www.whitecroftlighting.com  
 technical@whitecroftlight.com

## Installation Instructions



## COMCTSRA

### Recessed PIR Presence Detector (Switching)

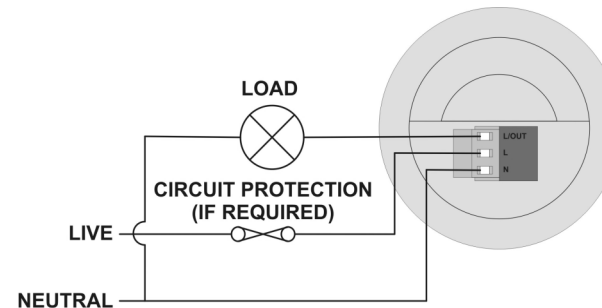
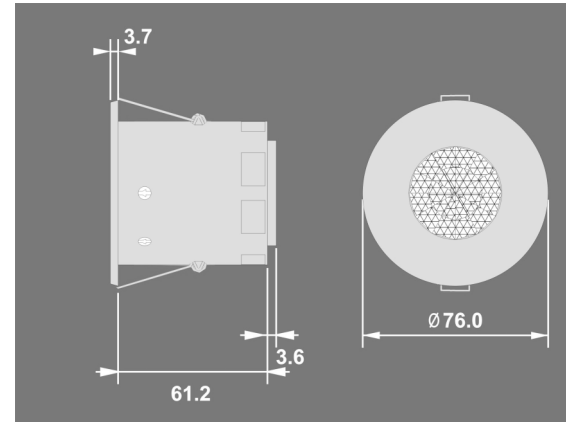

## Overview

The COMCTSRA presence detector is designed to provide automatic control of lighting, heating or ventilation loads. They detect movement using a PIR sensor and turn the load on. When an area is no longer occupied the load will switch off after an adjustable time out period.

An adjustable internal light sensor provides additional energy saving in lighting applications. When an area is occupied lighting is only switched on when the level of natural light is below a preset level.

When the unit is first powered up the PIR sensor will always detect immediately regardless of whether the room is occupied.

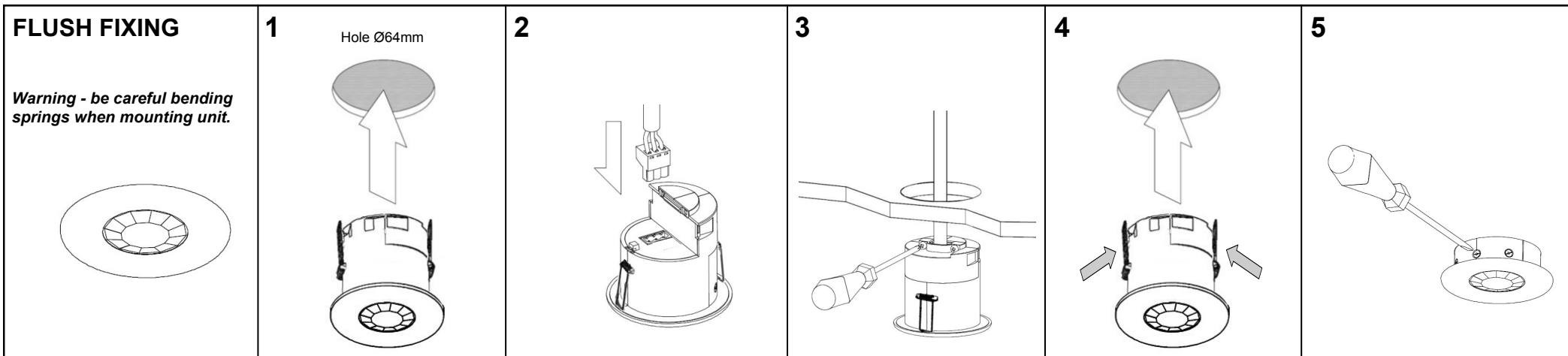

## Installation

- The detector should be sited so that the occupants of the room fall inside the detection pattern shown overleaf, at a recommended height of 2.8m on the ceiling. Note that the lower the sensor is installed the smaller the detection range will be, subject to the parameters shown on the diagram.
- Avoid direct sunlight entering the sensor.
- Do not site within 1m of forced air heating or ventilation.
- Do not site within 1m of any lighting.
- Do not fix to a vibrating surface.
- Wire the product using the connector using the diagram on the front page.
- Mount using one of the two options above.
- To switch from more than one position simply wire two or more units in parallel.
- Set the LUX level to maximum and the time to minimum.
- Power the unit up—the load should come on immediately.
- Vacate the room or remain very still and wait for the load to switch off (should take no more than 2 minutes).
- Check that the load switches on when movement is detected.
- To set the final LUX level wait until the level of natural daylight is just enough that lighting is required. Starting with the LUX control fully clockwise (at minimum), very slowly turn the control anti-clockwise until the lights come on. Note that when the LUX control is at maximum then the lights will **always** come on with occupancy.
- Set the time required.

## Fault Finding

### LOAD DOES NOT COME ON

Check to see if the live supply to the circuit is good. Strap across the *L* and *LIVE OUT* terminal to turn the load on.

If the supply and wiring are good, check the LUX level setting. Increase the LUX level setting to allow the controller to turn on at higher ambient natural light level.

If the detection range is smaller than expected, check the diagram above. Rotating the sensor slightly may improve the range.

### LIGHTS DO NOT GO OFF

Ensure that the area is left unoccupied for longer than the selected timer setting.

Make sure that the sensor is not adjacent to circulating air, heaters or lamps.