

Fixed Blade Swirl Diffusers

- SDTA** Square plate straight pattern swirl diffuser
- SDTB** Square plate curved pattern swirl diffuser
- SDCA** Circular plate straight pattern swirl diffuser
- SDCB** Circular plate curved pattern swirl diffuser



SDCB



SDTA

Fixed Blade Swirl Diffusers

SDT / SDC

Introduction

The SDT / SDC Fixed Blade Swirl Diffuser present an attractive alternative to the existing range. These diffusers produce a horizontal radial air pattern with high induction effect, making them ideally suited for applications with high heating and cooling differentials. Manufactured from sheet steel with press formed blades, the units are available in four standard sizes with either 24 straight (SDTA/SDCA) or 24 curved blades (SDTB/SDCB).

Product Description

- SDTA** Square plate straight pattern swirl diffuser
- SDTB** Square plate curved pattern swirl diffuser
- SDCA** Circular plate straight pattern swirl diffuser
- SDCB** Circular plate curved pattern swirl diffuser
- DM** Duct collar
- WTP** Side entry plenum box
- FDC1** Cord operated flap damper
- FDQ1** Quadrant operated flap damper
- LINED** 6mm acoustic lining (optional) reaction to fire class C-s3-d0 to EN 13501-1: 2007

Please note the duct collar is not required when ordering diffusers with plenums.

Sizes

See table

Finishes

- PPG9010 (RAL 9010 Gloss - 80% Gloss White)
- PPM9010 (RAL 9010 Matt - 20% Gloss White)
- PPM9006 (RAL 9006 Matt - 30% Gloss Silver)
- Other colours available on request

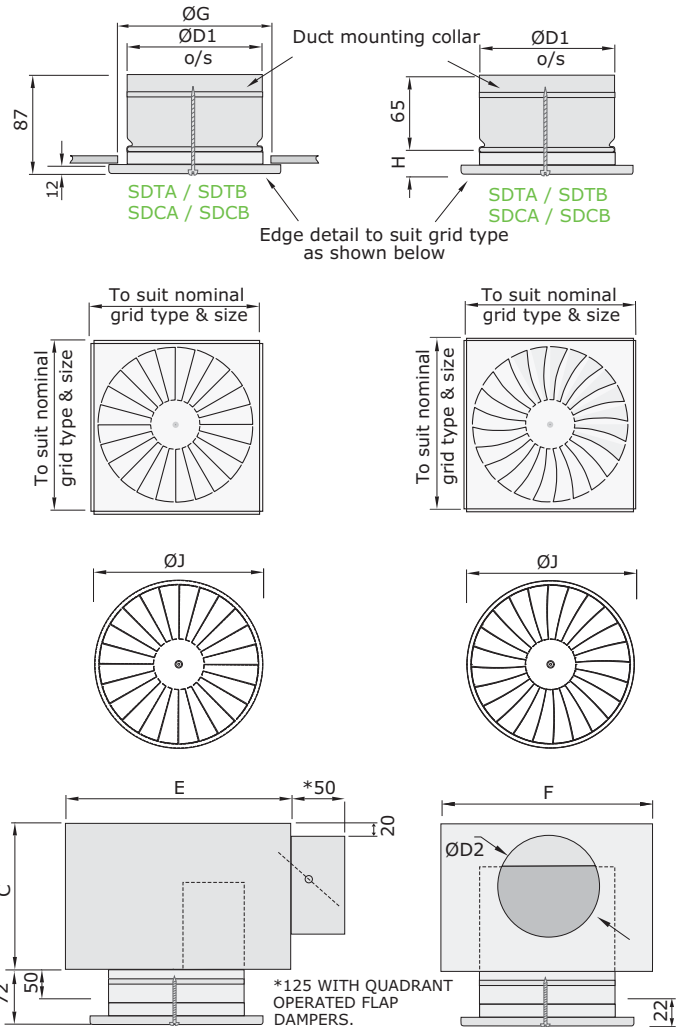

SDTA - SDTB Frame Styles and Grid Sizes

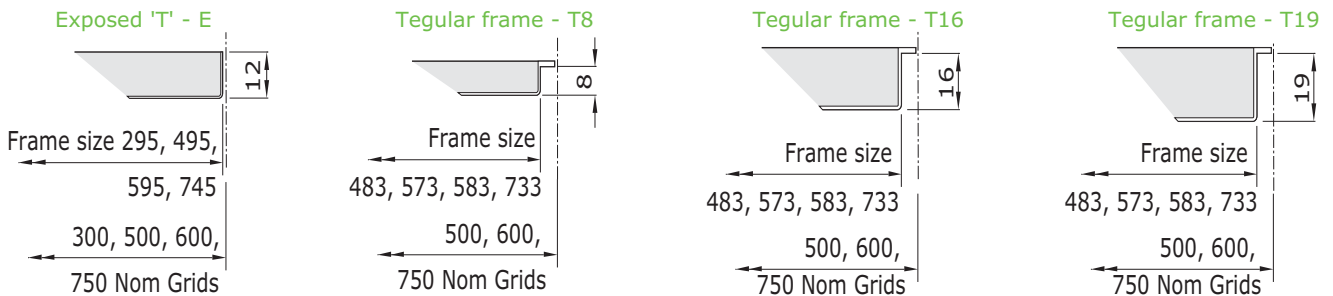

ORDER EXAMPLE

SDTA/250/500/T8/483/DM/9010-Matt

Type _____

Nominal size _____

Grid size _____

Frame style _____

Frame size _____

Duct collar _____

Finish _____

Please note: For plenum order example see page 4.

Weights

SDT / SDC	Diffuser + Collar	Plenum
250 Ø	3.7 kg	5.1 kg
350 Ø	3.9 kg	7.7 kg
450 Ø	4.0 kg	10.2 kg
550 Ø	4.2 kg	12.4 kg

Fixed Blade Swirl Diffusers

SDT / SDC

Selection Criteria

Throw data is expressed in metres and is based on a terminal velocity of 0.5 m/s at 10°C cooling differential. For isothermal conditions apply a factor of 1.15 to the throws. For 10°C heating apply a factor of 1.32.

Noise levels are sound power levels with an assumed 8 dB room attenuation expressed in dBA. Pressure loss data is shown for a WTP plenum mounted diffuser.

Selection Example

SDTA/350, SDTB/350
SDCA/350, SDCB/350

Air flow rate 60 l/s

SDTA / SDCA Diffuser

Throw 2.2m
Static Pressure Loss 18 Pa
Noise level 21 dBA

SDTB / SDCB Diffuser

Throw 2.2m
Static Pressure Loss 15 Pa
Noise level 20 dBA

Sizes

Nominal Size	Available Grid Sizes	Plenum Width ' F '	Plenum Length ' E '	Plenum Height ' C '	Spigot size ØD2	Duct collar ØD1	Ceiling opening ØG	H	J
250	300, 500, 600 or 750	400	400	260	200	248	260	22	270
350	500, 600 or 750	500	500	310	250	343	360	22	370
450	500, 600 or 750	560	560	375	315	443	460	22	470
550	600 or 750	650	650	375	315	543	560	22	580

Performance Table

SDT / SDC			Supply Air Volume (l/s)								
Diameter	Type	Parameter	25	30	40	60	80	100	125	150	175
250	A & B	Throw (m)	0.8	1.4	2.2						
	A	L _{WA} (dBA)	<20	21	24						
		Δp (Pa)	4	9	17						
	B	L _{WA} (dBA)	<20	20	23						
		Δp (Pa)	4	7	15						
350	A & B	Throw (m)		0.8	1.5	2.2	3.0				
	A	L _{WA} (dBA)		<20	<20	21	29				
		Δp (Pa)		4	9	18	27				
	B	L _{WA} (dBA)		<20	<20	20	24				
		Δp (Pa)		4	6	15	25				
450	A & B	Throw (m)				1.6	2.4	3.1	3.6		
	A	L _{WA} (dBA)				<20	23	30	36		
		Δp (Pa)				10	14	23	41		
	B	L _{WA} (dBA)				<20	22	25	28		
		Δp (Pa)				8	11	21	36		
550	A & B	Throw (m)				0.6	1.5	2.3	3.0	3.6	4.1
	A	L _{WA} (dBA)				<20	20	22	28	35	42
		Δp (Pa)				4	7	10	16	25	32
	B	L _{WA} (dBA)				<20	<20	22	23	24	26
		Δp (Pa)				4	5	7	13	22	29

Plenum Box to suit Swirl Diffusers

WTP

Introduction

Plenum boxes for our SDF swirl diffusers are designed to guarantee a good mixing of the air prior to diffusion through the terminals. Available with Side or Top Entry connections to customer-specific diameters, these can be fitted with Spigot Flap Dampers, cord- / quadrant-operated, as well as 6mm acoustic lining (optional) reaction to fire class C-s3-d0 to EN 13501-1: 2007 to avoid noise generation. The Supply air plenum box includes an internal baffle plate to evenly distribute the airflow over the swirl area.

Product Description

- WTP** Plenum box to suit SDF Fixed Blade Swirl Diffusers
- SE** Side Entry spigot
- TE** Top Entry spigot
- FDC** Cord-operated Flap Damper (optional)
- FDQ** Quadrant-operated Flap Damper (optional)
- LINED** 6mm acoustic lining (optional) reaction to fire class C-s3-d0 to EN 13501-1: 2007
- BLACK** Plenum painted black to prevent through vision (optional)

Features

- Galvanised steel, stitch fixed
- Side Entry spigot with optional airflow control damper
- Oblong holes on top plate for easy drop rod installation
- Internal baffle plate for Supply air diffuser

Finish

- WTP** Galvanised sheet steel

Note: The connection between the diffuser and plenum is adequately sealed for most installations, although secondary additional sealing may be required at the discretion of the installers, if the leakage rate required is particularly low.

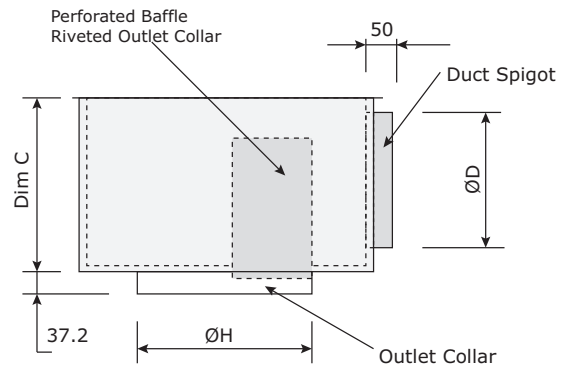
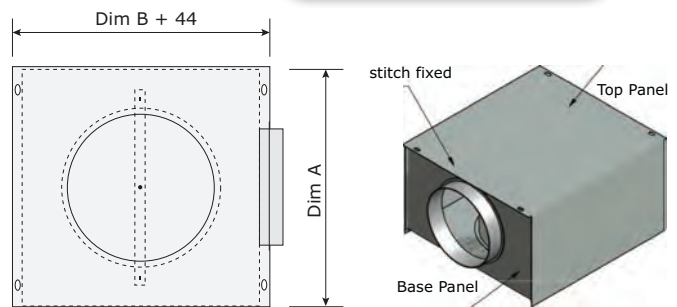
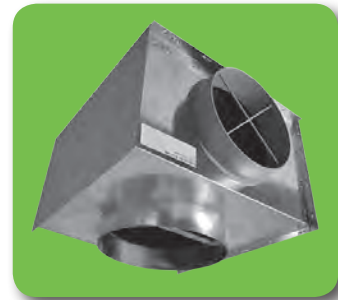

Dimensions

Nominal Collar Size	Where Used	Plenum Width 'A'	Plenum Width 'B'	Plenum Width 'C'	Spigot Size ØD	Outlet Collar ØE	Baffle Height 'F'	Baffle Length 'G'	Duct Collar ØH	Baffle Radius 'R'	Mounting Bar Hole Ctrs 'J'	Mounting Bar Length 'K'
Ø125	SDF Series	300	300	160	100	125	100	175	123	62	185	225
Ø160	SDF Series	300	300	185	125	160	140	230	158	80	220	260
Ø200	SDF Series	400	400	220	160	200	165	285	198	100	260	300
Ø250	SDF & SDT Series	400	400	260	200	250	205	365	248	125	310	350
Ø315	SDF Series	500	500	310	250	315	245	465	313	157	375	415
Ø350	SDT Series	500	500	310	250	345	245	514	343	172	375	395
Ø400	SDF Series	560	560	375	315	400	310	600	398	200	460	500
Ø450	SDT Series	560	560	375	315	445	310	664	443	222	500	545
Ø550	SDT Series	650	650	375	315	545	310	814	543	272	600	645

ORDER EXAMPLE

WTP-200/SE/1CC/197dia/FDC/Lined 19mm/BFL

Type _____

Size _____

Spigot position _____

Spigot type _____

Spigot size _____

Spigot damper _____

Acoustic lining _____

Baffle _____

FD Spigot Control Dampers

Introduction

Designed as a cost-effective, efficient way to adjust the airflow supplied through plenum boxes or neck reducers, the FD Flap Dampers can be fitted to any of our spigots - circular, rectangular or flat oval.

They can be adjusted with a cord, fed through the air terminal device and ready for commissioning, or with an external quadrant accessible from outside the duct, allowing for the damper to be locked into position.

Product Description

FDC Flap Spigot Damper, Cord operated

FDQ Flap Spigot Damper, Quadrant operated

Features

- Cost-effective airflow regulation
- Suitable for any size / shape spigot
- Choice of adjustment devices – Cord for commissioning flexibility or Quadrant for position control

Finish

FD Aluminium blades

Dimensions

Any, to match spigot sizes

Note – the FD can only be selected with the relevant Plenum Box or Neck Reducer and trimming damper not suitable for use with a spigot velocity greater than 3.0m/s

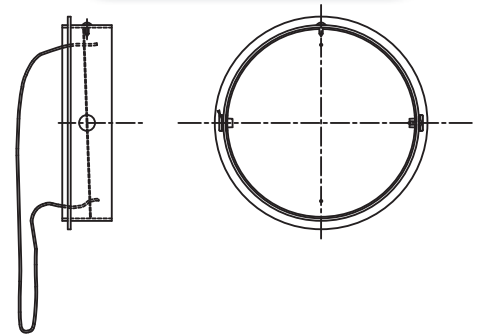
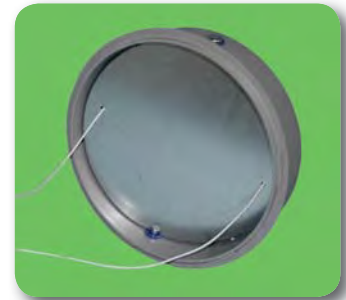

ORDER EXAMPLE

PBD-DF/200/200/260/SE/1CC/157dia/FDC/Lined

Type _____

Plenum box length _____

Plenum box width _____

Plenum box height _____

Spigot position _____

Spigot type _____

Spigot size _____

Spigot damper _____

Acoustic lining _____

PB / NR Spigot Selection Sheet

Circular Ductwork / Spigots										
Duct Size	Spigot Size	Velocity Per Spigot (m/s)							Spigot Area	Spigot Circumference
		3	2.75	2.5	2.25	2	1.75	1.5		
mm	mm	Air Flow Rate Per Spigot (l/s)							m ²	mm
75	72	12	11	10	9	8	7	6	0.0041	226
100	97	22	20	18	17	15	13	11	0.0074	305
125	122	35	32	29	26	23	20	18	0.0117	383
150	147	51	47	42	38	34	30	25	0.0170	462
160	157	58	53	48	44	39	34	29	0.0194	493
175	172	70	64	58	52	46	41	35	0.0232	540
180	177	74	68	62	55	49	43	37	0.0246	556
200	197	91	84	76	69	61	53	46	0.0305	619
225	222	116	106	97	87	77	68	58	0.0387	697
250	247	144	132	120	108	96	84	72	0.0479	776
275	272	174	160	145	131	116	102	87	0.0581	855
300	297	208	191	173	156	139	121	104	0.0693	933
315	312	229	210	191	172	153	134	115	0.0765	980
325	322	244	224	204	183	163	143	122	0.0814	1,012
350	347	284	260	237	213	189	166	142	0.0946	1,090
375	372	326	299	272	245	217	190	163	0.1087	1,169
400	397	372	341	310	279	248	217	186	0.1238	1,247
425	422	420	385	350	315	280	245	210	0.1399	1,326
450	447	471	432	392	353	314	275	235	0.1569	1,404
475	472	525	481	438	394	350	306	263	0.1750	1,483
500	497	582	534	485	437	388	340	291	0.1940	1.561

PB / NR Spigot Selection Sheet

Flat Oval Spigots / Based on Area										
Duct Size	Spigot Size	Velocity Per Spigot (m/s)							Spigot Area	Spigot Circumference
		3	2.75	2.5	2.25	2	1.75	1.5		
mm	mm	Air Flow Rate Per Spigot (l/s)							m ²	mm
100 x 50	97 x 47	12	11	10	9	8	7	6	0.0041	248
170 x 50	167 x 47	22	20	18	17	15	13	11	0.0074	388
181 x 75	178 x 72	35	32	29	26	23	20	18	0.0117	438
255 x 75	252 x 72	51	47	43	38	34	30	26	0.0170	586
287 x 75	284 x 72	58	53	48	44	39	34	29	0.0193	650
264 x 100	261 x 97	70	64	58	52	47	41	35	0.0233	633
278 x 100	275 x 97	74	68	62	55	49	43	37	0.0247	661
338 x 100	335 x 97	91	84	76	69	61	53	46	0.0305	781
347 x 125	344 x 122	116	107	97	87	78	68	58	0.0388	827
422 x 125	419 x 122	144	132	120	108	96	84	72	0.0479	977
430 x 150	427 x 147	174	160	145	131	116	102	87	0.0581	1,022
506 x 150	503 x 147	208	191	173	156	139	121	104	0.0693	1,174
476 x 175	473 x 172	225	206	188	169	150	131	113	0.0750	1,142
514 x 175	511 x 172	245	224	204	183	163	143	122	0.0815	1,218
526 x 200	523 x 197	284	260	237	213	189	166	142	0.0947	1,271
597 x 200	594 x 197	326	299	272	245	217	190	163	0.1087	1,413
674 x 200	671 x 197	372	341	310	279	248	217	186	0.1239	1,567
681 x 200	678 x 222	420	385	350	315	280	245	210	0.1399	1,609
692 x 250	689 x 247	471	432	393	353	314	275	236	0.1571	1,660
765 x 250	762 x 247	525	482	438	394	350	306	263	0.1751	1,806
775 x 275	772 x 272	582	534	485	437	388	340	291	0.1941	1,855

Flat Oval Spigots / Spigot Circumference										
Duct Size	Spigot Size	Velocity Per Spigot (m/s)							Spigot Area	Spigot Circumference
		3	2.75	2.5	2.25	2	1.75	1.5		
mm	mm	Air Flow Rate Per Spigot (l/s)							m ²	mm
89 x 50	86 x 47	11	10	9	8	7	6	5	0.0036	226
129 x 50	126 x 47	16	15	14	12	11	10	8	0.0054	306
154 x 75	151 x 72	29	27	24	22	20	17	15	0.0098	384
193 x 75	190 x 72	38	35	31	28	25	22	19	0.0126	462
209 x 75	209 x 72	41	38	34	31	27	24	21	0.0137	494
218 x 100	215 x 97	57	52	47	42	38	33	28	0.0188	541
226 x 100	223 x 97	59	54	49	44	39	34	29	0.0196	557
257 x 100	254 x 97	68	62	57	51	45	40	34	0.0226	619
282 x 125	279 x 122	93	85	77	69	62	54	46	0.0308	697
321 x 125	318 x 122	107	98	89	80	71	62	53	0.0356	775
346 x 150	343 x 147	137	126	114	103	92	80	69	0.0458	854
386 x 150	383 x 147	155	142	129	116	103	90	78	0.0517	934
395 x 175	392 x 172	183	168	153	137	122	107	92	0.0611	980
411 x 175	408 x 172	192	176	160	144	128	112	96	0.0638	1,012
436 x 200	433 x 197	231	212	192	173	154	135	115	0.0770	1,091
475 x 200	472 x 197	254	233	212	191	169	148	127	0.0847	1,169
514 x 200	511 x 197	277	254	231	208	185	162	139	0.0923	1,247
539 x 200	536 x 222	325	298	271	244	217	190	163	0.1084	1,325
564 x 250	561 x 247	376	345	314	282	251	220	188	0.1255	1,404
603 x 250	600 x 247	405	372	338	304	270	236	203	0.1351	1,482
628 x 275	625 x 272	462	424	385	347	308	270	231	0.1541	1,561

Waterloo Product Range

GRILLES

A complete range of products suitable for all wall, ceiling and floor applications. Most grilles are made from aluminium and have a range of fixed or moveable blades designed to give performance whilst remaining aesthetically pleasing to the eye. Grilles are made to customer specified sizes and colours (PPM/G); standard colour PPM9010 (20% Gloss White). The range is complemented by the Aircell range of polymer Grilles.



DIFFUSERS

Designed to be installed in various ceiling systems, we have a complete range to suit both performance and aesthetical requirements. Most diffusers are made from aluminium and can be ordered with or without plenum boxes for easy duct work. Diffusers can be ordered in customer specified colours (PPM/G); standard colour is PPM 9010 (20% Gloss White). This range is complemented by the Aircell range of polymer Diffusers.



ACTIVE AND PASSIVE CHILLED BEAMS

The finest quality range of high output active beams, used for ventilated heating and cooling applications. These units have 4 pipe coils to allow heating and cooling circuits to run simultaneously, giving constant and responsive control. The design allows a large optimum capacity and also allows the customer to specify the nozzle type and pitch for individual circumstances.

Active beams are made from steel to a large range of customer specified sizes and as such are suitable for various different ceiling systems. Standard finish is PPM 9010, however other (PPM/G) colours are available on request.

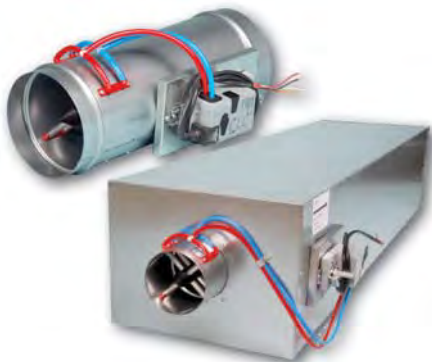

AIR VOLUME CONTROL DAMPERS

Pressure independent Variable Air Volume and Constant Air Volume dampers made from zintec plate. Most volume dampers are regulated with an electronic motor and sensors and are calibrated to customer specifications before delivery.

The Constant Air Volume damper requires no power source as it is controlled via a mechanical device and calibrated before delivery. All volume dampers can be ordered with a single or double (insulation) skin.

EXTERNAL LOUVRES

A quality range of products for external wall applications. Made from aluminium, with birdscreen or insect screen options. All louvres are made to customer specified sizes and (PPM/G) colours; standard colour is PPM 9006.



DISPLACEMENT

A full range of recessed, semi-recessed, floor, wall and corner units providing high ventilation efficiency and excellent comfort. The very low pressure involved also offer quiet installations. Displacement units are available as wall or floor mounted, or indeed integrated within the architectural design.



Waterloo Air Products Ltd

Head Office:

Mills Road, Aylesford,
Maidstone, Kent ME20 7NB
Tel: +44 (0)1622 711500
Fax: +44 (0)1622 710648
email: sales@waterloo.co.uk
internet: www.waterloo.co.uk

Northern Office:

Hyde Park House, Cartwright Street,
Newton, Hyde SK14 4EH
Tel: +44 (0)161 367 1264
Fax: +44 (0)161 367 1262
email: sales@waterloo.co.uk
internet: www.waterloo.co.uk



FM 27823



EMS 590755

All products conform to the Terms and Conditions of Waterloo Air Products Ltd a copy of which are available upon request. Due to our continuous research and development programme, Waterloo Air Products Ltd reserve the right to alter products and prices without prior notification.

Copyright Waterloo Air Products Ltd 2019

Waterloo declare that, at the time of print, all products are in accordance with relevant directives, as identified by HEVAC and other European Organisations and will display the CE Marking where required.