



Louvred Face Diffusers Plenum Chambers and Neck Reducers

Introduction

Correct selection and sizing of distribution plenum chambers and neck reducers is critical because terminal air resistance is very low relative to the distribution ductwork resistance. It is therefore recommended that whenever possible terminals are served by low velocity stub ducts from branch ducting systems fitted with correct balancing controls. Where it is necessary to specify and use plenums a generous allowance for commissioned noise generation should be made. A similar effect results from use of neck reducers with circular duct connections because the reduced duct area will cause generally higher velocities and hence increased risk of noise generation

Product Description

PBD Plenum chamber
NR-D Top entry neck reducer

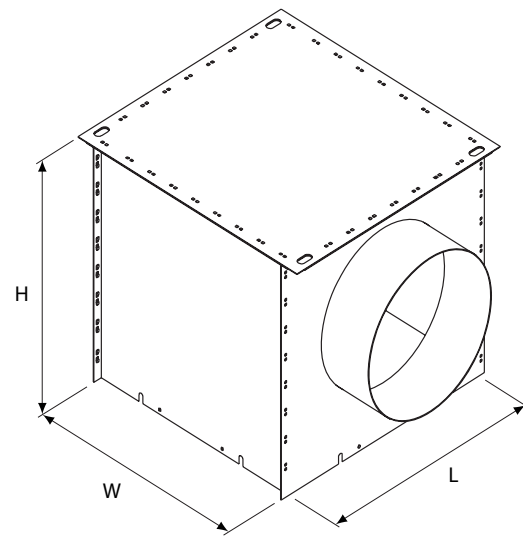

PBD Side entry plenum box

Features

- Plated steel with stitched seam joints.
- Plenums are available with circular, square or rectangular spigots in either top or side entry applications
- Neck reducers are available with circular, square or rectangular spigots in top entry only

Installation

The plenum boxes and neck reducers are supported by 4 drop rods through a locating hole positioned near each corner.

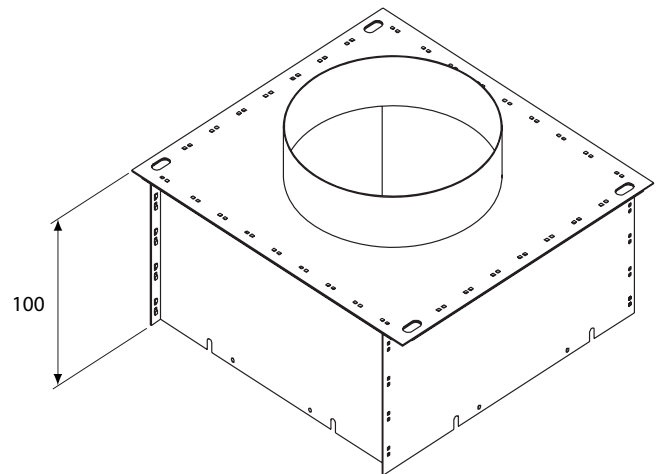

NR-D Neck reducer

When ordering plenum chambers please specify length width & height, spigot size and position (top or side entry) and control options. Please note that the plenum height should in general be 100mm greater than the spigot diameter (side entry applications).

Neck reducers are available as standard in sizes up to 1200 x 600. The high profile is designed to accommodate an opposed blade damper.

Plenum chambers

Pressure loss: multiply diffuser pressure loss by 1.25
NR level: based on peak sound power level less 8dB room absorption allowance
Note: Actual spigot size = nominal - 3mm

Neck reducers

Pressure loss and noise levels should be based on the spigot air velocity and the nominal diffuser size, ie. if a 450 sq neck diffuser handling 200 l/s is fitted with a neck reducer having a 315 Ø spigot, the inlet air velocity is approximately 2.5 m/s. Referring to the selection tables, at the equivalent air velocity through the diffuser neck the noise level would be NC33 and the pressure loss 23Pa.

Throw: use catalogue data providing that the ratio of diffuser to neck size remains less than 1.5:1.

Diffuser Neck Size (mm)	Nominal Spigot Size (mm)	Diffuser + Plenum + Open OBSS Maximum flow rate to achieve stated noise levels (l/s)					Actual Plenum Dimensions		
		NR25	NR30	NR35	NR40	NR45	L	W	H
150x150	150Ø	45	55	65	80	95	150	150	250
225x225	200Ø	75	100	125	150	175	225	225	300
225x150	200Ø	60	80	100	115	130	225	150	300
300x300	250Ø	140	170	210	260	310	300	300	350
300x225	250Ø	90	130	170	210	240	300	225	350
300x150	250Ø	85	110	135	160	185	300	150	350
375x375	350Ø	210	240	290	355	430	375	375	450
375x300	350Ø	160	210	260	330	400	375	300	450
375x225	350Ø	125	170	215	270	330	375	225	450
375x150	350Ø	120	140	170	210	260	375	150	450
450x450	400Ø	230	310	400	500	650	450	450	500
450x375	400Ø	220	280	355	450	590	450	375	500
450x300	400Ø	190	260	330	410	490	450	300	500
525x525	500Ø	290	410	540	670	840	525	525	600
525x450	500Ø	280	380	490	610	810	525	450	600
525x375	500Ø	275	360	460	580	690	525	375	600
525x300	500Ø	235	315	380	480	590	525	300	600
600x600	500Ø	530	620	700	850	1020	600	600	600
600x450	500Ø	380	450	540	660	850	600	450	600
600x300	500Ø	350	410	460	560	680	600	300	600