

# CS Linear Slot Diffusers

- CS-F Standard 28mm flange for general purpose
- CS-P Narrow 18mm flange for flush / recess mounting
- CS-J Medium 25mm flange for general purpose
- CS-M For Tegular 30mm, 16mm & 8mm drop fitting
- CS-S&E Supply and Exhaust (or dual supply) system diffuser
- CS-TW Extra wide flange
- CS Plank Plank replacement unit

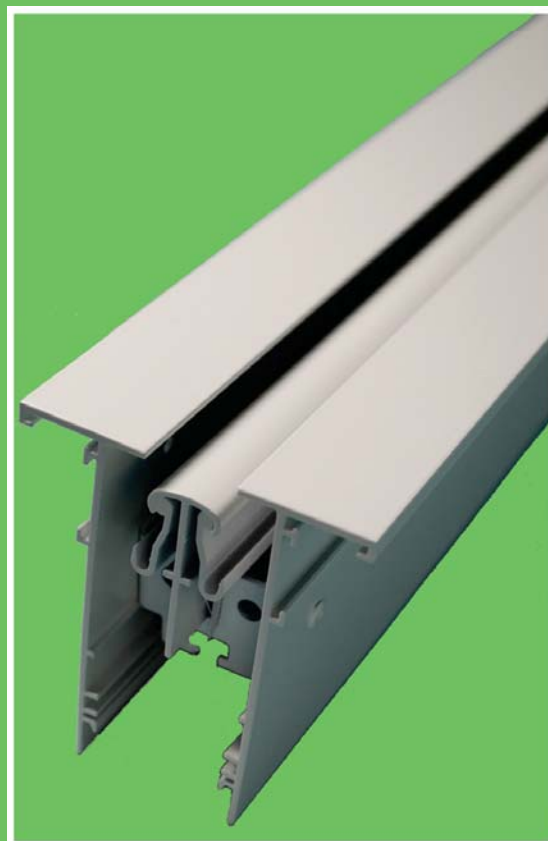



## Linear Slot Diffusers

CS-F / CS-P / CS-J / CS-M / CS-S&E / CS-TW / CS Plank

### Introduction

The Waterloo Small Format Continuous Slot Diffuser series (CS), has for many years set the industry standard in terms of highest aerodynamic and acoustic performance. The CS range is ideally suited to variable volume applications due to its excellent low flow rate air diffusion characteristics and high air handling capacity. The novel air pattern control element design allows any air diffusion to vertical projection, without any change in the facial appearance.

CS diffusers are suitable for all commercial and industrial projects requiring single or multi-slot diffusers for ceilings, bulkheads or sidewall supply and exhaust.

Diffusers are manufactured from aluminium alloy extrusions fixed or clipped to cross stays allowing easy removal of internal vanes and pattern control elements.

### Product Description

- CS-F** Standard 28mm flange for general purpose
- CS-P** Narrow 18mm flange for flush / recess mounting
- CS-J** Medium 25mm flange for general purpose
- CS-M** For Regular 30mm, 16mm & 8mm drop fitting
- CS-S&E** Supply and Exhaust (or dual supply) system diffuser
- CS-TW** Extra wide flange
- CS Plank** Plank replacement unit (Refer to Head Office for details)
- Ends** Standard end caps
- MEC** Mitred end caps
- BP** Blanking plate - supplied loose in 1250 lengths (for fitting on site by others)
- ED** Equalising deflector

### Features

- High air capacity
- Wide dynamic range perfect for VAV systems
- Strong coanda effects for good low flow performance
- Fully adjustable air pattern from horizontal to vertical
- Hidden flow control vanes for consistent facial appearance
- Continuous joint detail for ceiling integrations

### Finishes

PPG9010 (RAL 9010 Gloss - 80% Gloss White)  
 PPM9010 (RAL 9010 Matt - 20% Gloss White)  
 PPM9006 (RAL 9006 Matt - 30% Gloss Silver)  
 Other colours available on request  
 Pattern control elements are supplied with the same finish as the frame (standard) but can be supplied in black.

### Sizes

Standard from 1 to 8 slots wide in 1500mm long sections (excluding flanged ends).

Continuous diffuser lengths are supplied in sections for butt jointing on site. (Alignment plates supplied)

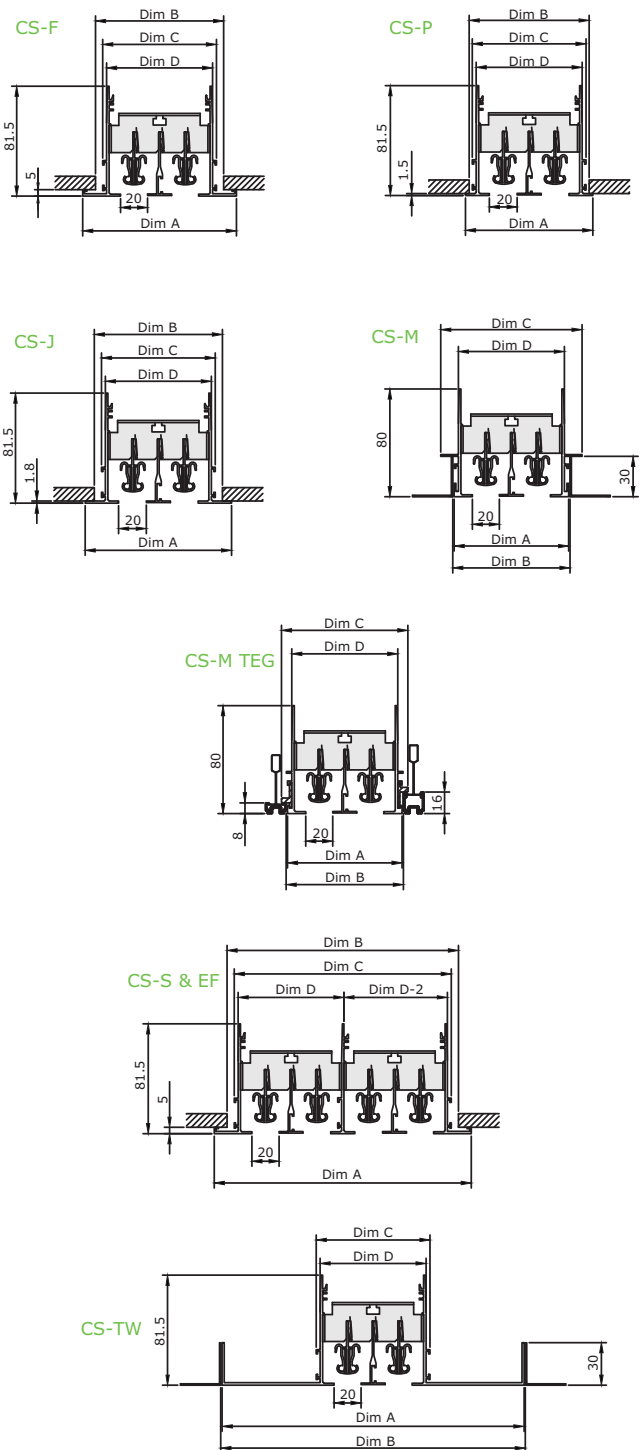

**ORDER EXAMPLE**

CS-F/3000/S1/PPM9010/ENDS

Type \_\_\_\_\_

Length \_\_\_\_\_

No of Slots \_\_\_\_\_

Finish \_\_\_\_\_

Ends caps \_\_\_\_\_

Style	Weights kg/m							
	No of slots							
	1	2	3	4	5	6	7	8
CS-F	1.9	2.7	3.5	4.3	5.1	5.9	6.7	7.5
CS-P	1.8	2.6	3.4	4.2	5.0	5.8	6.6	7.4
CS-J	1.9	2.7	3.5	4.3	5.1	5.9	6.7	7.5
CS-M	1.8	2.6	3.4	4.2	5.0	5.8	6.6	7.4
CSM -TEG	1.8	2.6	3.4	4.2	5.0	5.8	6.6	7.4
CS-S & E-F	2.0	2.8	3.6	4.4	5.2	6.0	6.8	7.6
CS-TW	2.6	3.4	4.2	5.0	5.8	6.6	7.4	8.2



## Linear Slot Diffusers

CS-F / CS-P / CS-J / CS-M / CS-S&E / CS-TW / CS Plank

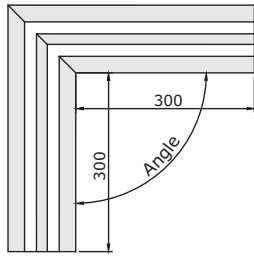

Standard CS Mitred Corner

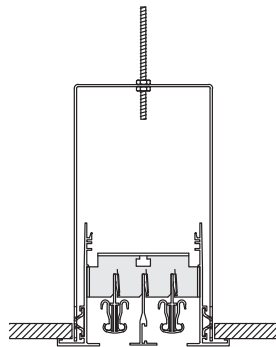

Dummy hanging bracket fixing available for 1 to 8 slot

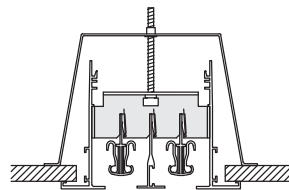

Plasterboard bracket fixing available for 1 to 6 slot

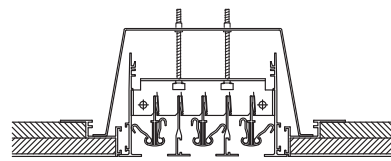

CSP Plaster Frame

	Type PB	Type PLS
Slots	Dim E	Dim F
1 Slot	46	34
2 Slot	84	72
3 Slot	122	110
4 Slot	160	148
5 Slot	198	186
6 Slot	236	225
7 Slot	274	263
8 Slot	312	301

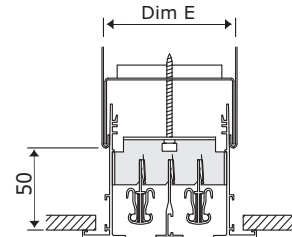

Standard plenum mounting Type PB

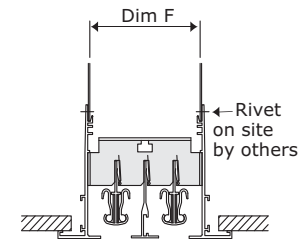

Riveted plenum mounting Type PLS (Access required both sides)

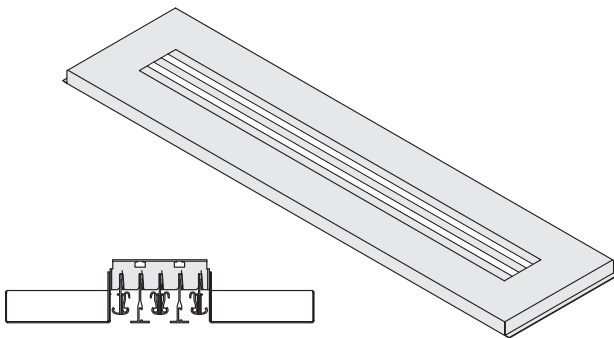

CS Plank (Typical size is 1200 x 150 with internal 2 slot or 1200 x 300 with internal 3/4 slot)

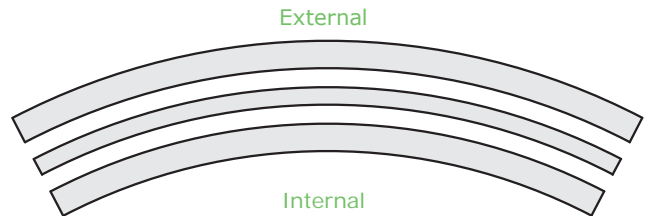

Internal, external or vertical air throw available, please specify on order.

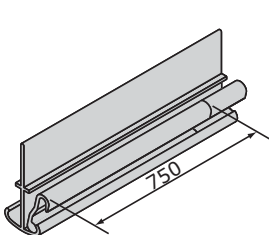

**Standard**  
Diffusers are supplied with flow control vanes in lengths up to 750mm (to suit diffuser length).

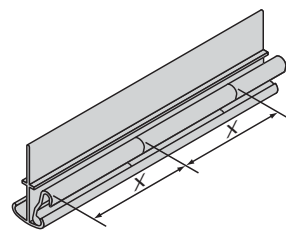

**Special**  
To provide finer control of the air pattern, flow control vanes may be supplied in any specified length.

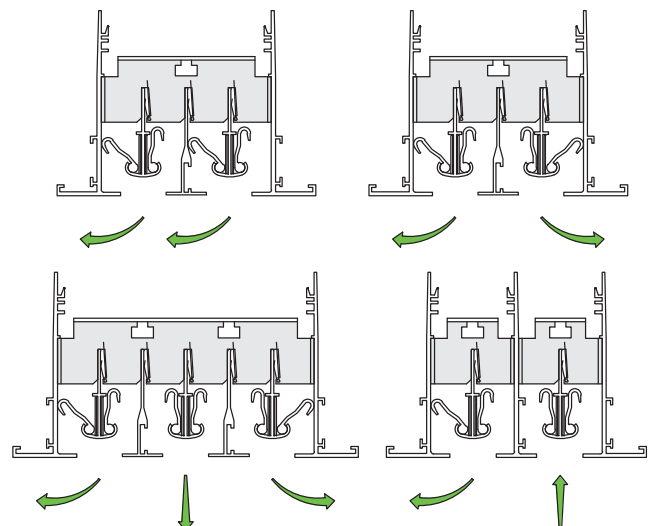

Typical PCE Settings



## Linear Slot Diffusers

CS-F / CS-P / CS-J / CS-M / CS-S&E / CS-TW / CS Plank

Diffuser Type	Dimension Reference	No of slots							
		1	2	3	4	5	6	7	8
CS-F	Dim A = O/A Face Flange Width	76	114	152	190	228	266	304	343
	Dim B = Ceiling Cutout Width	57	95	133	171	209	247	285	324
	Dim C = O/A Stack Width	45	84	122	160	198	236	274	312
	Dim D = Outside Stack Width	40	79	117	155	193	231	269	307
CS-P	Dim A = O/A Face Flange Width	56	95	133	171	209	247	285	323
	Dim B = Ceiling Cutout Width	50	89	127	165	203	241	279	317
	Dim C = O/A Stack Width	45	84	122	160	198	236	274	312
	Dim D = Outside Stack Width	40	79	117	155	193	231	269	307
CS-J	Dim A = O/A Face Flange Width	70	108	146	184	222	260	298	337
	Dim B = Ceiling Cutout Width	57	95	133	171	209	247	285	324
	Dim C = O/A Stack Width	45	84	122	160	198	236	274	312
	Dim D = Outside Stack Width	40	79	117	155	193	231	269	307
CS-M	Dim A = O/A Face Flange Width	46	84	122	160	198	236	274	313
	Dim B = Ceiling Cutout Width	48	86	124	162	200	238	276	315
	Dim C = O/A Stack Width	67	105	143	181	219	257	295	334
	Dim D = Outside Stack Width	40	79	117	155	193	231	269	307
CS-M TEG	Dim A = O/A Face Flange Width	46	84	122	160	198	236	274	313
	Dim B = Ceiling Cutout Width	48	86	124	162	200	238	276	315
	Dim C = O/A Fitting Lug Width	56	94	132	170	208	246	284	323
	Dim D = Outside Stack Width	40	79	117	155	193	231	269	307
CS-S & E-F	Dim A = O/A Face Flange Width	-	114	152	190	228	266	304	343
	Dim B = Ceiling Cutout Width	-	95	133	171	209	247	285	324
	Dim C = O/A Stack Width	40	79	117	155	193	231	269	-
	Dim D = Outside Stack Width	-	84	122	160	198	236	274	312
CS-TW	Dim A = O/A Face Flange Width	184	223	261	299	337	375	413	451
	Dim B = Ceiling Cutout Width	185	224	262	300	338	376	414	452
	Dim C = O/A Stack Width	45	84	122	160	198	236	274	312
	Dim D = Outside Stack Width	40	79	117	155	193	231	269	307



## Linear Slot Diffusers

CS-F / CS-P / CS-J / CS-M / CS-S&E / CS-TW / CS Plank

FLAT END CAPS			
Diffuser Style	Dim L1	Dim L2	Dim L3
CS-M	Nominal Length	Nominal Length - 6	Nominal Length + 2
CS-M TEG	Nominal Length	Nominal Length - 6	Nominal Length + 2

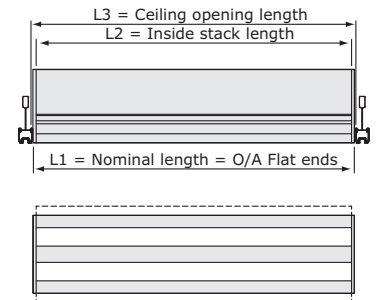

STANDARD END CAPS				
Diffuser Style	Dim L1	Dim L2	Dim L3	Dim L4
CS-F	Nominal Length	Nominal Length + 3	Nominal Length + 19	Nominal Length + 56
CS-P	Nominal Length	Nominal Length + 3	Nominal Length + 19	Nominal Length + 36
CS-J	Nominal Length	Nominal Length + 3	Nominal Length + 19	Nominal Length + 53
CS-S & E-F	Nominal Length	Nominal Length + 3	Nominal Length + 19	Nominal Length + 56
CSM	Nominal Length	Nominal Length + 6	Nominal Length + 2	Nominal Length + 6

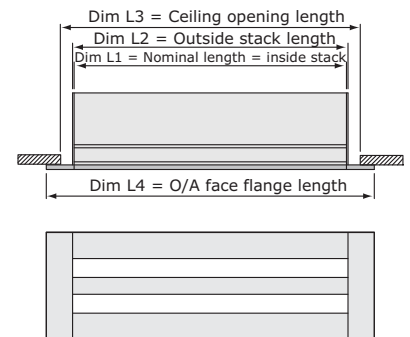

MITRED END CAPS				
Diffuser Style	Dim L1	Dim L2	Dim L3	Dim L4
CS-F	Nominal Length	Nominal Length - 39	Nominal Length - 30	Nominal Length - 19
CS-P	Nominal Length	Nominal Length - 20	Nominal Length - 11	Nominal Length - 7
CS-J	Nominal Length	Nominal Length - 33	Nominal Length - 24	Nominal Length - 12
CS-S & E-F	Nominal Length	Nominal Length - 39	Nominal Length - 30	Nominal Length - 19

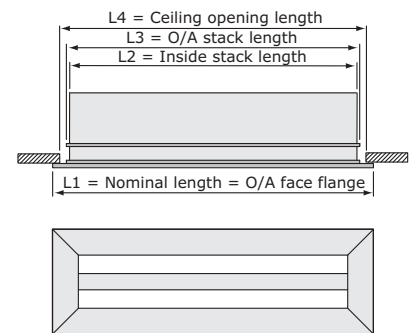

FLAT END CAPS				
Diffuser Style	Dim L1	Dim L2	Dim L3	Dim L4
CS-TW	Nominal Length	Nominal Length - 6	Nominal Length + 25	Nominal Length + 2

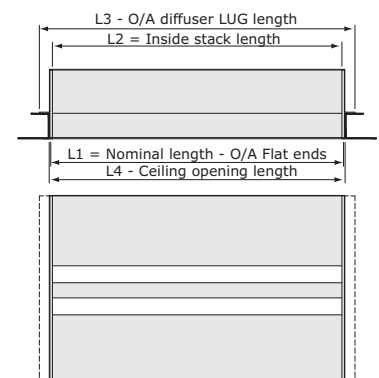



## Linear Slot Diffusers

CS-F / CS-P / CS-J / CS-M / CS-S&E / CS-TW / CS Plank

### Selection Criteria

Ceiling height 2.75m, increase throw by 1m for each 1m increase in ceiling height. Horizontal diffusion is based on a cooling differential of 11°C.

For isothermal diffusion apply a factor of 1.1 to throw values.

For heating in horizontal diffusion apply a factor of 1.2 to throw values.

Vertical projection is based on a heating differential of 11°C. Noise level is based on diffuser sound power level less 8dB room absorption.

$V_r$  = mean room air velocity (m/s)

$V_t$  = terminal velocity of supply air jet (m/s)

### Selection Example CS2/1800

Total air flow rate 180 l/s = 100 l/s/m

#### 1 Way Throw

Minimum throw 2.8m (3.5 x 0.8 factor) Maximum throw 7.2m (9.0 x 0.8 factor) Pressure drop 25Pa  
Noise level 34dBA (37dBA - 3dB length correction)

#### 2 Way Throw

Minimum throw 2.0m (2.5 x 0.8 factor) Maximum throw 5.2m (6.5 x 0.8 factor) Pressure drop 25Pa  
Noise level 30dBA (33dBA - 3dB length correction)

Length corrections					
Active Length (m)	0.5	1.25	2.0	2.5	3.0
dBA Reduction	-8	-5	-3	-2	0
Throw multiplier	0.45	0.65	0.8	0.9	1.0

### Performance Nomogram

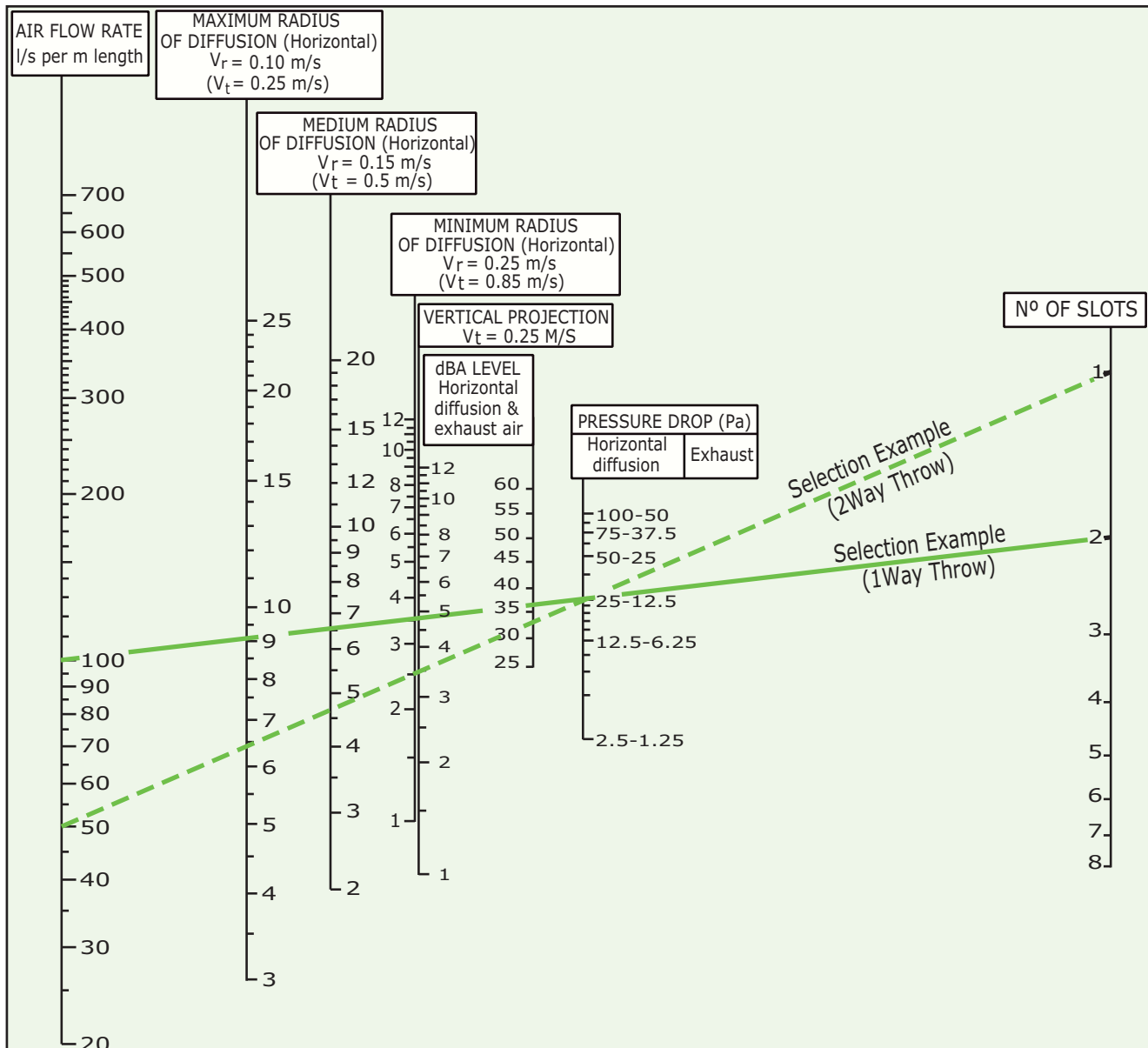



## Plenum Boxes

### Introduction

Our High- / Low- Line plenum boxes are designed to guarantee a good distribution of the air prior to diffusion through the terminals. Available with Side or Top Entry connections to customer-specific diameter/shape, these can be fitted with Spigot Flap Dampers, cord- / quadrant-operated, as well as 6mm acoustic lining (optional) reaction to fire class C-s3-d0 to EN 13501-1: 2007 to avoid noise generation. Also available with rivet fix (hem fix as standard).

### Product Description

- PBHL** High-Line Plenum box to suit CS / LCS / DSL / HF Linear Slot Diffusers
- PBLL** Low-Line Plenum box to suit CS / LCS / DSL / HF Linear Slot Diffusers
- PBHLB** High-Line Plenum box to suit CSB Barrel Slot Diffusers
- PBLLB** Low-Line Plenum box to suit CSB Barrel Slot Diffusers
- PBHLH** High-Line Plenum box to suit FCD Fan Coil Diffusers
- PBLLH** Low-Line Plenum box to suit FCD Fan Coil Diffusers
- SE** Side Entry spigot
- TE** Top Entry spigot
- CC** Circular Connection
- RC** Rectangular Connection
- FO** Flat Oval Connection
- FDC** Cord-operated Flap Damper (optional)
- FDQ** Quadrant-operated Flap Damper (optional)
- LINED** 6mm acoustic lining (optional) reaction to fire class C-s3-d0 to EN 13501-1: 2007
- BFL** Internal perforated plate for Supply air diffusers (optional)
- BLACK** Plenum painted black to prevent through vision (optional)

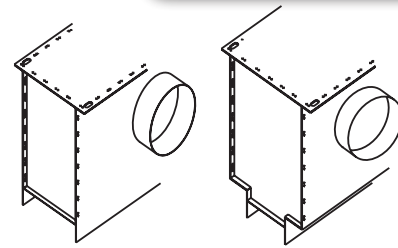
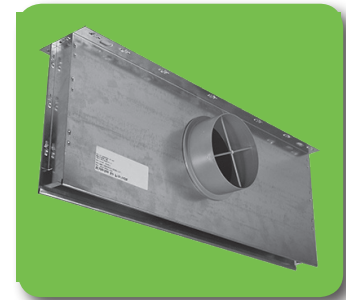

High-Line plenum box

Low-Line plenum box

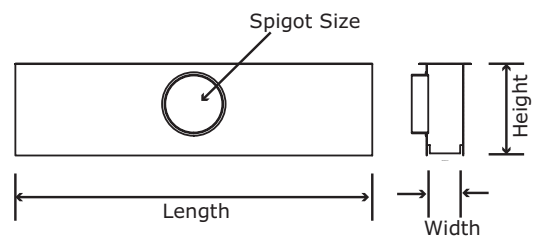

### Features

- Galvanised steel, stitch fixed
- Available in High-Line or Low-Line to accommodate larger spigot sizes
- 1 to 4 connections – Circular, Rectangular or Flat Oval (reduced plenum height)
- Side or Top Entry spigots with optional airflow control damper
- Slotted holes on top plate for easy drop rod installation

### Finish

Galvanised sheet steel

### Dimensions

- Length PBHLH / Fan Coil Diffuser length  
PBHL, PBHLB / Linear Slot diffuser length
- Width PBHLH / Fan Coil Diffuser width  
PBHL, PBHLB / Number of slots
- Height SE – Spigot diameter or height + 100mm as standard  
TE – as specified by customer (200mm minimum recommended)

### Order

When ordering plenum boxes please specify length, width & height, spigot size and position (Top or Side Entry) and control options. Please note that the plenum height should in general be 100mm greater than the spigot diameter (Side Entry applications).

### ORDER EXAMPLE

PBHL/HF/2/1200/250/250/SE/147/2CC/OBSS/LINED

Type \_\_\_\_\_

Diffuser type \_\_\_\_\_

Number of slots \_\_\_\_\_

Plenum box Length \_\_\_\_\_

Plenum box Width \_\_\_\_\_

Plenum box Height \_\_\_\_\_

Entry position \_\_\_\_\_

Spigot Size \_\_\_\_\_

Spigot Number / Shape \_\_\_\_\_

Option \_\_\_\_\_

Option \_\_\_\_\_

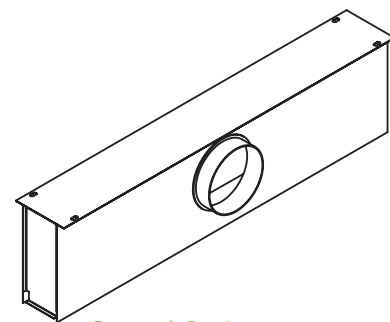

### Control Options

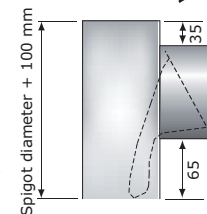

**FDC**

Cord operated flap damper for mounting within circular spigots to plenum boxes.

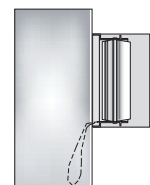

**OBCO**

Cord operated opposed blade damper for installation within square or rectangular plenum spigots.

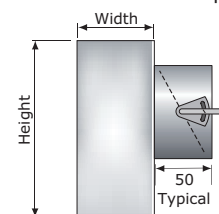

**FDQ**

Flap damper with external quadrant control for mounting within circular spigots to plenum boxes.



## Plenum Boxes

### Selection Criteria (Using the Nomogram)

By way of example, referring to the data in the CS section, consider a diffuser handling 180 l/s total with a pressure drop of 25Pa. Projecting from this volume through the diffuser pressure loss, then pivot on the plenum dimensions to suit the diffuser 2 slot width, which gives a minimum plenum height of approx 280mm. Draw a line from the air flow selection point through the required spigot air velocity and read off the nearest standard spigot size. In this example the spigot diameter exceeds the selected plenum height, so the height now becomes 315 + 100 = 415mm. Alternatively, to maintain the original height, select a suitably sized rectangular spigot (300 x 200 in the example) or use multiple circular spigots.

### Installation

The plenum boxes and neck reducers are supported by four drop rods through a locating hole positioned near each corner.

**Note:** Actual spigot diameter is nominal - 3mm (i.e. 200mm is 197mm actual).

**Note:** Plenum length is determined by linear diffuser selection.

Recommended max air volume for 3 m/s, 35 dBA based on recommended spigot sizes							
Diameter	97	122	157	197	247	312	397
l/s	22	35	58	92	144	229	370

### Performance Nomogram

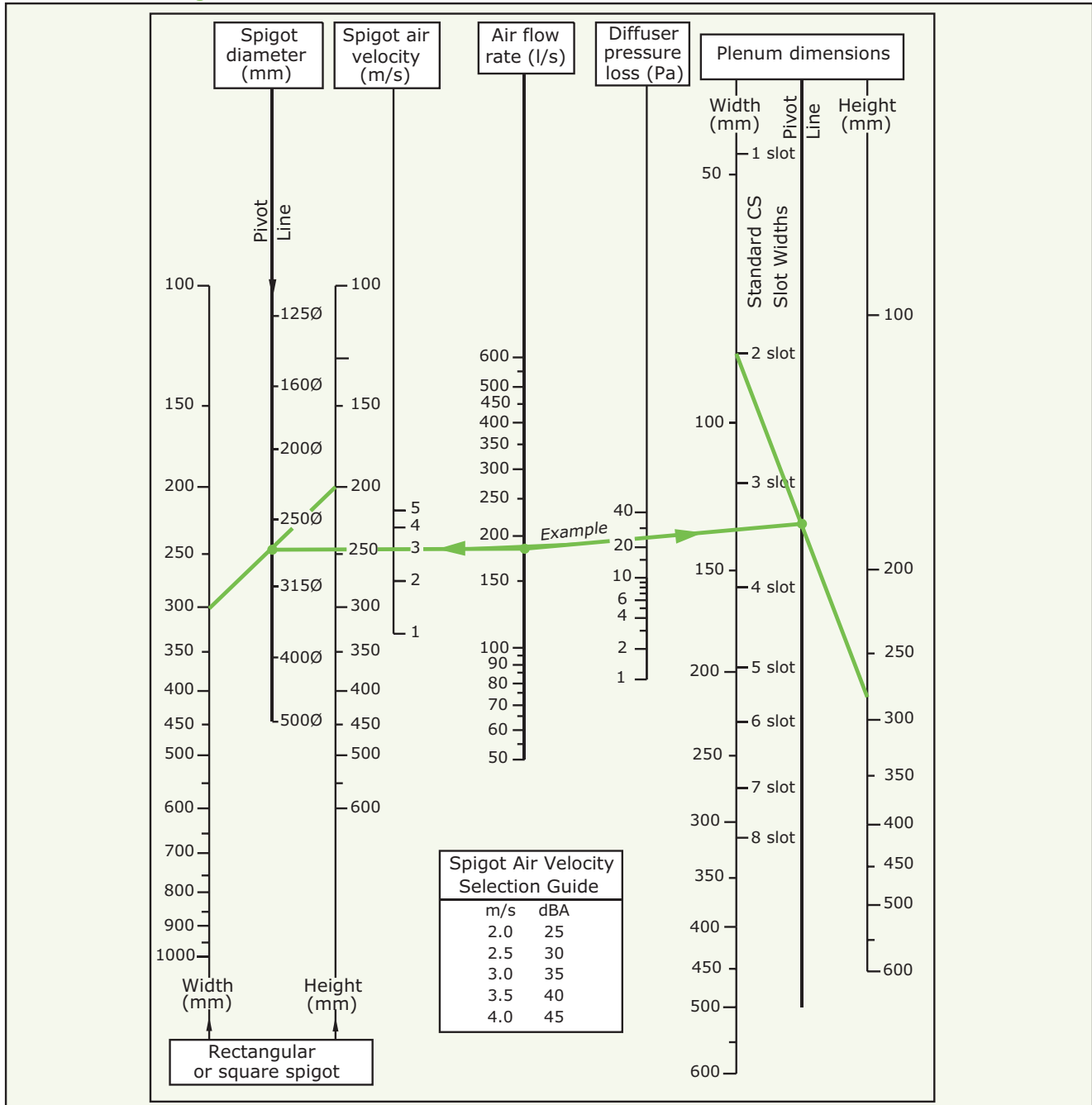



## Waterloo Product Range

### GRILLES

A complete range of products suitable for all wall, ceiling and floor applications. Most grilles are made from aluminium and have a range of fixed or moveable blades designed to give performance whilst remaining aesthetically pleasing to the eye. Grilles are made to customer specified sizes and colours (PPM/G); standard colour PPM9010 (20% Gloss White). The range is complemented by the Aircell range of polymer Grilles.



### DIFFUSERS

Designed to be installed in various ceiling systems, we have a complete range to suit both performance and aesthetical requirements. Most diffusers are made from aluminium and can be ordered with or without plenum chambers for easy duct work. Diffusers can be ordered in customer specified colours (PPM/G); standard colour is PPM 9010 (20% Gloss White). This range is complemented by the Aircell range of polymer Diffusers.



### ACTIVE AND PASSIVE CHILLED BEAMS

The finest quality range of high output active beams, used for ventilated heating and cooling applications. These units have 4 pipe coils to allow heating and cooling circuits to run simultaneously, giving constant and responsive control. The design allows a large optimum capacity and also allows the customer to specify the nozzle type and pitch for individual circumstances.

Active beams are made from steel to a large range of customer specified sizes and as such are suitable for various different ceiling systems. Standard finish is PPM 9010, however other (PPM/G) colours are available on request.

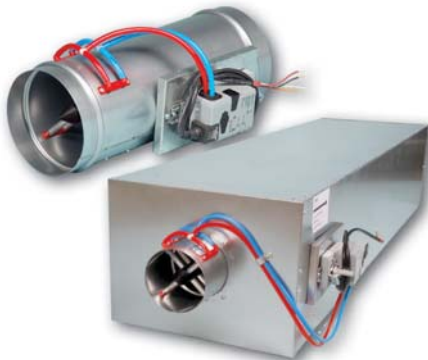

### AIR VOLUME CONTROL DAMPERS

Pressure independent Variable Air Volume and Constant Air Volume dampers made from zintec plate. Most volume dampers are regulated with an electronic motor and sensors and are calibrated to customer specifications before delivery.

The Constant Air Volume damper requires no power source as it is controlled via a mechanical device and calibrated before delivery. All volume dampers can be ordered with a single or double (insulation) skin.

### EXTERNAL LOUVRES

A quality range of products for external wall applications. Made from aluminium, with birdscreen or insect screen options. All louvres are made to customer specified sizes and (PPM/G) colours; standard colour is PPM 9006.



### DISPLACEMENT

A full range of recessed, semi-recessed, floor, wall and corner units providing high ventilation efficiency and excellent comfort. The very low pressure involved also offer quiet installations. Displacement units are available as wall or floor mounted, or indeed integrated within the architectural design.

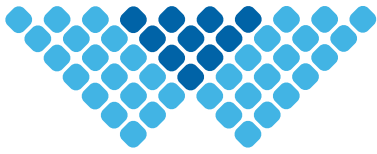

# waterloo

## Waterloo Air Products plc

### Head Office:

Mills Road, Aylesford,  
Maidstone, Kent ME20 7NB  
Tel: +44 (0)1622 711500  
Fax: +44 (0)1622 710648  
email: [sales@waterloo.co.uk](mailto:sales@waterloo.co.uk)  
internet: [www.waterloo.co.uk](http://www.waterloo.co.uk)

### Northern Office:

Hyde Park House, Cartwright Street,  
Newton, Hyde SK14 4EH  
Tel: +44 (0)161 367 1264  
Fax: +44 (0)161 367 1262  
email: [sales@waterloo.co.uk](mailto:sales@waterloo.co.uk)  
internet: [www.waterloo.co.uk](http://www.waterloo.co.uk)



FM 27823



EMS 590755

All products conform to the Terms and Conditions of Waterloo Air Products plc a copy of which are available upon request. Due to our continuous research and development programme, Waterloo Air Products plc reserve the right to alter products and prices without prior notification.

Copyright Waterloo Air Products plc 2018

Waterloo declare that, at the time of print, all products are in accordance with relevant directives, as identified by HEVAC and other European Organisations and will display the CE Marking where required.