

Heating with airborne and geothermal heat



Heating systems ◀
Industrial systems
Refrigeration systems



Heating with airborne and geothermal heat – making the best possible use of renewables

This brochure provides detailed information on sustainable and environmentally responsible heat generation using heat pumps from Viessmann. Heat pumps utilise renewable energy from the ground, the sun, the groundwater or the air. They lower consumption of fossil fuels, conserve valuable resources and reduce CO₂ emissions that damage the environment.

Viessmann heat pumps hold a further advantage – many of them feature active and natural cooling functions. Alongside their classic application as heat generators on cold days, they can also create a pleasant interior climate in summer by bringing refreshing cool air into the house.

Viessmann's extensive product range offers the right heat pump to suit every demand. Even at the planning stage, structural and geological conditions, as well as personal and individual preferences concerning heat demand can be taken into account. Viessmann heat pumps can be used in new build and modernisation projects, they can be operated together with solar thermal systems and even combined with an existing oil or gas heating system to form a hybrid heating system. This gives you plenty of scope for implementing your own ideas or designs.



About this brochure

Heat pumps from Viessmann offer tailor-made solutions for central heating and convenient hot water supply, for both new build and modernisation. The active and natural cooling functions create a pleasant interior in the summer too.



Saving energy and protecting the climate

from page 6

By modernising your heating system, you are making an active contribution towards protecting the climate and saving fossil fuels.



Heating with heat pumps

from page 8

Viessmann heat pumps utilise the potential heating energy that nature has provided, in the form of geothermal heat, and heat from groundwater and the air, which are all available free of charge.



Heating with ice

from page 30

The Vitofriocal ice store system combined with the solar air absorber is an innovative heat source for brine/water heat pumps.



Cooling with heat pumps

from page 34

With natural and active cooling control functions and equipped with the relevant accessories, a brine/water heat pump can also be used to cool living spaces.



Control convenience

from page 58

With the Vitotronic control, operating your Viessmann heat pump is as simple as making a phone call.



UK References

from page 68

Take a look at some of the many successful Viessmann heat pump installations across the UK.

Simple principle, great result

A heat pump works in a similar way to a fridge – simply the other way round.

In a fridge, heat is transferred from the inside to the outside. With a heat pump, this happens exactly the other way round. Heat from the air or the ground is transferred into the living space via the heating system. Vapour from a refrigerant is compressed to increase the temperature, to make it high enough for central heating and DHW heating. During this process, the Vitocal 350-G reaches temperatures up to 70 °C; the Vitocal 300-A and the Vitocal 350-A up to 65 °C. These heat pumps can therefore also be used for modernisation as they can provide a sufficiently high flow temperature for central heating with radiators.

High efficiency thanks to advanced compressor technology

The compression process is vital for the efficiency of a heat pump. Viessmann uses the most advanced compressors in its heat pumps. Their operation is characterised by quiet running, low vibrations and an extremely long service life without maintenance requirements.

To generate heat, for example, heat is drawn from the ambient air and used to evaporate

a refrigerant that boils at low temperatures. The gas thereby created is compressed by the compressor, which causes it to heat up. The gas heated in this way transfers its heat via the condenser to the heating water or domestic hot water, and returns to a liquid state. Finally, the refrigerant, which is still under pressure, is expanded in an expansion valve, and the cycle begins again.

Use with various energy sources

The best heat source for each individual case depends on local conditions and the actual heat demand. Viessmann heat pumps can use various energy sources:

- Air – practically unlimited availability; lowest investment outlay
- Ground – via geothermal collector, geothermal probe or ice store; very efficient
- Water – extremely efficient; observe water quality
- Waste heat – subject to availability, volume and temperature level of the waste heat

Seasonal performance factor

The coefficient of performance (COP) is the ratio of heat transfer to power consumption. The seasonal performance factor is the average of all COPs occurring in a year.

The coefficient of performance is used to compare heat pumps with regard to efficiency, yet it is derived from a particular operating point under defined temperature conditions.

When planning a system, it is necessary to consider its operation over the whole year. For this, the heat volume transferred over the year is given in relation to the overall electrical power drawn by the heat pump system over the same period. This includes the power drawn by pumps and control units, etc. The result is given as the seasonal performance factor.

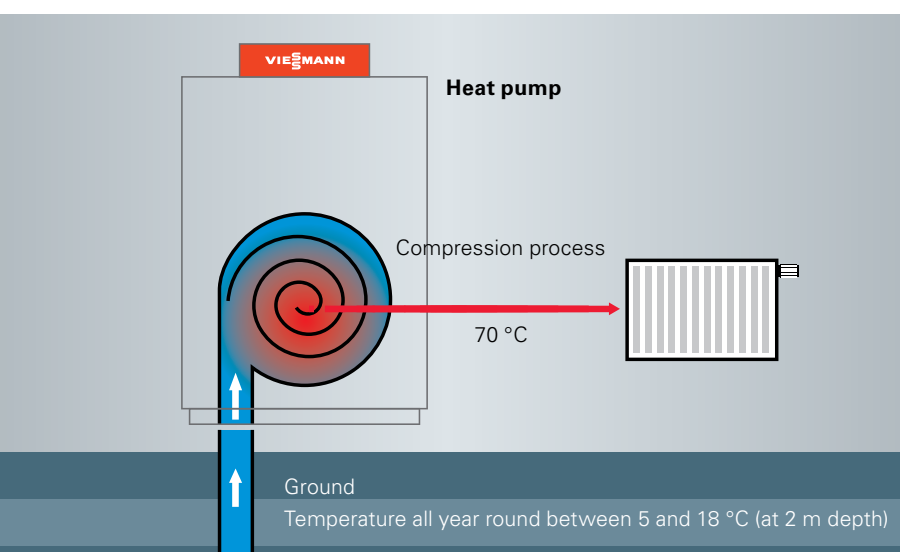

Getting hotter towards the centre: At an initial temperature of between 5 and 18 °C, a flow temperature of up to 70 °C is achieved.

Heat from the ground (collector)

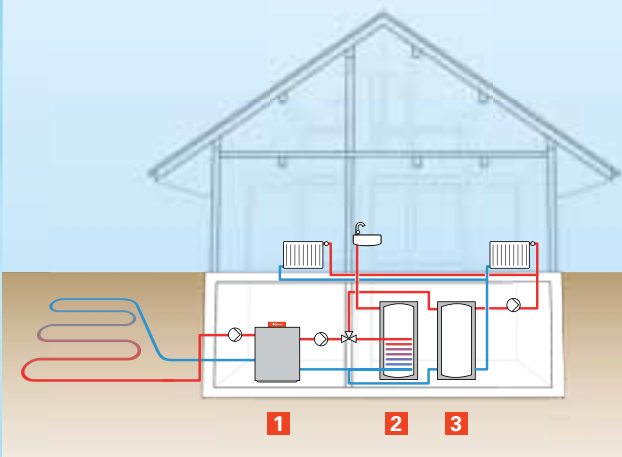

Heat from the ground (probe)

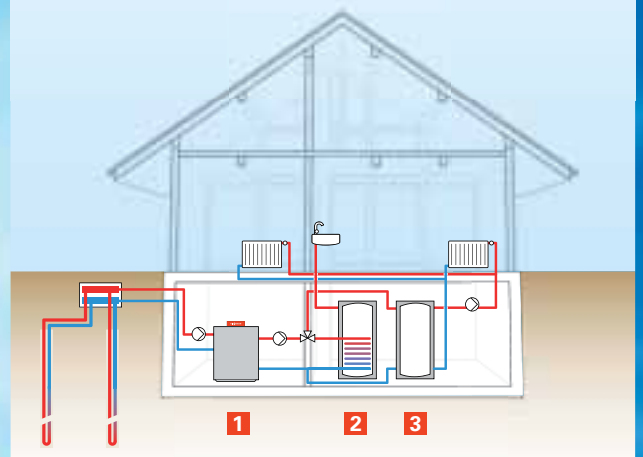

Heat from the ground, the air and the sun (Vitofriocal ice store)

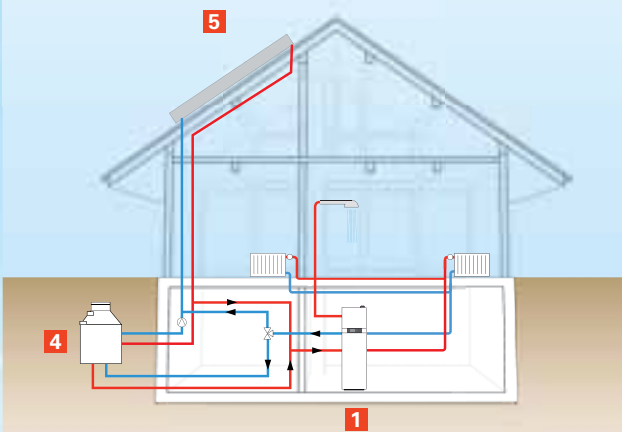

Air/water

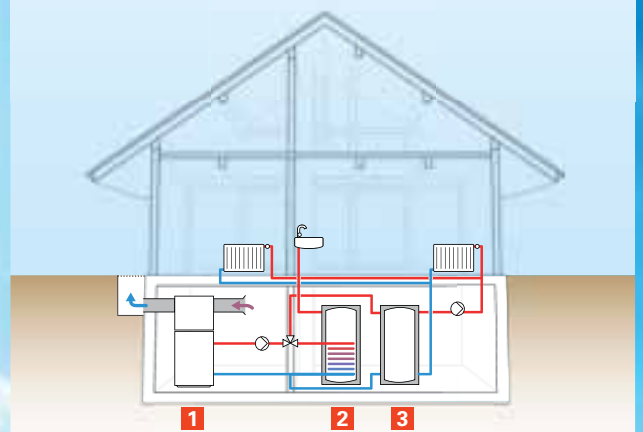

Brine/water (groundwater)

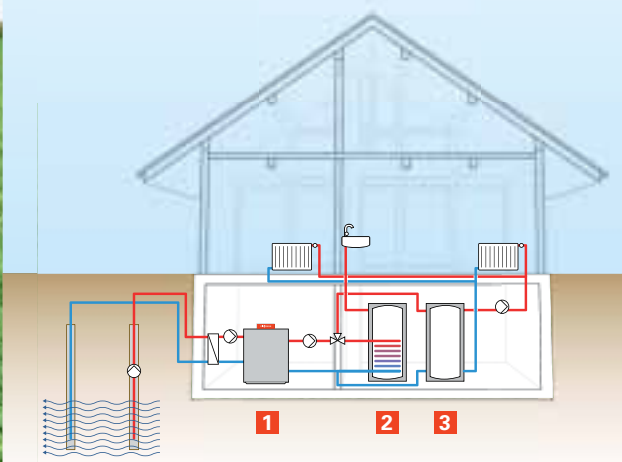

- 1** Vitocal heat pump
- 2** DHW cylinder
- 3** Heating water buffer cylinder
- 4** Ice store
- 5** Solar/air absorber

Brine/water or water/water heat pumps



VITOCAL 350-G

Single stage heat pump (master)

Brine/water heat pump: 20.5 to 42.3 kW

Water/water heat pump: 25.4 to 52.3 kW

For new build and modernisation
Detached houses/apartment buildings

Page 12



VITOCAL 350-G

Two-stage heat pump (master/slave)

Brine/water heat pump: 41.0 to 84.6 kW

Water/water heat pump: 50.8 to 104.6 kW

For new build and modernisation
Apartment buildings, commercial property

Page 12



VITOCAL 300-G

Single stage heat pump (master)

Brine/water heat pump: 5.7 to 42.8 kW

Water/water heat pump: 7.5 to 58.9 kW

For new build and modernisation
Detached houses/apartment buildings

Page 16



VITOCAL 300-G

Two-stage heat pump (master/slave)

Brine/water heat pump: 11.4 to 85.6 kW

Water/water heat pump: 15.0 to 117.8 kW

For new build and modernisation
Apartment buildings, commercial property

Page 16



VITOCAL 242-G/VITOCAL 222-G

Page 22

Compact heat pumps (brine/water)

5.9 to 10.0 kW

Vitocal 242-G cylinder capacity: 220 l, with solar function

Vitocal 222-G cylinder capacity: 170 l

For new build
Detached houses



VITOCAL 200-G

Page 26

Brine/water heat pump

5.8 to 17.2 kW

For new build
Detached houses

Ice store system



Vitofriocal ice store system

Page 30

Compact package, ice store with solar air absorber for brine/water heat pumps

(outdoor ice store, located underground)

6.0 to 17.2 kW

Natural and active cooling



NC-Box

Page 34

Natural cooling box

Up to 5 kW cooling capacity

AC-Box

Active cooling box

Up to 13 kW cooling capacity

Air/water heat pumps



VITOCAL 350-A

Air/water heat pump

(indoor or outdoor installation)

10.6 to 18.5 kW

For new build and modernisation
Detached houses

Page 38



VITOCAL 300-A

Air/water heat pump

(indoor or outdoor installation)

3.0 to 9.0 kW, modulating

For new build and modernisation
Detached houses
Dual mode systems

Page 42



VITOCAL 300-A

Air/water heat pump

(outdoor installation)

7.0 to 8.5 kW

For new build and modernisation
Detached houses

Page 46

Split air/water heat pump



VITOCAL 242-S/222-S

Split compact heat pump (Air/water)

3.0 to 9.0 kW

Vitocal 242-S cylinder capacity: 220 l, with solar function

Vitocal 222-S cylinder capacity: 170 l

For new build/detached houses

Page 50



VITOCAL 200-S

Split air/water heat pump

3.0 to 9.0 kW

For new build and modernisation

Detached houses

Dual mode systems

Page 54



VITOCAL 350-G

Heat pumps with maximum flow temperatures of up to 70 °C are the first choice for high DHW convenience in large detached houses and apartment buildings.

The new high temperature Vitocal 350-G heat pump extends the product range by four output sizes up to 84.6 kW.

EVI for high flow temperatures

The Vitocal 350-G reaches a high flow temperature of up to 70 °C. This is possible thanks to the EVI (Enhanced Vapour Injection) refrigerant circuit, in which the refrigerant is

cooled by enhanced vapour injection and can then be compressed more than would usually be the case. Consequently, the Vitocal 350-G offers convenient DHW heating and also delivers sufficiently high temperatures for modernisation projects with radiator heating systems.

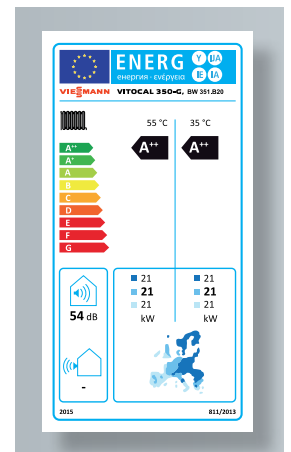

Energy efficiency label
Vitocal 350-G, BW 351.B20



EHPA Quality Label as proof of the COP

Vitocal 350-G
20.5 to 42.3 kW (single stage)
41.0 to 84.6 kW (two-stage)

Highly efficient and very quiet operation

The RCD (refrigerant cycle diagnostic) system, for continuous control of the refrigerant cycle, ensures high efficiency at every operating point. The EVI refrigerant circuit enables the Vitocal 350-G to achieve an extremely high COP of up to 5.0, which contributes to its low running costs.

The low vibration design of the Vitocal 350-G makes this heat pump one of the quietest in its output range.

Where heat demand is higher, the Vitocal 350-G can be operated in two-stage mode with an additional heat pump of the same type, or with a Vitocal 300-G in a master/slave system. A combined master/slave system, comprising a Vitocal 350-G (master) for high flow temperatures for DHW heating and a Vitocal 300-G (slave, without its own control unit) for the required heat load, for example, means optimum matching of the heat pumps to the project.

Vitotronic 200 control unit with communication capability

Following a standardised operating philosophy, Viessmann now uses the convenient Vitotronic 200 control unit in all its heat generators.

Its many functions include operation with user prompts, an integral diagnostic system, control of the instantaneous heating water heater, control of an additional (existing) oil or gas boiler, and of course, the natural or active cooling functions. Furthermore, the Vitotronic 200 is capable of communicating, and via the Vitocom 300 module, it allows the heat pump system to be set up, monitored and optimised over the internet. Another new feature makes it possible to control the heat pump via smartphone and the Vitotrol app.

Prepared for photovoltaic power

The Vitocal 350-G heat pump is already prepared for the utilisation of more affordable power generated on site by a photovoltaic system.

An intelligent controller increases the on-site consumption of power generated by the photovoltaic system. The Vitotronic 200 (type WO1C) control unit offers various control strategies, such as optimised DHW heating.



Vitocal 350-G
(master)

- 1 Vitotronic 200 control unit (type WO1C)
- 2 Condenser
- 3 Large area evaporator for efficient heat exchange
- 4 Hermetically sealed Compliant scroll compressor with EVI (enhanced vapour injection) process



Two-stage Vitocal 350-G (master on the right/slave on the left) as a brine/water or water/water heat pump



Vitoltronic 200 control unit display

Take advantage of these benefits

- Brine/water heat pump
Heating output, single stage: 20.5 to 42.3 kW; two-stage: 41.0 to 84.6 kW
- Water/water heat pump
Heating output, single stage: 25.4 to 52.3 kW; two-stage: 50.8 to 104.6 kW
- Low operating costs through high coefficients of performance: COP to EN 14511 up to 5.0 (brine 0 °C/water 35 °C)
- High DHW convenience
- Low noise and vibration emissions through sound-optimised appliance design
- Low running costs with the highest level of efficiency at any operating point through the innovative RCD (Refrigerant Cycle Diagnostic) system with electronic expansion valve (EEV)
- Mono mode operation for DHW and central heating
- Extremely quiet operation through sound-optimised appliance design
- Flow temperatures of up to 70 °C thanks to EVI compressor for high DHW convenience
- Easy to operate Vitoltronic control unit with plain text and graphic display for weather-compensated heating mode and natural or active cooling
- Master/slave solutions for higher heat demands, e.g. combination with the Vitocal 300-G

For specification, see page 60



VITOCAL 300-G

The Vitocal 300-G heat pump taps into the renewable heat stored underground or in groundwater. A two-stage version is available for high heating outputs.

As a brine/water heat pump, the Vitocal 300-G draws heat from highly efficient heat sources. For this purpose, a geothermal probe, a Vitofriocal ice store system, or a geothermal collector is installed on the property. In all these cases, the heat pump covers the entire energy demand, even on colder days.

As an alternative, depending on the location of the house, it may also be possible to utilise the heat contained in groundwater. In this case, the Vitocal 300-G is simply configured for operation as a water/water heat pump. It can be used for new build and modernisation in detached houses and apartment buildings.



Energy efficiency label
Vitocal 300-G, BW 301.B10



EHPA Quality Label as proof of the COP

Vitocal 300-G

Brine/water, single stage: 5.7 to 17.2 kW; two-stage: 11.4 to 34.4 kW

High output and quiet operation

The powerful Compliant scroll compressor fitted in the Vitocal 300-G heat pump is outstanding on account of its high operational safety, reliability and especially quiet operation. Essentially, this is due to the twin sound insulation that includes anti-vibration mounts to prevent structure-borne noise and insulates the casing against airborne noise. At the same time, the compressor guarantees the highest coefficient of performance (COP up to 5.0) and flow temperatures up to 65 °C.

The Refrigerant Cycle Diagnostic (RCD) system constantly monitors the refrigerant circuit in the Vitocal 300-G and, in conjunction with the electronic expansion valve, ensures the highest efficiency at any operating point, which results in high seasonal performance factors.

Vitotronic 200, with energy statement facility

The Vitotronic 200 is simple and intuitive to operate, thanks to the plain text user prompts and graphic display. Amongst other features, it enables an integral differentiated energy statement.

Modular solution for higher heat demand

For residential buildings with a higher heat demand, the two-stage Vitocal 300-G, based on the master/slave principle is the right choice. It can also be configured for the ground or groundwater as the heat source. For this purpose, two heat pumps are linked together. This delivers the high heating output required and increases the operational reliability of the entire system. The modular design, with separate compressor circuits, also ensures particularly high levels of efficiency in partial load operation, and enables the simultaneous operation of central and DHW heating.

With five output stages as a master or master/slave version, various combinations can be realised and matched to the required heat demand. Because of this flexibility, systems can be configured so that runtimes match demand, thus saving you money. The master module regulates the slave module. Furthermore, the entire system can be equipped with high efficiency pumps.

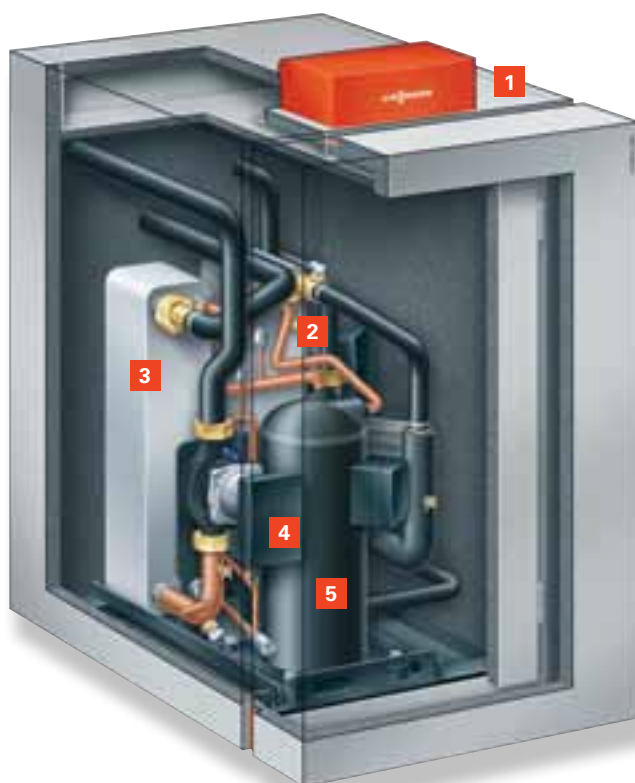
**Vitocal 300-G**

- 1** Vitotronic 200 heat pump control unit
- 2** Condenser
- 3** Large area evaporator for an efficient heat exchange
- 4** High efficiency pump
- 5** Hermetically sealed Compliant scroll compressor



The Vitocal 300-G heat pump utilises the renewable heat stored underground or in groundwater.



Two-stage heat pump Vitocal 300-G (master/slave) – a pipework set with fittings and shut-off valves is available for the hydraulic connection of the heat pump modules. Fully wired cables are used to connect the control unit.

Take advantage of these benefits

- Maximum efficiency for new build/modernisation in detached houses/apartments
Brine/water heat pump:
Heating output, single stage: 5.7 to 17.2 kW; two-stage: 11.4 to 34.4 kW
Water/water heat pump:
Heating output, single stage: 7.5 to 22.6 kW; two-stage: 15 to 45.2 kW
- Vitocal 300-G: with integral HE pump for brine and heating circuits, plus circulation pump for cylinder heating, safety assembly with safety valve, pressure gauge and air vent valve (for type BWC)
- Low operating costs through high coefficients of performance: COP to EN 14511 up to 5.0 (brine 0 °C/water 35 °C) and integral HE pumps (for Vitocal 300-G, type BWC)
- Maximum flow temperatures up to 65 °C
- High efficiency all year round at any operating point through innovative RCD system with electronic expansion valve
- Low noise and vibration levels thanks to sound-optimised appliance design – sound power level < 42 dB(A)
- Vitotronic 200 control unit with energy statement
- Control of a Vitovent 300-F mechanical ventilation unit
- Prepared for Smart Grid and utilisation of photovoltaic power generated on site
- Control of a Vitovent 300-F ventilation unit
- Master/slave solutions for high flexibility, for example combination of Vitocal 300-G and 350-G

For specification, see page 61

Vitocal 300-G

Brine/water, single stage: 21.2 to 42.8 kW; two-stage: 42.4 to 85.6 kW



Energy efficiency label
Vitocal 300-G, BW 301.A21



EHPA Quality Label
as proof of the COP,
for subsidy according
to the German market
incentive programme

Specialist for high output levels

The Vitocal 300-G is the specialist for large detached houses and apartment buildings. It utilises heat that's right on your doorstep, either with a single stage brine/water heat pump, from 21.2 to 42.8 kW, or with a water/water heat pump from 28.1 to 58.9 kW – each tailored to the specific heat demand.

For apartment buildings or applications that require a very high output, the two-stage Vitocal 300-G, based on the master/slave principle, is the right choice. It can deliver a heating output from 42.4 to 85.6 kW (brine/water) or from 56.2 to 117.8 kW (water/water). You also have the choice between the groundwater or the ground as your preferred heat source. Where this output is still not enough, the cascade function integrated into the control unit enables output to be raised up to 589 kW (water/water).

Powerful and reliable

At the heart of the Vitocal 300-G lies its powerful Compliant scroll compressor. This convinces with a high degree of operational safety and reliability. In conjunction with the large heat exchangers and the integral

refrigerant manifold, the Vitocal 300-G achieves a high COP and flow temperatures up to 60 °C.

Quiet operation and high output are not mutually exclusive

The hermetically sealed casing and particularly clever appliance design enable a reduction in noise emissions in the Vitocal 300-G that far exceeds expectations in this output range.

RCD system for highest level of efficiency

RCD stands for Refrigerant Cycle Diagnostic system. It provides constant monitoring of the refrigerant circuit within the Vitocal 300-G and, in conjunction with the electronic expansion valve, ensures the highest level of efficiency at any operating point.

Perfect for high heating output

Especially for a higher heat demand, the Vitocal 300-G is the first choice, because several heat pumps can be linked via the heating flow and return. This does not just deliver the higher heating output required, but it also increases the operational reliability of the entire system. The modular design, with separate compressor circuits, also ensures particularly high levels of efficiency in partial load operation, and enables the simultaneous operation of central and DHW heating.

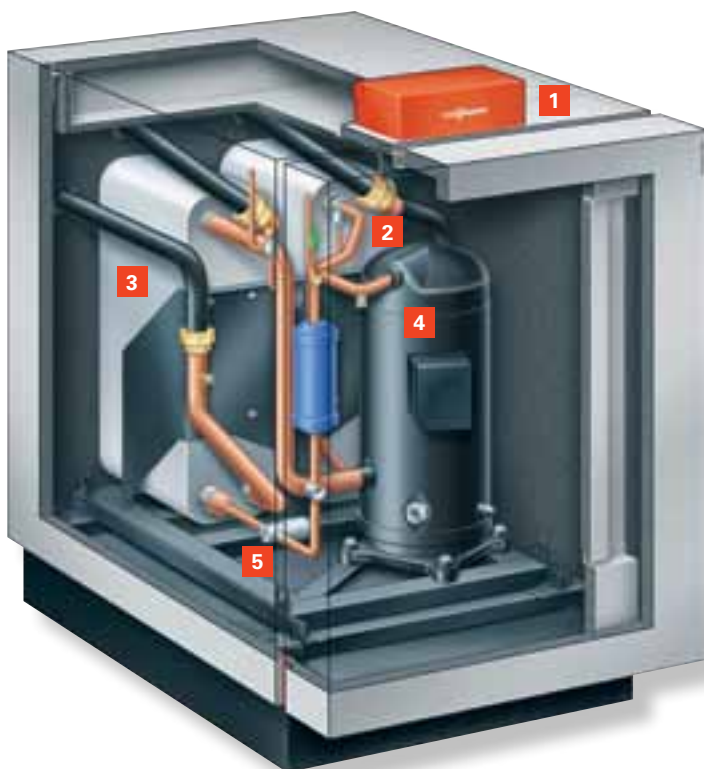
**Vitocal 300-G**

- 1 Vitotronic 200 weather-compensated, digital heat pump control unit
- 2 Condenser
- 3 Large area evaporator for efficient heat exchange
- 4 Hermetically sealed Compliant scroll compressor
- 5 Electronic expansion valve



Combination of Vitocal 300-G as a brine/water or water/water heat pump

Modular solution in master/slave operation

With three output sizes, as master or master/slave version, various combinations can be realised, which can all be precisely matched to the actual heat demand. The availability of different versions and the ability to size according to demand enables optimised runtimes and economical operation. The master module regulates the slave module. By combining different output sizes, system users have the option of matching the environmentally responsible heating system to their specific heat demand as efficiently as possible by utilising different modules.

Take advantage of these benefits

- Brine/water heat pump
Heating output, single stage: 21.2 to 42.8 kW; two-stage: 42.4 to 85.6 kW; maximum 428 kW (as cascade)
- Water/water heat pump
Heating output, single stage: 28.1 to 58.9 kW; two-stage: 56.2 to 117.8 kW; maximum 589 kW (as cascade)
- Low operating costs through high coefficients of performance: COP to EN 14511 up to 4.8 (brine 0 °C/water 35 °C) (COP = coefficient of performance)
- Flow temperatures up to 60 °C
- Mono mode operation for DHW and central heating
- Low operating costs with the highest level of efficiency at any operating point due to the innovative Refrigerant Cycle Diagnostic (RCD) system with electronic expansion valve (EEV)
- Low noise and vibration levels thanks to sound-optimised appliance design, sound power level ≤ 44 dB(A)
- With integral energy statement
- Vitotronic 200 heat pump control unit with user prompts for weather-compensated heating operation
- Prepared for Smart Grid and utilisation of photovoltaic power generated on site
- Easier handling through small and light modules

For specification, see pages 61, 62

Heat pumps

Vitocal 242-G
Vitocal 222-G

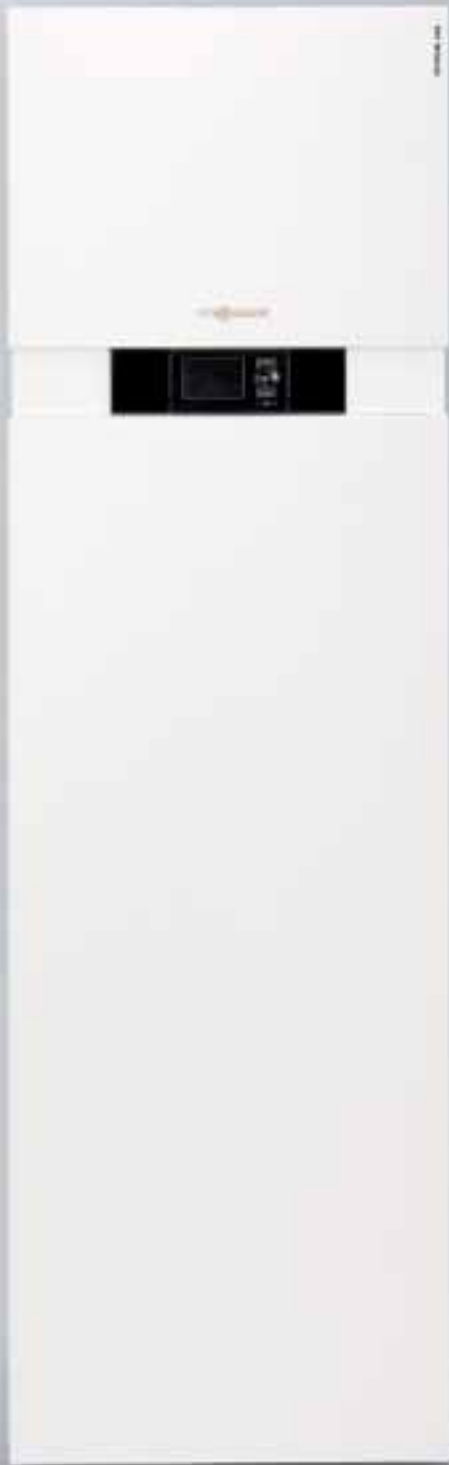

VITOCAL 242-G

VITOCAL 222-G

Compact brine/water heat pumps with DHW cylinder and, as an alternative, the option to connect a solar thermal system.

Complete and extremely compact – Vitocal 242-G and Vitocal 222-G heat pumps are fully equipped with all of the components required for DHW and central heating. With heating outputs of between 5.9 and 10.0 kW, they are designed for use in detached houses, and flow temperatures up to 60 °C mean they can also be used with conventional radiators.

The Vitocal 242-G and Vitocal 222-G are attractively priced alternatives to the compact appliances of the 300 series. Equipped with a Compliant scroll compressor and a thermostatically controlled expansion valve, they achieve coefficients of performance up to 4.5 (to EN 14511 at brine 0 °C/water 35 °C). For the heating and brine circuits, three-stage adjustable circulation pumps are integrated into the appliances.

Operating the appliances is extremely easy thanks to the Vitotronic control unit.

Vitocal 242-G fully prepared for solar operation

The Vitocal 242-G is fully prepared for the connection of a solar thermal system for DHW heating. A 220 l solar cylinder and a solar control unit enable high solar yields to be achieved.

Vitocal 222-G with large DHW cylinder

The Vitocal 222-G compact heat pump offers high levels of DHW convenience thanks to its 170 l DHW cylinder, which is heated via an internal indirect coil.

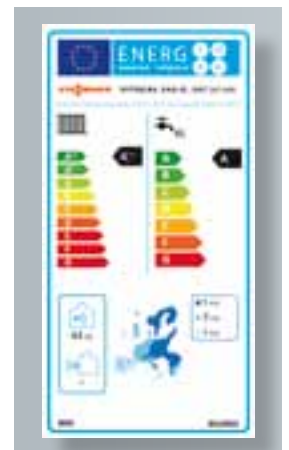

Energy efficiency label
Vitocal 242-G, BWT 241.A08

Vitocal 242-G, compact brine/water heat pump with solar thermal system

- 1 Heat pump compact appliance (brine/water)
- 2 Underfloor heating system
- 3 Vitosol solar collectors
- 4 Geothermal probe
- 5 Solar-Divicon pump module



Vitocal 242-G
 Vitocal 222-G
 5.9 to 10.0 kW

Natural heat for modern detached houses

The Vitocal 242-G and Vitocal 222-G compact heat pumps are specifically designed for detached houses. With their extremely compact dimensions of just over 0.4 square metres, they take up only a small floor area. With integral DHW cylinder, brine and heating circuit pumps plus a three-way diverter valve, these compact appliances are quick and easy to install. They are offered in two different versions: the Vitocal 242-G with solar function and a generously sized DHW cylinder with 220 l capacity, and the Vitocal 222-G which has a 170 l cylinder. Both heat pumps offer high DHW convenience.

Extremely easy to operate

The Vitocal 222-G, like all compact appliances, is also equipped with the extremely user friendly Vitotronic control unit. If in doubt, help is available at the push of a button. The graphic interface will also display heating curves and switching times.

Particularly quiet operation

The sound-optimised appliance design makes these compact heat pumps particularly quiet so that they can even be installed close to the living space.

Compact and ready to connect

The casing may be split for easier handling. The heat pump is supplied ready to connect. Variable connection accessories ensure an easy installation on site.

Heating naturally – naturally cooling as well

The compact heat pumps can provide a pleasant climate in a low energy house, even on hot summer days. The natural cooling function brings cool underground temperatures into the home. For this, the Viessmann NC-Box is required as an accessory.

Vitocal 242-G including optional utilisation of solar energy

With the Vitocal 242-G, the connections for a solar thermal system are already in place, with the required hydraulic connections and the control unit integrated. The powerful collectors and matching system components from Viessmann back up the heat pump – meaning in an average year, 50 to 60 percent of energy usually spent on DHW heating can be saved.

Vitocal 242-G

- 1 Heating lance
- 2 Enamelled DHW cylinder
- 3 Vitotronic 200 heat pump control unit
- 4 Integral solar indirect coil
- 5 PWM-controlled cylinder loading pump (pulse width modulation)
- 6 Circulation pump, primary
- 7 Circulation pump, secondary
- 8 Diverter valve, heating/DHW
- 9 Integral instantaneous heating water heater

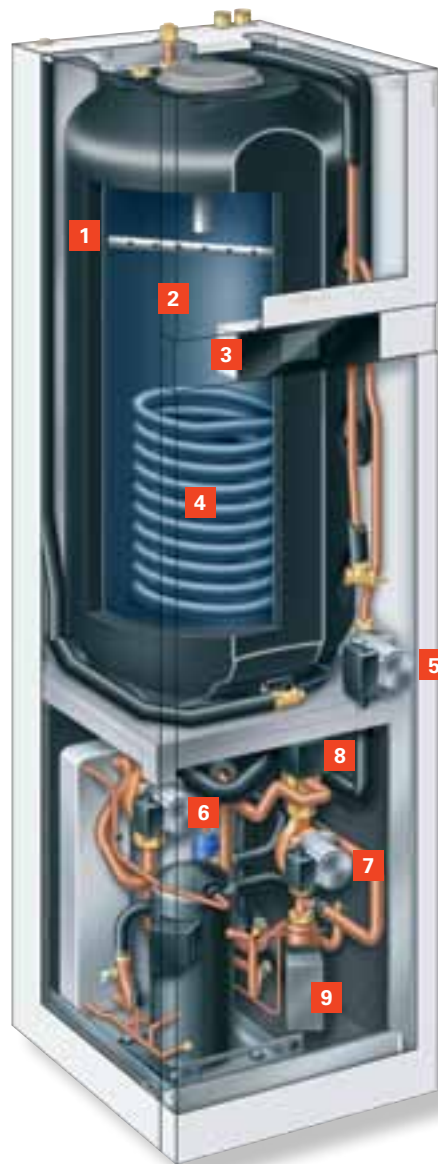



The compact heat pumps fully live up to their reputation: Their low space requirement and lack of service clearances to the side means that they fit easily into the tightest of recesses.



Easy to operate Vitotronic control unit with straightforward navigation and clear menu tree.

Take advantage of these benefits

- Compact brine/water heat pumps with heating outputs from 5.9 to 10.0 kW
- Low operating costs through high coefficients of performance: COP to EN 14511 up to 4.5 (brine 0 °C/water 35 °C) (COP = coefficient of performance)
- Maximum flow temperature: 60 °C
- High DHW convenience through integral DHW cylinder with a 220 l capacity in the Vitocal 242-G (Vitocal 222-G with 170 l capacity)
- Very quiet thanks to the sound-optimised appliance design with a sound power level of 43 dB(A) at 0/35 °C
- Easy-to-use Vitotronic control unit with plain text display
- Ready to connect, ex works
- Easy handling through small footprint, reduced height and split casing
- Easy installation through variable connection accessories
- Prepared for Smart Grid and utilisation of photovoltaic power generated on site
- Instantaneous heating water heater integrated as standard
- Optimised for using power from photovoltaic systems generated on site

For specification, see page 61



VITOCAL 200-G

Attractively priced heat pump for uncomplicated heat supply and high level of DHW convenience in new build.

With its excellent price/performance ratio, the Vitocal 200-G compact brine/water heat pump is ideally suited to detached and two-family houses. With its output spectrum of 5.8 to 17.2 kW in mono mode, it delivers a convenient heat supply all year round.

Thanks to innovative technology, including an efficient Compliant scroll compressor, the Vitocal 200-G achieves a maximum flow temperature of 60 °C and is therefore an affordable heat pump for new build.

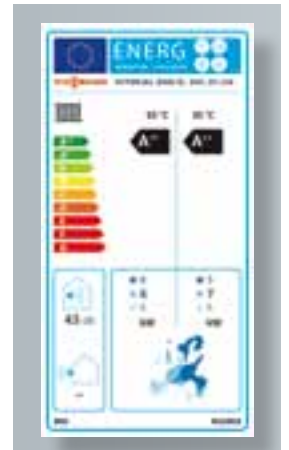

Energy efficiency label
Vitocal 200-G, BWC 201.A10



The Vitocal 200-G is certified in accordance with the EHPA Quality Label for heat pumps.

Vitocal 200-G

5.8 to 17.2 kW

Two heating circuits for individual heating convenience

This convenient brine/water heat pump offers all functions required for use in a new detached or two-family house. The weather-compensated Vitotronic 200 control unit allows two separate heating circuits to be connected.

Installation and assembly made easy

The Vitocal 200-G is delivered complete with integral HE pumps for the brine and heating circuits, circulation pump for cylinder heating, and the safety assembly. This makes it much easier for the contractor to install.

Easy to use Vitotronic 200 control unit

The Vitotronic 200 control unit with plain text and graphic display for weather-compensated heating mode is straightforward and intuitive to use. Operation with user prompts allow functions to be called up and the required settings to be made quickly.

Cooling and ventilation

The natural cooling function is already included. To use this, the Vitocal 200-G must be extended by means of an NC-Box from the range of accessories. The Vitotronic 200 can also be used to control the Vitovent 300-F ventilation unit, thus ensuring pleasant interior temperatures.

Prepared for photovoltaic power

The Vitocal 200-G heat pump is already prepared for the utilisation of more affordable power generated on site by a photovoltaic system. An intelligent controller increases on-site consumption of power generated by the photovoltaic system. The Vitotronic 200 (WO1C) control unit offers various control strategies, such as optimised DHW heating.

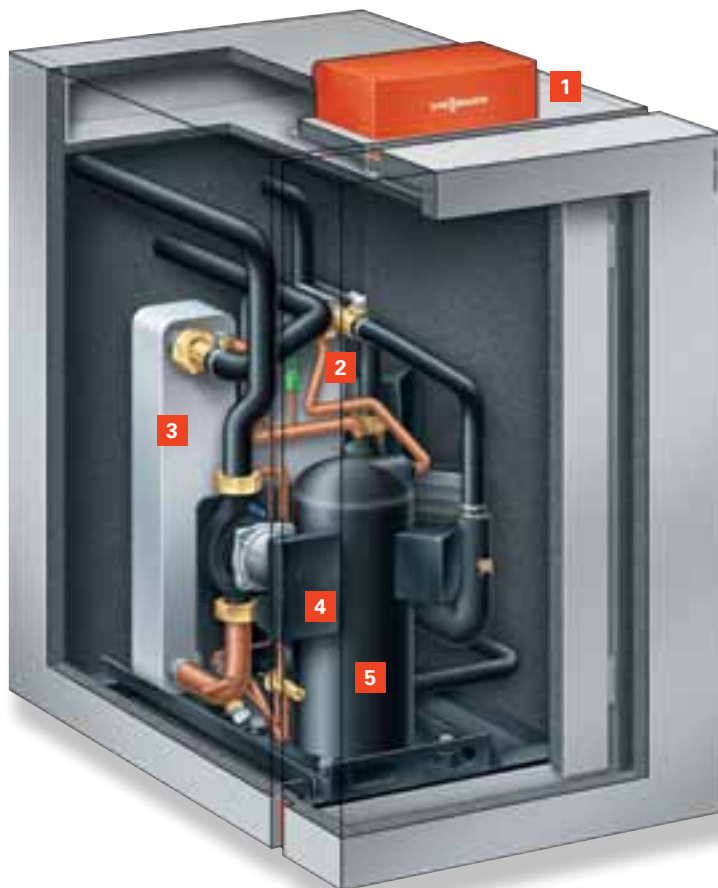

Vitocal 200-G

- 1 Vitotronic 200 control unit
- 2 Condenser
- 3 Large area evaporator for efficient heat exchange
- 4 High efficiency pump
- 5 Hermetically sealed Compliant scroll compressor



Attractively priced Vitocal 200-G brine/water heat pump



Vitotronic 200 control unit display

Take advantage of these benefits

- Brine/water heat pump with heating output from 5.8 to 17.2 kW
- Attractively priced heat pump for detached/two-family houses in the new build sector
- Low operating costs through high coefficients of performance: COP to EN 14511 up to 4.5 (brine 0 °C/water 35 °C) (COP = coefficient of performance)
- Provides DHW and central heating in mono mode operation all year round
- Maximum flow temperature up to 60 °C
- Quiet operation with low vibrations thanks to sound-optimised appliance design; sound power level < 45 dB(A)
- Vitotronic 200 control unit with user prompts, plain text and graphic display for weather-compensated operation
- Natural cooling function and control of the Vitovent 300-F ventilation unit
- HE circulation pump for the brine and heating circuits, and circulation pump for cylinder heating are already fitted
- Control of a Vitovent 300-F mechanical ventilation unit
- Easy to install through complete equipment level and pre-assembly
- Heat meter can be retrofitted (option)
- Prepared for Smart Grid and optimised utilisation of power generated on site

For specification, see page 61



Heating with ice

Vitofriocal ice store – innovative energy source for brine/water heat pumps

The use of an ice store as an energy source is a particularly innovative solution. The ice store consists of a tank with built-in heat exchangers which is buried in the garden and filled with ordinary tap water. Special solar air absorbers are installed on the roof of the house, which draw heat from the ambient air and insolation and supply it to the cylinder. The ice store also draws heat directly from the ground.

Using crystallisation energy for heating

The heat pump extracts the energy required for central heating and DHW heating from the water stored in the tank as needed. If the temperature in the tank falls to freezing point, more energy is obtained from the freezing of

the water – hence the term ice store. During the transition from water to ice, the amount of crystallisation energy released is equivalent to that required for the inverse process of thawing. With an ice store measuring ten cubic metres – the standard size for a detached house – this corresponds to the energy content of approximately 120 litres of fuel oil.

The key difference being that the fuel oil is entirely consumed to generate heat, while the water content of the ice store represents an almost limitless heat source that is continuously regenerated with energy from the sun and air.



Ice formation around the heat exchanger in the ice store.

Heat source

Vitofriocal ice store system 6.0 to 17.2 kW



Ice store tank with 10 m³ water content. The water acts as the storage medium and freezes under controlled conditions when required.

Package solutions for easy installation

Viessmann is the only heat pump manufacturer to offer the innovative Vitofriocal ice store system. For heat pumps with a rated heating output from 6.0 to 17.2 kW, various standardised system packages are currently available which greatly facilitate engineering and ordering of components. These packages comprise an ice store with built-in heat exchangers, solar air absorbers with a roof mounting system and the heat transfer medium for the primary circuit. Larger properties with a greater heat demand require a customised ice store and solar air absorbers. Viessmann offers the relevant support for this.

Precisely tailored system components

The system packages are designed so that the available heat sources – outdoor air, solar energy and geothermal heat – are used as efficiently as possible. All components are precisely tailored to each other for this purpose. This ensures that the heat pump always works efficiently, no matter which heat source, solar air absorber or ice store is available.

No official permits required

Another benefit of the Vitofriocal ice store system is that it does not require the costly drilling that is needed for tapping geothermal energy from deep in the ground, or the extensive groundwork involved when laying geothermal collectors over a large area. Nor does it require any official permits, as the ice store has no impact on groundwater.

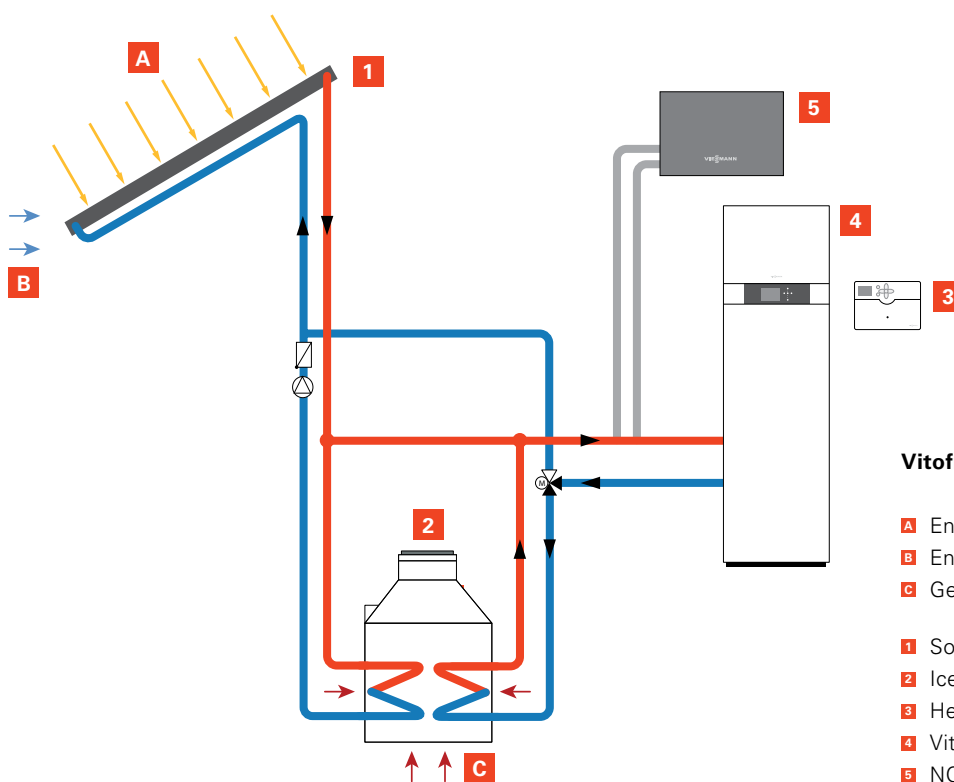

Vitofriocal ice store system

- A** Energy from insolation
- B** Energy from ambient air
- C** Geothermal energy
- 1** Solar air absorber
- 2** Ice store
- 3** Heat source manager
- 4** Vitocal heat pump
- 5** NC-Box for natural cooling



Complete ice store package with solar air absorber for ground brine/water pumps with an output of 6.0 to 17.2 kW.

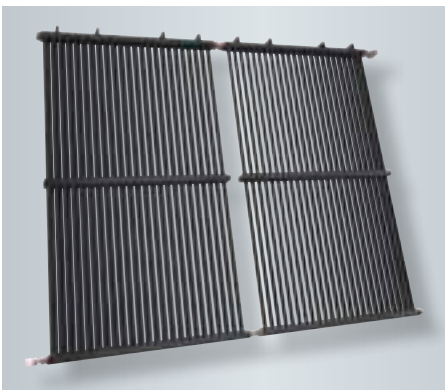

Solar air absorber as a direct heat source for the heat pump or for regenerating the ice store

Take advantage of these benefits

- Combined utilisation of ambient air, the ground and insolation as heat source
- No drilling – no environmental risk, no permits required
- Low operating costs thanks to the high COP of the heat pumps, up to 5.0 (B0/W35) to EN 14511
- Particularly high efficiency thanks to intelligent heat source management and heat pump with RCD (Refrigerant Cycle Diagnostic) system with electronic expansion valve (EEV)
- Easy-to-use Vitotronic control unit integrated in the heat pump



Cooling with heat pumps

Besides generating high levels of heating comfort and reliable DHW heating, heat pumps also create a pleasant interior in hot weather.

Viessmann heat pumps not only provide heating during winter months. Some models also include an additional cooling function for summer periods.

Passive or active cooling

There are two different ways to cool a building:

- **Passive cooling:**
This is where the brine medium or the groundwater absorbs the energy from the heating circuit via a heat exchanger and transfers it outside. This function is also called natural cooling, as it transfers the excess heat to natural ambience. Apart from the control unit and circulation pump, the heat pump remains switched off.
- **Active cooling:**
For this, the function of the heat pump is simply reversed. This method of cooling can be achieved with reverse operation. This means that the refrigerant circuit is reversed internally or reversal is achieved by an external changeover of the primary and secondary circuits. As with a fridge, the heat pump then actively generates a cooling capacity. This is called active cooling.

Natural cooling – naturally

While the ground or groundwater is used in winter to provide energy for heating, in summer it can be used for natural cooling. With the natural cooling function, the control unit only starts the primary pump and heating circuit pump. This means the relatively hot water from the underfloor heating system can transfer its heat via the heat exchanger to the brine in the primary circuit. This extracts heat from all rooms that are connected, which makes natural cooling a particularly energy efficient and affordable way to cool interiors.



NC-Box

Optional equipment for Viessmann heat pumps to provide passive cooling

For specification, see page 64



AC-Box

Optional equipment for Viessmann heat pumps to provide active cooling

For specification, see page 64

Energy efficient and affordable cooling with the NC-Box

The Viessmann NC-Box helps heat pumps to provide cooling in a completely natural and really quite simple way. On hot summer days, the temperatures inside the house are higher than those in the ground or groundwater. The heat pump control unit switches to natural cooling, and uses the ground or groundwater to dissipate the heat from the living space.

Saving while cooling

The natural cooling function does not use all the technology of the brine/water heat pump. This means that, apart from the control unit and circulation pumps, all other functions remain off. Only a very small amount of power is therefore consumed for operation. This makes natural cooling a particularly energy efficient and affordable method for cooling buildings.

All in one box

In the Viessmann natural cooling box, all components are prefitted. This makes the thermally insulated box not only compact, but also particularly simple and quick to install.

With mixer

The natural cooling box is equipped with a mixer for fitting in the cooling circuit. The integral mixer enables continuous operation without falling below the dew point.



The effective thermal insulation of the NC-Box prevents the formation of condensate.

The AC-Box efficiently combines heating and cooling

The Viessmann AC-Box combines active and natural cooling in heat pump systems, thus making them even more versatile and convenient. The system changes over automatically according to the required room temperature. If only a low cooling capacity is required, natural cooling is sufficient, however, when that is no longer enough, active cooling is added.

Cooling using tiny amounts of energy

With natural cooling, the compressor circuit is not required. Only the brine and heating circuit pumps are operational and utilise the temperature differential between the rooms and the ground or groundwater. In this way, rooms can be cooled very cost effectively.

Keeping cool when it's hot outside

The compressor circuit 'kicks in' for active cooling. However, it does not provide heating – the internal control unit, in conjunction with the AC-Box, reverses the output and input functions to actively transfer heat out of the building to the geothermal probe. Cold water then flows through the heating circuit itself – cooled down to 7 °C if required.

Utilising extracted energy

Incidentally, direct use can also be made of the heat transferred from the interior in this way, for example for DHW heating or to heat a swimming pool. This means cooling and heating functions can be combined extremely effectively.



Well developed technology: The AC-Box (to the left of the heat pump) simply starts the relevant heat pump function – either active or the natural cooling, depending on the actual cooling demand.



VITOCAL 350-A

This air/water heat pump can handle high flow temperatures and is therefore ideal for modernisation projects.

The Vitocal 350-A air/water heat pump with a rated heating output from 10.6 to 18.5 kW is particularly suitable for modernisation projects. Thanks to enhanced vapour injection in the compression process (EVI cycle), flow temperatures as high as 65 °C can be achieved – even at wintry outside temperatures. This means the Vitocal 350-A is also suitable for installation in older heating systems with radiators. For higher efficiency still, we would recommend replacing individual radiators with ultra-low temperature ones.

The Vitotronic 200 heat pump control unit has an integral cascade function for up to five air/water heat pumps. Cumulative heating outputs of up to 92.5 kW are therefore possible to cover a high heat demand.

RCD system for particularly high efficiency

The electronic expansion valve and RCD system also ensure an extremely high level of efficiency for the Vitocal 350-A all year round. For air/water heat pumps, the Vitocal 350-A offers a high coefficient of performance of up to 3.6 (in accordance with EN 14511 at air 2 °C/water 35 °C). This results in high seasonal performance factors and very low operating costs.

Space saving thanks to outdoor installation

The Vitocal 350-A can be installed either indoors or outdoors. The three-stage radial fan in the heat pump, as well as the flow-optimised air routing and the sound insulated casing together make the Vitocal 350-A extremely quiet. During night operation the multi stage fan control unit reduces the fan speed and thus the noise emissions even further.

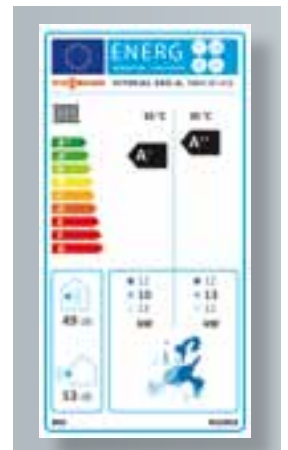

Energy efficiency label
Vitocal 350-A, AWHI 351.A10



The Vitocal 350-A is certified in accordance with the EHPA Quality Label for heat pumps.

Vitocal 350-A

10.6 to 18.5 kW

Ideal for modernisation

The Vitocal 350-A air/water heat pump makes modernising easy. The additional vapour injection in the compression process (EVI cycle) enables a flow temperature of up to 65 °C. It is therefore ideal for older heating systems with existing radiators. For this, the heat pump draws its energy from the ambient air.

High DHW convenience

Subject to system version, a higher flow temperature enables a water temperature of up to 55 °C inside the DHW cylinder. This allows the Vitocal 350-A to deliver a particularly high level of DHW convenience. The Vitocal 350-A achieves the high flow temperature of 65 °C, even at outside temperatures of minus 10 °C.

RCD guarantees efficient operation

RCD stands for Refrigerant Cycle Diagnostic system. In the Vitocal 350-A, it is responsible for permanently monitoring the refrigerant circuit. This, in conjunction with the electronic expansion valve (EEV), ensures the highest efficiency at every operating point. Alongside this, important operating parameters are saved and called up, when required, for diagnosis, optimisation, energy statements and to calculate the seasonal performance factor (SPF).

Spot on

If the heat pump is installed outside, the heat needs to be "transported" to the interior of the house. For this, you can rely on Viessmann's competence in heating systems. All the pipework required for routing underground, as well as the entire range of accessories, are provided from one single source, and are perfectly matched to one another.

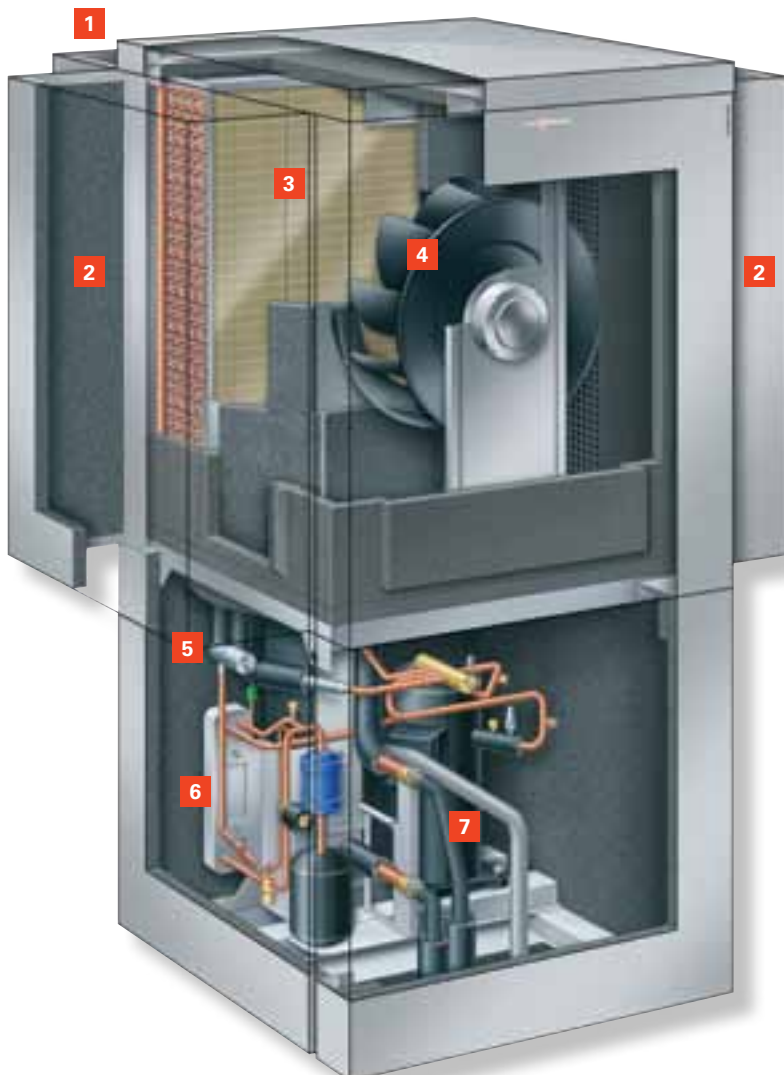

Vitocal 350-A

- 1 Intake side
- 2 Discharge side
- 3 Evaporator
- 4 Radial fan
- 5 Electronic expansion valve
- 6 Heat exchanger for enhanced vapour injection
- 7 Hermetically sealed Compliant scroll compressor with vapour injection (EVI)



Impressive qualities: high operational safety, reliability and low noise emissions thanks to the Compliant scroll compressor



Vitocal 350-A for indoor installation

Take advantage of these benefits

- Air/water heat pump, mono mode with a heating output from 10.6 to 18.5 kW for DHW and central heating
- Particularly suitable for modernisation through 65 °C flow temperature, even at low outside temperatures in winter
- DHW temperature subject to system version up to 55 °C
- Low running costs thanks to a high COP (COP = coefficient of performance) of up to 3.6 to EN 14511 (air 2 °C/water 35 °C)
- High efficiency all year round at any operating point and therefore low running costs through the innovative RCD (Refrigerant Cycle Diagnostic) system, with an electronic bi-flow expansion valve (EEV)
- Low operating noise through radial fan, sound-optimised appliance design and night operation with reduced fan speed
- Easy-to-use Vitotronic 200 heat pump control unit with telecontrol and remote monitoring for connection to the Vitocom 100, 200 or 300, plus cascade function for up to five heat pumps
- Installation indoors or outdoors with matching accessories
- As an option with HE pump for the heating circuit in the case of the Vitocal 350-A (indoor installation)
- Efficient defrosting through circuit reversal
- With integral energy statement

For specification, see page 65



VITOCAL 300-A

With modulating air/water heat pumps, advanced technology guarantees the highest level of efficiency in any operating state.

The energy available in the air is extremely easy to use for heating buildings and domestic hot water. It is even possible at low temperatures in winter, when the demand for heat is high. Even in these situations the Vitocal 300-A air/water heat pump runs quietly and with high efficiency.

Heating efficiently with air

The Vitocal 300-A air/water heat pump is extremely efficient and achieves high seasonal performance factors. Its output is sufficient for both central and DHW heating. This consigns fossil fuel bills to the past. Only electrical power for the heat pump system is required.

Higher convenience, lower investment

No additional investment is required to install a Vitocal 300-A air/water heat pump. There is no drilling work for geothermal probes or effort required to lay geothermal collectors. You may not need a costly buffer cylinder or cylinder loading system either, thanks to output matched to demand and optimum operation.

Finally, depending on the building structure, the Vitocal 300-A can be sited outdoors or indoors.



Energy efficiency label
Vitocal 300-A, AWCI-AC.A09



The Vitocal 300-A is certified in accordance with the EHPA Quality Label for heat pumps.



Vitocal 300-A – suitable for outdoor installation

Vitocal 300-A

3.0 to 9.0 kW

Top technology for top performance

The Vitocal 300-A is the first air/water heat pump with digital scroll technology and an electronic bi-flow expansion valve. This means it achieves an extremely high COP value (COP = coefficient of performance) of 3.9 (at air 2 °C/water 35 °C), enabling exceptionally high seasonal performance factors. What's more, this makes the Vitocal 300-A particularly reliable where heat supply is concerned yet very frugal when it comes to running costs.

RCD system for an optimum heat pump operation

RCD stands for Refrigerant Cycle Diagnostic system. It provides constant monitoring of the refrigerant circuit within the Vitocal 300-A and, in conjunction with the electronic expansion valve, ensures the highest level of efficiency at any operating point.

Not only quiet at night

Particularly quiet operation is ensured by a radial fan with variable speed control and a reduced fan speed for night operation.

Suitable for every demand

Every household has different heat demands, and the conditions for installing a heat pump also vary from case to case. Accordingly, the range of accessories for the Vitocal 300-A is suitably flexible and comprehensive. Subject to demand, the heat pump can be supplied fully equipped. This means the HE pump and 3-way diverter valve have already been fully fitted. Even the modular electric instantaneous heating water heater can be easily integrated.

Monitor and control – from wherever you are

The heat pump can simply be connected to the Vitocom 100, 200 or 300 via the control unit. The heating system can then be conveniently controlled via mobile devices.

Cooling in summer – no problem

Reversible operation turns the Vitocal 300-A into a convenient cooling system for hot summer months. Convectors or surface cooling systems with a cooling capacity of up to 9.4 kW offer the flexibility to make the temperature in living areas even more pleasant.

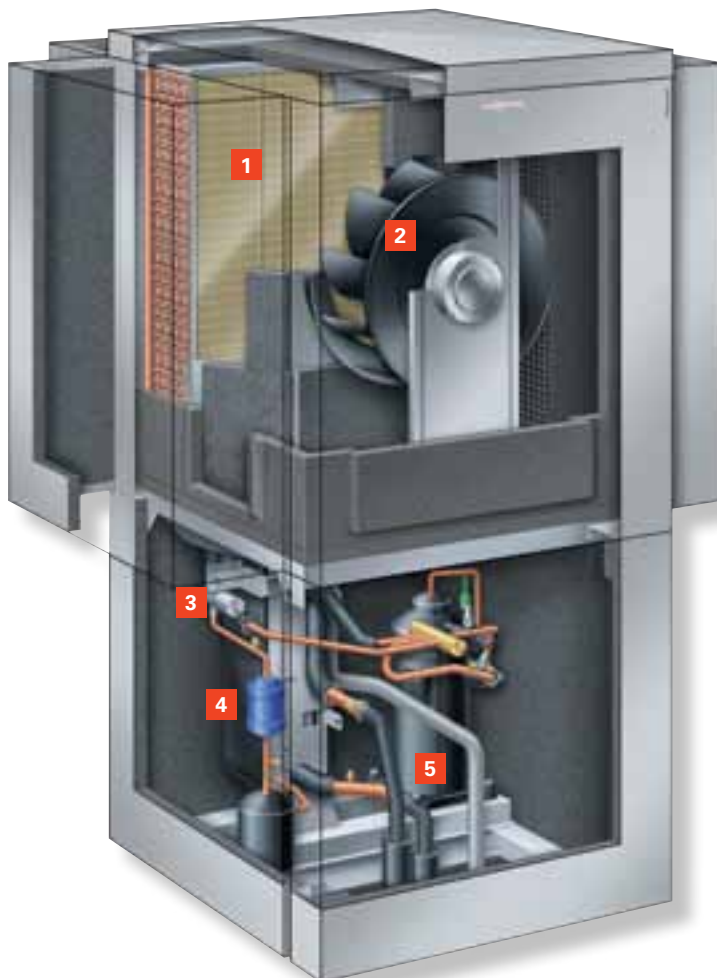

Vitocal 300-A

- 1 Evaporator
- 2 Radial fan
- 3 Electronic expansion valve
- 4 Condenser
- 5 Digital scroll compressor



The RCD system, the digital scroll technology and the electronic bi-flow expansion valve guarantee the highest level of efficiency at every operating point.

Take advantage of these benefits

- Reversible air/water heat pump for heating and cooling, for indoor or outdoor installation
- Variable output control from 3.0 to 9.0 kW
- Low running costs thanks to a high COP (COP = coefficient of performance) to EN 14511: 3.9 (air 2 °C/water 35 °C); 4.4 (air 7 °C/water 35 °C)
- Maximum flow temperature up to 60 °C at 6 °C outside temperature
- High efficiency all year round at any operating point and therefore low running costs through the innovative RCD (Refrigerant Cycle Diagnostic) system, with an electronic bi-flow expansion valve (EEV)
- Low operating noise through radial fan, sound-optimised appliance design and night operation with reduced fan speed
- Easy-to-use Vitotronic 200 heat pump control unit with telecontrol and remote monitoring for connection to the Vitocom 100, 200 or 300, plus cascade function for up to five heat pumps
- Integral HE pump for the heating circuit in the case of the Vitocal 300-A (indoor installation)
- Efficient defrosting through circuit reversal
- With integral energy statement
- Particularly quiet as silent version (with additional sound insulation set)
- Active cooling mode possible through reversible refrigerant circuit

For specification, see page 65

Heat pumps

Vitocal 300-A
Outdoor installation



VITOCAL 300-A

The Vitocal 300-A air/water heat pump uses ambient air for heating and features an attractive contemporary design.

The Vitocal 300-A air/water heat pump is characterised not only by its contemporary design. With a maximum flow temperature of 65 °C for central heating and convenient DHW heating, this appliance is particularly suitable for modernising detached and two-family houses. The Vitocal 300-A is extremely efficient and achieves high seasonal performance factors. Low electricity costs are the only running costs accrued.

Flexible and quiet

The Vitocal 300-A air/water heat pump is installed outside the building and uses free ambient air. Thanks to its variable speed DC fan, modulating compressor and sound-optimised design with sheath current air routing, the heat pump is exceptionally quiet, with a sound power level below 54 dB(A). The fan speed can also be reduced at night.



Energy efficiency label
Vitocal 300-A,
type AWO-AC 301.B11



The Vitocal 300-A meets the requirements of the EHPA Quality Label and the SG Ready label.



The Vitocal 300-A air/water heat pump received the German Design Award SPECIAL MENTION 2015 in the "Excellent Product Design – Building and Energy" category.

Vitocal 300-A

Outdoor installation

7.0 and 8.5 kW

High COP for reliable heat supply

The variable speed scroll compressor with brushless permanent magnet motor and vapour injection, as well as the electronic bi-flow expansion valve, contribute to the high COP to EN 14511 of up to 5.0 (air 7 °C/water 35 °C). Vapour injection improves efficiency, particularly at high flow temperatures. The Vitocal 300-A provides a reliable heat supply and considerably reduces operating costs, most notably in partial load operation.

Easy cooling in summer

The Vitocal 300-A is pre-set for reversible operation to provide cooling during the warmer months. When high temperatures occur in summer, convectors or surface cooling systems make the interior feel comfortably cool.

Wireless or app operation

The Vitocal 300-A is equipped with the Vitotronic 200 control unit (type WO1C). It is pre-set for wireless remote operation and allows convenient control from the living space. In conjunction with the Vitotrol app, the system can also be controlled from anywhere via a smartphone or tablet with internet connection.

Pre-set for operation with photovoltaic power and Smart Grid

Linking the Vitocal 300-A to a photovoltaic system enables further savings on running costs. The power generated on site can, for example, be used to run the Vitocal 300-A. It is also pre-set for Smart Grid (intelligent integration of consumers in power grids).

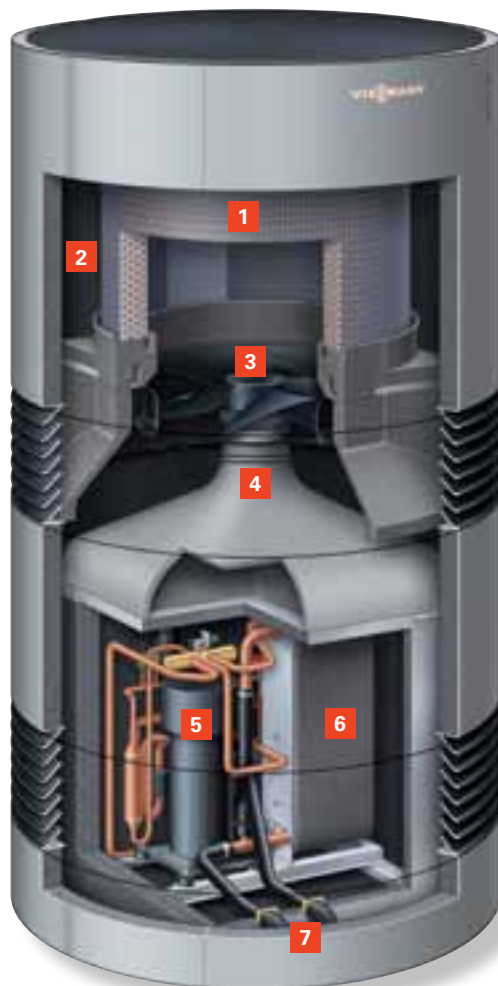

Vitocal 300-A

- 1 Coated evaporator
- 2 Sheath current air routing
- 3 Variable speed EC fan
- 4 Flow optimisation
- 5 Variable speed scroll compressor
- 6 Condenser
- 7 Hydraulic connections



The Vitocal 300-A air/water heat pump in contemporary design for outdoor installation



Vitotronic 200 weather-compensated control unit (type WO1C)

Take advantage of these benefits

- Reversible air/water heat pump for heating and cooling, for outdoor installation
- Nominal heating output: 7.0 or 8.5 kW at A2/W35
- Ideal for modernising detached and two-family houses
- Variable output control via DC inverter for high efficiency in the partial load range, and precise matching of output to heat demand
- With integral RCD (Refrigerant Cycle Diagnostic) system and electronic expansion valve to further increase efficiency at every operating point
- Low operating costs thanks to high COP to EN 14511: up to 5.0 at (A7/W35) and 3.9 at (A2/W35)
- Maximum flow temperature up to 65 °C at -5 °C outside temperature
- Low operating noise thanks to sound optimised DC fan, reduced fan speed in night mode and sound optimised appliance design
- Vitotronic 200 control unit (type WO1C)
- Optional wireless remote control and monitoring with Vitotrol app
- Pre-set for Smart Grid and optimised utilisation of power generated on site
- Contemporary design

For specification, see page 66

Heat pumps

Vitocal 242-S
Vitocal 222-S



VITOCAL 242-S

VITOCAL 222-S

Compact split air/water heat pumps for new build and modernisation, with integral DHW cylinder for a high level of DHW convenience.

Split heat pumps are characterised by separation into a quiet internal unit and an air handling external unit. This design does not require extensive wall outlets and routing of air ducts. As systems for heating only, or as systems that provide heating and cooling, these units are ideal for new build and modernisation.

The Vitocal 242-S is a split heat pump with integral solar function for solar DHW heating. The cylinder capacity is 220 litres. With the Vitocal 222-S (without solar function), the DHW cylinder holds 170 litres.

A high proportion of pre-fitted components makes these compact heating centres easy for heating contractors to install, which reduces installation costs.



Energy efficiency label
Vitocal 242-S, AWT-AC 241.A10



The Vitocal 242-S and Vitocal 222-S are certified in accordance with the EHPA Quality Label for heat pumps.

Heat pumps

Vitocal 242-S

Vitocal 222-S

3.0 to 9.0 kW

Compact internal units

With their timeless design and a width of just 60 cm, these internal units can be sited close to the living space (e.g. in the utility room). They contain hydraulic components such as a heat exchanger (condenser), DHW cylinder, HE pump, instantaneous heating water heater, 3-way diverter valve, and Vitotronic 200 control unit.

Heat pump control unit with user prompts

The Vitotronic 200 is structured logically, and its displays are easy to follow. The large backlit display offers good contrast, making it easy to read. The graphic user interface also displays heating and cooling curves.

If a solar thermal system is connected to the Vitocal 242-S, the solar yield is shown as well.

Efficient and economical

Split heat pumps operate with astonishing efficiency in partial load operation. The inverter technology accurately matches the compressor output to the current heat demand by modulating, resulting in high efficiency at every operating point.

Extensive service from Viessmann

The external and internal units are connected by the refrigerant lines on site to form a sealed refrigerant circuit. Consequently, statutes specify that installation should be carried out by qualified personnel only. Heating contractors can acquire the relevant expertise in accordance with the Chemical Safety Ordinance [Germany] as part of a one-week course at Viessmann. The system can also be commissioned by Viessmann's Technical Service department.

Vitocal 242-S Internal unit (left)

- 1 Heating lance
- 2 Enamelled DHW cylinder
- 3 Vitotronic 200 control unit
- 4 Integral solar indirect coil
- 5 Diverter valve, heating/DHW
- 6 High efficiency pump
- 7 Condenser
- 8 Integral instantaneous heating water heater

Vitocal 200-S External unit (right)

- 1 Evaporator
- 2 Fan
- 3 Compressor





Vitocal 242-S split air/water heat pump



Vitotronic 200 control unit display

Take advantage of these benefits

- Attractively priced split air/water heat pump with heating output between 3.0 and 9.0 kW (air 2 °C/water 35 °C at the nominal operating point) or 10.7 kW (air 7 °C/water 35 °C)
- Inverter compressor for optimum output matching to the heating and cooling demand
- Low running costs thanks to a high COP (COP = coefficient of performance) to EN 14511 of up to 5.1 (air 7 °C/water 35 °C) and 4.0 (air 2 °C/water 35 °C)
- Maximum flow temperature up to 55 °C at -15 °C outside temperature (with reduced output)
- High DHW convenience through integral DHW cylinder with a 220 l capacity in the case of the Vitocal 242-S (Vitocal 222-S with 170 l capacity)
- Solar connection for DHW heating with the Vitocal 242-S
- Convenient through reversible version that enables heating and cooling
- High efficiency in partial load operation through output-controlled compressor
- Low sound power level of the external unit in partial load operation through variable speed fan and compressor
- Refrigerant pipework requires no frost protection
- Easy-to-use Vitotronic 200 control unit with plain text and graphic display
- Low investment outlay
- Easy and affordable installation without major wall outlets
- Prepared for Smart Grid and utilisation of photovoltaic power generated on site

For specification, see page 66 / 67



VITOCAL 200-S

The Vitocal 200-S is ideal for new build and existing buildings. It uses the energy from ambient air and can easily be combined with existing heat generators.

Heating and cooling system with internal and external unit

The Vitocal 200-S split air/water heat pump is available either as a heating system only or as a system for heating and cooling.

The Vitocal 200-S utilises the latent heat in the outdoor air. The weather-resistant external unit can be sited where required and is easy to install, even on external walls, thanks to its compact dimensions. A freestanding installation next to the building is also possible.

As with other heating systems, the internal unit is sited in a cellar or utility room inside the building. It comprises the necessary hydraulic components, heat exchanger, HE circulation pump and 3-way diverter valve for the convenient supply of heating water and DHW. The Vitocal 200-S, type AWB-AC, also includes a three-stage instantaneous heating water heater.

In summer, the Vitocal 200-S, type AWB-AC, can also be used to cool the interior. For this, fan convectors or an underfloor heating/cooling system can be used.

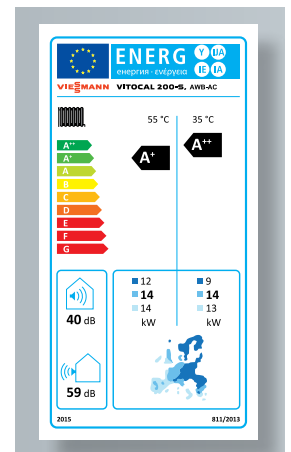

Energy efficiency label
Vitocal 200-S, AWB-AC

Schematic diagram of a heating system including Vitocal 200-S in a new build (left) and a modernisation project



The Vitocal 200-S is certified in accordance with the EHPA Quality Label for heat pumps.

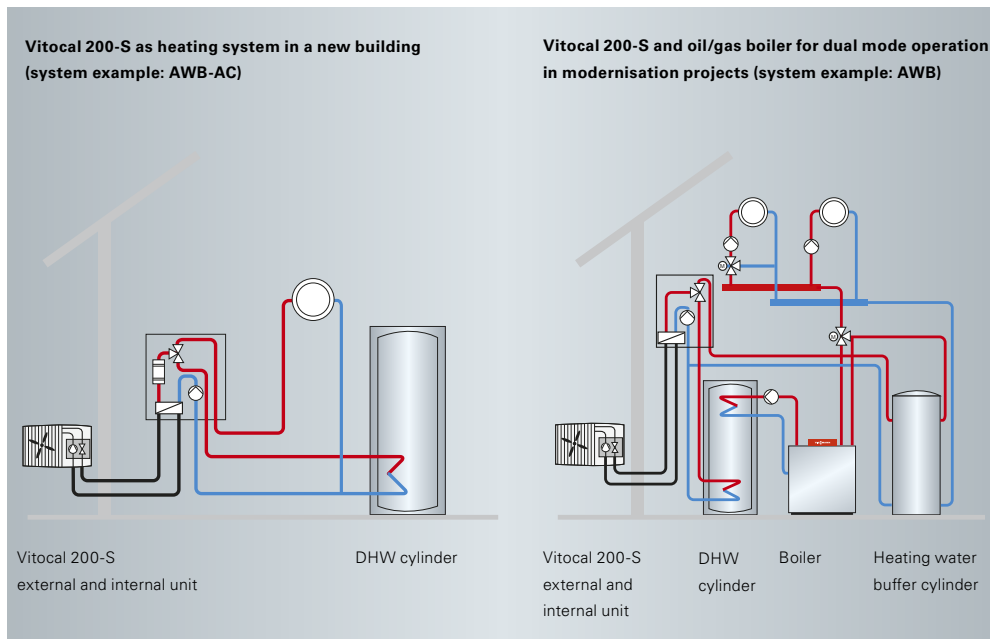

Vitocal 200-S
3.0 to 9.0 kW

Efficient and economical

The Vitocal 200-S operates with astonishing efficiency. The DC inverter adjusts the compressor performance precisely to the current heat demand by modulation and thus maintains the temperatures required for heating and cooling, plus DHW.

When it comes to modernisation, the split heat pump is ideally suited for efficient dual mode operation. In this case the existing system remains operational to cover peak loads at particularly low temperatures.

Quiet operation through variable speed control

The modulating operation of the Vitocal 200-S reduces the frequency of system starting and stopping. In addition, the variable speed fans and compressor are significantly less noisy than those that run at constant operation at top speed.

Convenient Vitotronic control unit

The control unit, with user prompts, is designed logically and is easy to follow. The large backlit display offers good contrast, making it easy to read. A help function informs users of the next steps to perform. The graphic user interface also displays heating and cooling curves.

**Vitocal 200-S
Internal unit**

- 1 Integral instantaneous heating water heater
- 2 Heat exchanger (condenser)
- 3 3-way diverter valve
- 4 High efficiency pump
- 5 Vitotronic 200



**Vitocal 200-S
External unit**

- 6 Evaporator
- 7 Fan
- 8 Compressor





Vitocal 200-S split air/water heat pump



External unit, type AWS-AC 110

Take advantage of these benefits

- Attractively priced split air/water heat pump with heating outputs between 3.0 and 9.0 kW (air 2 °C/water 35 °C at the nominal operating point)
- Low running costs thanks to a high COP (COP = coefficient of performance) to EN 14511 of up to 5.1 (air 7 °C/water 35 °C) and 3.8 (air 2 °C/water 35 °C)
- Output control and DC inverter for high efficiency in partial load operation
- Maximum flow temperature up to 55 °C at -15 °C outside temperature (with reduced output)
- Weather-resistant external unit with evaporator, compressor, expansion valve and fan
- Internal unit with HE circulation pump, heat exchanger, 3-way diverter valve, safety assembly and control unit; for heating/cooling version with integral instantaneous heating water heater
- Easy-to-use Vitotronic 200 control unit with plain text and graphic display
- Convenient thanks to reversible version that enables heating and cooling
- Optimised utilisation of power generated by a photovoltaic system on site
- COP-optimised cascade function for up to 5 heat pumps

For specification, see page 67



Vitotronic control units, with their well thought-out electronic management system, ensure the economical and safe operation of your Viessmann heating system.

Vitotronic – everything perfectly under control

With the Vitotronic control unit, operating your Viessmann heat pump is as simple as making a phone call.

Vitotronic – technology that thinks for you

Vitotronic control units provide you with every opportunity for really convenient heating, regulated to suit you personally. Once adjusted to your needs, the Vitotronic runs many functions automatically and saves a great deal of energy. Individual adjustments are simplified by the clear Vitotronic user interface with backlit keys and large display showing plain text messages.

Options for the future

The Vitotronic control unit is designed to accommodate future changes. Whether you want to build an extension in the near future, or extend your heating system by means of a solar thermal system, the Vitotronic will always keep up with the times.

Saving energy made easy

The Vitotronic automatically changes over between winter and summertime, and responds to outside temperature fluctuations as a weather-compensated control unit. There are plenty of convenience functions, such as the party button that cancels energy saving night setback or the economy and holiday programs. These can all be called up quickly and easily at the touch of a button, either on the heat pump itself, or by using the optional remote control from your living space, which has an identical user interface.

Vitocom 100 (type LAN1) operated with the Vitotrol app

The Vitotrol app for controlling the heating system is available for iOS and Android end devices. For this purpose, the standard Vitotronic must be extended by the Vitocom 100 LAN interface (type LAN1) and must be connected to the ADSL router on site. Configuration of the DSL router is not required. Messages from the boiler are sent by email to the terminal device. Up to three heating circuits can be assigned to the Vitotrol app. The app is a convenient tool for operating your heating system.



The Vitotrol 300 is a convenient remote control unit to regulate your heat pump from any room in your apartment or house.



Everything under control with the Vitotrol app – from wherever you are

Specification



Vitocal 350-G (master) single stage brine/water heat pump

Vitocal 350-G brine/water heat pump (single stage, master)*	Type	BW 351.B20	BW 351.B27	BW 351.B33	BW 351.B42
Output data (to EN 14511, B0/W35 °C, 5 K spread)					
Rated heating output	kW	20.5	28.7	32.7	42.3
Cooling capacity	kW	16.4	23.0	26.3	33.6
Power consumption	kW	4.3	5.9	6.5	8.7
Coefficient of performance ϵ in heating mode		4.8	4.9	5.0	4.8
Maximum flow temperature (5 K/12 K spread)	°C	65/70	65/70	65/70	65/70
Dimensions					
Length (depth)	mm	1085	1085	1085	1085
Width	mm	780	780	780	780
Height (with control unit open)	mm	1267	1267	1267	1267
Weight	kg	270	285	310	315
Energy efficiency class**		A++	A++	A++	A++



Vitocal 350-G heat pump as stage 2 (slave, no independent control unit)

Vitocal 350-G	Type	BWS 351.B20	BWS 351.B27	BWS 351.B33	BWS 351.B42
Output data (to EN 14511, B0/W35 °C, 5 K spread)					
Rated heating output	kW	20.5	28.7	32.7	42.3
Cooling capacity	kW	16.4	23.0	26.3	33.6
Power consumption	kW	4.3	5.9	6.5	8.7
Coefficient of performance ϵ heating mode		4.8	4.9	5.0	4.8
Maximum flow temperature (5 K/12 K spread)	°C	65/70	65/70	65/70	65/70
Dimensions					
Length (depth)	mm	1085	1085	1085	1085
Width	mm	780	780	780	780
Height (without control unit)	mm	1267	1267	1267	1267
Weight	kg	265	280	305	310
Energy efficiency class**		A++	A++	A++	A++

* Brine/water heat pump with conversion kit (accessory) to convert to water/water heat pump

** Energy efficiency class as per EU Regulation No. 811/2013 for heating, average climatic conditions – low temperature applications (W35)



Vitocal 300-G single stage brine/water heat pump

Vitocal 300-G	Type	BW 301.B06	BW 301.B08	BW 301.B10	BW 301.B13	BW 301.B17
	Type	BWC 301.B06	BWC 301.B08	BWC 301.B10	BWC 301.B13	BWC 301.B17
Output data (to EN 14511, B0/W35 °C, 5 K spread)						
Rated heating output	kW	5.69	7.64	10.36	12.99	17.24
Cooling capacity	kW	4.54	6.13	8.43	10.57	13.85
Power consumption	kW	1.24	1.62	2.07	2.60	3.65
Coefficient of performance ϵ in htg mode		4.60	4.71	5.01	5.00	4.73
Maximum flow temperature	°C	65	65	65	65	65
Dimensions						
Length (depth)	mm	844	844	844	844	844
Width	mm	600	600	600	600	600
Height (programming unit open)	mm	1155	1155	1155	1155	1155
Weight						
Type BW	kg	113	117	129	135	148
BWC type	kg	123	127	139	145	158
Energy efficiency class**		A++	A++	A++	A++	A++



Vitocal 300-G single stage water/water heat pump*

Vitocal 300-G	Type	BW 301.B06	BW 301.B08	BW 301.B10	BW 301.B13	BW 301.B17
	Type	BWC 301.B06	BWC 301.B08	BWC 301.B10	BWC 301.B13	BWC 301.B17
Output data (to EN 14511, W10/W35 °C, 5 K spread)						
Rated heating output	kW	7.51	10.18	13.51	16.89	22.59
Cooling capacity	kW	6.35	8.74	11.60	14.46	19.17
Power consumption	kW	1.24	1.55	2.05	2.61	3.68
Coefficient of performance ϵ in htg mode		6.05	6.58	6.58	6.46	6.15
Maximum flow temperature	°C	65	65	65	65	65
Dimensions						
Length (depth)	mm	844	844	844	844	844
Width	mm	600	600	600	600	600
Height (programming unit open)	mm	1155	1155	1155	1155	1155
Weight						
Type BW	kg	113	117	129	135	148
BWC type	kg	123	127	139	145	158
Energy efficiency class**		A++	A++	A++	A++	A++



Vitocal 300-G as stage 2 (slave)

Vitocal 300-G	Type	BWS 301.B06	BWS 301.B08	BWS 301.B10	BWS 301.B13	BWS 301.B17
	Output data (to EN 14511, B0/W35 °C, 5 K spread)					
Rated heating output	kW	5.69	7.64	10.36	12.99	17.24
Cooling capacity	kW	4.54	6.13	8.43	10.57	13.85
Power consumption	kW	1.24	1.62	2.07	2.80	3.65
Coefficient of performance ϵ in htg mode		4.60	4.71	5.01	5.00	4.73
Maximum flow temperature	°C	65	65	65	65	65
Dimensions						
Length (depth)	mm	844	844	844	844	844
Width	mm	600	600	600	600	600
Height (programming unit open)	mm	1155	1155	1155	1155	1155
Weight						
Type BW	kg	109	113	125	131	144
Energy efficiency class**		A++	A++	A++	A++	A++

* Brine/water heat pump with conversion kit (accessory) to convert to water/water heat pump

** Energy efficiency class as per EU Regulation No. 811/2013 for heating, average climatic conditions – low temperature applications (W35)

Specification



Vitocal 300-G single stage brine/water heat pump

Vitocal 300-G	Type	BW 301.A21	BW 301.A29	BW 301.A45
Output data (to EN 14511, B0/W35 °C, 5 K spread)				
Rated heating output	kW	21.2	28.8	42.8
Cooling capacity	kW	17.0	23.3	34.2
Power consumption	kW	4.48	5.96	9.28
Coefficient of performance ϵ in htg mode		4.73	4.83	4.6
Maximum flow temperature	°C	60	60	60
Dimensions				
Length (depth)	mm	1085	1085	1085
Width	mm	780	780	780
Height	mm	1267	1267	1267
Weight	kg	245	272	298
Energy efficiency class**		A++	A++	A++



Vitocal 300-G single stage water/water heat pump*

Vitocal 300-G	Type	BW 301.A21	BW 301.A29	BW 301.A45
Output data (to EN 14511, W10/W35 °C, 5 K spread)				
Rated heating output	kW	28.1	37.1	58.9
Cooling capacity	kW	23.7	31.4	48.9
Power consumption	kW	4.73	6.2	10.7
Coefficient of performance ϵ in htg mode		5.94	6.0	5.5
Maximum flow temperature	°C	60	60	60
Dimensions				
Length (depth)	mm	1085	1085	1085
Width	mm	780	780	780
Height	mm	1267	1267	1267
Weight	kg	245	272	298
Energy efficiency class**		A++	A++	A++



Vitocal 300-G as stage 2 (slave)

Vitocal 300-G	Type	BWS 301.A21	BWS 301.A29	BWS 301.A45
Output data (to EN 14511, B0/W35 °C, 5 K spread)				
Rated heating output	kW	21.2	28.8	42.8
Cooling capacity	kW	17.0	23.3	34.2
Power consumption	kW	4.48	5.96	9.28
Coefficient of performance ϵ in htg mode		4.73	4.83	4.6
Maximum flow temperature	°C	60	60	60
Dimensions				
Length (depth)	mm	1085	1085	1085
Width	mm	780	780	780
Height	mm	1074	1074	1074
Weight	kg	240	267	293
Energy efficiency class**		A++	A++	A++

* Brine/water heat pump with conversion kit (accessory) to convert to water/water heat pump

** Energy efficiency class as per EU Regulation No. 811/2013 for heating, average climatic conditions – low temperature applications (W35)



Vitocal 242-G ground brine/water pump

Vitocal 242-G	Type	BWT 241.A06	BWT 241.A08	BWT 241.A10
Output data (to EN 14511, B0/W35 °C, 5 K spread)				
Rated heating output	kW	5.9	7.7	10.0
Cooling capacity	kW	4.6	6.0	7.8
Power consumption	kW	1.35	1.74	2.21
Coefficient of performance ϵ in htg mode		4.5	4.5	4.5
Maximum flow temperature	°C	up to 60	up to 60	up to 60
Dimensions				
Length (depth)	mm	680	680	680
Width	mm	600	600	600
Height	mm	2075	2075	2075
Cylinder capacity	litres	220	220	220
N_g performance factor		1.5	1.5	1.6
Weight	kg	260	260	266
Energy efficiency class*		A++	A++	A++



Vitocal 222-G ground brine/water pump

Vitocal 222-G	Type	BWT 221.A06	BWT 221.A08	BWT 221.A10
Output data (to EN 14511, B0/W35 °C, 5 K spread)				
Rated heating output	kW	5.9	7.7	10.0
Cooling capacity	kW	4.6	6.0	7.8
Power consumption	kW	1.35	1.74	2.21
Coefficient of performance ϵ in htg mode		4.5	4.5	4.5
Maximum flow temperature	°C	up to 60	up to 60	up to 60
Dimensions				
Length (depth)	mm	680	680	680
Width	mm	600	600	600
Height	mm	1829	1829	1829
Cylinder capacity	litres	170	170	170
N_g performance factor		1.0	1.1	1.3
Weight	kg	250	250	256
Energy efficiency class*		A++	A++	A++



Vitocal 200-G brine/water heat pump

Vitocal 200-G	BWC type	201.A06	201.A08	201.A10
Output data (to EN 14511, B0/W35 °C, 5 K spread)				
Rated heating output	kW	5.8	7.6	9.7
Cooling capacity	kW	4.5	6.0	7.7
Power consumption	kW	1.3	1.7	2.2
Coefficient of performance ϵ in htg mode		4.3	4.4	4.4
Maximum flow temperature	°C	60	60	60
Dimensions				
Length (depth)	mm	845	845	845
Width	mm	600	600	600
Height (control unit open)	mm	1155	1155	1155
Weight	kg	113	117	129
Energy efficiency class*		A++	A++	A++

* Energy efficiency class as per EU Regulation No. 811/2013 for heating, average climatic conditions – low temperature applications (W35)

Specification



Natural cooling NC-Box

Performance data		
Cooling capacity subject to the heat pump output for Vitocal 343-G/333-G/350-G/300-G/242-G/222-G/200-G	kW	approx. 1.25–5.0
Dimensions		
Length (depth)	mm	520
Width	mm	580
Height	mm	420
Weight with mixer		kg
		28



Active cooling AC-Box

The maximum cooling capacity is limited by the integral heat pump (for Vitocal 350-G/300-G).		
Dimensions		
Length (depth)	mm	717
Width	mm	350
Height	mm	973
Weight		kg
		80

* Energy efficiency class as per EU Regulation No. 811/2013 for heating, average climatic conditions – low temperature applications (W35)



Vitocal 350-A air/water heat pump

Vitocal 350-A (indoor installation)	Type	AWHI 351.A10	AWHI 351.A14	AWHI 351.A20
Output data (to EN 14511, A2/W35 °C)				
Rated heating output	kW	10.6	14.5	18.5
Power consumption	kW	2.9	4.2	5.8
Coefficient of performance ϵ in htg mode		3.6	3.5	3.2
Maximum flow temperature	°C	up to 65	up to 65	up to 65
Dimensions				
Length (depth)	mm	946	946	946
Width	mm	880	1030	1200
Height	mm	1870	1870	1870
Weight	kg	287	297	361
Energy efficiency class*		A ⁺⁺	A ⁺	A ⁺



Vitocal 350-A air/water heat pump

Vitocal 350-A (outdoor installation)	Type	AWHO 351.A10	AWHO 351.A14	AWHO 351.A20
Output data (to EN 14511, A2/W35 °C)				
Rated heating output	kW	10.6	14.5	18.5
Power consumption	kW	2.9	4.2	5.8
Coefficient of performance ϵ in htg mode		3.6	3.5	3.2
Maximum flow temperature	°C	up to 65	up to 65	up to 65
Dimensions				
Length (depth)	mm	1265	1265	1265
Width	mm	1380	1530	1700
Height	mm	1885	1885	1885
Weight	kg	325	335	400
Energy efficiency class*		A ⁺⁺	A ⁺	A ⁺



Vitocal 300-A air/water heat pump

Vitocal 300-A	Type	AWCI-AC 301.A09 Indoor installation	AWO-AC 301.A09 Outdoor installation	AWO-AC 301.A09 Outdoor installation (silent version)
Output data (to EN 14511, A2/W35 °C)				
Rated heating output	kW	3 – 9	3 – 9	3 – 9
Power consumption	kW	2.31	2.31	2.31
Coefficient of performance ϵ in htg mode		3.9	3.9	3.9
Cooling capacity at A27/W7 °C	kW	8.6	8.6	8.6
Maximum flow temperature	°C	up to 60	up to 60	up to 60
Dimensions				
Length (depth)	mm	946	946	1265
Width	mm	880	880	1380
Height	mm	1870	1885	1885
Weight	kg	289	279	309
Energy efficiency class*		A ⁺⁺	A ⁺⁺	A ⁺⁺



* Energy efficiency class as per EU Regulation No. 811/2013 for heating, average climatic conditions – low temperature applications (W35)

Specification



Vitocal 300-A air/water heat pump

Vitocal 300-A	Type	AWO-AC 301.B11	AWO-AC 301.B14
Output data			
Rated heating output			
Operating point A2/W35 (to EN 14511)	kW	7.0	8.5
Operating point A-7/W35 (to EN 14511)	kW	10.5	12.0
Coefficient of performance ϵ A2/W35		3.9	3.9
Coefficient of performance ϵ A7/W35		5.0	5.0
Rated cooling capacity			
Operating point A35/W18 (to EN 14511)	kW	8.1	9.0
Maximum flow temperature	°C	up to 65	up to 65
Sound power level			
Min./max./night mode	dB(A)	49/53/51	50/54/52
Operating point A7/W55			
Dimensions			
Length (depth)	mm	1100	1100
Width	mm	1100	1100
Height	mm	1980	1980
Weight	kg	250	250
Energy efficiency class*		A++	A++

* Energy efficiency class as per EU Regulation No. 811/2013 for heating, average climatic conditions – low temperature applications (W35)



Vitocal 242-S split compact air/water heat pump

Vitocal 242-S, type AWT-AC		241.A04	241.A05	241.A07	241.A10
Heating output data (to EN 14511, A2/W35 °C)					
Rated heating output	kW	3.0	3.43	5.6	7.7
Coefficient of perf. ϵ in htg mode		3.27	4.05	3.24	3.50
Output control	kW	1.1 – 3.8	1.3 – 6.5	1.3 – 7.7	4.4 – 9.9
Cooling capacity data (to EN 14511, A35/W7 °C, 5 K spread)					
Rated cooling capacity	kW	3.2	4.2	6.2	7.4
Energy efficiency ratio ϵ in cooling mode		2.96	3.1	2.58	2.58
Output control	kW	1.2 – 3.8	1.6 – 7.0	1.6 – 8.0	2.4 – 8.5
Cylinder capacity	litres	220	220	220	220
Dimensions, internal unit					
Length (depth) x width x height	mm	680 x 600 x 2075			
Dimensions, external unit					
Length (depth)	mm	290	340	340	340
Width	mm	869	1040	1040	975
Height	mm	610	865	865	1255
Weight					
Vitocal 242-S internal unit	kg	204	204	204	207
Vitocal 222-S internal unit	kg	194	194	194	194
External unit	kg	43	66	66	110
Energy efficiency class*		A++ / A+	A++ / A+	A++ / A+	A++ / A++
DHW heating:					
Draw-off profile	L	L	L	L	XL
Energy efficiency class	A	A	A	A	A

* Energy efficiency class as per EU Regulation No. 811/2013 for heating, average climatic conditions – medium temperature applications (W55)



Vitocal 222-S split air/water heat pump compact appliance

Vitocal 222-S, type AWT-AC		221.A04	221.A05	221.A07	221.A10
Heating output data (to EN 14511, A2/W35 °C)					
Rated heating output	kW	3.0	3.43	5.6	7.7
Coefficient of performance ϵ htg mode		3.27	4.05	3.24	3.50
Output control	kW	1.1 – 3.8	1.3 – 6.5	1.3 – 7.7	4.4 – 9.9
Cooling capacity data (to EN 14511, A35/W7 °C, 5 K spread)					
Rated cooling capacity	kW	3.2	4.2	6.2	7.4
Energy efficiency ratio ϵ in cooling mode		2.96	3.1	2.58	2.58
Output control	kW	1.2 – 3.8	1.6 – 7.0	1.6 – 8.0	2.4 – 8.5
Vitocal 222-S cylinder capacity	litres	170	170	170	170
Dimensions, internal unit					
Length (depth) x width x height	mm	680 x 600 x 1829			
Dimensions, external unit					
Length (depth)	mm	290	340	340	340
Width	mm	869	1040	1040	975
Height	mm	610	865	865	1255
Weight					
Vitocal 242-S internal unit	kg	204	204	204	207
Vitocal 222-S internal unit	kg	194	194	194	194
External unit	kg	43	66	66	110
Energy efficiency class*		A** / A+	A** / A+	A** / A+	A** / A**
DHW heating:					
Draw-off profile		L	L	L	XL
Energy efficiency class		A	A	A	A



Vitocal 200-S split air/water heat pump

Vitocal 200-S		201.B04	201.B05	201.B07	201.B10
Type AWB/AWB-AC					
Heating output data to EN 14511 (A2/W35 °C)					
Rated heating output	kW	3.0	4.05	5.6	7.7
Coefficient of performance ϵ in htg mode		3.30	3.43	3.24	3.50
Output control	kW	1.1 – 3.8	1.3 – 6.5	1.3 – 7.7	4.4 – 9.9
Heating output data to EN 14511 (A7/W35 °C, 5 K spread)					
Rated heating output	kW	4.5	5.04	8.39	10.90
Coefficient of performance ϵ in htg mode		4.64	4.46	4.28	4.62
Cooling capacity data to EN 14511 (A35/W7 °C, 5 K spread)					
Rated cooling capacity	kW	3.20	4.20	6.20	7.40
Energy efficiency ratio ϵ in cooling mode		2.96	3.10	2.58	2.75
Output control	kW	1.2 – 3.8	1.6 – 7.0	1.6 – 8.0	1.6 – 8.0
Cooling capacity data to EN 14511 (A35/W18 °C, spread 5 K)					
Rated cooling capacity	kW	4.20	6.90	8.80	10.00
Energy efficiency ratio ϵ in cooling mode		3.72	3.80	3.35	3.57
Dimensions, external unit					
Total length (depth)	mm	290	340	340	340
Total width	mm	869	1040	1040	975
Total height	mm	610	865	865	1255
Dimensions, internal unit					
Total length (depth)	mm	360	360	360	360
Total width	mm	450	450	450	450
Total height	mm	905	905	905	905
Total weight					
External unit	kg	43	66	66	110
Internal unit AWB	kg	34	34	34	37
Internal unit AWB-AC	kg	38	38	38	42
Energy efficiency class*		A**/A+	A**/A+	A**/A+	A**/A**

* Energy efficiency class as per EU regulation No. 811/2013 for heating, average climatic conditions – low (35 °C) / medium temperature applications (55 °C)



Brooke Veterinary surgery, Norwich
Vitocal 300-G ground source heat
pump



HUF HAUS show house, London,
Vitofriocal ice store

Heat pump systems in operation

Advanced and energy efficient reference systems

Heat pump systems

Heat pumps from Viessmann offer tailor-made solutions for central heating and convenient hot water supply, both for new build and modernisation projects. The active and natural cooling functions create a pleasant interior in the summer as well as the winter. Advanced heat pump systems are fully integrated and equipped with safety devices for reliable, efficient and safe operation.



Gatton Barn Farm, Parbold, Wigan

This award winning site had previously been an open farm with no insulation or heating system. A total refurbishment in 2013 saw it become a living area, care facility and home to the four members of the Davies family. Two 14 kW Vitocal 350-A air source heat pumps were installed to cover the heating and hot water demand of the main house and lodge, which also integrate with Vitosol 300-T solar thermal tubes and additional PV panels for complete system efficiency. Compared to an oil fired system, this renewable technology mix is saving over £5,700 per year for the family in addition to funding from the renewable heat incentive.



Mill House, Farnham, Hampshire

When the owner of a former corn mill wanted to generate electricity from his on-site stream, a Viessmann-trained installer recommended a unique combination of an Archimedes screw, Vitocal 300-G ground source heat pump and buffer cylinder. In what is the first project of its kind in the UK, the customer is now saving over £22,000 per year in energy bills. The Vitocal 300-G heat pump system was specified in a master and slave configuration, with a buffer cylinder to cut running costs. The system extracts heat from the nearby stream via a submersible river heat exchanger with five stainless steel plates. This provides under floor and radiator heating and a base load of hot water for the main house; there is immersion top up for a granary extension.



Domestic property, Ilfracombe, Devon

When others in the local community started to experience the benefits of renewable heating, homeowner Mr Jenkinson wanted to know more. After contacting a Viessmann trained installer, an energy system comprising of three different technologies; solar thermal, solar PV and a split air source heat pump was installed in the four bedroom family home. The Vitocal 242-S split heat pump provides space heating for the property, while solar thermal tubes cater for the hot water. The system is governed by Vitotronic 200 controls, which integrates each technology and saves Mr Jenkinson £1,500 per year in energy bills.

The company



Viessmann – climate of innovation

Viessmann is one of the world's leading manufacturers of intelligent, convenient and efficient systems for heating, cooling and decentralised power generation.

As a third generation family run business, Viessmann has been supplying highly efficient and clean heating systems for many decades.

A strong brand creates trust

Together with our brand label, our key brand message is an identifying feature throughout the world. "Climate of innovation" is a promise on three levels: It is a commitment to a culture of innovation. It is also a promise of enhanced product benefits and, at the same time, an obligation to protect the environment.

Acting in a sustainable manner

For Viessmann, taking responsibility signifies a commitment to acting sustainably.

This means harmonising ecology, economic concerns and social responsibility so that

the needs of today are met without compromising the quality of life of future generations.

We consider climate protection, environmental responsibility and resource efficiency to be key priorities throughout our company, which has more than 11,500 employees worldwide.

Example of Best Practice

With its strategic sustainability project, Viessmann demonstrates at its own head office in Allendorf (Eder) that the energy and climate policy goals set for 2050 can in fact be achieved today with commercially available technology. The results speak for themselves:

- Expansion of renewables to 60 percent
- CO₂ emissions reduced by 80 percent

The long term goal is for the company to meet all its own heating energy requirements by sustainable means.



2009/2011/2013:
German Sustainability Award
for Production/Brand/Resource
Efficiency



Energy Efficiency Award 2010

Viessmann Group

Company details

- Established in: 1917
- Employees: 11,500
- Group turnover: 2.2 billion euros
- Export share: 56 percent
- 22 production companies in 11 countries
- 74 countries with sales companies and branches
- 120 sales offices worldwide

The comprehensive product range from the Viessmann Group for all energy sources and output ranges

- Boilers for oil or gas
- Combined heat and power generation
- Hybrid appliances
- Heat pumps
- Wood combustion technology
- Biogas production plants
- Biogas upgrading plants
- Solar thermal
- Photovoltaics
- Accessories
- Refrigeration systems



climate of innovation

Viessmann Limited
Hortonwood 30, Telford
Shropshire, TF1 7YP
Tel: 01952 675000
Fax: 01952 675040
www.viessmann.co.uk

Your trade partner:

9440 090 GB 11/2015

Copyright Viessmann
Duplication and alternative use only with prior written consent.
Subject to technical modifications.