

Method Statement

MaxAtec 150 - A01/A02

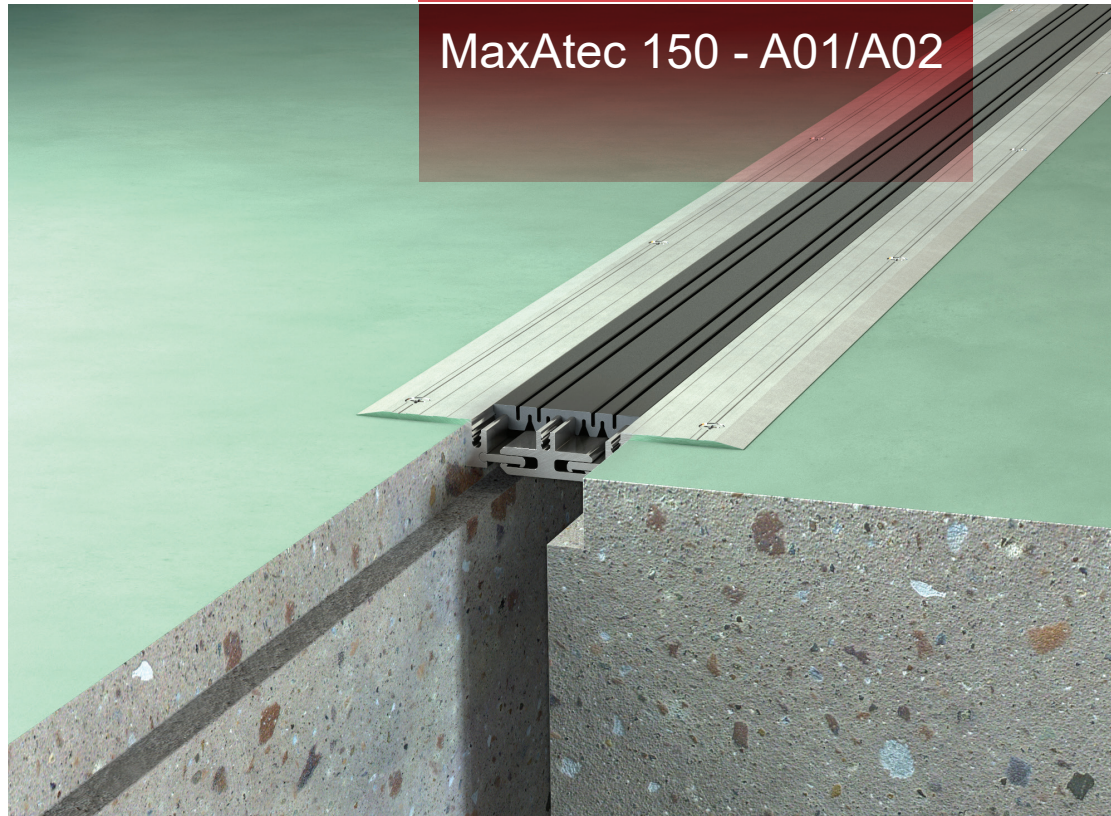

Contents

Content	Page No.
Assembly Components	2
Fitting Hardware	2
Before You Start	2-3
Preparation	3
Rebate/ Levelling Bed - If joint needed	4-5
Joint Installation	6-8
Protection	9
Aftercare	9



Assembly Contents :

A01/A02

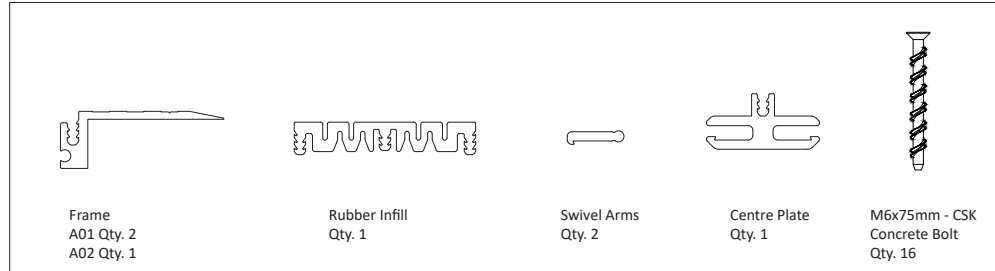

A02

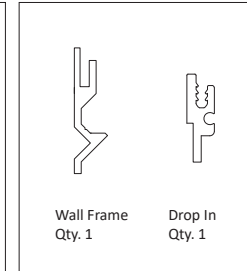

Fitting Hardware :

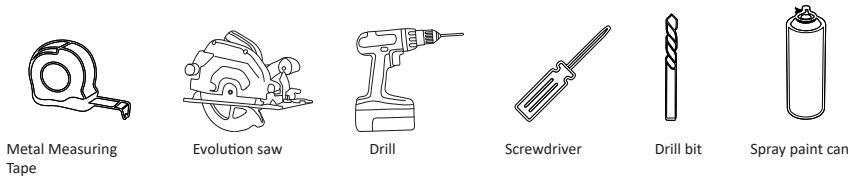

Before You Start :

- Remove joint components from the packaging taking care not to damage exposed surfaces of the profile material.
- Verify that structural gap and block out dimensions are in conformance with submittal data prior to commencing work.

Product Details

Product Number	Sightline A (mm)	Blockout C (mm)
150-A01-025	189	70
150-A01-050	206	87
150-A01-075	230	111
150-A01-100	255	136
150-A02-025	179	70
150-A02-050	196	77
150-A02-075	220	101
150-A02-100	245	126

Maxatec 150 : A01

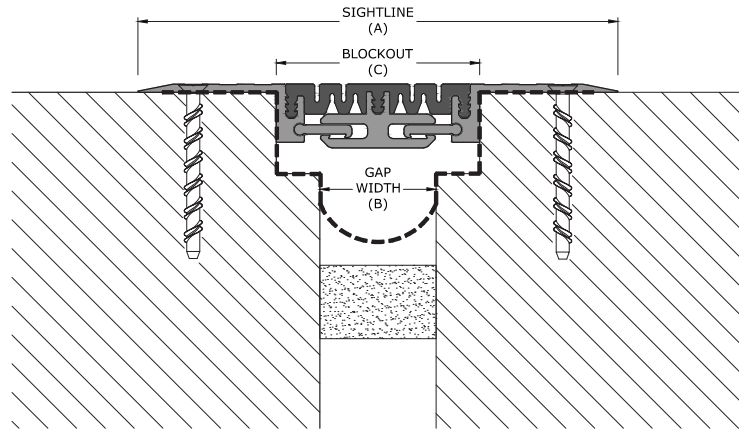

Maxatec 150 : A02

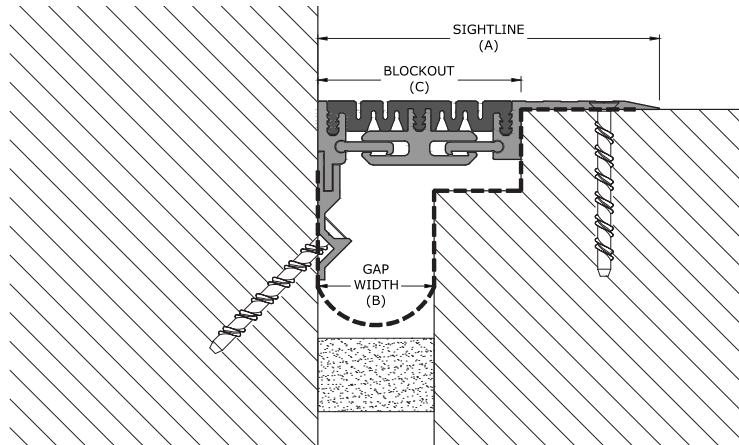

Preparation :

- Ensure that the floor is flat and levelled and debris free.
- The fire barrier and waterproofing membrane must be installed in the structural gap before the architectural joint system. Refer to separate method statement.
- If Waterproofing has been fitted, apply gun-applied resin anchor to each hole. Refer to separate Method Statement.

Rebate : If required for joint

Surface Mounted Rebate

- A rebate may be required in the concrete to allow for the overall width of the blockout of the profile. The width of the rebate must be square to allow for the joint to fit the required width, do not make the rebate bigger than the blockout dimension.
- The rebate must be the full depth of the height of the profile, plus 5-10mm for tolerance.

Floor-Floor

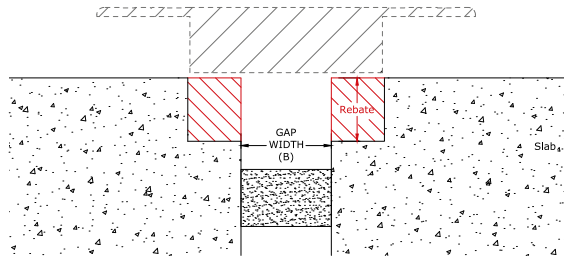

Floor - Wall

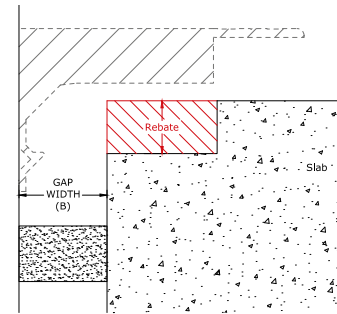

Depth Allowance Rebate

- The depth allowance rebate is required when you do not have enough space within the finishes zone for a standard joint detail.
- A rebate must be made into the concrete slab at the depth of the frame height plus a minimum of 10mm levelling bed minus the floor finish depth.

Floor-Floor

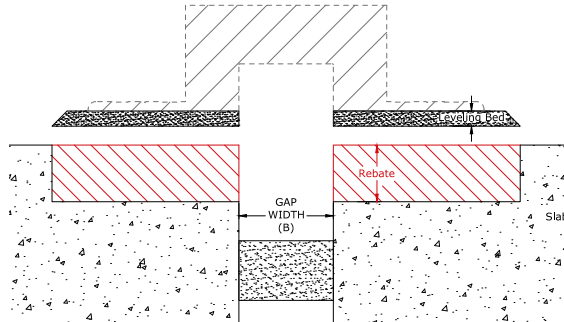

Floor - Wall

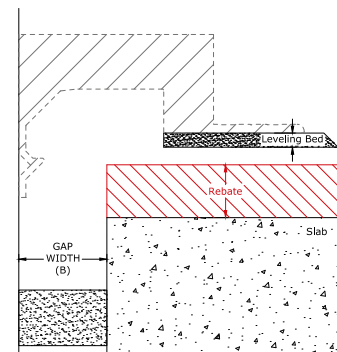

Levelling Bed : If required for joint

- Install High Strength mortar levelling bed to achieve a minimum 40N/mm² compressive strength. Minimum depth of Levelling Bed as required by manufacturers Technical Data information.
- Distance from top of Levelling Bed to Finish Floor Level must be equal to the Frame Height.
- If necessary adjust levelling bed to accommodate fire barrier and waterproofing.
- Ensure Levelling Bed is continuous along the full length of the structural gap and is consistent in height.
- Levelling bed width should be no less than Blockout width (C).
- Calculate correct levelling bed depth:
Levelling Bed + Frame Height = X
- Ensure the Levelling Bed has fully cured before drilling and fixing the Frames.

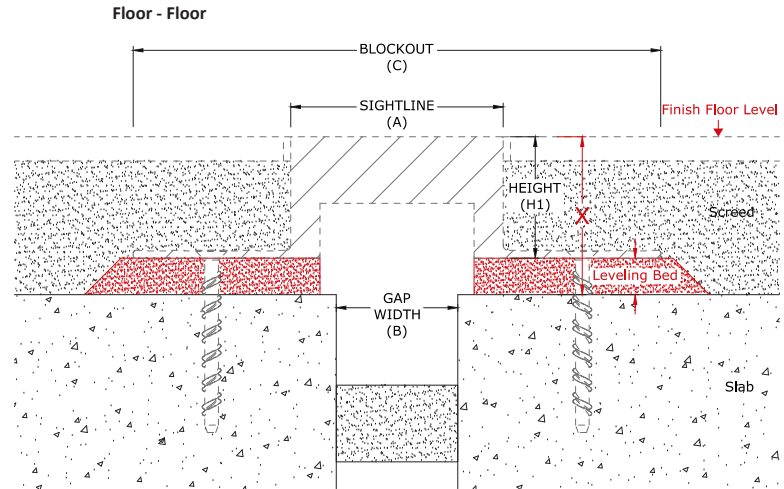

Joint Installation :

Components

- | | |
|------------------|---------------------------------|
| (1) Frame | (5) Drop In |
| (2) Wall Frame | (6) Rubber Infill |
| (3) Centre Plate | (7) M6x75mm - CSK Concrete Bolt |
| (4) Swivel Arms | |

Maxatec 150 : A01

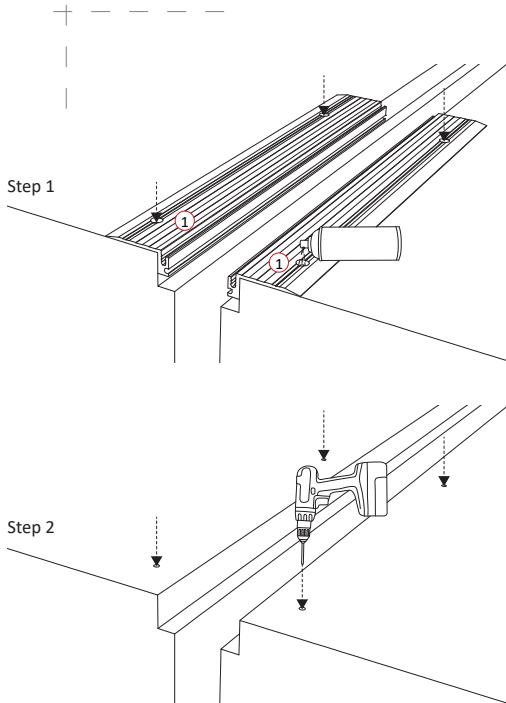

- Place the frames on the surface at the width of the blockout.
- Mark the holes through the predrilled holes in the frames with spray paint or similar.

- Remove the frames and drill the holes into the surface using a 6mm drill at a depth of 80mm.

Maxatec 150 : A02

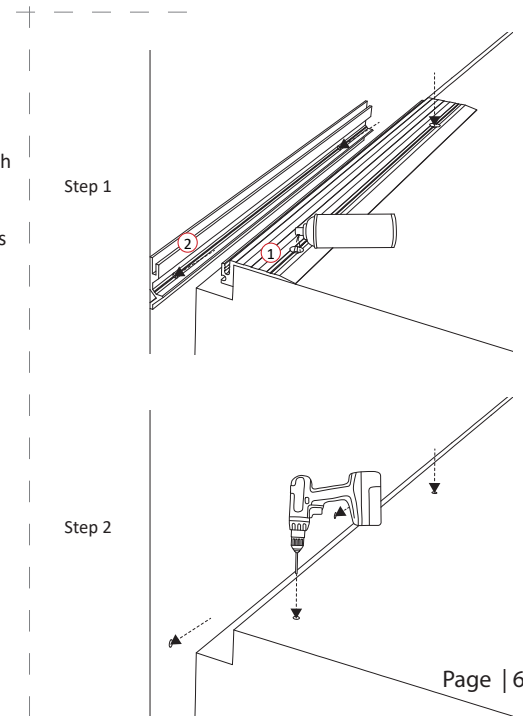

Step 3

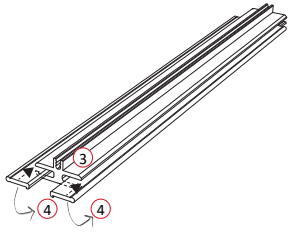

- Slide swivel arms into centre support.
- Replace the wall frames back upon the wall, fix the frames into place with the M6x75mm concrete screws and tightening at a torque of 25Nm.

Step 3

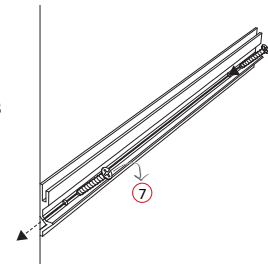

Step 4

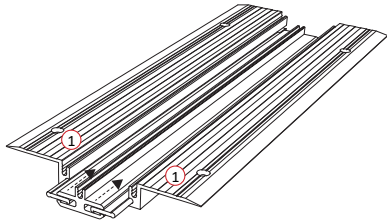

- Slide centre components (swivel arms and centre support) into frames.

Step 4

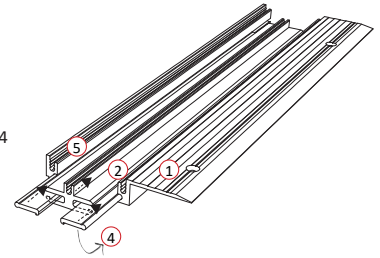

Step 5

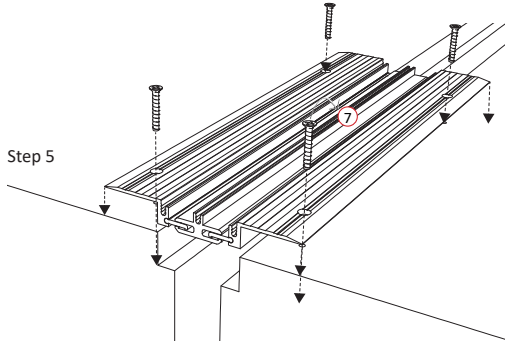

- Place the assembled joint upon the surface, fix the frames into place with the M6x75mm concrete screws and tightening at a torque of 25Nm.

Step 5

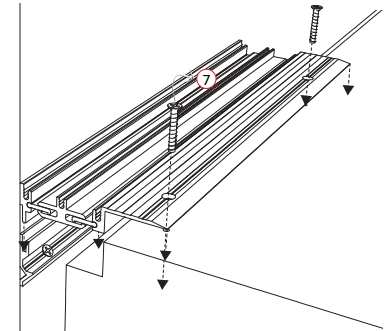

Method Statement

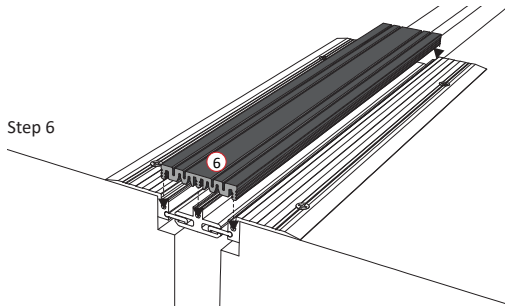

- Insert the rubber infill into the frames, warm soapy water or a roller maybe required to ease the process.

(At this point install the secondary layer of waterproofing on to the joint, lapping onto the frames. If applicable.)

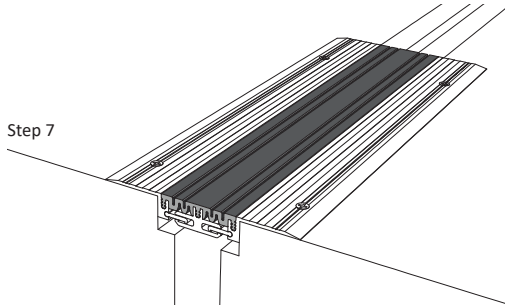

- The expansion joint system has now been successfully installed. Clean exposed surfaces with non-solvent cleaner as required.

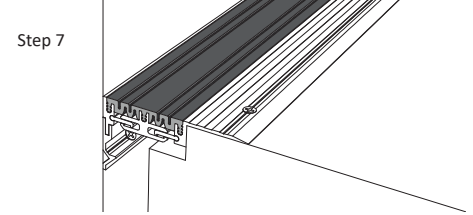
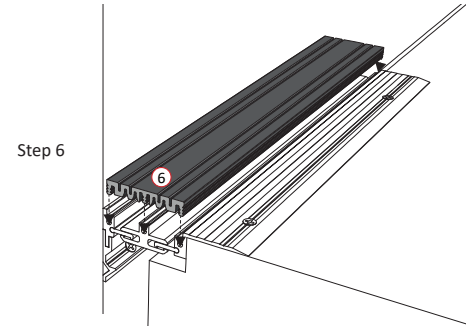

Joining Lengths Together

- Ensure ends are squared off to allow joints to lay flush next to each other.
- Heat bond the length of rubber together for a watertight seal, using a Teflon coated plate.
- Intersection joints - Refer to intersection method statement.
- Measure and neatly cut to length, using a metal chop saw with aluminium cutting saw blade, minimum of 12000 RPM.

Protection :

- We recommend the joint is protected at all times from site traffic, prior to handover.
- Leave tape on until surface side of joint is ready to be exposed to avoid scratches and unwanted marks.

After Care :

Cleaning & Maintenance Instructions:

- All joints should be cleaned using a mild detergent.
- Abrasive cleaning regimes should be avoided as this could, over time, cause damage to the joint.

Please do not hesitate to call or email Vexcolt for your enquiries.

T : +44 (0) 20 8194 5999

W : www.vexcolt.com

Sales

E : info@vexcolt.com

Technical

E : technical@vexcolt.com