

Solid Surface Vanity

We know washrooms

Installation Instructions

Recommendations for Solid Grade Laminate (SGL)

Machining

- Use tungsten carbide tipped blades/cutters or metal cutting tools.

Cutting

- For a clean cut, use carbide tipped saw blades with trapezoidal & as many teeth as possible or jigsaw with metal cutting blade.
- Alternating teeth may be suitable, but the cut will not be as clean.
- For best results, use horizontally fixed saws.

Precision Cutting

- A clean edge without flaking can be obtained.
- For best quality cut:
 1. Saw the panel slightly oversize
 2. Re-cut edge to precise measurement using a tungsten carbide tipped router cutter of required profile at 18,000 to 22,000 rpm.

Grooving

- SGL can be grooved; use a saw blade or router cutter with tungsten carbide tips.
- Groove depth must not exceed 1/3 of SGL thickness.

Drilling

- For best results use carbide bits with 3 prongs (helicoïdal bits) in preference to high-speed steel drills.
- Holes can be drilled through part or whole of thickness
- For stopped holes, minimum thickness of 1.5mm to 2mm of laminate must remain (maximum depth of hole = 11mm). Minimum of 1mm space must remain between tenon, screw tip or insert & bottom of hole (otherwise, risk of laminate cracking when fitting)
- Pilot hole diameters for screw fixing to SGL to be 0.5mm less than diameter of screw.

- Generally;
- No 6 screw - 3.5mm
 - No 8 screw - 4mm
 - No 10 screw - 4.5mm
 - No 12 screw - 5mm

- ALL pilot hole diameters should be screw tested before finalising.

Cut-Outs

- Square cut-outs:

Drill four corners (at least a 10mm diameter hole), start from one of the holes, use a jigsaw with metal cutting blade, cut the holes & square into the corners. Finish with metal file (semi-soft), ensure all sharp arrises are removed to avoid injury.

- Oval or circular cut-outs:

E.g, cutting a basin hole into a vanity top. Drill one 10mm diameter hole, start from the hole, cut according to template, use a jigsaw with metal cutting blade. Finish with metal file (semi-soft), ensure all sharp arrises are removed to avoid injury.

Resizing & re-edging previously finished panels

- We recommend the panel is cut as previously described, trim to size using a 'TREND' sunk bead router cutter running at 18,000 to 22,000 rpm, finish with 300 grit sand paper.
- Polish as described below.

Finish edges

- To eliminate machine-cutting imperfections at edges, sand with 300 grit sand paper to fine finish.
- To obtain darker edges, rub edge with cloth soaked in linseed oil or wax. Leave to dry for 30 minutes & wipe off.
- Sharp edges must be smoothed to avoid injury.

Recommendations for Solid Surface

Do NOT screw directly into Solid Surface material, secure only by means of factory fitted substrate. If additional framing is required then this should be fixed to the Solid Surface with flexible silicone sealant.

Preparation

- Before fabrication it is recommended that all Solid Surface work tops are brought to a minimum temperature of 60°F/15°C.
- When working with Solid Surface, please ensure that safety glasses and a particle mask are worn at all times.
- All sanding should be done in a well ventilated area.

Machining

- Solid Surface can be machined with ordinary woodworking tools, however all blades and bits should be carbide tipped.

Cutting

- In order to obtain a clean cut, we suggest the use of a triple cut bevel saw blade.
- These saws require a 10" diameter blade with 60 teeth and 5° positive hook.

Routing

- For general purpose routing, a 1.5-2HP router may be used.
- For heavier cutting of thick edges and cut outs a 3HP router is recommended.
- A ½" shank carbide bit is needed to minimise the chatter for all routing with exception of small details like a ¼" round over.

Cut-Outs

- Use a template and router for all Solid Surface cut outs.
- The use of a jigsaw can leave rough edges where stress cracks can occur.

Finishing Edges

- In order to eliminate machine-cutting imperfections created at edges, use a high quality router and reasonable feed speed.
- A variety of cuts/finishes can then be achieved.
- Sharp edges must be smoothed to avoid injury.

Restoring Solid Surface

- For the occasional abusive stain or heavy burn, scrubbing with an abrasive cleaner will restore Solid Surface tops to their original lustre.
- Strong industrial and some household chemicals (e.g, paint removers and drain cleaners) can cause damage.
- Wiping up the spill immediately and flushing with water may avoid damage.
- A knife cut, scratch or gouge can be repaired by sanding the blemish with 240 grit sandpaper, followed by 400grit paper and a final polish with an abrasive cleaner or green Scotch-Brite pad until the damage has disappeared completely.

Introduction

Safety

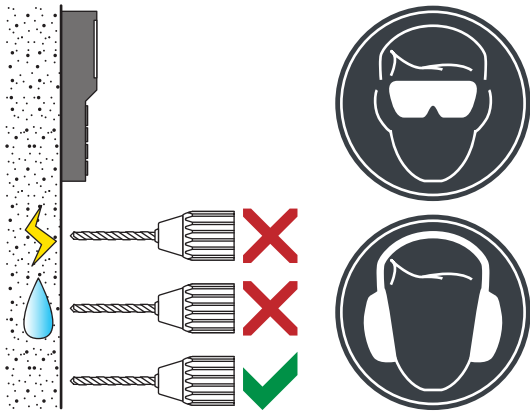

Panel Storage & Conditioning

- To ensure panels and doors remain flat ambient site conditions must be stable prior to delivery. Variable temperature and humidity can cause panels to bow and twist irreversibly.
- Before, during and after installation, temperature and humidity must be maintained between 18 - 25°C.
- Panels should not be stored outside or in areas where they may be exposed to water or humidity.
- Wet trades and forced-drying procedures should be complete and the building fully dried out.
- Use supports and spacers to elevate panels off the floor and keep space between panels; air must be able to circulate around each panel evenly.
- The ideal base is a slatted pallet with base board; however, if these are not available, panels should be carefully stacked on bearers suitably spaced to maintain flatness. Spacing of bearers should not exceed 400mm.
- Avoid storage conditions where extremes of temperature and humidity can occur.
- Panels must be allowed to equalise to levels approximating to those that will prevail during building use.
- BS EN438 recommendations should be adhered to:

Temperature – 18 to 25°C

Air humidity – 40 to 60%

BS 4965 Flatness: Flatness to BS 4965 can only be guaranteed at the time of delivery.

Toolbox

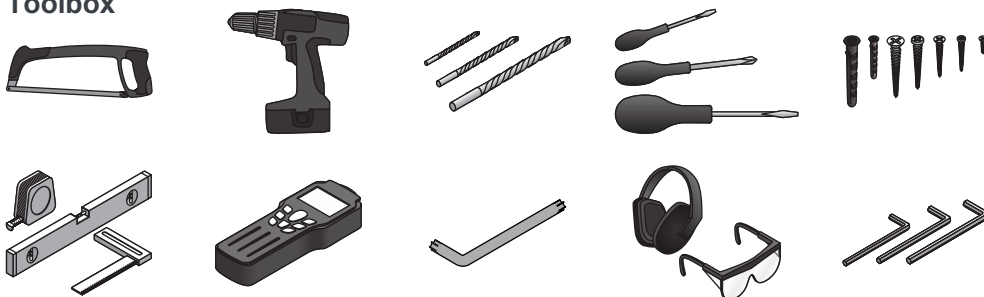

Prerequisites

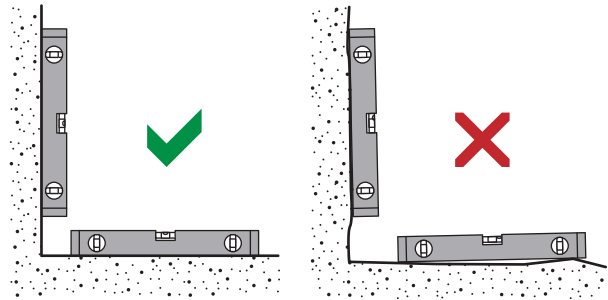

Secure Fixing

It is vital that the structural integrity of walls, ceilings and floors is capable of taking the dynamic and static loads imposed by the fixings to support the product. Insufficient structural integrity will invalidate guarantees.

The surfaces being fixed into should be firm and stable, without deflection and have good fixing retention properties over the length and width of the bearing surface.

Particular care should be taken with studwork walls and suspended ceilings which will usually require the inclusion of a pattress to sufficiently strengthen the structure.

Poor security of fixings will compromise performance and could lead to failure of the vanity units, cubicle or duct systems.

Screws and Fixings supplied to fix components to the floor or wall structural material should be tested to ensure they are suited and have sufficient holding power to accept the static and dynamic loads required to support our products. Due to the multitude of floor and wall constructions, it should not be assumed that the fixings supplied are suitable for all installations. If you are uncertain contact your local specialist fastening supplier.

Do NOT overtighten fasteners, if using power drivers make sure that the torque settings are correct.

Cleaning & Maintenance

Please consult our cleaning & maintenance guide.

1 Layout & Levelling



- Installers should be highly experienced and be qualified to a carpentry joiner level.
- Before installation, if in any doubt about how to install these products please contact our technical department.
- **PPE:** Wear personal protection equipment at all times.
- **Unit Dimensions:** Refer to layout drawings +/- 5mm.
- **It is the installer's responsibility to ensure that framing is adequately fixed.**

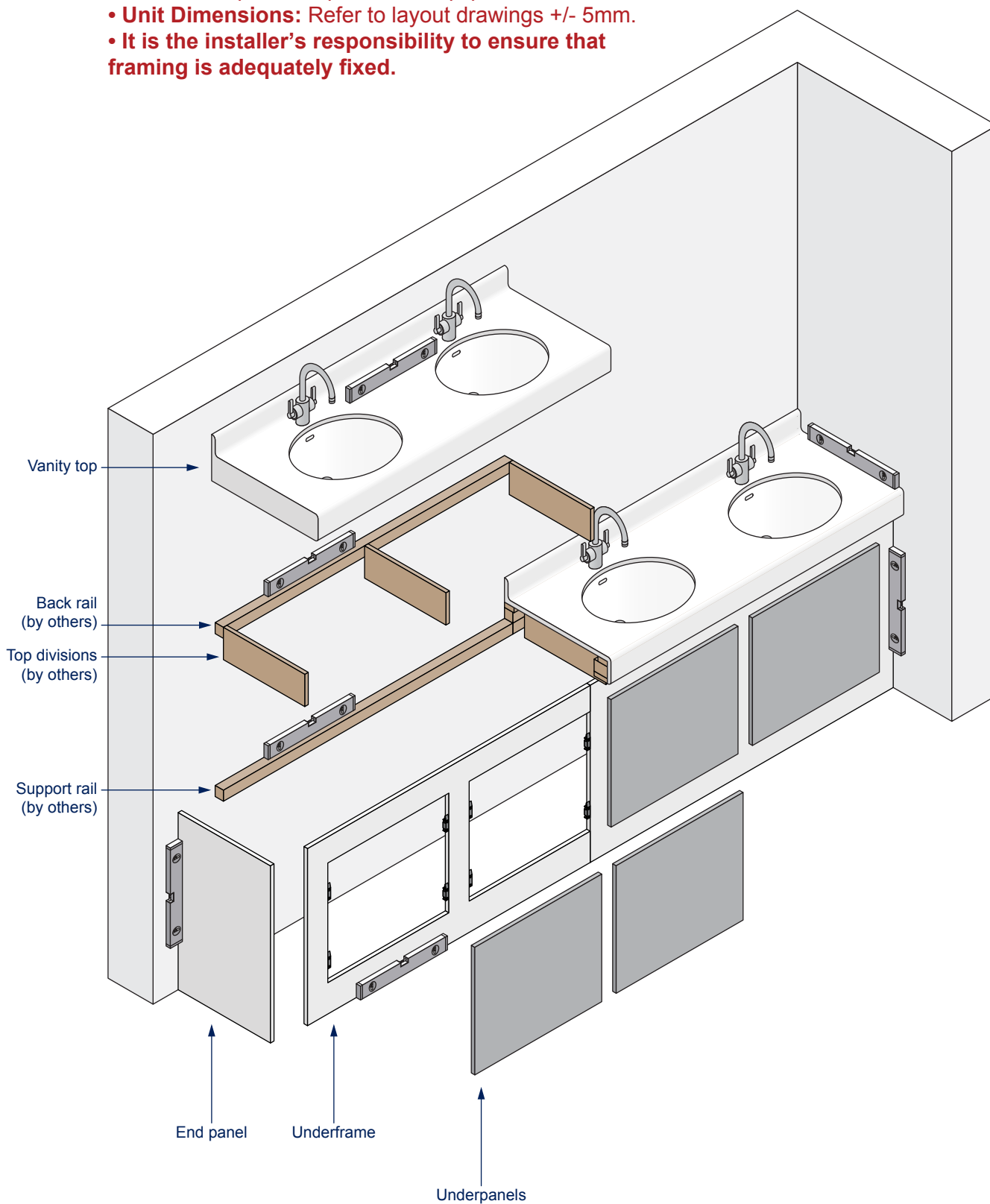

PLEASE NOTE: when applying adhesive or silicone, ensure any surplus that bleeds out to the seen surfaces is immediately removed with an appropriate cleaner so that no residue is left.

2 Support Rail Fixing

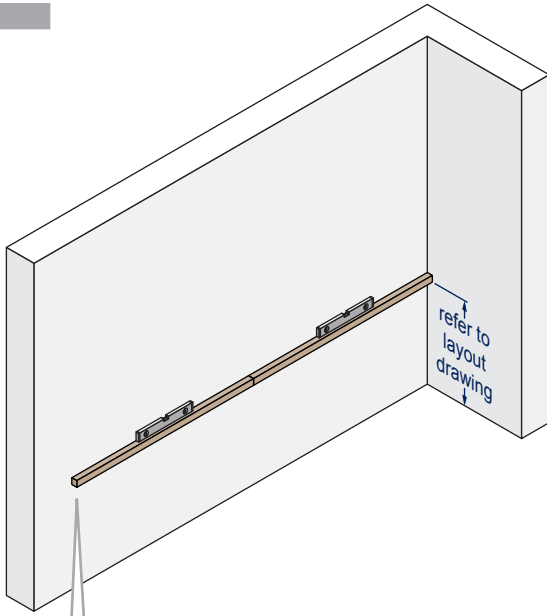

1

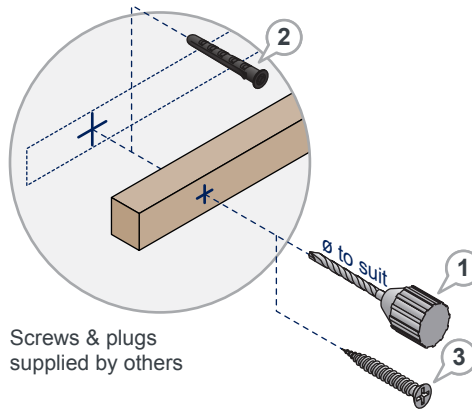
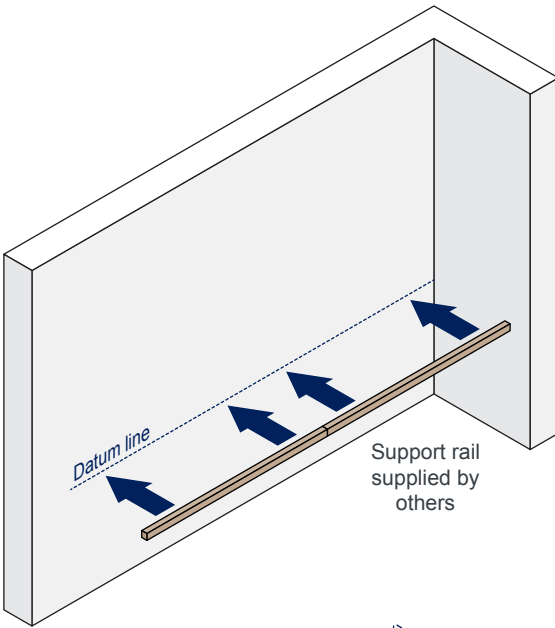

Fully Inset Vanity Top:

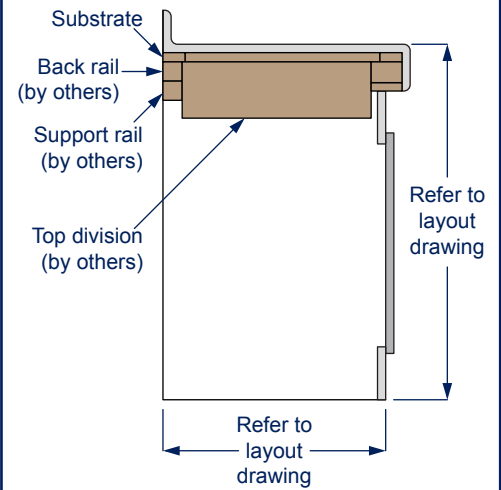

Semi-Recessed Vanity Top:

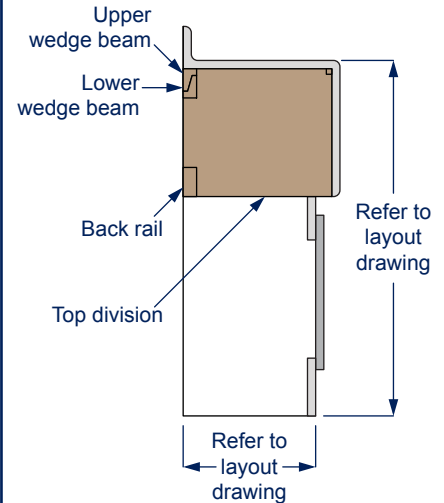

3 Underframe Preparation

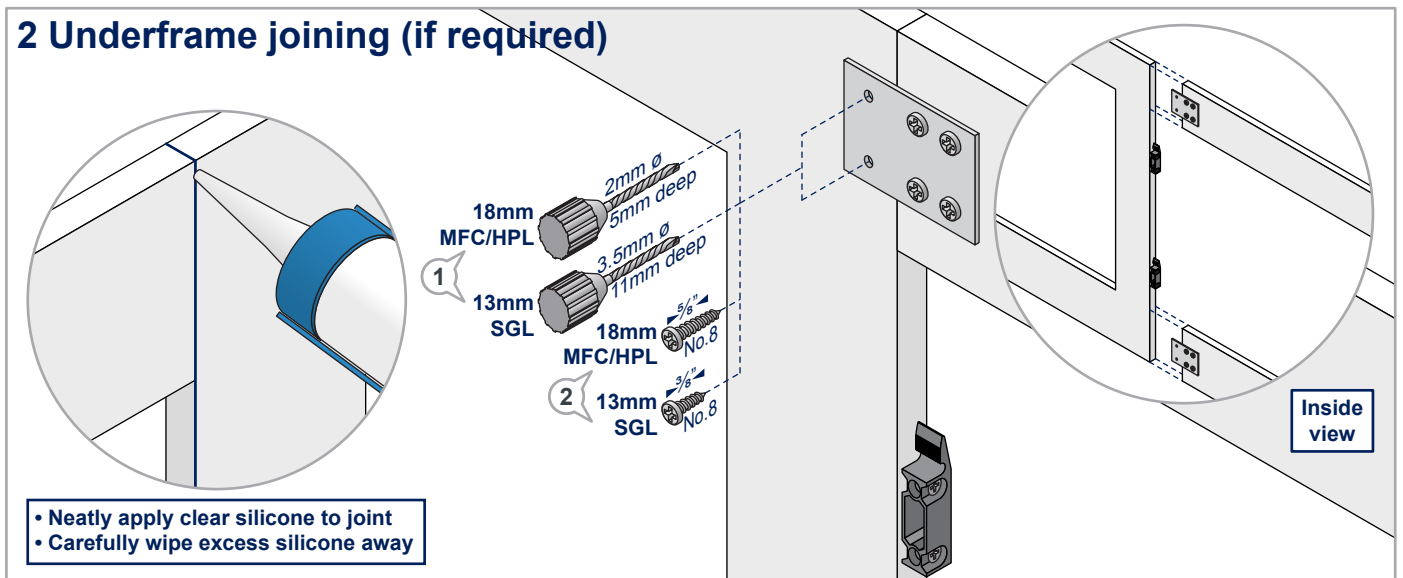
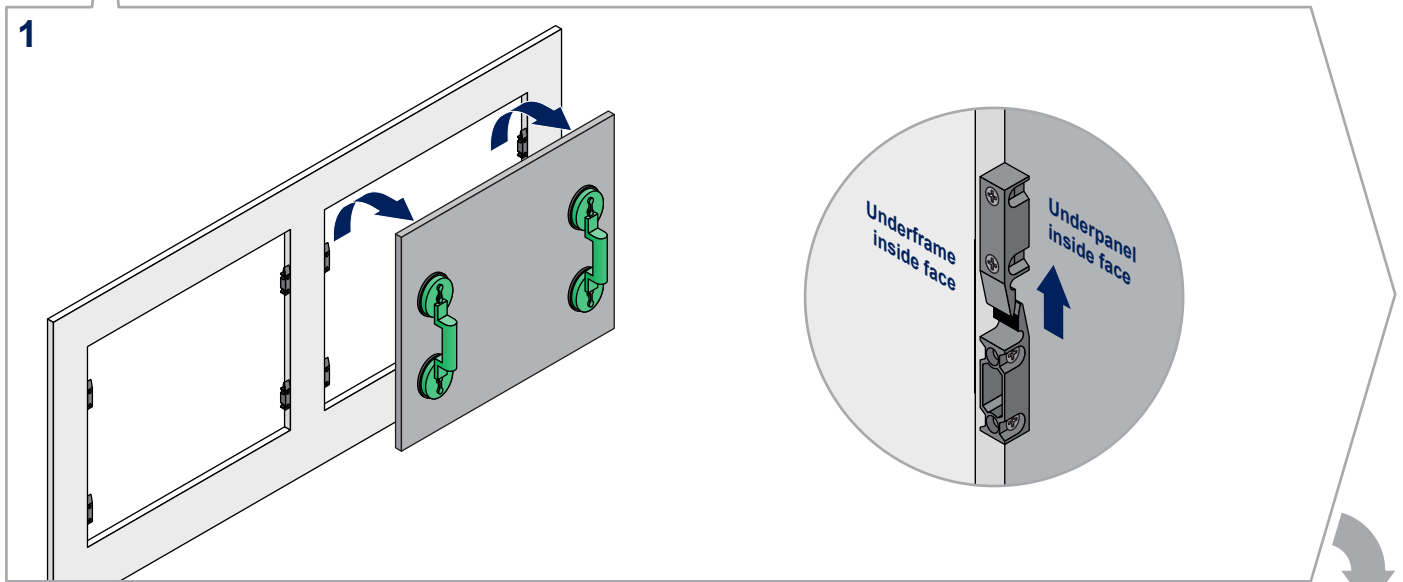
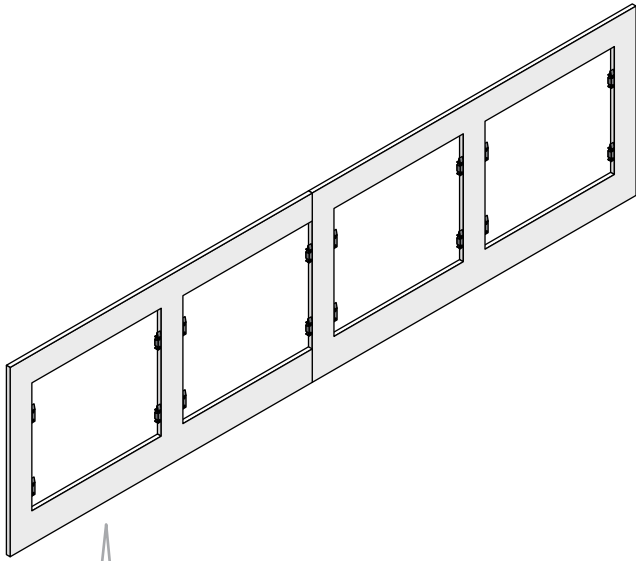

4 Underframe Fixing

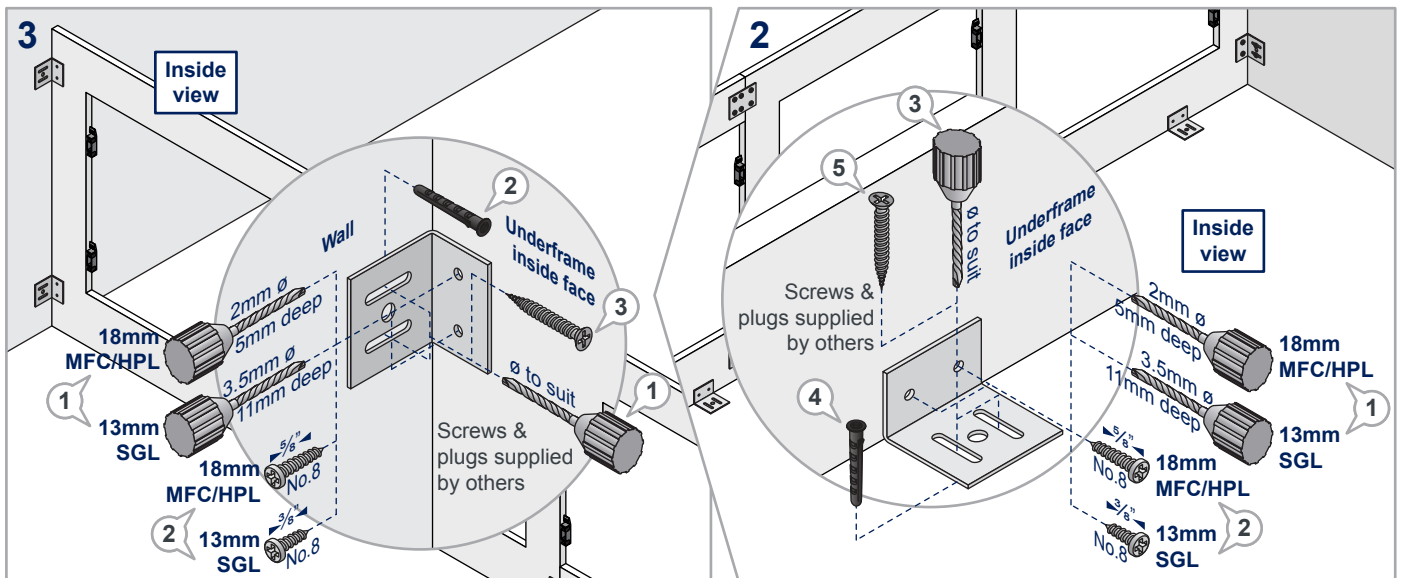
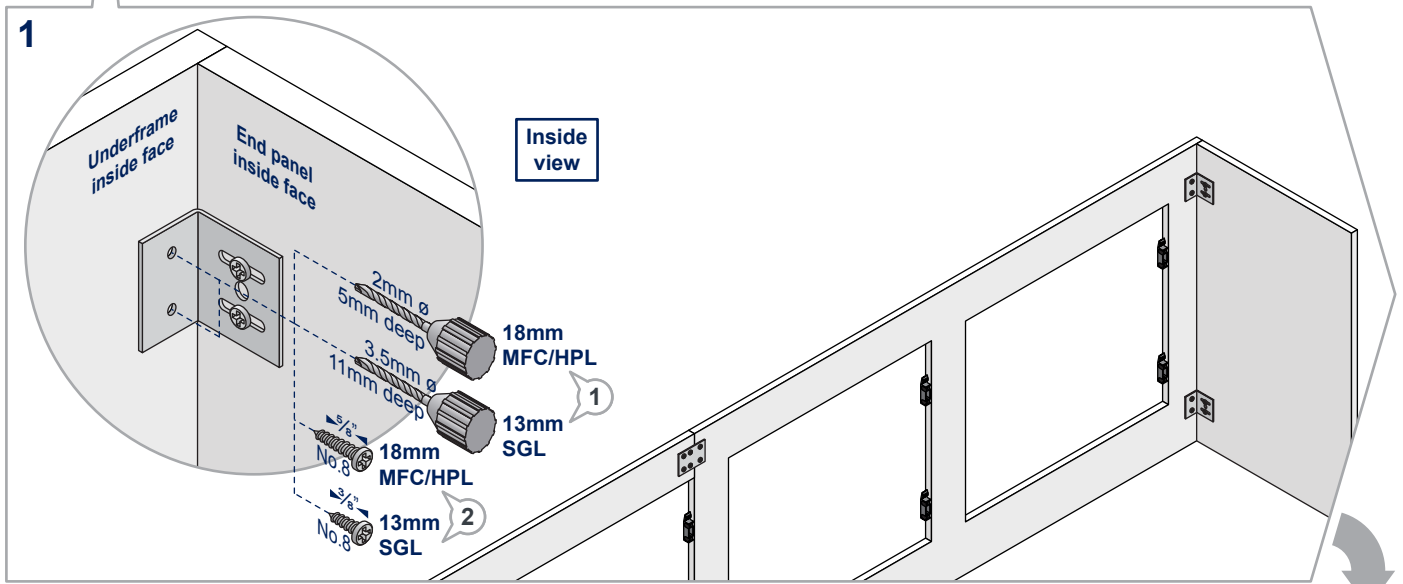
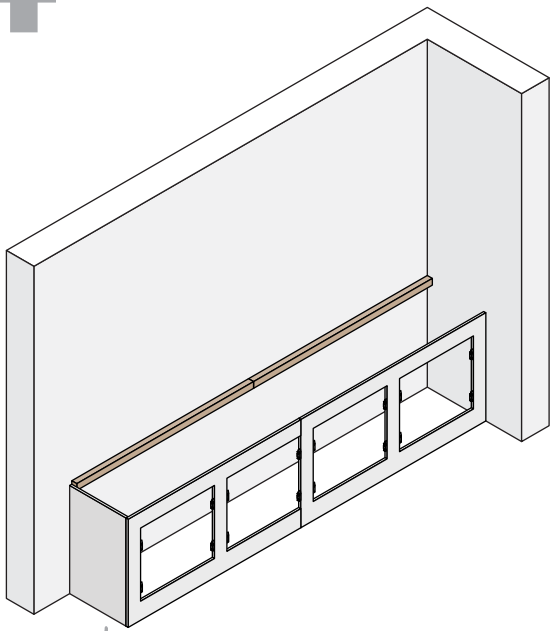

5 Vanity Top Joining (if required)

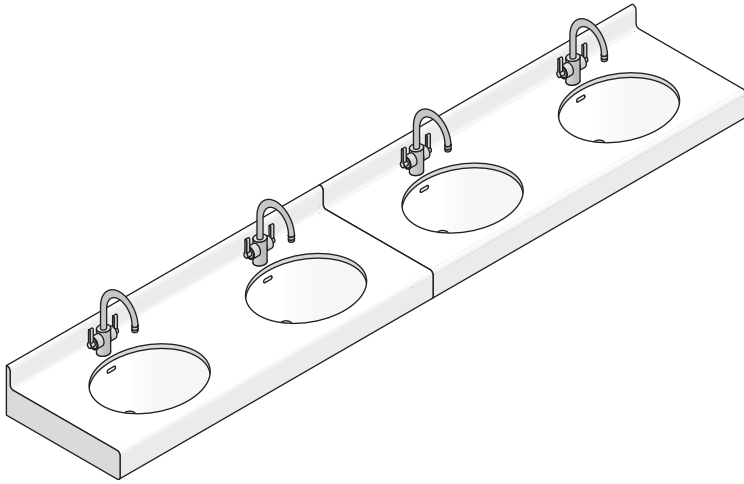

1

Prepare the joint:

- Use 100grit sandpaper on a sanding block to lightly score edges.
- Clean edges thoroughly with methylated spirit or similar.

2

Please Note:
Ensure all joint references match up

Underside view

- Bring tops together leaving a 5mm gap
- Apply adhesive in gap

4

- Carefully chisel off the adhesive bead
- Sand the joint with 320P grit (or finer) wet & dry sandpaper moving from point A to point C, gradually applying less pressure the further you get from the joint.
- Finish joint with a red Scotch-Brite pad.

3

Underside view

- Clamp tops together; the bead of adhesive should seep out of the gap
- Leave to dry until the adhesive bead has completely hardened

6 Vanity Top Preparation

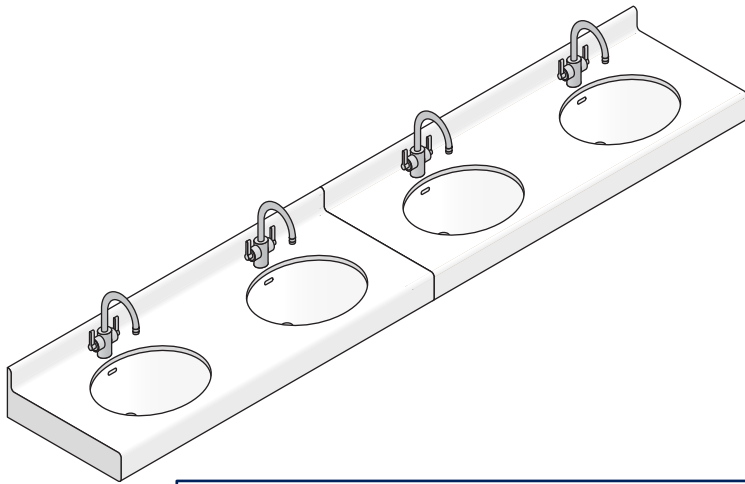

IMPORTANT NOTES BEFORE PROCEEDING:

- If vanity top is supplied with temporary divisions, please remove before proceeding
- **DO NOT** screw directly into solid surface vanity tops
- Ensure adequate support is added
- Back rail, top divisions & 12mm baton supplied by others
- Screws supplied by others

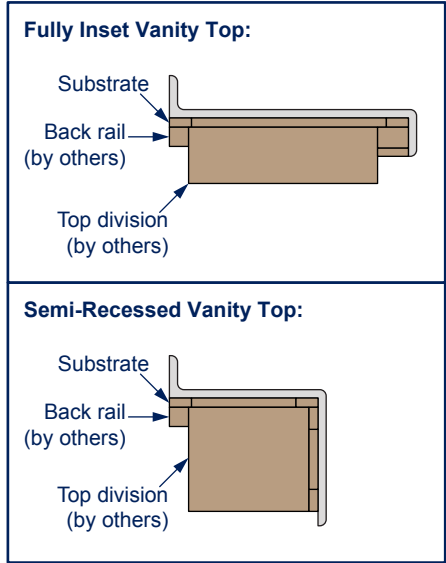

1 Fix back rail

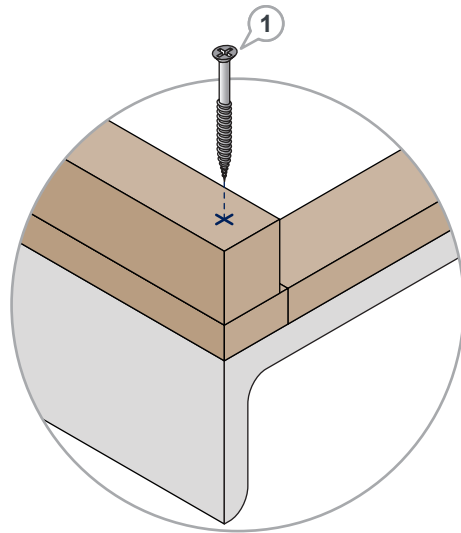
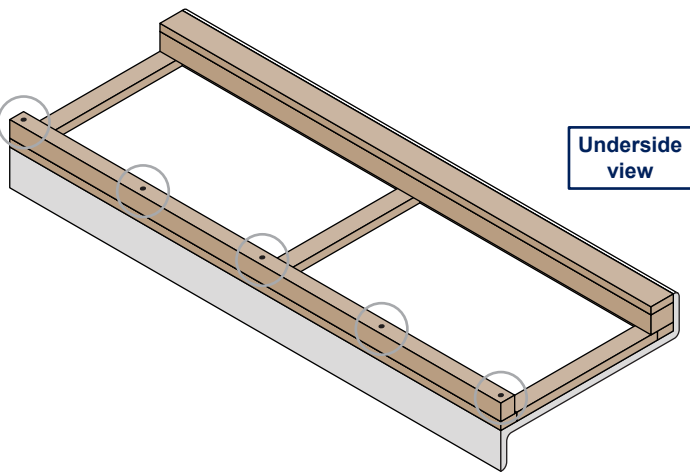

2 Fix top divisions (if required)

• Use 12mm baton add support; fix division along the width of the vanity substrate.
• Fix through back rail into division.

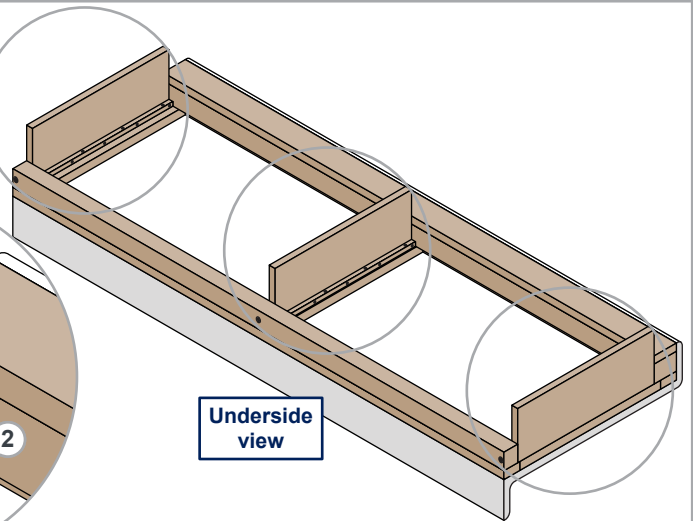
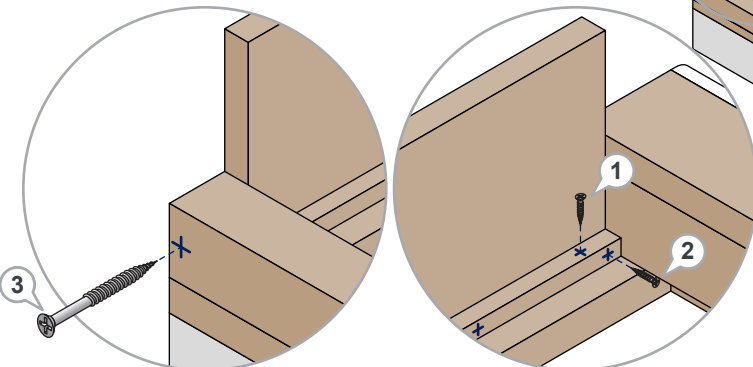

7 Vanity Top Fixing

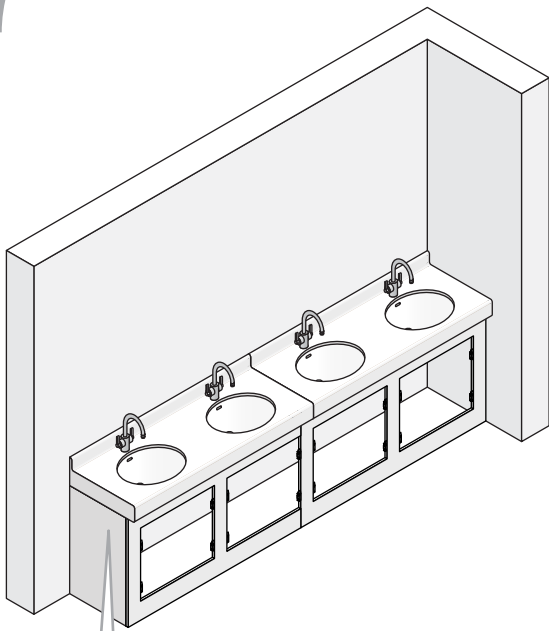

1 Fix back rail to wall

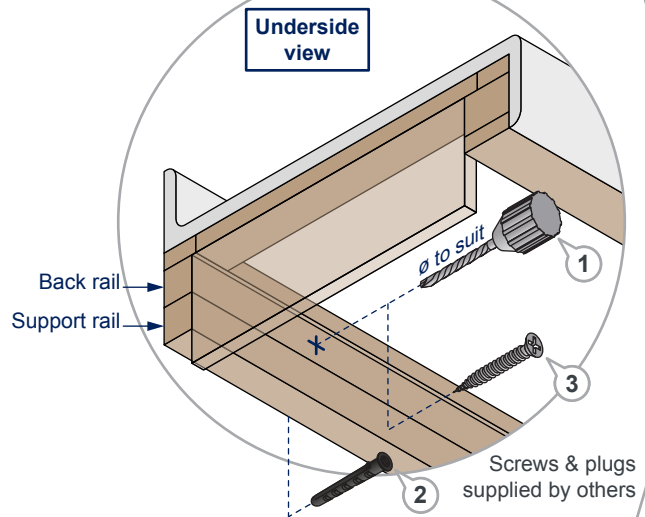
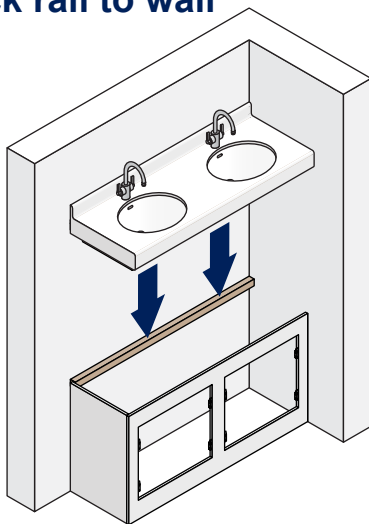

2 Fix top divisions to underframe

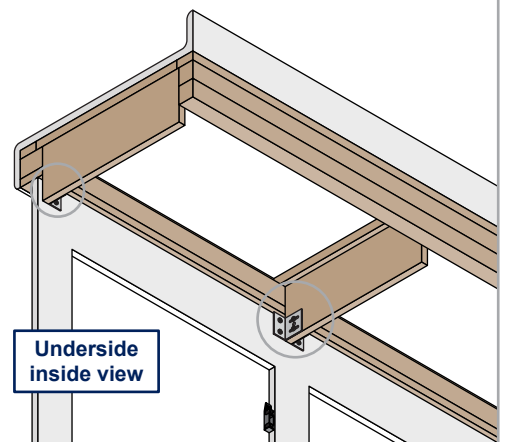
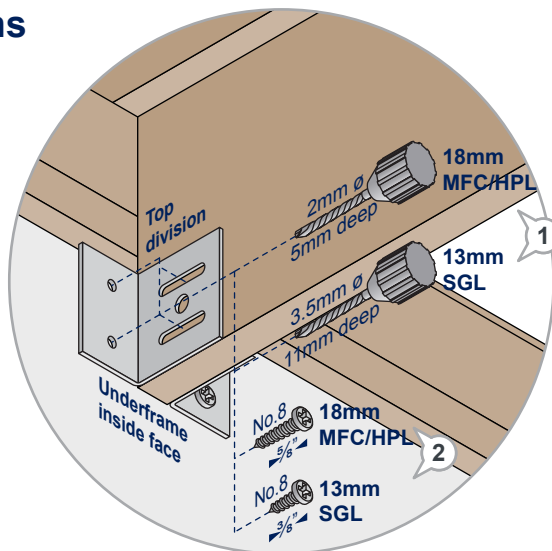

7 Finishing: Sealant

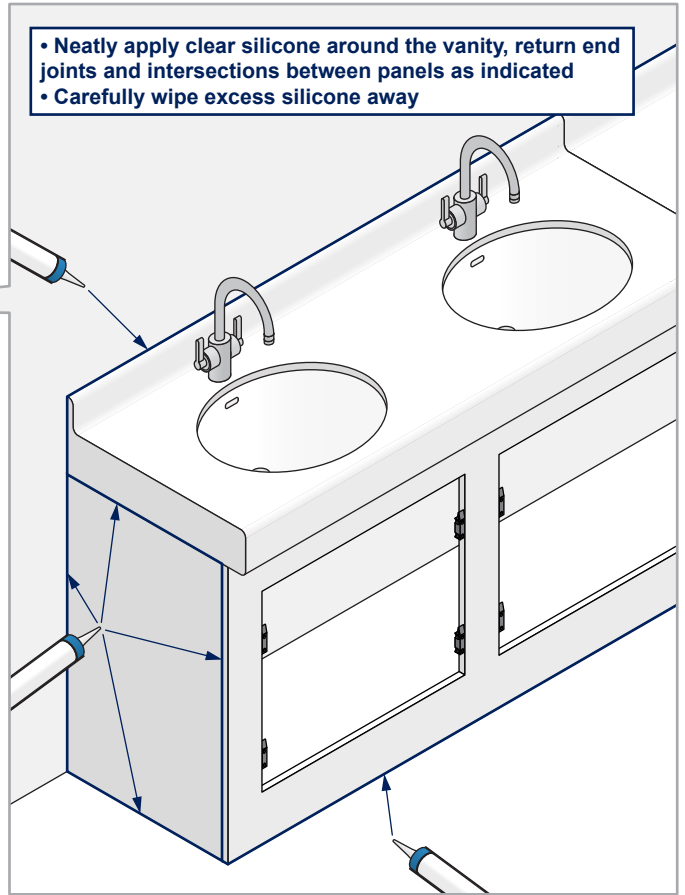
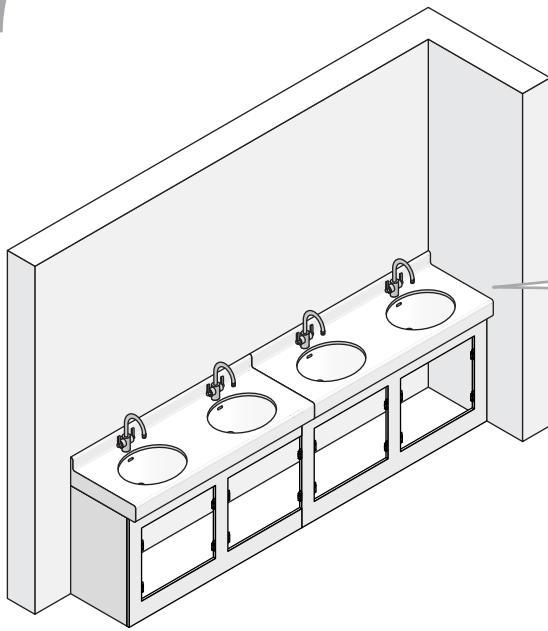

8 Finishing: Underpanels

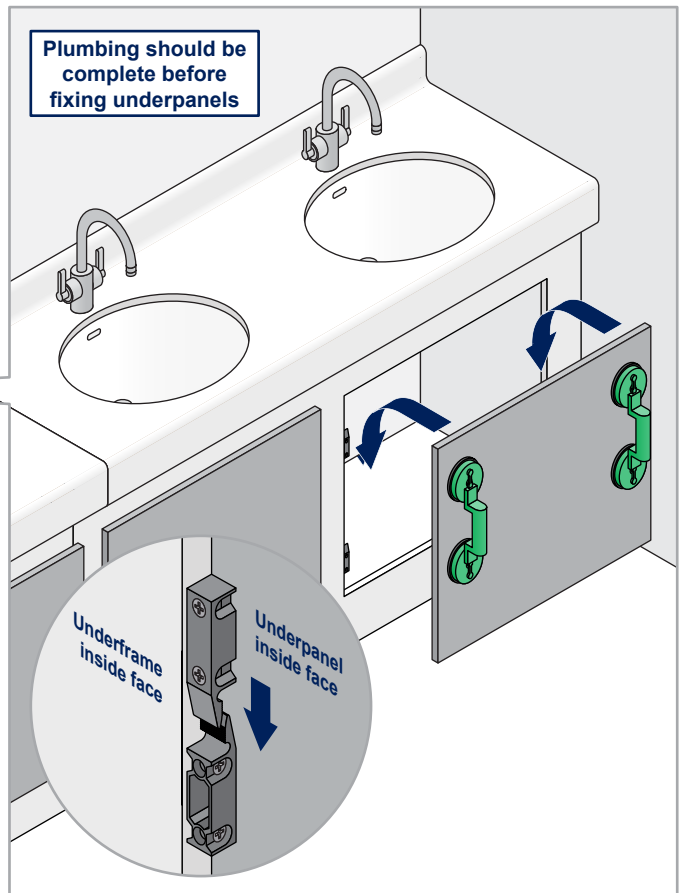
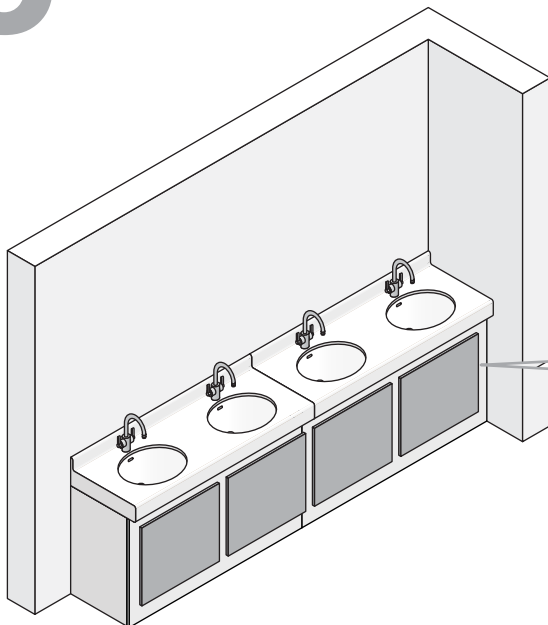

Technical Help T: 01782 277 200 | F: 01782 657 386 | e: tech@venesta.co.uk