

Site Made Vanity

We know washrooms

Installation Instructions

Recommendations for Solid Grade Laminate (SGL)

Machining

- Use tungsten carbide tipped blades/cutters or metal cutting tools.

Cutting

- For a clean cut, use carbide tipped saw blades with trapezoidal & as many teeth as possible or jigsaw with metal cutting blade.
- Alternating teeth may be suitable, but the cut will not be as clean.
- For best results, use horizontally fixed saws.

Precision Cutting

- A clean edge without flaking can be obtained.
- For best quality cut:
 1. Saw the panel slightly oversize
 2. Re-cut edge to precise measurement using a tungsten carbide tipped router cutter of required profile at 18,000 to 22,000 rpm.

Grooving

- SGL can be grooved; use a saw blade or router cutter with tungsten carbide tips.
- Groove depth must not exceed 1/3 of SGL thickness.

Drilling

- For best results use carbide bits with 3 prongs (helical bits) in preference to high-speed steel drills.
- Holes can be drilled through part or whole of thickness
- For stopped holes, minimum thickness of 1.5mm to 2mm of laminate must remain (maximum depth of hole = 11mm). Minimum of 1mm space must remain between tenon, screw tip or insert & bottom of hole (otherwise, risk of laminate cracking when fitting)

- Pilot hole diameters for screw fixing to SGL to be 0.5mm less than diameter of screw.

- Generally;
- No 6 screw - 3.5mm
 - No 8 screw - 4mm
 - No 10 screw - 4.5mm
 - No 12 screw - 5mm

- ALL pilot hole diameters should be screw tested before finalising.

Cut-Outs

- Square cut-outs:

Drill four corners (at least a 10mm diameter hole), start from one of the holes, use a jigsaw with metal cutting blade, cut the holes & square into the corners. Finish with metal file (semi-soft), ensure all sharp arrises are removed to avoid injury.

- Oval or circular cut-outs:

E.g, cutting a basin hole into a vanity top. Drill one 10mm diameter hole, start from the hole, cut according to template, use a jigsaw with metal cutting blade. Finish with metal file (semi-soft), ensure all sharp arrises are removed to avoid injury.

Resizing & re-edging previously finished panels

- We recommend the panel is cut as previously described, trim to size using a 'TREND' sunk bead router cutter running at 18,000 to 22,000 rpm, finish with 300 grit sand paper.
- Polish as described below.

Finish edges

- To eliminate machine-cutting imperfections at edges, sand with 300 grit sand paper to fine finish.
- To obtain darker edges, rub edge with cloth soaked in linseed oil or wax. Leave to dry for 30 minutes & wipe off.
- Sharp edges must be smoothed to avoid injury.

Introduction

Safety

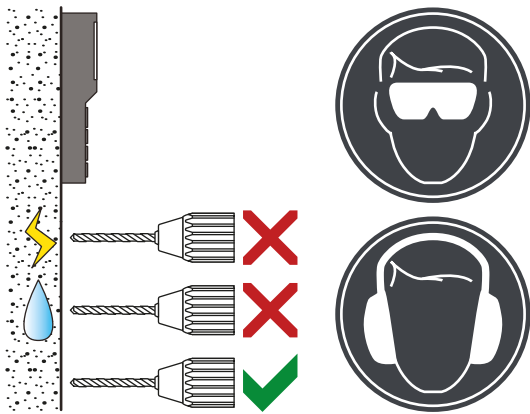

Panel Storage & Conditioning

- To ensure panels and doors remain flat ambient site conditions must be stable prior to delivery. Variable temperature and humidity can cause panels to bow and twist irreversibly.
- Before, during and after installation, temperature and humidity must be maintained between 18 - 25°C.
- Panels should not be stored outside or in areas where they may be exposed to water or humidity.
- Wet trades and forced-drying procedures should be complete and the building fully dried out.
- Use supports and spacers to elevate panels off the floor and keep space between panels; air must be able to circulate around each panel evenly.
- The ideal base is a slatted pallet with base board; however, if these are not available, panels should be carefully stacked on bearers suitably spaced to maintain flatness. Spacing of bearers should not exceed 400mm.
- Avoid storage conditions where extremes of temperature and humidity can occur.
- Panels must be allowed to equalise to levels approximating to those that will prevail during building use.
- BS EN438 recommendations should be adhered to:

Temperature – 18 to 25°C

Air humidity – 40 to 60%

BS 4965 Flatness: Flatness to BS 4965 can only be guaranteed at the time of delivery.

Toolbox

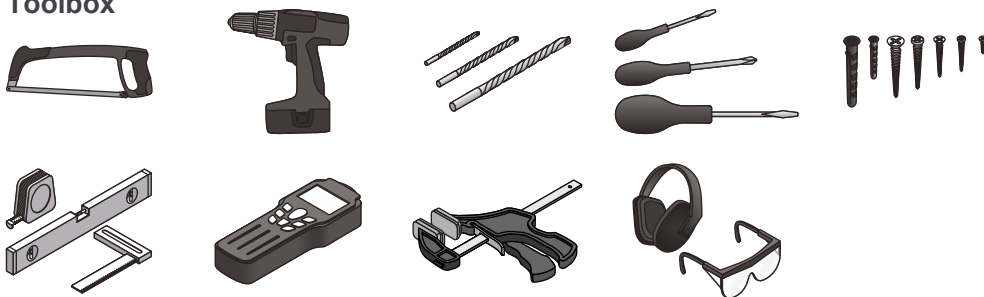

Prerequisites

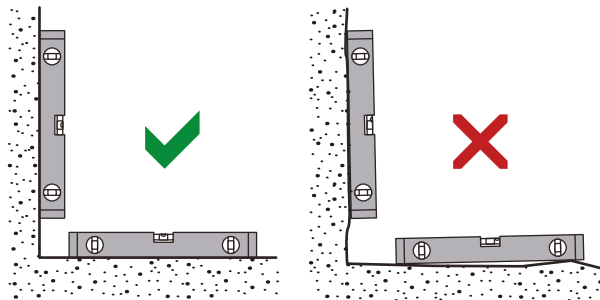

Secure Fixing

It is vital that the structural integrity of walls, ceilings and floors is capable of taking the dynamic and static loads imposed by the fixings to support the product. Insufficient structural integrity will invalidate guarantees and cause product instability.

The surfaces being fixed into should be firm and stable, without deflection and have good fixing retention properties over the length and width of the bearing surface.

Particular care should be taken with studwork walls and suspended ceilings which will usually require the inclusion of a pattress to sufficiently strengthen the structure.

Poor security of fixings will compromise performance and could lead to failure of the product.

Screws and Fixings supplied to fix components to the floor or wall structural material should be tested to ensure they are suited and have sufficient holding power to accept the static and dynamic loads required to support our products. Due to the multitude of floor and wall constructions, it should not be assumed that the fixings supplied are suitable for all installations. If you are uncertain contact your local specialist fastening supplier.

Do NOT overtighten fasteners, if using power drivers make sure that the torque settings are correct.

Cleaning & Maintenance

Please consult our cleaning & maintenance guide.

1 Layout & Levelling



- These cubicles require very careful setting out and are manufactured to tight tolerances.
- Installers should be highly experienced and be qualified to a carpentry joiner level.
- Before installation, if in any doubt about how to install these products please contact our technical department.
- **PPE:** Wear personal protection equipment at all times.
- **Unit Dimensions:** Refer to layout drawings +/- 5mm.
Any tolerances can be made up with the flashgaps.
- It is the installer's responsibility to ensure that framing is adequately fixed.

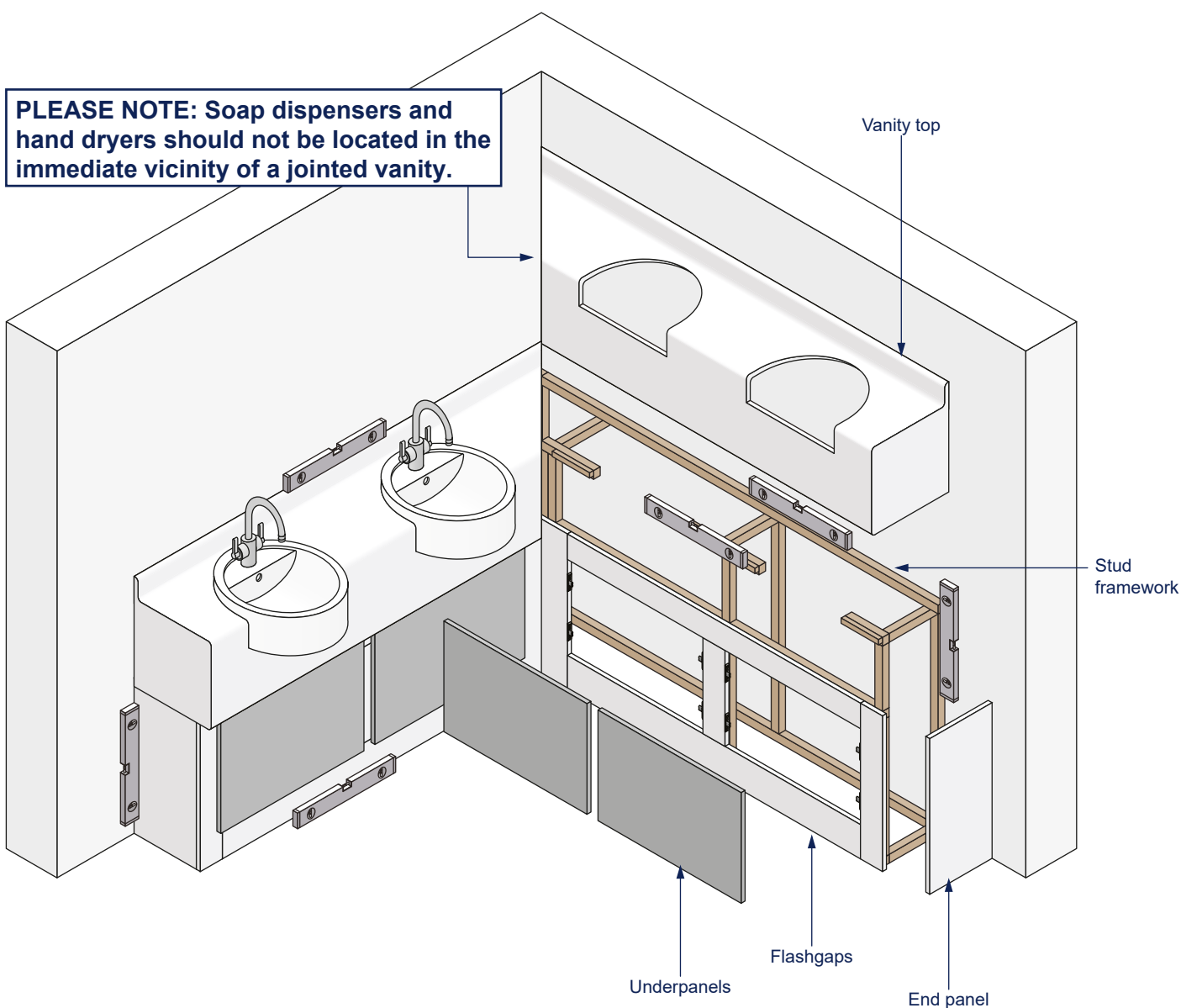

PLEASE NOTE: when applying adhesive or silicone, ensure any surplus that bleeds out to the seen surfaces is immediately removed with an appropriate cleaner so that no residue is left.

2 Stud Framework

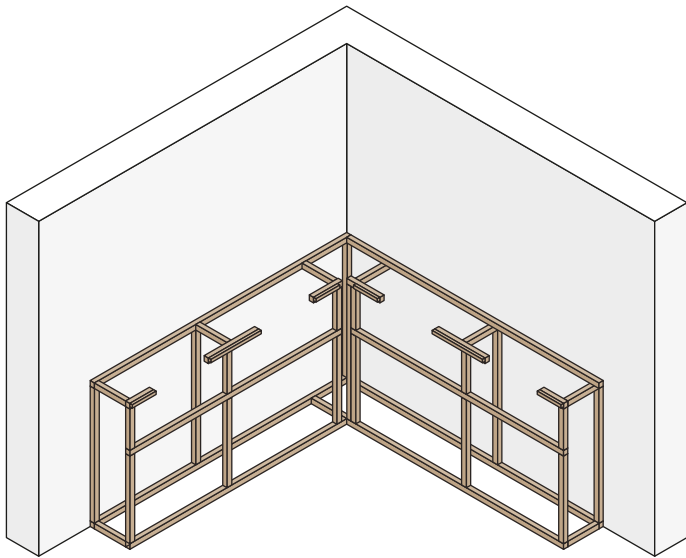

Refer to layout drawing and guide below for framework construction:

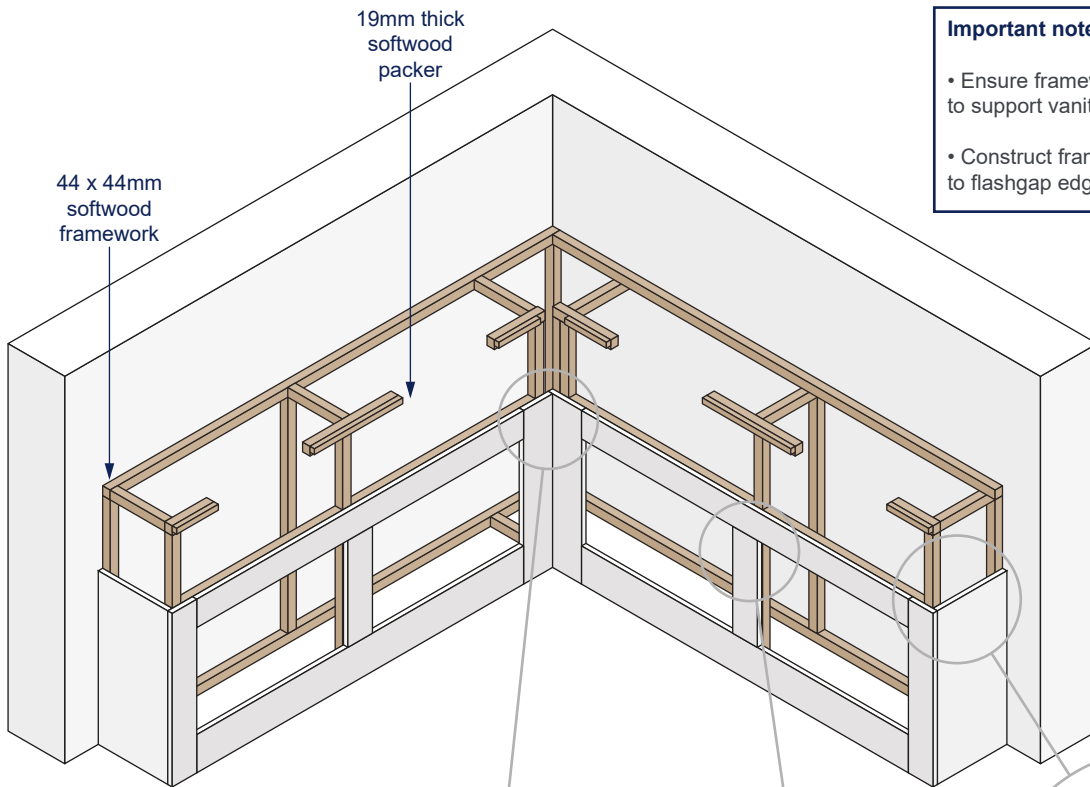

Important notes:

- Ensure framework is strong enough to support vanity unit and sanitaryware
- Construct framework to be as close to flashgap edge as possible

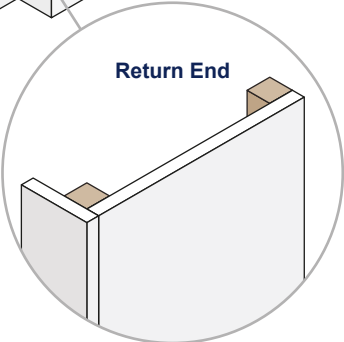
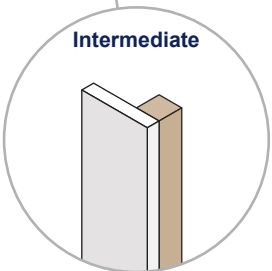
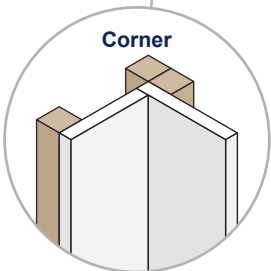

Please note: framework is not supplied

3 Flashgap Fixing

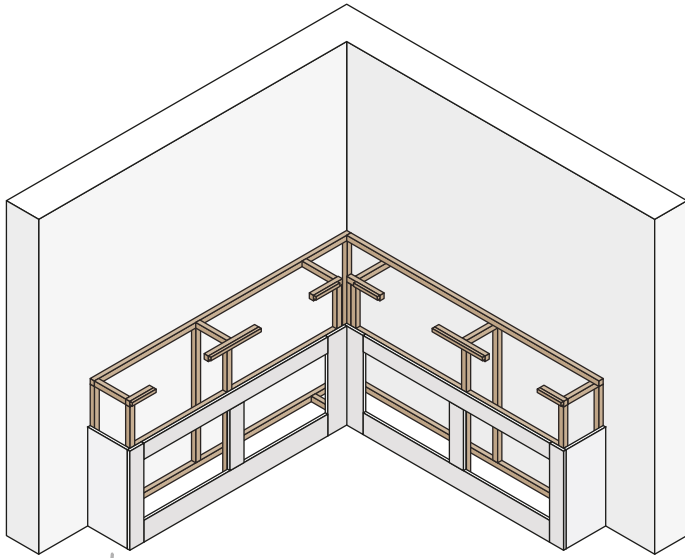

Refer to layout drawing and guide below to fix flashgaps:

Important notes:

- Flashgaps are supplied as standard sizes to be cut on site by others
- Fix flashgaps to stud framework
- Use countersunk screws
- Screws must be located in position so they will be hidden when panels are fitted
- Once fixed, seal flashgaps with silicone

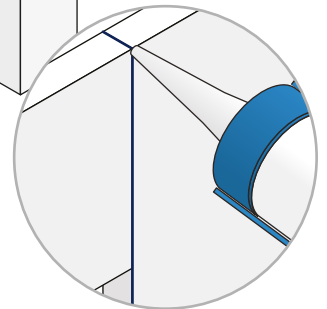
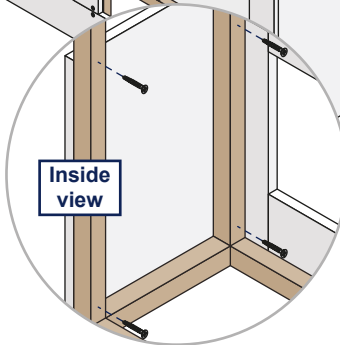
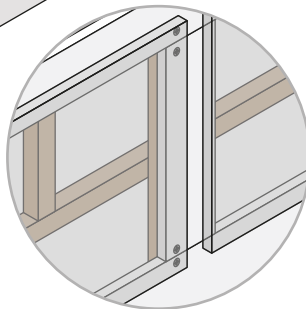
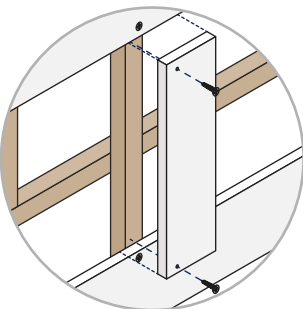
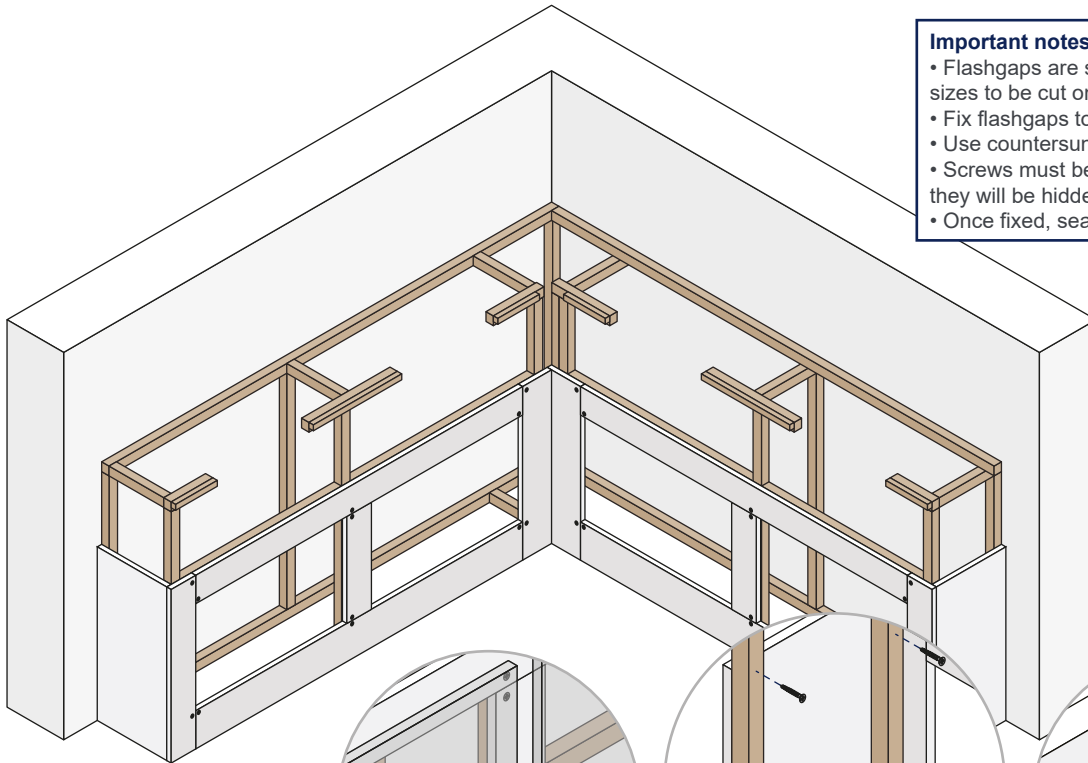

Screws must be in position to be hidden when panels are fitted

Return end:
• Glue or screw from inside
• DO NOT break through outside face

Neatly apply clear silicone to all joints
• Carefully wipe excess silicone away

4 HPL Vanity Top Jointing & Cutting (if required)

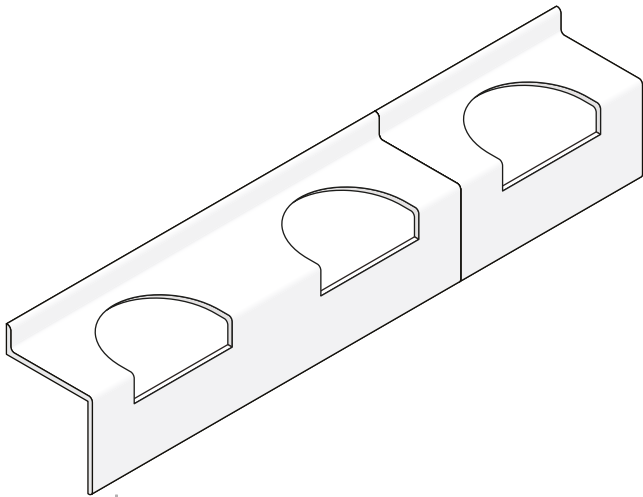

1 **Cut vanity top to suit basins:**

- Use template supplied with basin
- DO NOT fix basins at this stage

2 **Neatly apply masking tape to joint edges**

3 **Apply clear silicone to joint**

Please Note:
Ensure all joint references match up

Underside view

Apply appropriate adhesive

5

- Carefully wipe excess silicone away
- Remove masking tape

4

Underside view

Bring vanity tops together with draw bolts provided

- Remove excess adhesive

5 SGL Vanity Top Jointing & Cutting (if required)

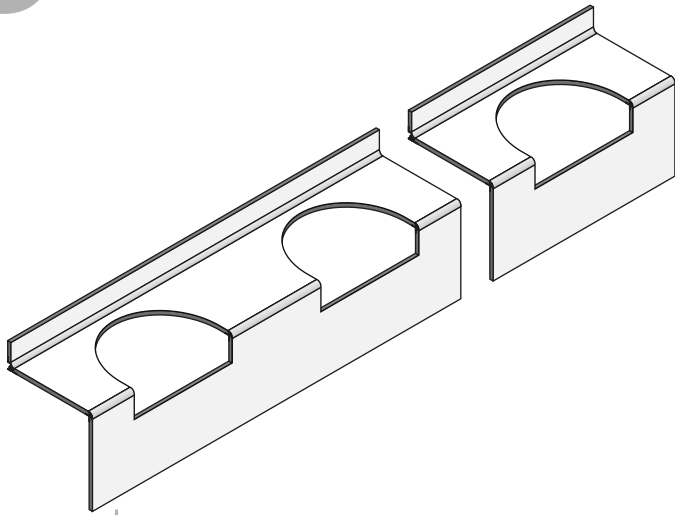

1 **Cut vanity top to suit basins:**

- Use template supplied with basin
- Refer to page 2 for SGL cutting recommendations
- DO NOT fix basins at this stage

2 **Neatly apply masking tape to joint edges**

3

Please Note:
Ensure all joint references match up

Underside view

Apply appropriate sealant

5

- Carefully wipe excess silicone away
- Remove masking tape

4

- Bring vanity tops together by fixing through aluminium plate from underneath
- We recommend using No.8 x 1/2" screws
- Refer to page 2 for SGL pilot hole drilling recommendations
- Remove excess glue/sealant

6 Vanity Top Fixing

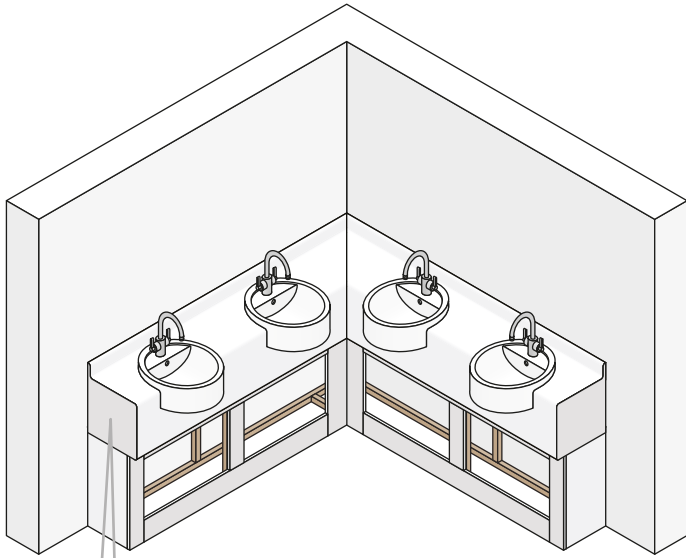

Refer to guide below to fix vanity tops:

- Fix and secure vanity top to stud framework
- Fix and seal basins to vanity top

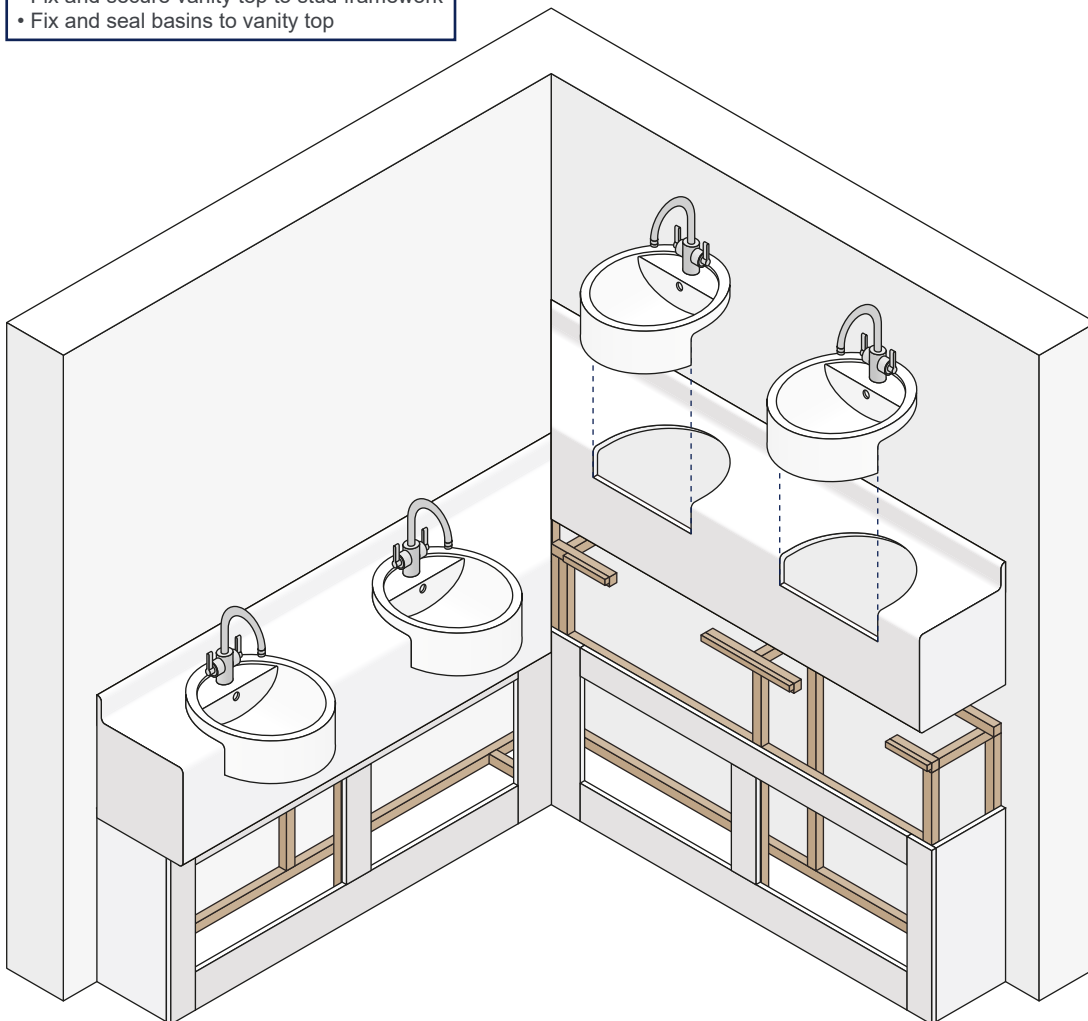

7 Underpanel Clip Fixing

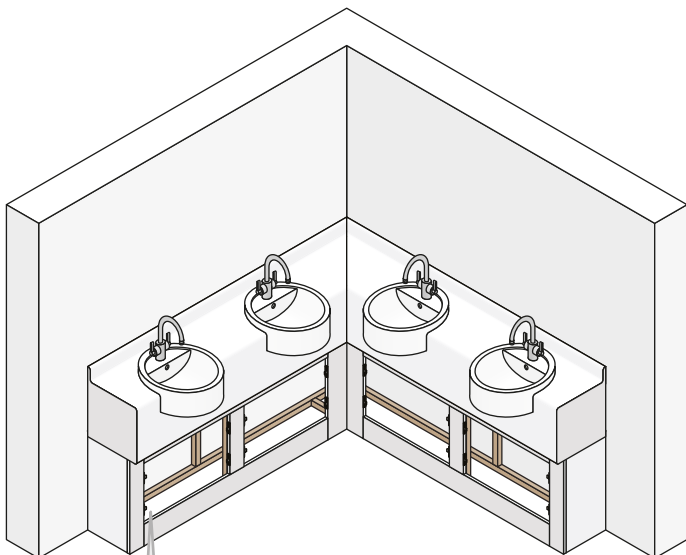

Please note:
Plumbing should be complete before fixing panels

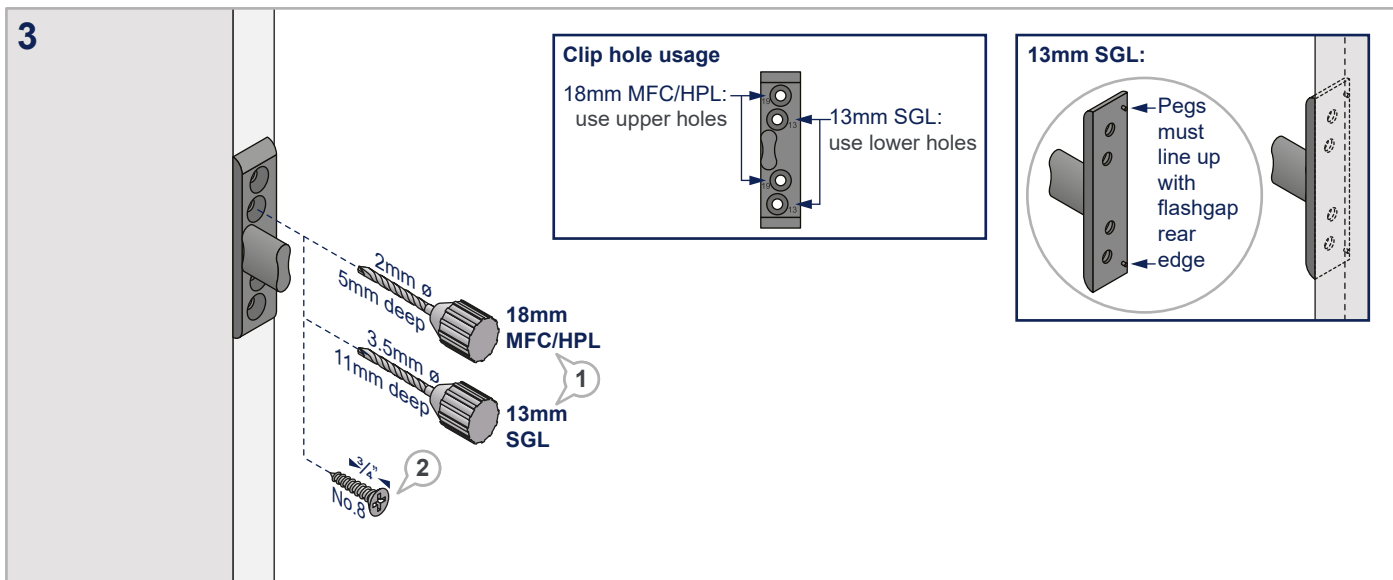
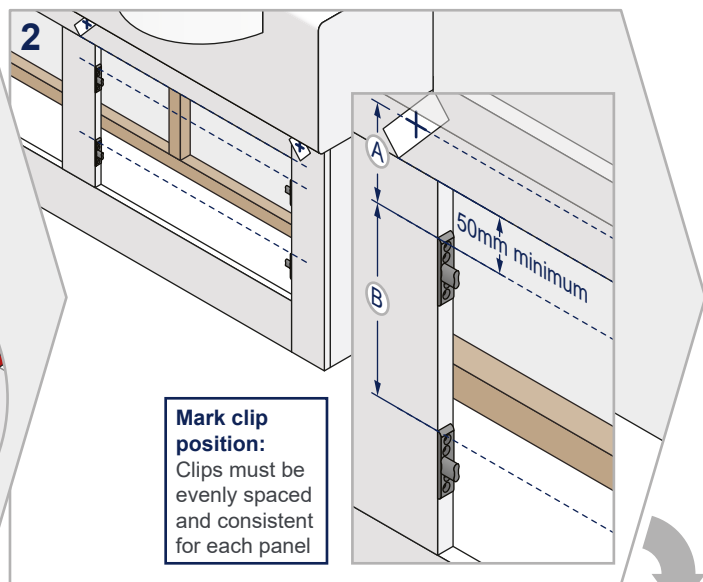
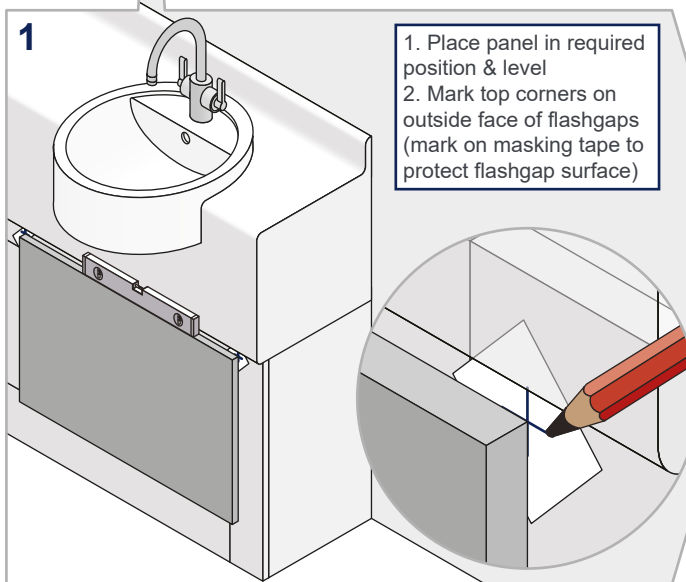

e: tech@venesta.co.uk

T: 01782 277 200 | F: 01782 657 386

Technical Help

7 Underpanel Clip Fixing (Continued)

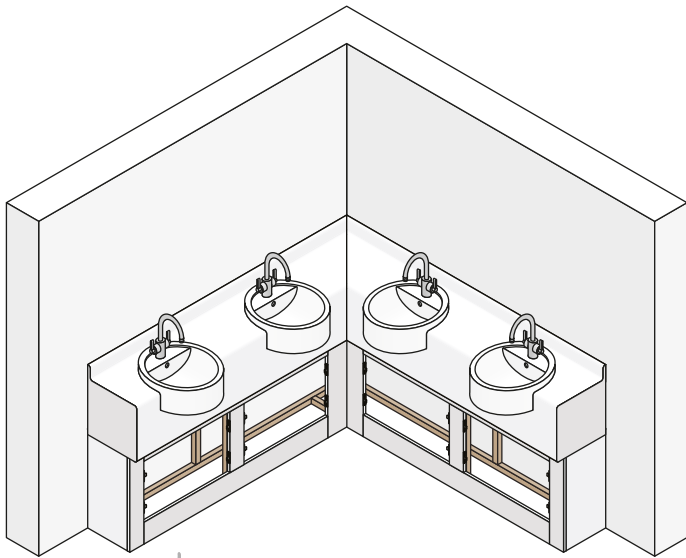

4 **Mark clip position:**
Distances A & B to be the same as those marked on flashgaps (step 2, previous page)

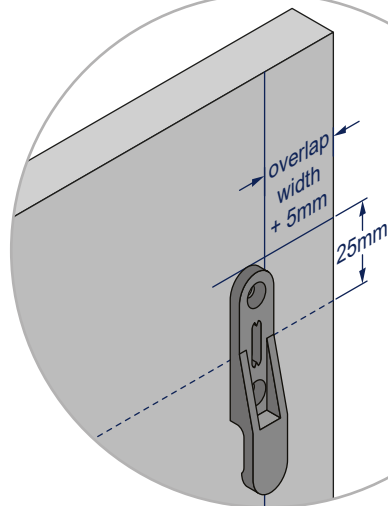
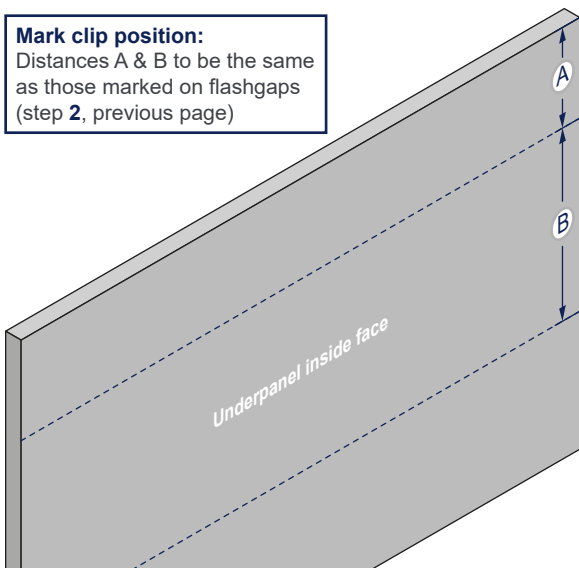

5

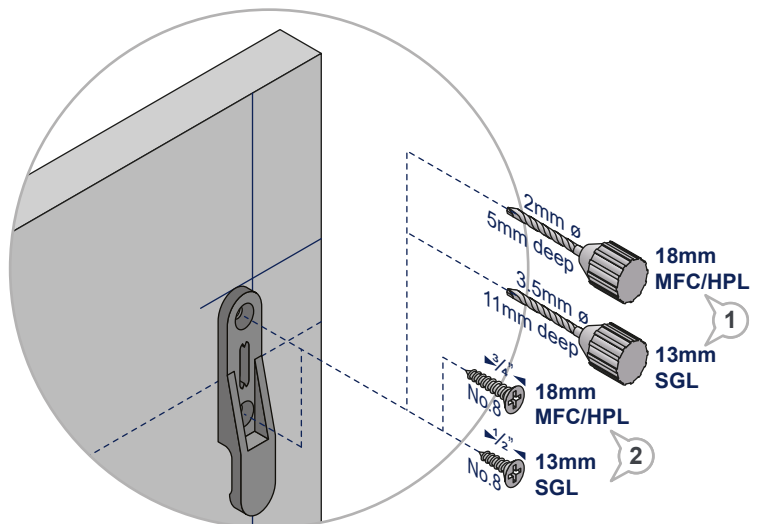
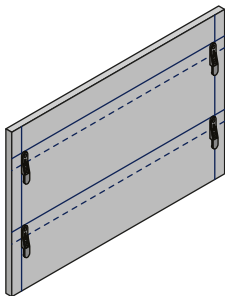

8 Finishing: Sealant

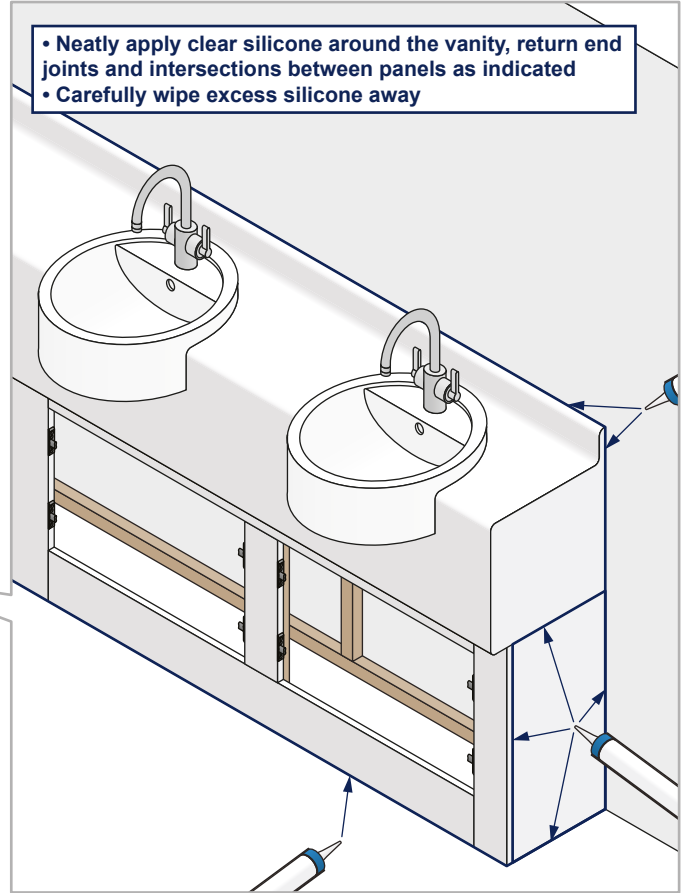
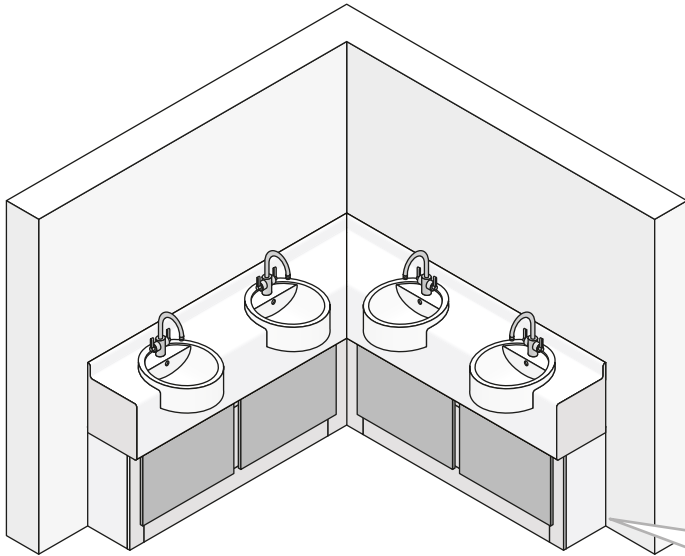

9 Finishing: Underpanels

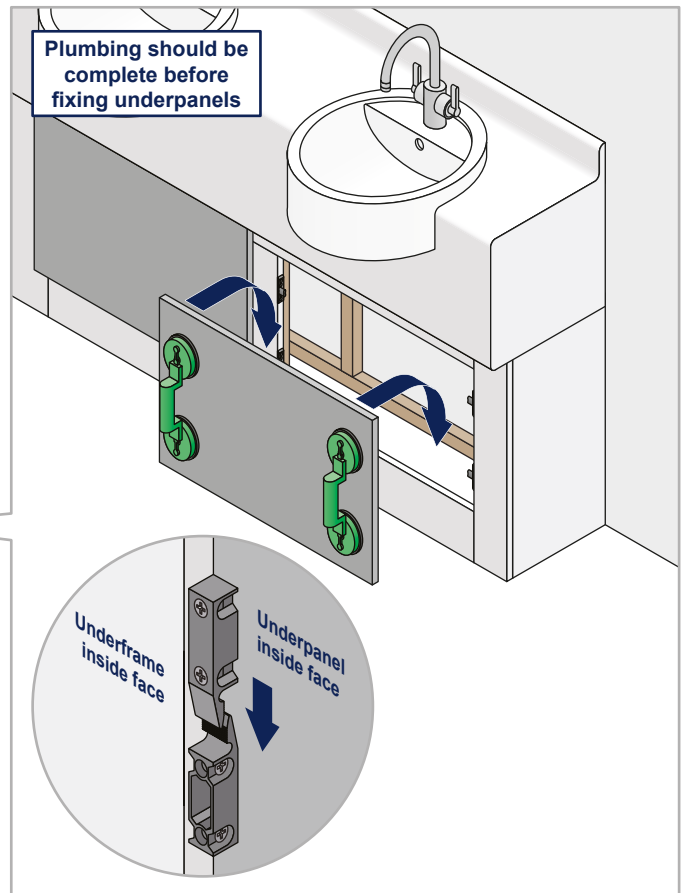
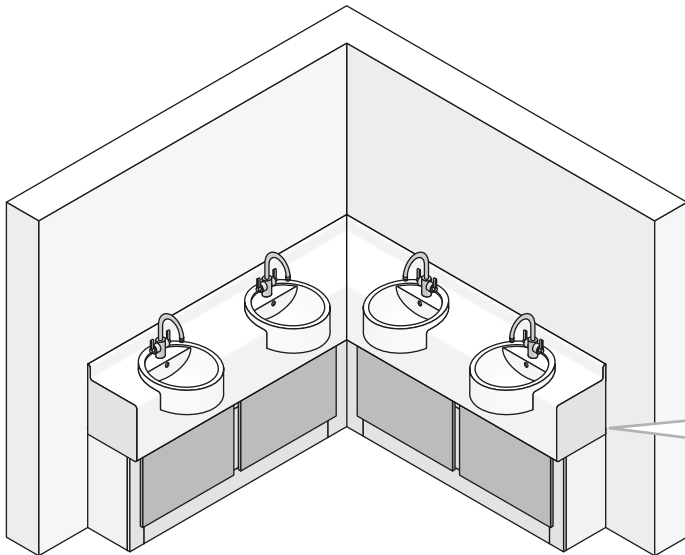

Technical Help T: 01782 277 200 | F: 01782 657 386 | e: tech@venesta.co.uk