

# Sub-construction for Wall-mounted Longlight

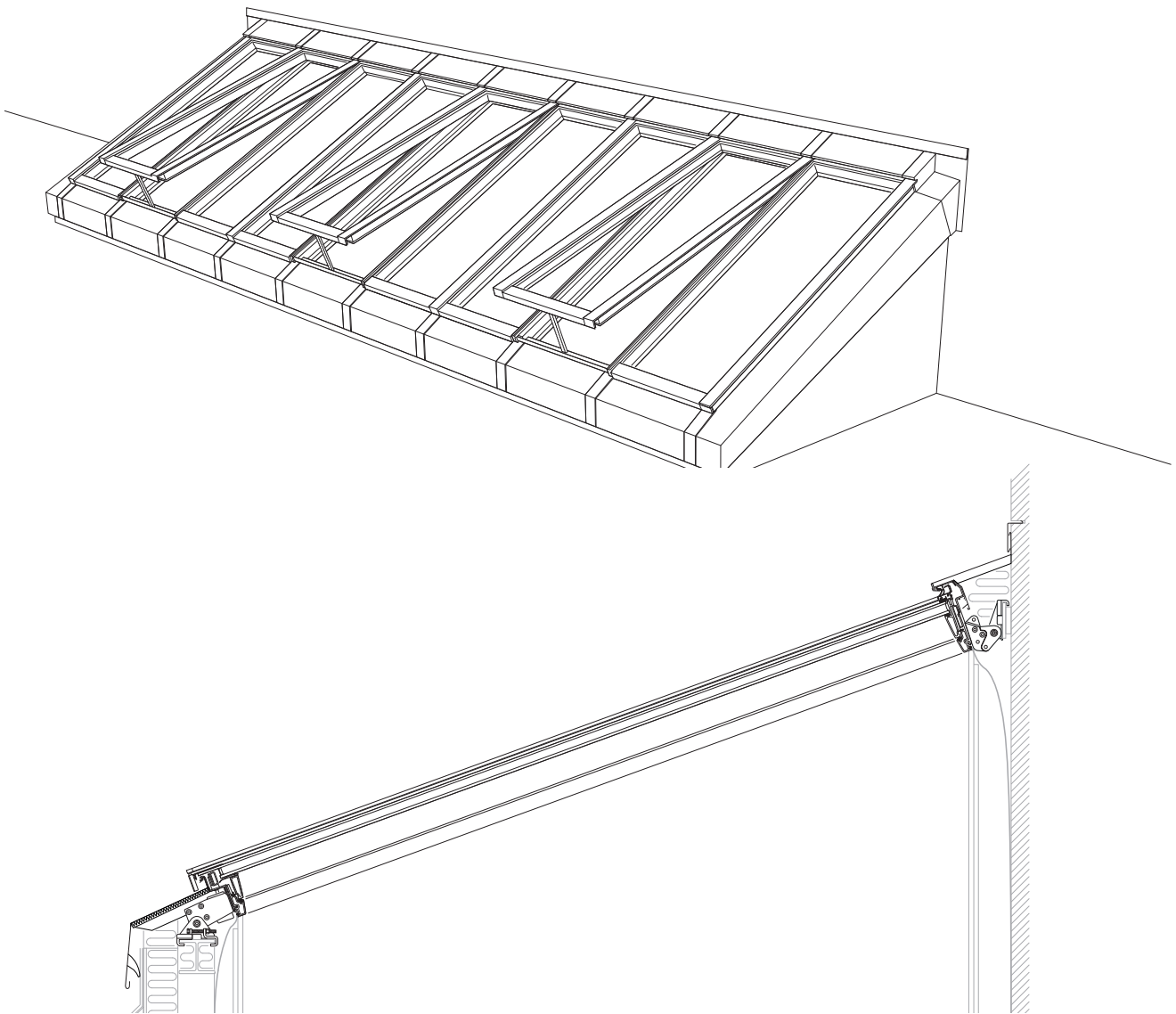

## Subconstruction for Wall-mounted Longlight at 5-40° pitch

VELUX modular skylights in a wall-mounted longlight solution, can be installed on a sub-construction made of steel, wood or concrete finished with a steel profile at the top of the bottom section and a steel flat bar mounted on the wall. The sub-construction raises the modules above the roof surface, protecting the construction against water and drifting snow, and provides the supporting base for the modular skylights.

The sub-construction is not included in the VELUX delivery. The sub-construction as shown in the drawing only represents general principles and must be designed and dimensioned to fit the specific building project, local architectural style and practice, and the directions of other building suppliers.

## Axonometric

---

- A: Opening width
- B: Opening length
- C: Sub-construction width
- D: Sub-construction length
- O: Height of gable
- P: Height of wall steel profile
- R: Placement of groove

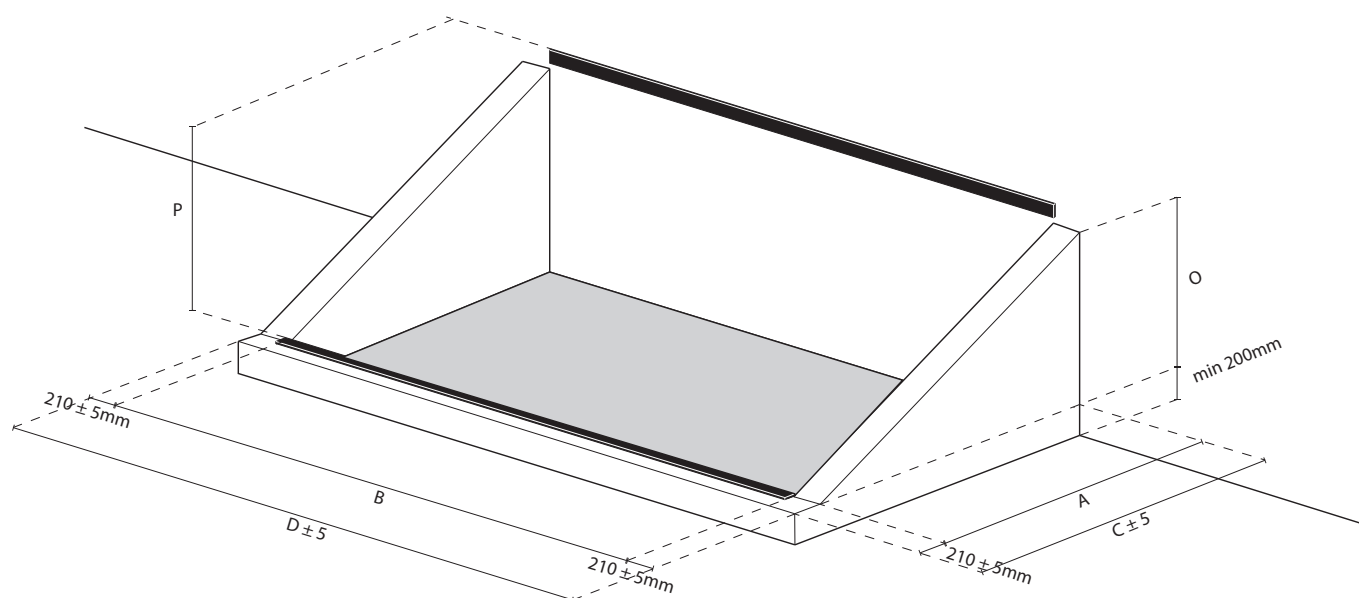

## Building site measurements

### Elevation

- A: Opening width
- B: Opening length
- C: Sub-construction width
- D: Sub-construction length
- O: Height of gable
- P: Height of wall steel profile
- R: Placement of groove
- X: Distance between steel profiles

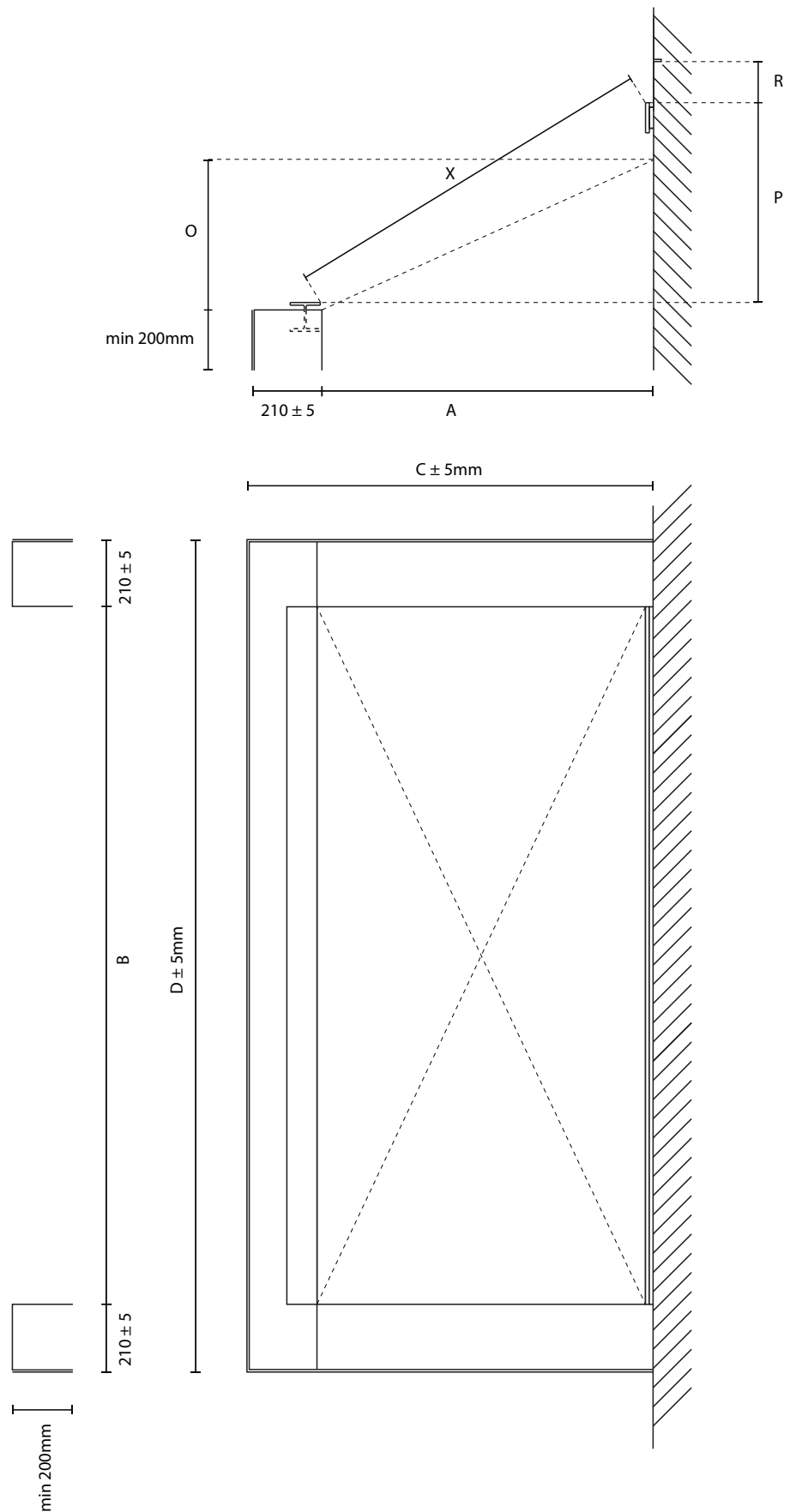

## Connecting to the wall

The surface of the wall must be suited for fixing screws, and either cutting a groove in or applying mastic sealant to and must be prepared for such accordingly.

When cutting a groove for the top head flashing, the groove must subsequently be sealed again.

If the wall is not suited for cutting a groove, the top head flashing is left out, and the main head flashing is sealed to the wall.

The choice of sealant to use in the groove or on the flashing must be according to national requirements, local practice, and the directions of other building suppliers.

The sealant is not part of the VELUX delivery.

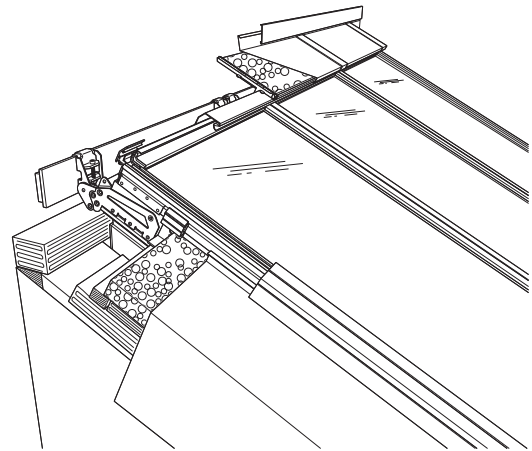

## Connecting to the roof

The surface on which roofing felt is laid must be prepared according to applicable standards for roofing materials and best building practice.

The roofing felt must be applied to the outside of the sub-construction before mounting the skylight modules.

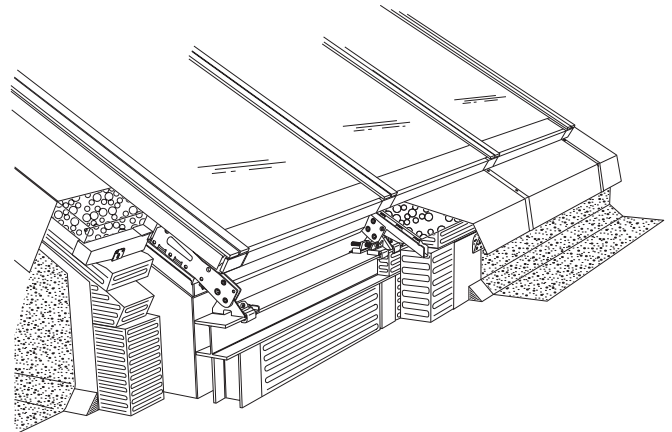

## Sub-construction dimensioning requirements

The roof construction is subject to deflection after installation of the skylight modules. These deflections include subsequent roof covering, various building installations and external loads such as snow and wind etc. The sub-construction must be designed to withstand all these loads and the deflections must be limited to maximum  $1/400 \times$  the full length of the sub-construction.

After completing the sub-construction, it must be secured against water penetrating the roof construction and insulation.

For load capacity and weight of the skylight modules, please contact your local modular skylight supplier.

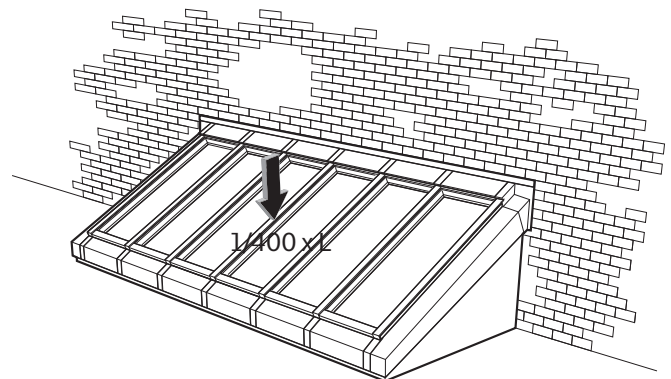

## Sub-construction variants

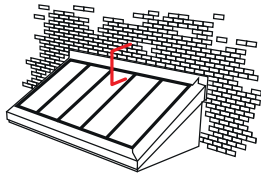

### Cross section top

Options of sub-constructions for wall-mounted longlight solutions. Please note that the top groove in the wall can be left out. The head flashing is then sealed to the wall, using a suitable mastic sealant or equivalent.

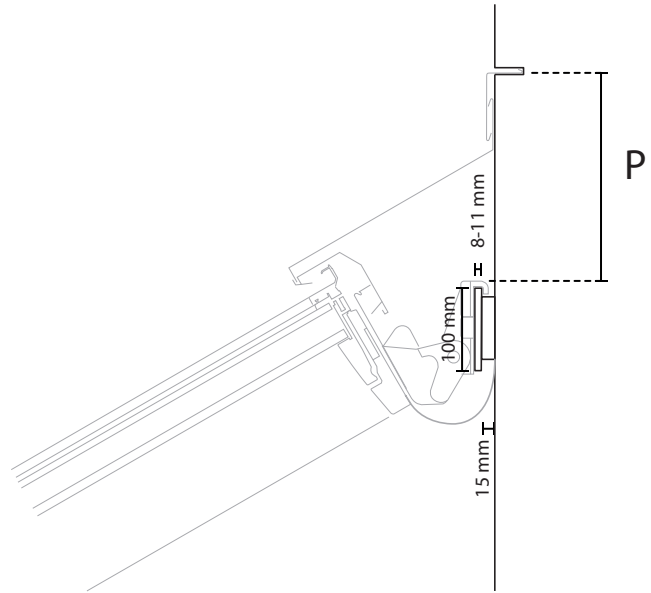

## Securing modular skylights to the wall

### Steel flat bar

Wall-mounted modular skylights must be mounted on a steel flat bar on the wall. The steel flat bar must be 100 mm wide and 8-11 mm thick. There must be at least 15 mm free space underneath the steel, both vertically and horizontally to allow room for the clamps.

**The number and size of fixings for securing the steel profile to the building must be dimensioned by others to fit each project.**

Requirements to the steel flat bar:

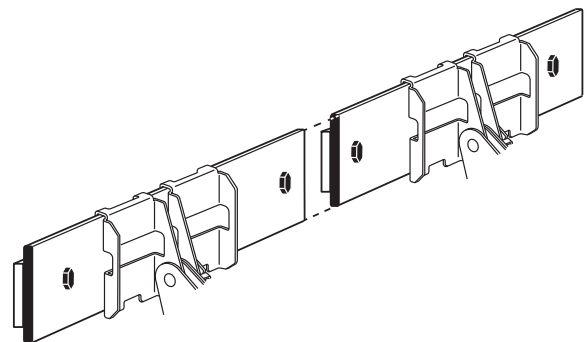
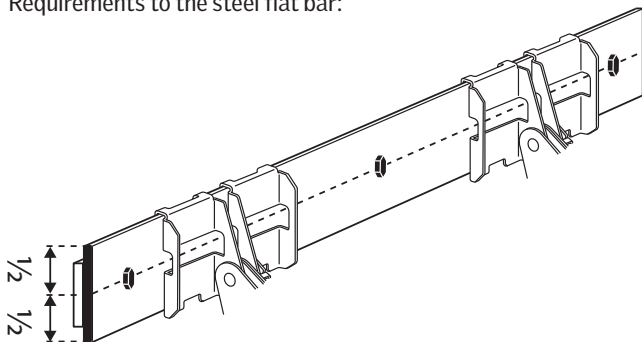

- The blocking-up of the steel must be in the full length of the steel flat bar
- The steel can be secured using screws or bolts along the middle of the profile

- Connection of steel profiles must not collide with clamps

## Sub-construction variants

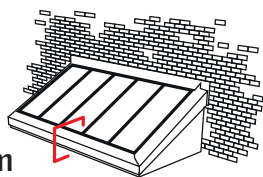

### Cross section bottom

Options of sub-constructions for wall-mounted longlight solutions. Please note that the width stated indicates the distance from the finished exterior of the roofing material to the interior of the wood/steel profile.

Wood with flat steel

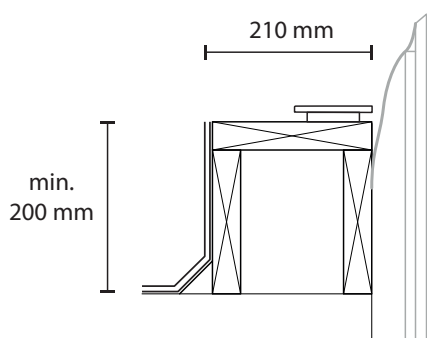

Wood with wooden batten

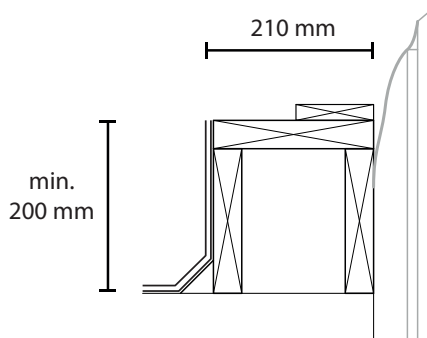

Steel with steel profile

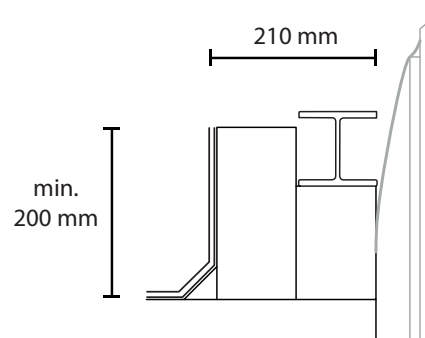

Concrete with steel profile

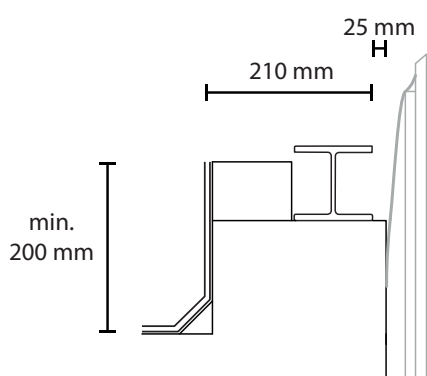

Concrete with flat steel

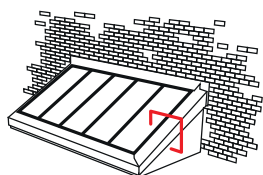
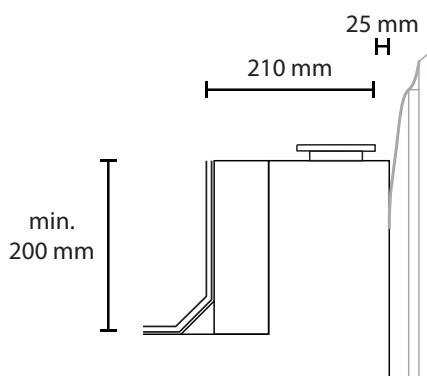

### Longitudinal section

In the gable construction for wall-mounted longlight at 5-40° pitch, the height of the sub-construction must be at least 200 mm at the front of the skylight modules.

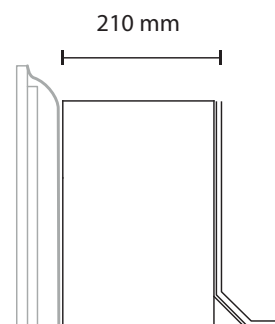

## Securing modular skylights to the sub-construction

### Using steel profile

The sub-construction can be finished at the top with steel profile or steel flat bar, which provides a level and stable surface for the skylight modules and forms a base for fitting installation brackets with clamps.

**The number and size of fixings for securing the steel profile to the sub-construction must be dimensioned by others to fit each project.**

The following standard steel profiles are suited for installation of VELUX modular skylights in longlight solutions:

EU steel beams:	British steel beams:
INP 220	UB 178 x 102 x 19
IPE 200	UB 203 x 102 x 23
HE100A	UB 254 x 102 x 22
HE100B	UB 254 x 102 x 25
	UB 305 x 102 x 25
	UB 305 x 102 x 28
	UB 305 x 102 x 33

In case a stronger construction is needed, the steel profile can be replaced with a stronger profile. In this case, a different size installation bolt must be ordered separately from VELUX Company Ltd. The following profiles can be used:

EU steel beams:	British steel beams:
INP 240, 260, 280	UB 305 x 127 x 37
IPE 220, 240	UB 305 x 127 x 42
HE120A	UB 356 x 127 x 33
HE120B	

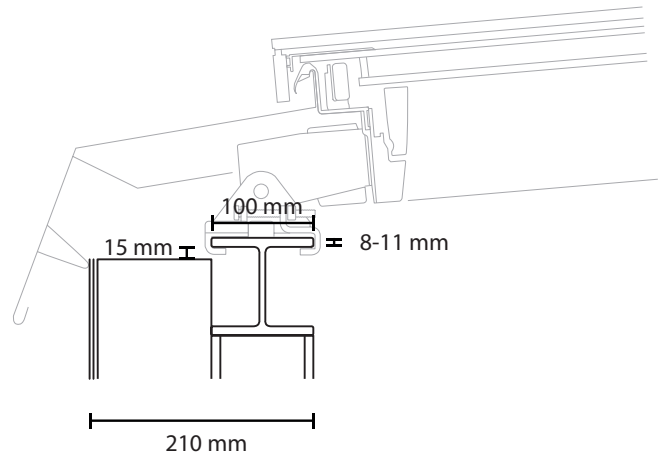

Wood or steel sub-construction with steel profile

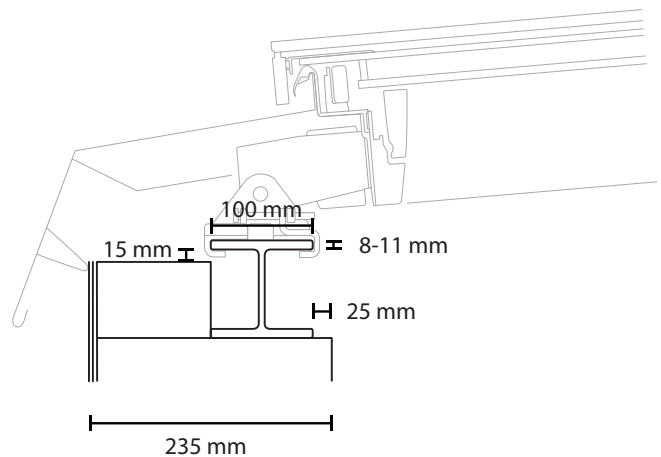

Concrete sub-construction with steel profile

### Straightness of steel profile

Requirements to the straightness of the steel profile is maximum 2 mm over any given 2 meters.

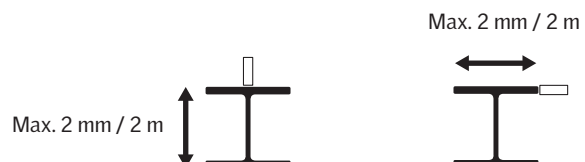
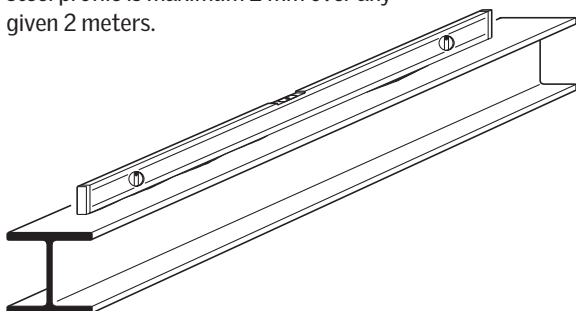

## Using steel flat bar

When mounting the modular skylights on steel flat bar, the steel must be 100 mm wide and 8-11 mm thick. In addition there must be at least 15 mm free space underneath the steel both vertically and horizontally to allow room for the clamps.

Requirements to a steel flat bar:

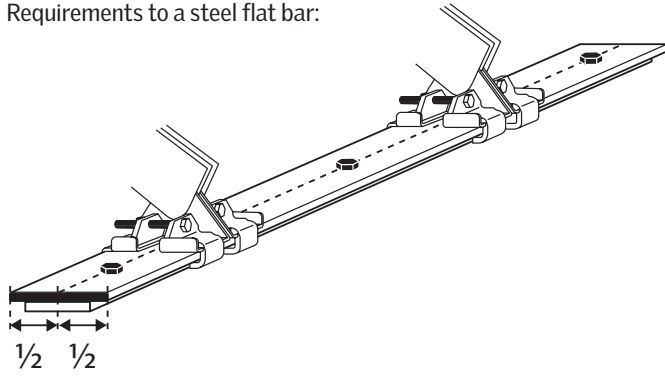

- The blocking-up of the steel must be in the full length of the steel flat bar
- The steel can be secured using screws or bolts along the middle of the profile

**The number and size of fixings for securing the steel profile to the sub-construction must be dimensioned by others to fit each project.**

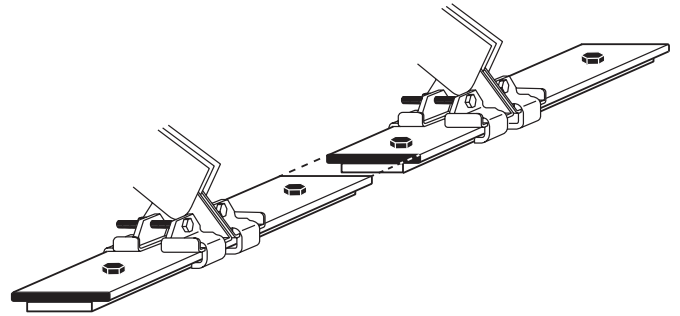

- Connection of steel profiles must not collide with clamps

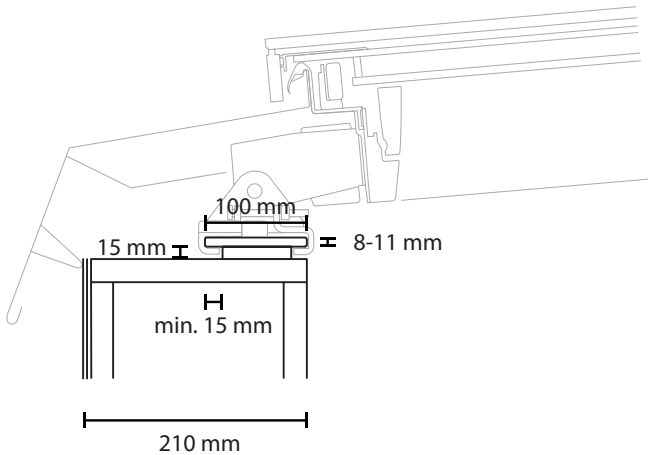

Steel or wood sub-construction with steel flat bar

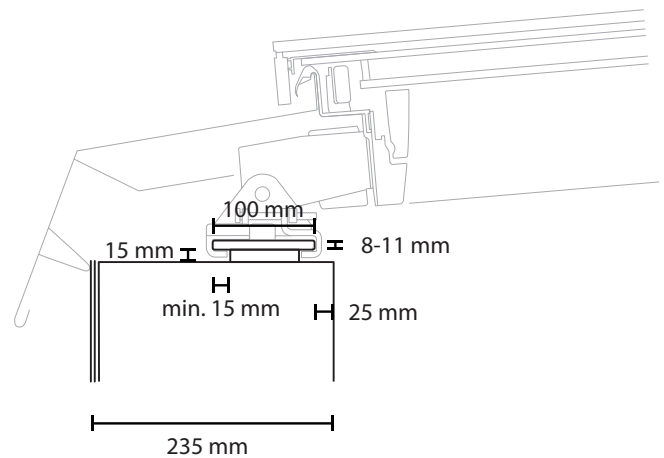

Concrete sub-construction with steel flat bar

## Straightness of a steel flat bar

Requirements to the straightness of the steel profile is maximum 2 mm over any given 2 meters.

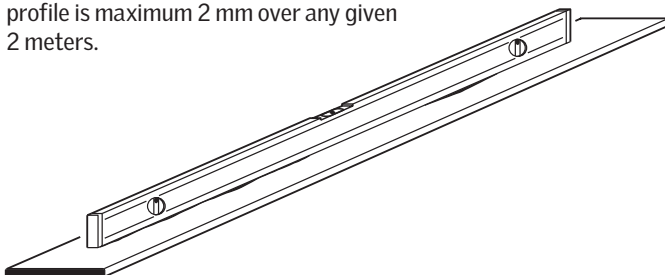

## Using wooden battens

The sub-construction for the longlight can also be finished off using a wooden batten on which the bottom shoes of the modular skylight can be secured directly, without using the supplied installation clamps.

The skylight modules are mounted on the batten using screws through the bottom shoes. These screws are not included in the VELUX delivery, and the correct dimensions must be ensured by the customer. There are 4 holes in each shoe, 2 x  $\varnothing 5$  and 2 x  $\varnothing 8.5$ .

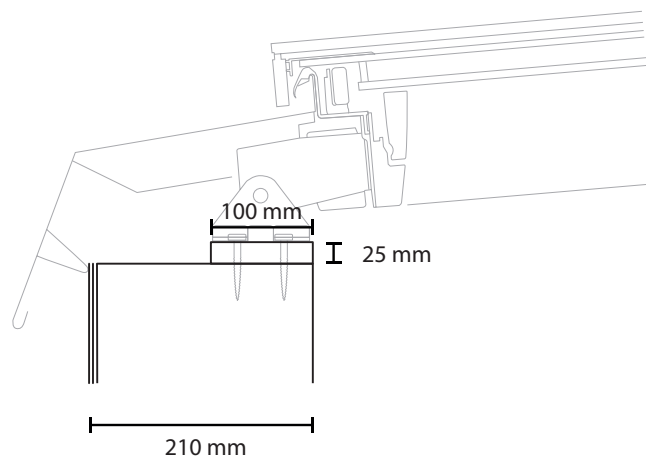

Wood sub-construction with wooden batten