

Uponor



Uponor Smatrix Wave

EN INSTALLATION AND OPERATION
MANUAL

Table of contents

1	Copyright and disclaimer	4
2	Preface	5
2.1	Safety instructions	5
2.2	Limitations for radio transmission	5
2.3	Correct disposal of this product (Waste Electrical and Electronic Equipment)	5
3	Uponor Smatrix Wave	6
3.1	System overview	6
3.2	Example of a system	7
3.3	Uponor Smatrix Wave components	8
3.4	Accessories	17
3.5	Functions	18
4	Install Uponor Smatrix Wave	21
4.1	Installation procedure	21
4.2	Prepare for installation	21
4.3	Installation example	22
5	Install Uponor Smatrix Wave controller	25
5.1	Placement of controller	25
5.2	Install controller antenna	26
5.3	Attach controller to the wall	27
5.4	Connect the slave module (optional)	27
5.5	Connect components to controller	28
5.6	Connect the controller to AC power	43
5.7	Test actuators	43
5.8	Register relay module M-161	44
6	Install Uponor Smatrix Wave thermostats and sensors	45
6.1	Placement of thermostats	45
6.2	Label thermostats	45
6.3	Insert batteries	45
6.4	Connect external sensor to thermostat (optional) ..	46
6.5	Sensor input function	47
6.6	Attach a thermostat to the wall	48
6.7	Attach to table stand (T-163, T-165, T-166, and T-168 only)	50
6.8	First startup of digital thermostats	50
6.9	First setup of digital thermostats	52
6.10	Register thermostats in controller	53
6.11	Register system devices	54
7	Install Uponor Smatrix Wave thermostatic head	56
7.1	Placement of thermostatic head	56
7.2	Label thermostatic heads	56
7.3	Insert batteries	56
7.4	Install thermostatic head on hydraulic radiator	57
7.5	First startup of thermostatic head	57
7.6	First setup of thermostatic head	58
7.7	Register thermostatic heads in controller to rooms with a thermostat	59
7.8	Register thermostatic heads to controller in rooms without a thermostat	60
8	Install Uponor Smatrix Wave interface	62
8.1	Placement of interface	62
8.2	Attach the interface to the wall	62
8.3	Attach to table stand	63
8.4	Charger cable	63
8.5	Startup guide	63
9	Finishing installation	67
10	Operate Uponor Smatrix Wave controller	68
10.1	Principle of operation	68
10.2	Normal operation without optional scheduling programs	68
10.3	Operation with scheduling programs	68
10.4	Run mode	68
10.5	Reset the controller	69
10.6	Unregister channels in the controller	69
10.7	Update controller software (optional)	70
11	Operate Uponor Smatrix Wave analogue thermostats	71
11.1	Thermostat layout	71
11.2	Adjust temperature	72
11.3	Disable timer function (T-163 and T-165 only)	73
11.4	Replace batteries	73
11.5	Factory reset	74
12	Operate Uponor Smatrix Wave digital thermostats	75
12.1	Thermostat layout	75
12.2	Display layout	76
12.3	Operating buttons	79
12.4	Start up	80
12.5	Adjust temperature	81
12.6	Run mode	82
12.7	Control mode	82
12.8	Change control mode	83
12.9	Settings	83
12.10	Replace batteries	89
12.11	Factory reset	89
13	Operate Uponor Smatrix Wave thermostatic head	90
13.1	Thermostat layout	90
13.2	Display layout	90
13.3	Operating buttons	91
13.4	Start up	91
13.5	Adjust temperature	91
13.6	Run mode	91
13.7	Settings	92
13.8	Replace batteries	92
13.9	Factory reset	92

14	Operate Uponor Smatrix Wave interface.....	93
14.1	Touch screen.....	93
14.2	Home screen.....	93
14.3	Navigating the menu system	94
14.4	Adjust temperature.....	95
14.5	Room information.....	96
14.6	Main menu	98
14.7	System settings	99
14.8	Holiday.....	100
14.9	Heating/Cooling.....	101
14.10	Integration.....	101
14.11	Trends.....	102
14.12	System info.....	103
14.13	Preferences.....	103
14.14	Alarms	104
14.15	ECO profiles (scheduling)	104
14.16	MicroSD card.....	106
14.17	Factory reset of the interface.....	107
15	Maintenance	108
15.1	Manual preventive maintenance.....	108
15.2	Automatic preventive maintenance	108
15.3	Corrective maintenance	108
15.4	Controller LEDs.....	109
15.5	Restore from backup	110
16	Troubleshooting	111
16.1	Troubleshooting after installation.....	113
16.2	Digital thermostats T-166, T-168 and T-169 alarms/problems.....	113
16.3	Analogue thermostats T-161, T-163 and T-165 alarms/problems.....	115
16.4	Thermostatic head T-162 alarms/problems.....	115
16.5	Controller alarms/problems	116
16.6	Contact the installer	116
16.7	Installer instructions	116
17	Technical data.....	117
17.1	Technical data.....	117
17.2	Technical specifications	119
17.3	Controller layout.....	119
17.4	Wiring diagrams.....	120
17.5	Dimensions.....	121
18	Installation report	123
18.1	Controller 1	124
18.2	Controller 2	125
18.3	Controller 3	126
18.4	Controller 4	127

1 Copyright and disclaimer

Uponor has prepared this installation and operation manual and all the content included solely for information purposes. The contents of the manual (including graphics, logos, icons, text, and images) are copyrighted and protected by worldwide copyright laws and treaty provisions. You agree to comply with all copyright laws worldwide in your use of the manual. Modification or use of any of the contents of the manual for any other purpose is a violation of Uponor's copyright, trademark and other proprietary rights.

The presumption for the manual is that the safety measures have been fully complied with and, further, that Uponor Smatrix Wave, including any components that are part of such system, covered by the manual:

- is selected, planned and installed and put into operation by a licensed and competent planner and installer in compliance with current (at the time of installation) installation instructions provided by Uponor as well as in compliance with all applicable building and plumbing codes and other requirements and guidelines;
- has not been (temporarily or continuously) exposed to temperatures, pressure and/or voltages that exceed the limits printed on the products or stated in any instructions supplied by Uponor;
- remain in its originally installed location and is not repaired, replaced or interfered with, without prior written consent of Uponor;
- is connected to potable water supplies or compatible plumbing, heating and/or cooling products approved or specified by Uponor;
- is not connected to or used with non-Uponor products, parts or components except for those approved or specified by Uponor; and
- does not show evidence of tampering, mishandling, insufficient maintenance, improper storage, neglect or accidental damage before installation and being put into operation.

While Uponor has made efforts to ensure that the manual is accurate, Uponor does not guarantee or warrant the accuracy of the information contained herein. Uponor reserves the right to modify the specifications and features described herein, or discontinue manufacture of Uponor Smatrix Wave described at any time without prior notice or obligation. The manual is provided "as is" without warranties of any kind, either expressed or implied. The information should be independently verified before using it in any manner.

To the fullest extent permissible, Uponor disclaims all warranties, expressed or implied, including, but not limited to, the implied warranties of merchantability, fitness for particular purpose and non-infringement.

This disclaimer applies to, but is not limited to, the accuracy, reliability or correctness of the manual.

Under no circumstances shall Uponor be liable for any indirect, special, incidental or consequential damages or loss that result from the use of or the inability to use the materials or information in the manual, or any claim attributable to errors, omission or other inaccuracies in the manual, even if Uponor has been advised of the possibility of such damages.

This disclaimer and any provisions in the manual do not limit any statutory rights of consumers.

2 Preface

This installation and operation manual describes how to install and operate the components of the system.

2.1 Safety instructions

Warnings used in this manual

The following symbols are used in the manual to indicate special precautions when installing and operating any Uponor equipment:



WARNING!

Risk of injury. Ignoring warnings can cause injury or damage components.



CAUTION!

Ignoring cautions can cause malfunctions.

Safety measures

Conform to the following measures when installing and operating any Uponor equipment:

- Read and follow the instructions in the installation and operation manual.
- Installation must be performed by a competent person in accordance with local regulations.
- It is prohibited to make changes or modifications not specified in this manual.
- All power supplies must be switched off before starting any wiring work.
- Do not use water to clean Uponor components.
- Do not expose the Uponor components to flammable vapours or gases.

Uponor cannot accept any responsibility for damage or breakdown that can result from ignoring these instructions.

Power



WARNING!

The Uponor system uses 50 Hz, 230 V AC power. In case of emergency, immediately disconnect the power.

Technical constraints



CAUTION!

To avoid interference, keep installation/data cables away from power cables of more than 50 V.

2.2 Limitations for radio transmission

The Uponor system uses radio transmission. The frequency used is reserved for similar applications, and the chances of interference from other radio sources are very low.

However, in some rare cases, it might not be possible to establish perfect radio communication. The transmission range is sufficient for most applications, but each building has different obstacles affecting radio communication and maximum transmission distance. If communication difficulties exist, Uponor recommends relocating the antenna to a more optimal position, and not installing Uponor radio sources too close to each other (**at least 40 cm apart**), for solving exceptional problems.

2.3 Correct disposal of this product (Waste Electrical and Electronic Equipment)



NOTE!

Applicable in the European Union and other European countries with separate collection systems



This marking shown on the product or its literature indicates that it should not be disposed with other household waste at the end of its working life. To prevent possible harm to the environment or human health from uncontrolled waste disposal, please separate this from other types of wastes and recycle it responsibly to promote the sustainable reuse of material resources.

Household users should contact either the retailer where they purchased this product, or their local government office, for details of where and how they can take this item for environmentally safe recycling.

Business users should contact their supplier and check the terms and conditions of the purchase contract. This product should not be mixed with other commercial wastes of disposal.

3 Uponor Smatrix Wave

Uponor Smatrix Wave is a management system for underfloor heating and cooling installations. Comfort, user friendliness and temperature control for each individual room of a home can be combined through the various components.

3.1 System overview

Uponor Smatrix Wave consists of a controller, an interface (optional), thermostats, and actuators. The controller manages the operation of the actuators when the thermostats detect a demand for heating or cooling.

The controller can also manage the room temperature in rooms with radiators using wireless thermostatic heads.

The interface facilitates system optimization and settings for up to four controllers. The system can function without the interface, but with reduced functionality.

Uponor Smatrix Wave is controlled by different types of thermostats. Designed for maximum comfort, the thermostats communicate with the controller by radio link. It is possible to mix the different types of Uponor Smatrix Wave thermostats in the same installation.

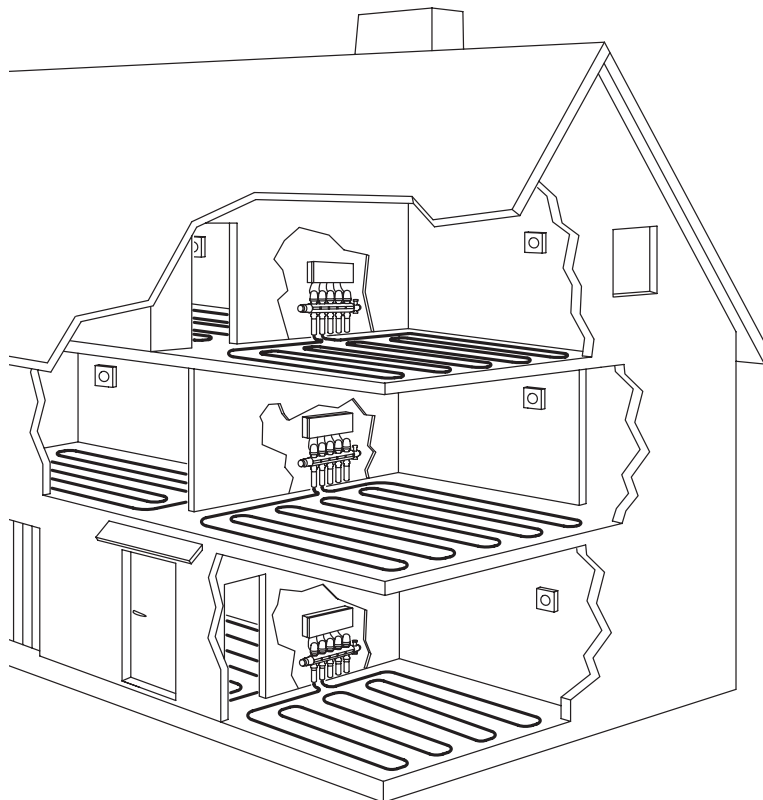

3.2 Example of a system

The illustration below shows Uponor Smatrix Wave with several installation options and thermostats.

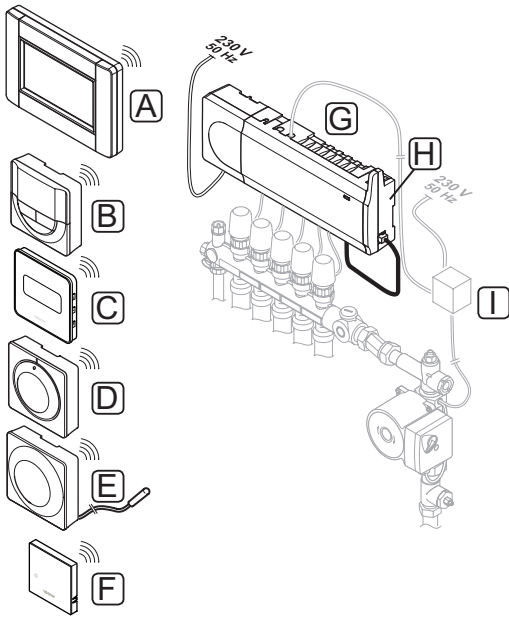

Item	Description
A	Uponor Smatrix Wave I-167 (interface I-167)
B	Uponor Smatrix Wave T-168 (programmable digital thermostat with RH T-168)
C	Uponor Smatrix Wave T-169 (digital thermostat with RH T-169)
D	Uponor Smatrix Wave T-165 (standard thermostat T-165)
E	Uponor Smatrix Wave T-163 (public thermostat T-163) with floor sensor
F	Uponor Smatrix Wave T-161 (room sensor thermostat)
G	Uponor Smatrix Wave X-165 (controller X-165)
H	Uponor Smatrix Wave A-165 (antenna A-165)
I	External connection box for pumps (third-party product, just schematic example in illustration)

NOTE!

The floor sensor can be connected to thermostats T-161, T-163, T-166, T-168 and T-169. Floor temperature limitation together with thermostats T-161 or T-163 can only be done in a Wave system using an interface.

For example, the maximum limitation can protect a sensitive floor covering from exposure of too high temperature when there is a high heating demand. The minimum limitation can keep a tiled floor warm even when there is a no general demand for heat supply to the room.

3.3 Uponor Smatrix Wave components

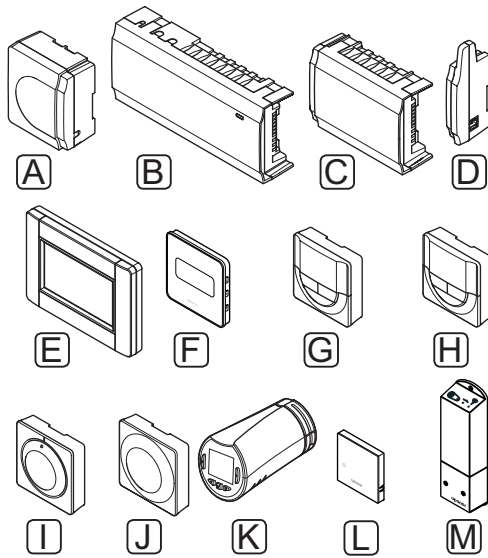

Pos.	Uponor designation	Description
A	Uponor Smatrix A-1XX (transformer A-1XX)	Transformer module
B	Uponor Smatrix Wave X-165 (controller X-165)	Controller
C	Uponor Smatrix Wave M-160 (slave module M-160)	Slave module
D	Uponor Smatrix Wave A-165 (antenna A-165)	Antenna
E	Uponor Smatrix Wave I-167	Interface
F	Uponor Smatrix Wave T-169	Digital thermostat with relative humidity sensor and operative sensor
G	Uponor Smatrix Wave T-168	Programmable digital thermostat with relative humidity sensor
H	Uponor Smatrix Wave T-166	Digital thermostat
I	Uponor Smatrix Wave T-165	Standard thermostat with print on dial
J	Uponor Smatrix Wave T-163	Public thermostat
K	Uponor Smatrix Wave T-162 (thermostatic head T-162)	Thermostatic head
L	Uponor Smatrix Wave T-161 (room sensor thermostat)	Room sensor thermostat with relative humidity sensor and operative sensor
M	Uponor Smatrix Wave M-161 (relay module M-161)	Relay module

CONTROLLER

The controller operates the actuators, which in turn affect the flow of the supply water, to change the indoor temperature using information transmitted from registered thermostats and system parameters.

Up to six channels and eight actuators can be operated by the controller, which is typically located near the hydraulic system manifolds.

The illustration below shows the controller with the transformer module, antenna and actuators.

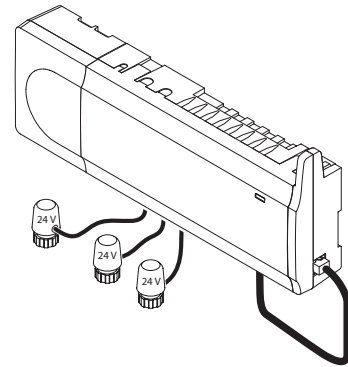

CAUTION!

Only 24 V Uponor actuators are compatible with the controller.

Uponor Smatrix Wave X-165

Main characteristics:

- Integrated Dynamic Energy Management functions such as autobalancing (on by default). Other functions such as comfort setting, room bypass, and supply temperature monitoring requires an interface.
- Electronic control of actuators.
- Connection of maximum eight actuators (24 V).
- 2-way communication with up to six room thermostats.
- Heating/cooling function (advanced), and/or Comfort/ECO mode switched by dry contact, public thermostat or touch panel interface.
- Separate relays for control of pump and boiler.
- Integrated heat pump module (only available in selected countries, contact a local Uponor office for more information).
- Smart Home Gateway connectivity via touch screen. *See separate documentation.*
- Valve and pump exercise.
- Logging, back up and updates via microSD card.
- Relative humidity control (interface require to change limits).
- Control of combined underfloor heating/cooling and ceiling cooling (requires an interface).
- Lower indoor temperature with ECO mode. Use an interface I-167 or public thermostat T-163 (with Comfort/ECO switch) to activate ECO mode in all rooms at once. Use a digital thermostat T-168 to activate ECO mode in a single room.

Options:

- The controller can be expanded with a slave module which adds an extra six channels and six actuator outputs.
- Connect up to four controllers into one system (requires an interface).
- Modular placement (detachable transformer and antenna).
- Cabinet or wall mounted (DIN rail or supplied screws).
- Free placement and orientation when installing the controller (except the antenna which must be installed vertically).

Components of the controller

The illustration below shows the controller and its components.

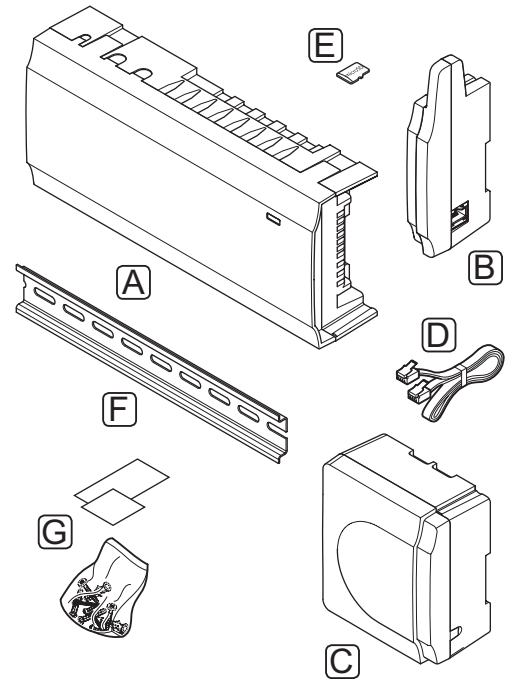

Item	Description
A	Uponor Smatrix Wave X-165
B	Antenna
C	Transformer
D	Antenna connection cable
E	MicroSD card
F	DIN rail
G	Mounting material

INTERFACE (OPTIONAL)

Uponor Smatrix Wave I-167 is a touch screen interface that can be connected through radio transmission to controller X-165.

The interface acts as a link between the user and the controller(s) running in the system, displaying information and enabling simplified programming of all relevant system settings. It can also be detached from the wall for easy use on other locations more comfortable (e.g. couch).

The Uponor Smatrix Wave system can be operated without the interface, but with reduced functionality (in example: many of the main characteristics listed below cannot be used).



NOTE!

Uponor Smatrix Wave systems without an interface can only operate with reduced functionality.

Uponor Smatrix Wave I-167

Main characteristics:

- Touch screen interface.
- Display information and change settings of up to four controllers running within one system.
- Adjust temperature setpoints of registered thermostats within the system.
- Installation setup wizard when installed for the first time or after a factory reset.
- User friendly menu system available in several different languages.
- Backlit display.
- Temperature setback programs for each connected thermostat.
- Limitations of maximum/minimum temperature.
- Schedule temporary lowering of setpoint during holiday.
- Automatic change between summer- and winter time.
- Diagnostic function detecting if a room thermostat is installed in the right room (room check).
- Possibility to automatically open up to two rooms per controller when other rooms are closed to maintain a minimum flow (room bypass).
- System diagnostic (alarms etc).
- Visualize trends by e.g. comparing setpoint with room temperature etc.

- Advanced cooling settings.
- Change language and/or update the software with microSD card.
- Smart Home Gateway connectivity (requires a remote module).
- Control of accessories (outputs etc).

Components of the interface

The illustration below shows the interface and its components.

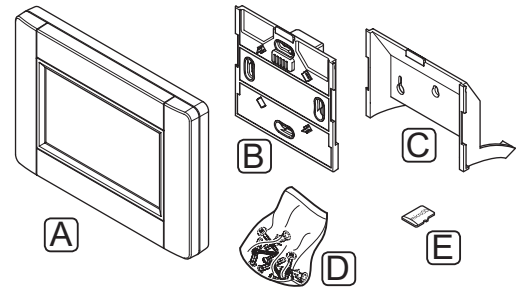

Item	Description
A	Uponor Smatrix Wave I-167
B	Wall bracket with power supply
C	Table stand
D	Mounting material
E	MicroSD card

THERMOSTATS

The thermostats communicate with the controller through radio transmissions and are used either individually or in combination with each other.

The following Uponor Smatrix thermostats can be used in the system:

Thermostat
Uponor Smatrix Wave T-169*
Uponor Smatrix Wave T-168*
Uponor Smatrix Wave T-166*
Uponor Smatrix Wave T-165
Uponor Smatrix Wave T-163
Uponor Smatrix Wave T-161*

* With reduced functionality



NOTE!

The thermostat is affected by the temperature of the surrounding surfaces as well as the ambient air temperature.

Uponor Smatrix Wave T-169

The thermostat shows the ambient, set temperature or relative humidity on the display. Temperature settings are adjusted using the +/- buttons on the front.

Main characteristics:

- Power saving e-paper display (updates every 10 minutes).
- Displays Celsius or Fahrenheit.
- Operative sensor for increased comfort.
- Calibration of displayed room temperature.
- Heating/cooling demand as well as low battery indication on display.
- Displays Uponor logo and software version during power up sequence.
- Setpoint range is 5 – 35 °C (maximum and minimum setting may be limited by other system settings).
- Room temperature regulation with use of optional external temperature sensors.
- Displays optional temperature sensor values if sensors are connected and relevant room temperature regulation is activated.
- Switch between Comfort and ECO mode with optional timer.
- Adjust ECO setback value.
- Relative humidity limit indicated in display.
- Invert display color.
- Can be placed up to 30 meters away from the controller.

Components of the thermostat:

The illustration below shows the thermostat and its components.

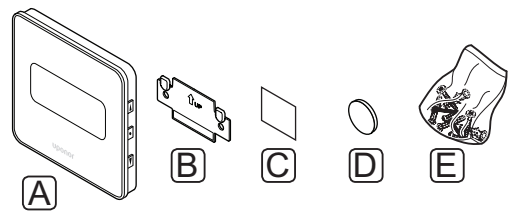

Item	Description
A	Uponor Smatrix Wave T-169
B	Wall bracket
C	Adhesive tape
D	Battery (CR2032 3V)
E	Mounting material

Uponor Smatrix Wave T-168

The thermostat shows the ambient, set temperature or relative humidity, and time on the display. Settings are adjusted using the +/- buttons on the front. Other programmable settings are scheduling and individual ECO mode (on a room by room basis) etc.

Uponor recommends only using this thermostat in systems without an interface (optional). The scheduling function in the thermostat is switched off in systems with an interface.

Main characteristics:

- Backlit display, dims after 10 seconds of inactivity.
- Displays Celsius or Fahrenheit.
- Calibration of displayed room temperature.
- Heating/cooling demand as well as low battery indication on display.
- Displays software version during power up sequence.
- Setup wizard to set time and date when installed for the first time or after a factory reset.
- 12/24h clock for scheduling.
- Setpoint range is 5 – 35 °C (maximum and minimum setting may be limited by other system settings).
- Room temperature regulation with use of optional external temperature sensors.
- Displays optional temperature sensor values if sensors are connected and relevant room temperature regulation is activated.
- Programmable to switch between Comfort and ECO modes with adjustable ECO setback value in the room.
- When set to a program the T-168 cannot be overridden (ECO setback etc) by other thermostats.

- Relative humidity limit indicated in display.
- Scheduling, pre-programmed and customizable schedules.
- Lower indoor temperature on a room by room basis with ECO mode.
- Can be placed up to 30 meters away from the controller.

Components of the thermostat:

The illustration below shows the thermostat and its components.

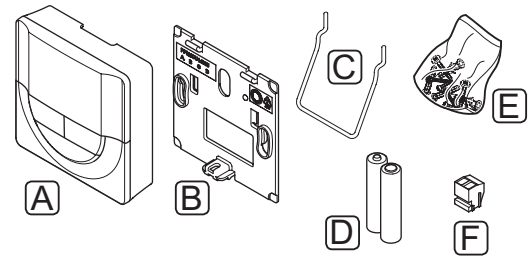

Item	Description
A	Uponor Smatrix Wave T-168
B	Wall bracket
C	Stand
D	Batteries (AAA 1.5 V)
E	Mounting material
F	Connection terminal

Uponor Smatrix Wave T-166

The thermostat shows the ambient or set temperature on the display. Temperature settings are adjusted using the +/- buttons on the front.

Main characteristics:

- Backlit display, dims after 10 seconds of inactivity.
- Displays Celsius or Fahrenheit.
- Calibration of displayed room temperature.
- Heating/cooling demand as well as low battery indication on display.
- Displays software version during power up sequence.
- Setpoint range is 5 – 35 °C (maximum and minimum setting may be limited by other system settings).
- Room temperature regulation with use of optional external temperature sensors.
- Displays optional temperature sensor values if sensors are connected and relevant room temperature regulation is activated.
- Switch between Comfort and ECO mode with optional timer.
- Adjust ECO setback value.
- Can be placed up to 30 meters away from the controller.

Components of the thermostat:

The illustration below shows the thermostat and its components.

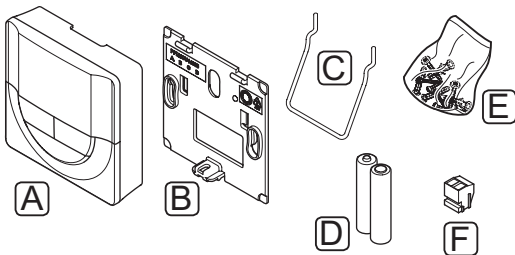

Item	Description
A	Uponor Smatrix Wave T-166
B	Wall bracket
C	Stand
D	Batteries (AAA 1.5 V)
E	Mounting material
F	Connection terminal

Uponor Smatrix Wave T-165

The thermostat temperature settings are adjusted using the dial. Maximum/minimum temperatures can only be set using an interface (optional). The 21 °C position is marked on the dial.

Main characteristics:

- Adjust temperature setpoint with large dial.
- LED ring indication when twisting the dial (changing temperature setpoint).
- Setpoint range is 5 – 35 °C (maximum and minimum setting may be limited by other system settings).
- LED in lower right corner indicating, for about 60 seconds, whether a heating or cooling demand exists.
- Enable or disable Comfort/ECO scheduling for the room with a dip switch on the back.
- Can be placed up to 30 meters away from the controller.

Components of the thermostat:

The illustration below shows the thermostat and its components.

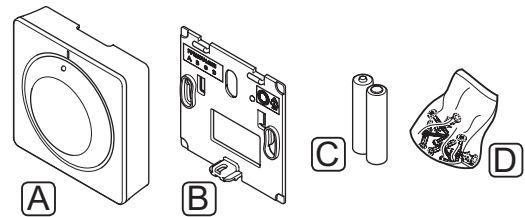

Item	Description
A	Uponor Smatrix Wave T-165
B	Wall bracket
C	Batteries (AAA 1.5 V)
D	Mounting material

Uponor Smatrix Wave T-163

The thermostat is designed for public locations which means that the dial is hidden. It must be removed from the wall to set the temperature. When it is removed, an alarm is triggered (if activated).

The thermostat can be registered as a system device, enabling extra functions. When functioning as a system device, the internal room sensor is disabled.

Main characteristics:

- Adjust setpoint temperature with a potentiometer on the back of the thermostat.
- Setpoint range is 5 – 35 °C (maximum and minimum setting may be limited by other system settings).
- Alarm is indicated on the controller if removed from wall for tamper detection. If an interface (optional) is installed, it will display the alarm as well.
- Dry contact input for switching operation modes between heating and cooling, if registered as a system device.
- Dry contact input for forced ECO mode of operation, if registered as a system device.
- Optional external temperature sensor can be connected to the thermostat. Floor temperature limitation (maximum and minimum) is only available in a Wave system with an interface I-167.
- Optional outdoor temperature sensor can be registered as either standard thermostat or system device.
- Dip switch for selecting between function or sensor mode of operation.
- Enable or disable Comfort/ECO scheduling for the room with a dip switch on the back.
- Can be placed up to 30 meters away from the controller.

Components of the thermostat:

The illustration below shows the thermostat and its components.

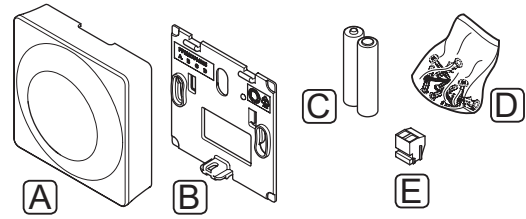

Item	Description
A	Uponor Smatrix Wave T-163
B	Wall bracket
C	Batteries (AAA 1.5 V)
D	Mounting material
E	Connection terminal

Uponor Smatrix Wave T-161

The thermostat is designed to be as small as possible, and still able to control the room temperature.

Main characteristics:

- Operative sensor for increased comfort.
- Adjust setpoint temperature via the Wave interface I-167.
- Setpoint range is 5 – 35 °C (maximum and minimum setting may be limited by other system settings).
- Optional floor temperature sensor can be connected to the thermostat. Floor temperature limitation (maximum and minimum) is only available in a Wave system with an interface I-167.
- Relative humidity limit indicated in display via the Wave interface I-167.
- Can be placed up to 30 meters away from the controller.

Components of the thermostat:

The illustration below shows the thermostat and its components.

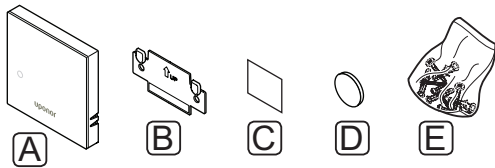

Item	Description
A	Uponor Smatrix Wave T-161
B	Wall bracket
C	Adhesive tape
D	Battery (CR2032 3V)
E	Mounting material

THERMOSTATIC HEAD

Uponor Smatrix Wave T-162

The thermostatic head enables control of radiators in the system.

Main characteristics:

- Proportional control
- Backlit display, dims after 10 seconds of inactivity.
- Displays Celsius or Fahrenheit.
- Displays software version during power up sequence.
- Receives setpoint and Comfort/ECO mode from thermostat and interface, if available. The setpoint is otherwise set on the thermostatic head.
- Setpoint range is 5 – 35 °C (maximum and minimum setting may be limited by other system settings).
- Shows current room temperature.
- Requires an Uponor Smatrix Wave controller.
- One to several thermostatic heads per room can be registered. Up to two thermostatic heads per channel.
- Can be placed up to 30 meters away from the controller.

Components of the thermostatic head:

The illustration below shows the thermostatic head and its components.

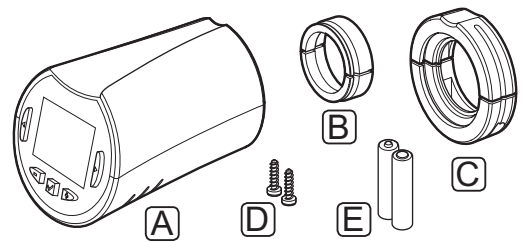

Item	Description
A	Uponor Smatrix Wave T-162
B	Adaptors (threaded M30 and M28)
C	Plastic fitting brackets
D	Mounting screws
E	Batteries (AA 1.5 V)

SLAVE MODULE**Uponor Smatrix Wave M-160**

The slave module adds six channels and actuator outputs to an existing Uponor Smatrix Wave controller.

Main characteristics:

- Easy plug in installation on existing controller, no additional wiring needed.
- Register up to six extra thermostats to the system.
- Connect up to six extra actuators (24 V).
- Electronic control of actuators.
- Valve exercise.

**NOTE!**

Only one slave module extension is supported per controller.

Components of the slave module:

The illustration below shows the slave module and its components.

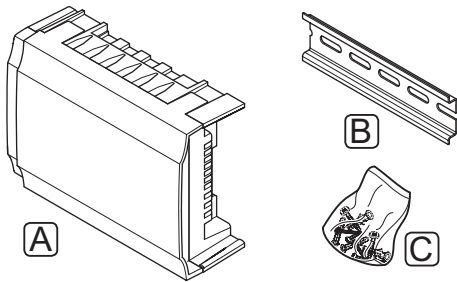

Item	Description
A	Uponor Smatrix Wave M-160
B	DIN rail
C	Mounting material

RELAY MODULE**Uponor Smatrix Wave M-161**

The relay module adds two extra output relays to the system.

Main characteristics:

- Potential free contacts (230 V AC, 5 A).
- Requires an Uponor Smatrix Wave controller.
- Pump control and heating/cooling output function.
- Pump and dehumidifier control function (requires interface).
- Boiler and chiller control function (requires interface).
- Optional two stage cooling function (requires activation on the relay module).
- Can be placed up to 30 meters away from the controller.

Components of the relay module:

The illustration below shows the relay module and its components.

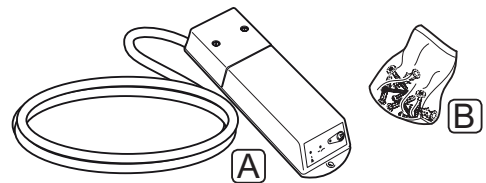

Item	Description
A	Uponor Smatrix Wave M-161
B	Mounting material

UPONOR ACTUATORS

Uponor actuators are mounted on top of the manifold valves and is operated using either on/off signals or pulse width modulation (PWM) signals.

On/off control

When installing a system with on/off control, manual balancing of the system is required.

As soon as the temperature measured at a thermostat is lower (heating mode) or higher (cooling mode) than the setpoint temperature, a demand to change the room temperature is created and sent to the controller. The controller will open the actuators according to current operating mode and other settings. Once the set temperature is reached, this information is sent and the actuators are closed. The indicator window on the actuator shows, with a white bar, how much it is opened. If the window is completely filled with white it is fully opened, no white bar shown means that the actuator is closed.

Time to open and close an actuator is 1 minute.

PWM control

PWM control is used when the Autobalancing function is active.

When installing a system with PWM control, all balancing valves can be fully opened, the system is balanced automatically.

NOTE! Autobalancing can be used in combination with hydronic balancing.

See section 3.5 Functions > Autobalancing for more information.

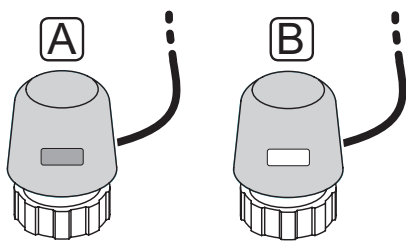

- A Actuator has closed the valve – empty indicator
- B Actuator has opened the valve – white indicator

3.4 Accessories

Uponor offers a wide variety of accessories for use with the standard portfolio.

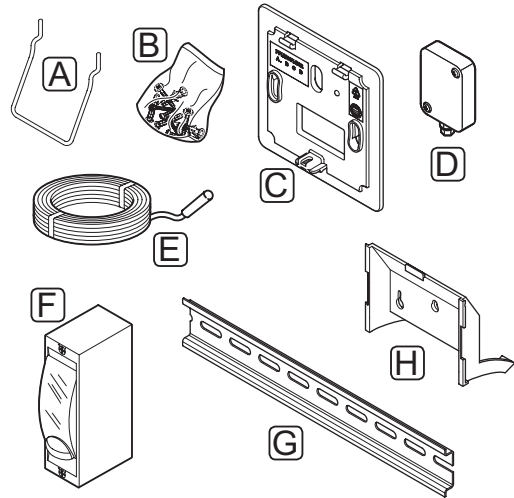

NOTE! Some of these accessories may be included in the system.

Item	Component	Description
A	Attachment options for thermostats	Table stand
B	T-163, T-165, T-166, and T-168	Screws
C	Uponor Smatrix T-X A-1XX (wallframe T-X A-1XX)	Wall frame for covering larger area of the wall than original back plate. Used at installation of thermostats T-163, T-165, T-166, and T-168
D	Uponor Smatrix S-113 (outdoor sensor S-113)	Outdoor sensor for use with thermostats T-163, T-166, T-168 and T-169
E	Uponor Smatrix S-114 (floor/remote sensor S-114)	Floor/remote sensor for use with thermostats T-161, T-163, T-166, T-168 and T-169
F	Uponor Heating/Cooling relay	Relay for connecting external voltage signal from a heating/cooling source, such as a heat pump, to a controller input.
G	DIN rail	DIN rail for use with Uponor Smatrix Wave controllers
H	Table stand for interface I-167	Table stand for use with interface I-167

3.5 Functions

Uponor Smatrix Wave is used to control an underfloor heating and/or cooling system in a house.

The controller can also control heating via radiators using thermostatic heads.

The thermostats registered to the controller is used to control the actuators mounted on top of the manifold valves.

As soon as the temperature measured at a thermostat is lower (heating mode) or higher (cooling mode) than the setpoint temperature, a demand to change the room temperature is created and sent to the controller. The controller will operate the actuators according to current control mode and settings. This will manage the flow to the floor loops in the room and adjust the room temperature. Once the set temperature is reached, this information is sent to the controller and the demand is met.

COMFORT AND ECO MODES

If a timer is connected to the controller, it is possible to regulate the temperature setpoint modes between three different temperatures. Available modes is **Comfort**, **ECO** (economy), and **Holiday**. See *example of Comfort and ECO mode below*.

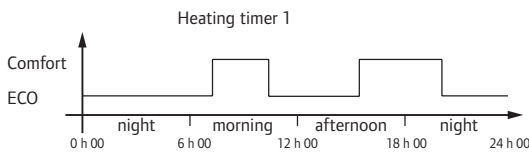

The diagram shows that the system delivers heating in comfort mode in the morning and afternoon, but the system enters ECO mode during night and in the middle of the day, when the house normally is empty.

AUTOBALANCING



NOTE!

Autobalancing can be used in combination with hydronic balancing.

The Uponor Smatrix Wave controller can operate the actuator outputs by either on/off signals or by Autobalancing (on by default), using pulse width modulation (PWM) signals.

Autobalancing is a function where the system calculates the actual energy need of single rooms and adapts the output power of each loop to its length. This means a short loop might get 20% on time while a long loop might get about 60%.

The automatic balancing continues through the seasons and throughout the household's changing lifestyle and usage patterns, removing the need of manual balancing.

This gives more even floor temperatures and faster system reaction times with lower energy consumption than any standard on/off system.

LOW HYSTERESIS TEMPERATURE

Uponor uses a low hysteresis temperature for best performance of the system. It is used for high control accuracy by deciding when to start and stop heating and cooling, based on information from sensors and setpoint values.

HEATING/COOLING OFFSET

Uponor uses an offset temperature to adjust the setpoints when switching between heating and cooling. This improves the performance of the system and reduces the need of manual setpoint adjustments when switching between heating and cooling.

The offset is 2 °C and is used to increase the setpoints when switching to cooling. When switching back to heating, the value is used to reduce the setpoint.

TWO STAGE ADDITIONAL COOLING FUNCTION

Using the relay module M-161, and a digital thermostat, an optional second cooling stage can be connected to the Wave controller.

Using one of the relays, activation of the second cooling stage is delayed either 30 minutes (relay 1) or 90 minutes (relay 2).

RELATIVE HUMIDITY FUNCTION

To avoid condensation when having a cooling system, it is recommended measuring the relative humidity (RH) in the rooms. The relative humidity is measured with one or more thermostats (with RH sensor).

Uponor Smatrix Wave without interface I-167

Cooling is shut off for the whole system if the RH reaches a "worst case level" of 80% in one of the thermostats (if more than one).

Cooling will start again when the relative humidity falls below 76%.

Uponor Smatrix Wave with interface I-167

Cooling is shut off on a per room basis when the relative humidity limit is reached (set in the interface, default 75%). If a dehumidifier is installed, one per controller using a relay module, it will be activated when the dehumidifier start limit is reached.

Cooling will start again and the dehumidifier is deactivated when the relative humidity falls below a hysteresis set in the interface ("Deadzone", default 5%).

PUMP MANAGEMENT (REQUIRES INTERFACE I-167)

Each controller in a system has a pump relay, to which one pump can be connected. If a pump is connected, it is automatically set in common mode. Use the interface to change the setting if needed. Available settings are **Common**, **Individual** and **H/C switch**.

Common mode:

Relay status is set on a system wide basis. One pump per system is connected (to the master controller only). If there is a demand in one room of the controllers, the main pump is started.

Individual mode:

Relay status is set on a controller basis. One pump per controller is connected. If there a demand in a room, only the pump connected to that controller is started.

H/C-switch:

Use the relay as a heating/cooling output. A circulation pump cannot be connected to the controller using the **PUMP** connector.

If more than one controller is available in the system, and the circulation pump settings in the interface is set to **Common**. The **PUMP** connector on the other controllers can be used for heating/cooling output signal.

Relay module (optional):

When using relay module M-161 to control a pump, the mode of the pump control is set through the interface.

ACTUATOR MANAGEMENT

Actuator management prevents too many actuators to be open at the same time in order to reduce the peak power need. Peak current can be reduced by delaying the opening of some actuators, as they use most current while being opened.

Up to eight actuators in up to six rooms can be opened at the same time. Additional actuators are queued and opened in order.

HEATING FALL BACK

If the connection to a thermostat is lost, the corresponding loop cannot be regulated using the room temperature. The controller then activates a fall back function for the affected loop and the actuators are operated with a set interval.

The function is activated until the thermostat is reconnected.

SYSTEM CLOCK

To facilitate accurate log data, scheduling and different timer settings, the controller receives the correct time and date from one of the input devices (interface, programmable thermostat etc). The clock can be set to automatically switch between summer and winter time (Wave with an interface only).

MICROSD CARD

Uponor Smatrix Wave uses a microSD card for cloning (interface settings), automatic backup (settings and thermostat registration data), manual restoration of backup, data logging (room data, controller data, system data and events) and upgrading software.

HEAT PUMP INTEGRATION (OPTIONAL, REQUIRES INTERFACE I-167)

The controller can connect to selected heat pumps and adjust the supply temperature to the system.

This function is only available in selected countries, contact a local Uponor office for more information.

See heat pump documentation for more information.

ROOM CHECK (REQUIRES INTERFACE I-167)

Room check is a diagnostic function detecting whether a room thermostat is installed in the right room.

See section 14.7 Settings > Room check for more information.

ROOM BYPASS (REQUIRES INTERFACE I-167)

Up to a maximum of two rooms, for each controller, can be selected to act as a bypass in the system.

See section 14.7 Settings > Room bypass for more information.

4 Install Uponor Smatrix Wave

4.1 Installation procedure

UPONOR SMATRIX WAVE

Uponor recommends following the process described below to guarantee the best possible installation results.

Stage	Procedure	Page
1	Prepare for installation	21
2	Install Uponor Smatrix Wave controller	25
3	Connect a slave module (optional)	27
4	Install Uponor Smatrix Wave thermostats and sensors	45
5	Install Uponor Smatrix Wave interface (optional)	62
6	Install Uponor Smatrix Wave thermostatic head	56
7	Register Uponor Smatrix Wave Relay Module M-161	44
8	Finish installation	67

UPONOR SMATRIX WAVE INTERFACE I-167

Follow the process described below to install the Uponor Smatrix Wave Interface I-167.

Stage	Procedure	Page
1	Placement of interface	62
2	Startup guide	63

4.2 Prepare for installation

Before starting the installation:

- Verify the contents of the package with the packing list.
See also section 3.3 Uponor Smatrix Wave components for identification of components.
- Check whether an external temperature sensor is to be installed with a compatible thermostat.
- Study the wiring diagram in the end of this manual or inside the controller cover.

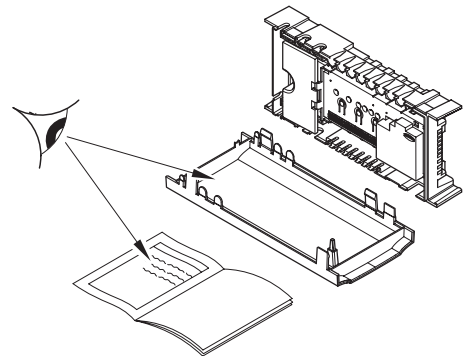
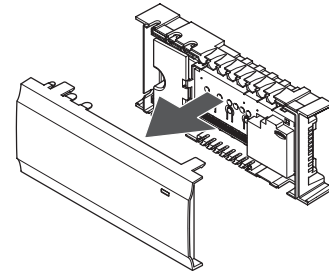

To determine where to best place the Uponor Smatrix Wave components, follow these guidelines:

- Ensure that the controller can be installed close to the manifold pair. Note that each manifold pair must have its own controller.
- Ensure that the controller can be mounted close to a 230 V AC wall socket, or if required by local regulations, to a junction box, connected to the mains power.
- Ensure that installed Uponor Smatrix Wave components are protected from running or dripping water.

4.3 Installation example

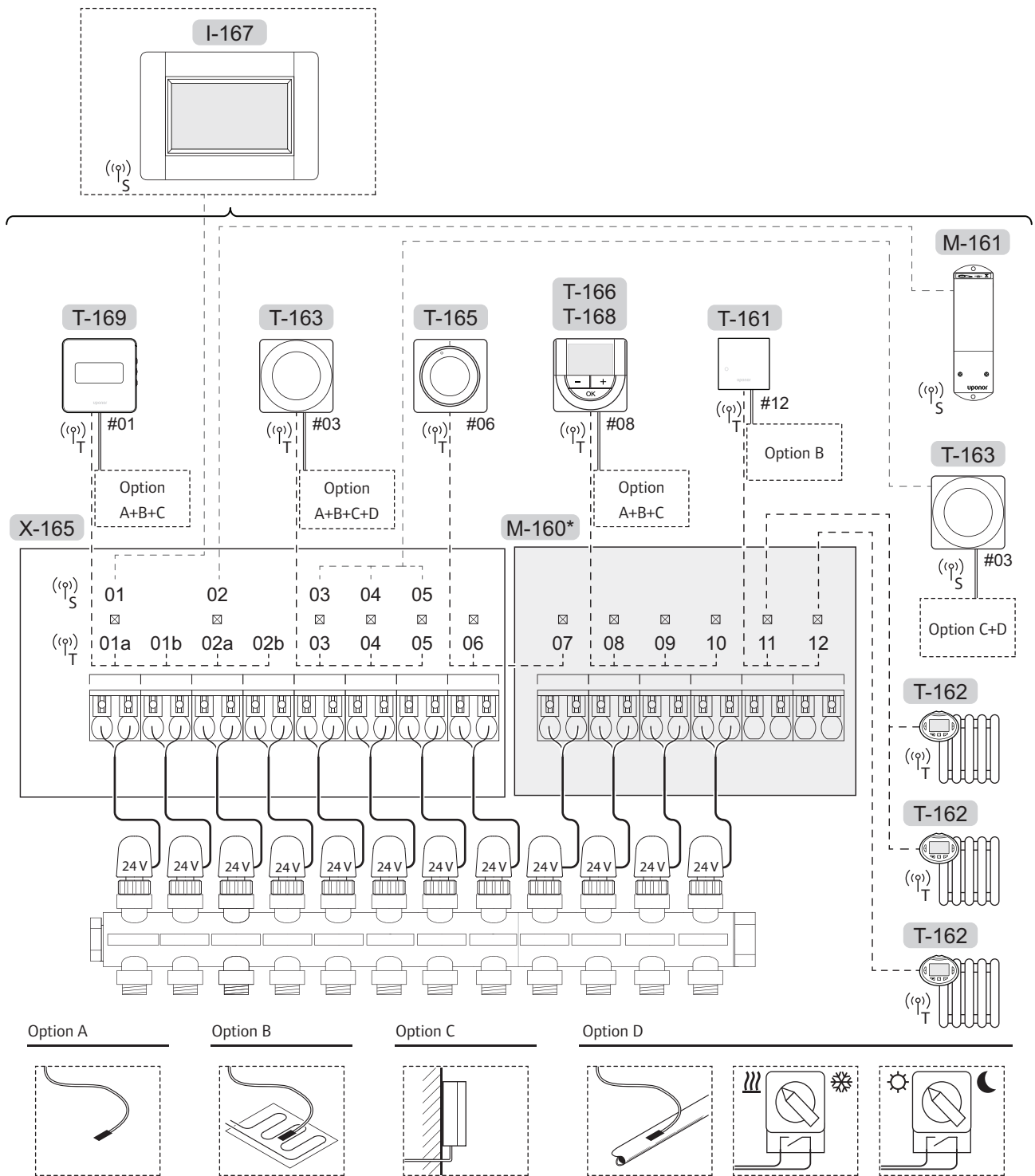

*) This example contains optional accessories which adds six actuator outputs (slave module M-160) to the Uponor Smatrix Wave controller

See also the wiring diagram in the end of the manual.



CAUTION!

Only 24 V Uponor actuators are compatible with the controller.

UPONOR SMATRIX WAVE SYSTEM

A connection example of Uponor Smatrix Wave Controller (six channels) with an optional Uponor Smatrix Wave Slave Module (six extra channels) using system devices (S) and thermostats (T) as shown in figure.

The installation will work in a standard way with the thermostats regulating each room according to their set temperatures.

Thermostats and actuators

- Thermostat #01 controls the actuators on channels 01a, 01b, 02a and 02b with the help of an option.
- Thermostat #03 controls the actuators on channels 03 to 05 with the help of an option.
- Thermostat #06 controls the actuators on channels 06 and 07.
- Thermostat #08 controls the actuators on channels 08 to 10 with the help of an option.
- Thermostat #11 controls the three thermostatic heads, and radiators, on channels 11 and 12.

System devices

- Interface I-167 (optional) controls the whole system and individual settings for each thermostat can be set. Schedules can be programmed for one or several thermostats instructing them when to switch between Comfort and ECO modes.
- Relay module M-161 with two extra output relays. *See section 3.3 Uponor Smatrix Wave components > Relay module for more information.*
- Public thermostat T-163 with various functions (options B and C).



NOTE!

If registering a public thermostat T-163 with various functions as a system device, the thermostat only acts as a remote unit. It does not control the room temperature in the room where it is placed.

Option A

- External temperature sensor.

Option B

- Floor temperature sensor.

Option C

- Outdoor temperature sensor.

Option D

- External temperature sensor for heating/cooling switch. This option cannot be combined with a heating/cooling switch, in the same system.
- Heating/cooling switch. This option cannot be combined with an external temperature sensor for heating/cooling switch, in the same system.
- Comfort/ECO mode switch.

Schedules

Programmable schedules can, during heating and/or cooling, switch between Comfort and ECO mode. See example below.

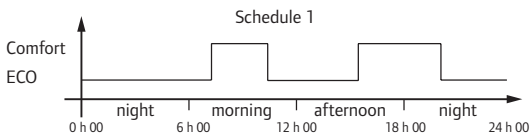

Other rooms can, depending on system setup, simultaneously switch between Comfort and ECO mode according to their own programmed schedules.

This requires one or more of the following:

- Uponor Smatrix Wave I-167 (optional)
The interface allows for system wide, or individually programmed, schedules for the rooms in the system. Any other devices with its own programmed schedules are overridden and its menus hidden.
- Uponor Smatrix Wave T-168
The thermostat is in control of its own room, with restrictions stated above, regarding the interface and timer.

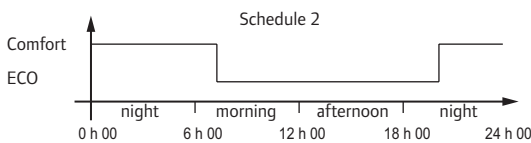

Even if programmed schedules exist in the system, some rooms may still operate without any scheduling. These rooms will operate in constant Comfort mode and is not affected by the programming of other rooms.

Room sensor T-161:

- Set the value in the interface I-167.

Public thermostat T-163:

- Set the switch on its back to comfort mode only.

Standard thermostat T-165:

- Set the switch on its back to comfort mode only.

Digital thermostats T-166 and T-169:

- Set the **ECO setback** value in menu **03** to **0**.

Digital thermostat T-168:

- Set the **ECO setback** value in menu **03** to **0** and menu **00** to **Off**.

Heating/cooling switch

The heating/cooling switch is manually controlled through the interface (which controls the whole system), a public thermostat or an external signal. It is used to switch the operation of the controller between heating and cooling modes.

The external signal can be connected to up to four Wave controllers, working in parallel. This reduces the number of heating/cooling switches needed in the system.

Distributed manifolds or single valve

If a manifold, or a valve of a single loop, is placed too far from the controller a relay module can be used.

1. Connect the actuator attached to the distributed manifold to a relay module (230V from the controller or 24V from an external power supply).
2. Register the digital thermostat to an empty channel on the Wave controller.
3. Use thermostat settings menu 09 on the same thermostat and register it to the relay module.

The manifold is now distributed and is using the same thermostat, autobalancing, and actuator management as the Wave controller for the selected channel.

5 Install Uponor Smatrix Wave controller

5.1 Placement of controller

Refer to the installation preparation guidelines (see section 4.2 *Prepare for installation*), and use the following guidelines when positioning the controller:

- Position the controller just above the manifold. Check the position of the 230 V AC wall socket, or if required by local regulations, to a junction box, connected to the mains power.
- Check that the cover of the controller can be easily removed.
- Check that connectors and switches are easily accessible.

MODULAR PLACEMENT

The controller is designed with the option of modular placement in mind. This means that all major parts are detachable and can be placed separately (some extra wiring may be required depending on placement).

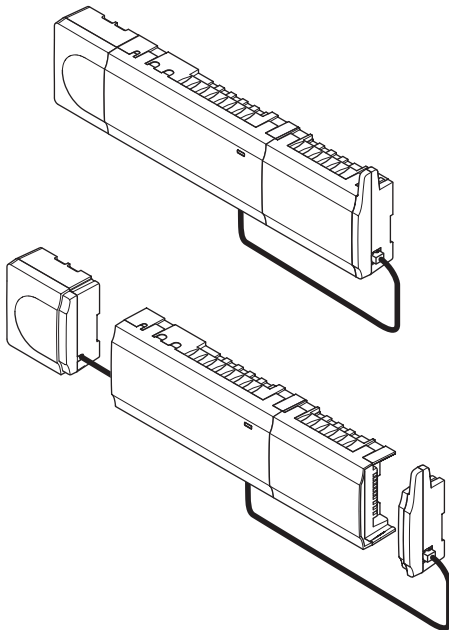

Attaching/detaching components

The components can either snap on or off without the need of removing the covers (A, recommended to do on a flat surface or on a DIN-rail), or by sliding them into place when the covers are removed (B).

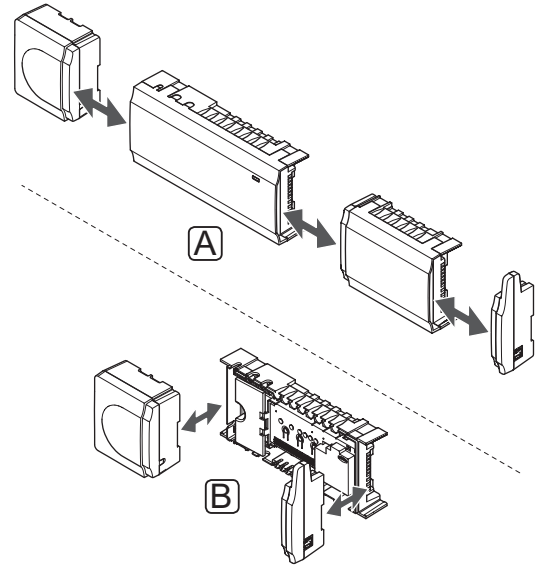

WARNING!

The transformer module is heavy and might detach if the controller is held upside down without the cover on.



CAUTION!

The slave module must be attached by snapping it into place due to connection pins sticking out of the module.



NOTE!

Wires between transformer and controller card needs to be disconnected prior to detaching the transformer.

5.2 Install controller antenna

The antenna can be attached to the right hand side of the controller or to the wall. If the controller is installed inside a metal cabinet, the entire antenna must be placed vertically outside the cabinet, as illustrated below.

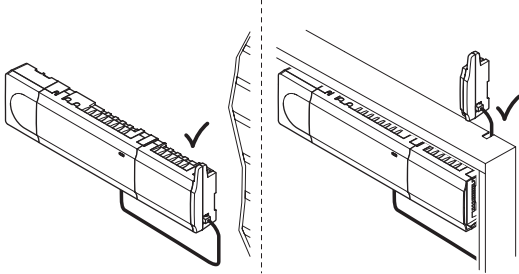

NOTE!

The antenna must be installed vertically for best coverage.

ATTACH ANTENNA TO CONTROLLER

The illustration below shows the antenna attached to the right hand side of the controller.

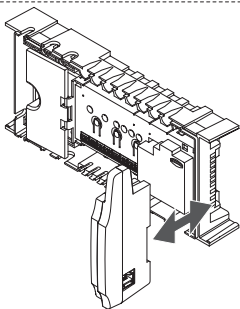
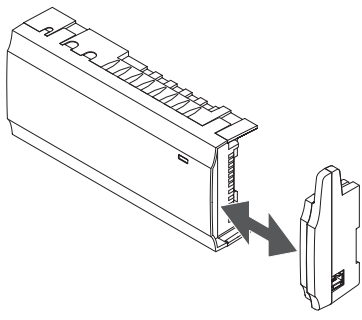

ATTACH ANTENNA TO THE WALL

The illustration below shows the antenna attached to the wall with screws (A) or double-sided adhesive strips (B).

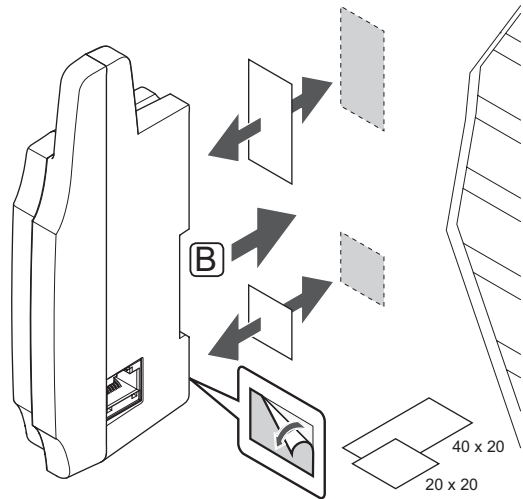
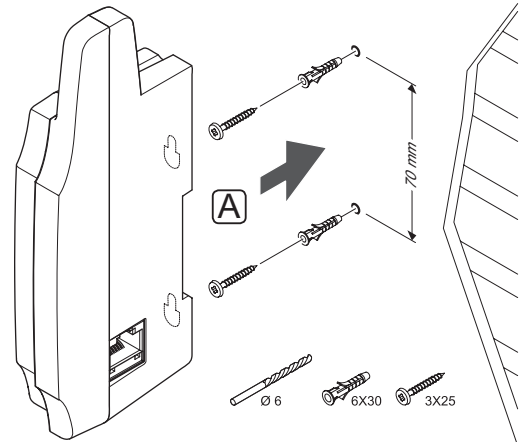

CONNECT THE ANTENNA CABLE

Connect the antenna to the controller using the supplied antenna cable.

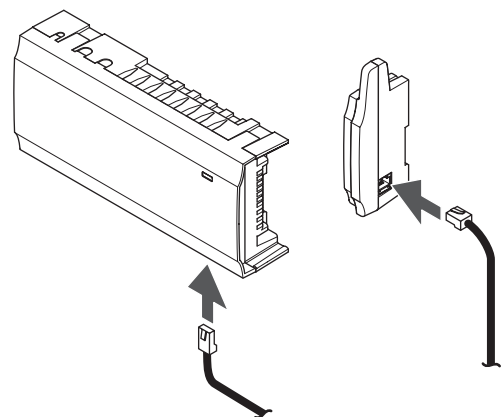

5.3 Attach controller to the wall

The controller is delivered in kits including screws, wall plugs and a DIN rail.

DIN RAIL (RECOMMENDED)

Attach the DIN rail to the wall using the screws and wall plugs. The controller is then attached to the DIN rail.

The figure below shows how to attach (A) and detach (B) the controller using a DIN rail.

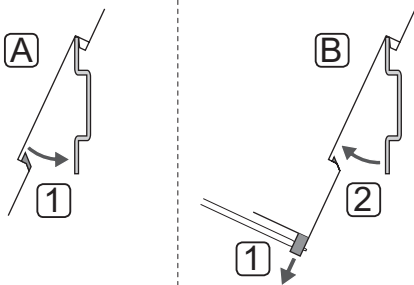
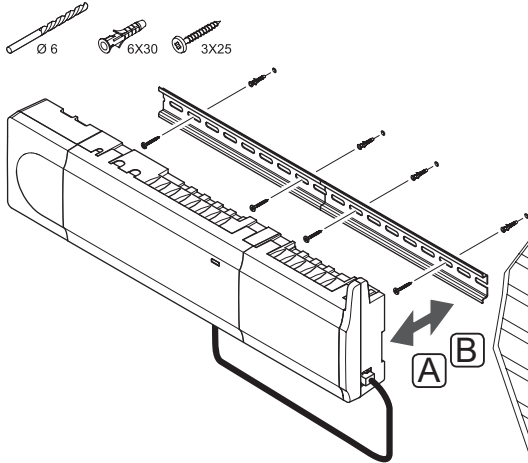

CAUTION!

Make sure the controller cannot slide off the DIN rail if mounting it in any other position than horizontal.

SCREWS AND WALL PLUGS

The figure below shows controller mounting hole positions and how to attach it to the wall using screws and wall plugs.

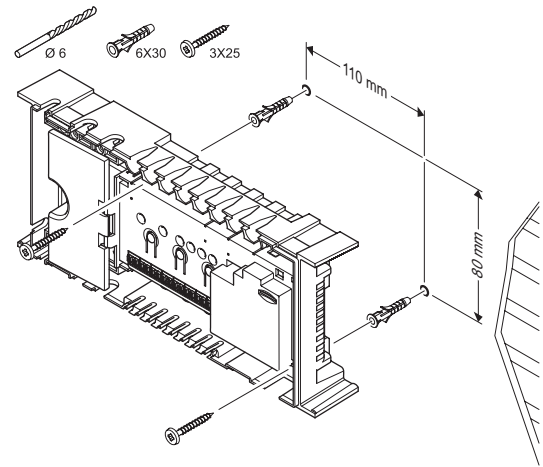

5.4 Connect the slave module (optional)

ATTACH THE SLAVE MODULE

The illustration below shows how to connect the slave module to the controller.

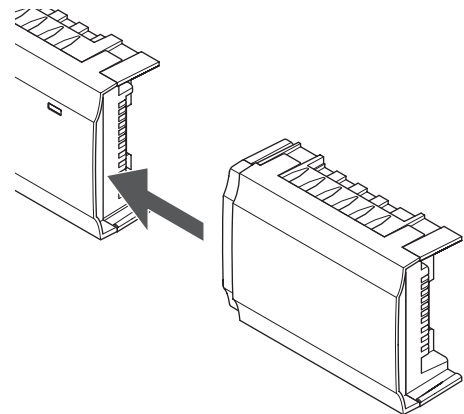

NOTE!

Only one slave module extension is supported per controller.

REMOVE THE SLAVE MODULE

The illustration below shows how to remove the slave module from the controller.

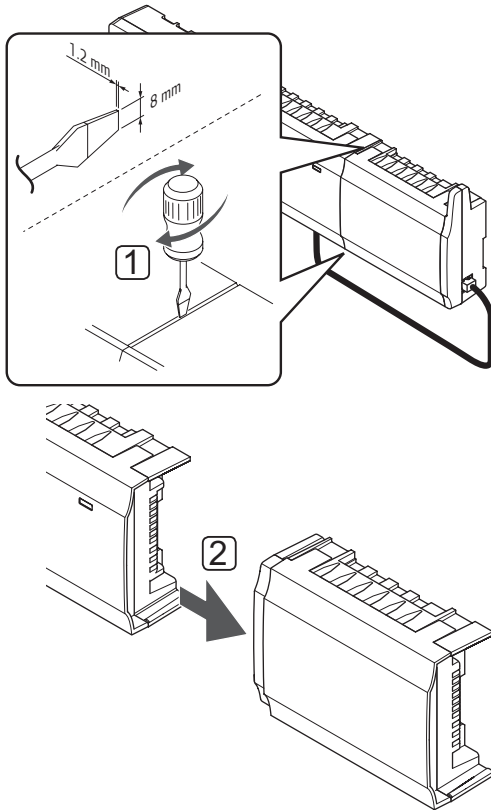

1. Place a wide flat head screwdriver in the slot between the slave module and the other unit and twist until the snap-in lock releases. Repeat for the other side.
2. Remove the slave module. Use caution not to bend the connection pins.

5.5 Connect components to controller

Refer to the wiring diagram found in the end of this document. The illustration below shows the inside of the controller.

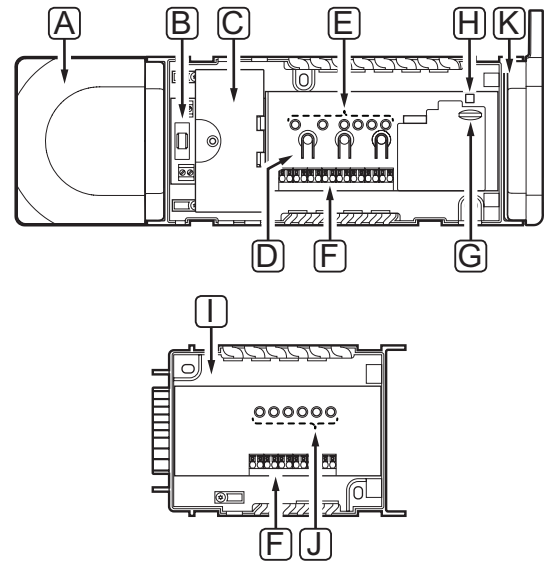

Item	Description
A	Transformer, 230 V AC 50 Hz power module
B	Fuse (T5 F3.15AL 250 V)
C	Optional inputs and outputs for pump management, boiler management, and heat pump connection
D	Channel registration buttons
E	LEDs for channels 01 – 06
F	Quick connectors for actuators
G	MicroSD card
H	Power LED
I	Uponor Smatrix Wave M-160 (optional slave module)
J	LEDs for channels 07 – 12
K	Uponor Smatrix Wave A-165 (antenna), RJ-45 connector

CONNECT ACTUATORS TO CONTROLLER

Each thermostat can control one or more channels. To simplify installation and maintenance, Uponor recommends that actuators controlled by the same thermostat shall be wired in sequence to the channels.

Connect the actuators to the controller as follows. Use the figure below for guidance to the instructions.

1. Lead the cables from the actuators through cable entries in the bottom of the controller frame. See figure below.

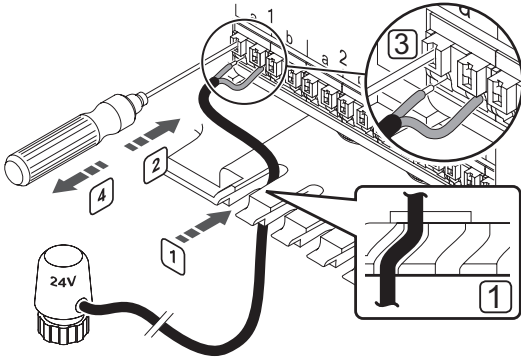

2. Press, without turning, with a thin screwdriver, on the white button of the quick connector.
3. Insert a wire in the quick connector.
4. Remove the screwdriver.



NOTE!

Identify the room supplied by each loop on the manifold and determine which channel it must be connected to.

CONNECT THERMOSTATS TO CONTROLLER

Thermostats are connected to the controller through wireless radio link.

See also section 6 Uponor Smatrix Wave thermostats and sensors for installation of thermostats.

CONNECT HEATING/COOLING INPUT TO CONTROLLER (OPTIONAL)

If the system contains a product producing cooling, the controller can switch between heating and cooling by using the heating/cooling input.

The heating/cooling input is connected to a dry contact that functions as either an auxiliary control system or two-position relay.

- When the relay is open, the system is in heating mode.
- When the relay is closed, the system is in cooling mode.

The heating/cooling switch can be connected and controlled in several different ways, depending on the system. Use only one of the following:

Uponor Smatrix Wave without interface I-167:

- Use an input:
Connect the input to either the controller, or a public thermostat registered as a system device. Switch mode using a switch on the wall or a heat pump.

Uponor Smatrix Wave with interface I-167:

- Use an input:
Connect the input to either the controller or a public thermostat. Switch mode using a switch on the wall or a heat pump.
- Use an output and the interface to switch mode:
Connect the heating/cooling relay to an output on the controller or relay module. Use the interface to set heating or cooling mode.
- Use a supply temperature sensor
Connect a supply temperature sensor to a public thermostat. Use the interface to switch between heating and cooling using the supply temperature.



CAUTION!

To avoid damaging the equipment, do not apply a voltage across the controller heating/cooling input.

For further information, see the heating/cooling relay documentation.

To connect a heating/cooling input to the controller:

The illustration below shows components of the heating/cooling system connected to a controller.

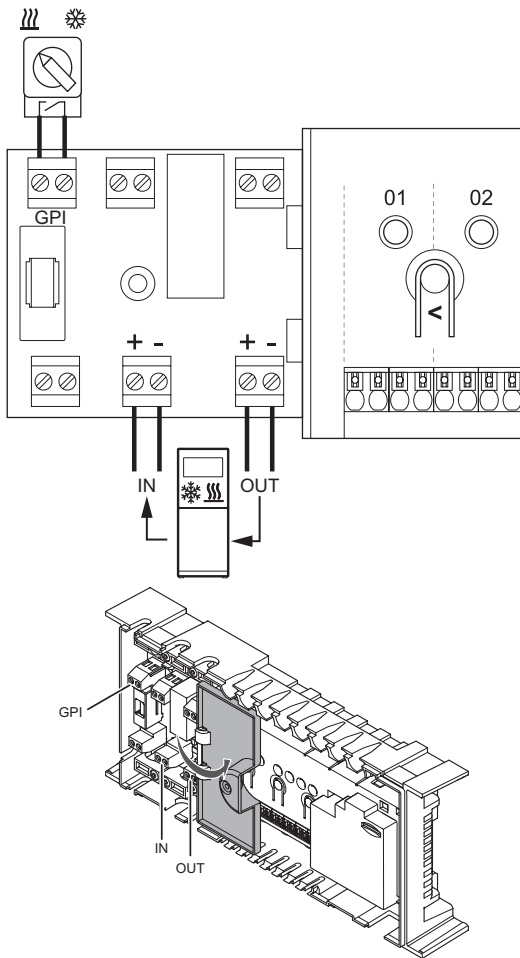

1. Study the wiring diagram in the end of the manual, or inside the cover of the controller, to locate the connector positions.
2. Ensure that the power is disconnected from both the controller and the heating/cooling relay.
3. Remove the screw and open the cover for the optional connections compartment.
4. Route the cable to/from the heating/cooling input via a cable entry.
5. Connect the cable to/from the heating/cooling input to the connection labelled **GPI** or **IN** (if a heat pump is connected) on the controller.

Wave with interface only:

6. Go to menu **Heating/cooling** in the interface and select **Cooling available**.
7. Enter the submenu **Operating mode** to the settings menu to **Heating/cooling** and select **H/C Slave**.

Heating/cooling switch is now installed and activated.



WARNING!

Electrical installation and service behind secured 230 V AC covers must be carried out under the supervision of a qualified electrician.



CAUTION!

If more than one controller is available in the system, use the input on the master controller.

To connect a heating/cooling input to a public thermostat:

The illustration below shows components of the heating/cooling system connected to a public thermostat T-163.

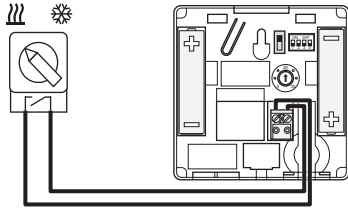

CAUTION!

If more than one controller is available in the system, register the thermostat as a system device to the master controller.



NOTE!

The external signal can be connected to up to four Wave controllers, working in parallel. This reduces the number of heating/cooling switches needed in the system.

1. Ensure that the power is disconnected from both the thermostat and the heating/cooling relay.
2. Connect the cable to/from the heating/cooling input to the input terminal on the thermostat.
3. Set the DIP switch to 1 = **Off**, 2 = **Off**, 3 = **On**, 4 = **On**. See section 6.4 *Connect external sensor to thermostat > Uponor Smatrix Wave Thermostat Public T-163* for more information.
4. Register the thermostat to the controller as a **Heating/cooling switch from contact**, system device channel **4**. See section 6.11 *Register system devices for more information*.

Wave with interface only:

5. Go to menu **Heating/cooling** in the interface and select **Cooling available**.
6. Enter the submenu **Operating mode** to the settings menu to **Heating/cooling** and select **H/C Slave**.

Heating/cooling switch is now installed and activated.

To connect a supply temperature sensor for heating/cooling switch to a public thermostat (requires interface I-167):

The illustration below shows components of the heating/cooling system connected to a public thermostat T-163.

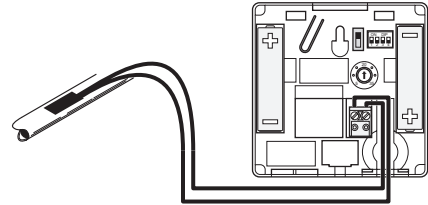

CAUTION!

If more than one controller is available in the system, register the thermostat as a system device to the master controller.

1. Ensure that the power is disconnected from the thermostat.
2. Connect the sensor attached to the supply pipe to the input terminal on the thermostat.
3. Set the DIP switch to 1 = **Off**, 2 = **Off**, 3 = **On**, 4 = **Off**. See section 6.4 *Connect external sensor to thermostat > Uponor Smatrix Wave Thermostat Public T-163* for more information.
4. Register the thermostat to the controller as a **Heating cooling switch from sensor input**, system device channel **4**. See section 6.11 *Register system devices for more information*.
5. Go to menu **Heating/cooling** in the interface and select **Cooling available**.
6. Enter the submenu **Operating mode** to the settings menu to **Heating/cooling** and select **H/C Master**.
7. Enter the settings menu to **H/C Master** in **Heating/cooling > Operating mode** and select **H/C sensor**.
8. Set a temperature and hysteresis to switch between heating and cooling.

Heating/cooling switch is now installed and activated.

To connect a heating/cooling output to a relay module:

The illustration below shows components of the heating/cooling system connected to a relay module.

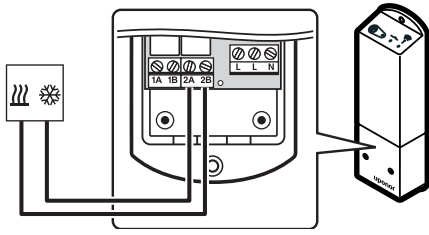

WARNING!

Electrical installation and service behind secured 230 V AC covers must be carried out under the supervision of a qualified electrician.



CAUTION!

If more than one controller is available in the system, one relay module per controller can be used. The function is set in the interface (optional).



NOTE!

This connection requires a dry contact sensing input in the component producing heating/cooling.

1. Ensure that the relay module run mode is set to Normal.
 - 1.1 Power up the relay module and count the number of flashes of LED 2 (blue).
 - 1 = Normal (default)
 - 2 = Two stage additional cooling
2. Change relay module run mode if needed.
 - 2.1 Power down the relay module and wait about 10 seconds.
 - 2.2 Press and hold the button on the relay module while turning it on again. LED 2 flashes once (Normal run mode).

3. Ensure that the power is disconnected from both the relay module and the heating/cooling relay.
4. Connect the cable to/from the component producing heating/cooling to the connector **2A** and **2B** on the relay module.
5. Register the relay module to the controller as a **Relay module**, system device channel **2**. See section 5.8 Register relay module M-161 for installation of the relay module.

Wave with interface only:

6. Go to menu **Integration** in the interface and select **Relay module**.
7. Select the controller to which the relay module is registered and select **Pump + H/C Master**.
8. Go to menu **Heating/cooling** in the interface and select **Cooling available**.
9. Enter the submenu **Operating mode** to the settings menu to **Heating/cooling** and select **H/C Master**.
10. Enter the settings menu to **H/C Master** in **Heating/cooling > Operating mode** and select **Force cooling** or **Force heating** to select either cooling or heating.
11. Verify that the relay closes, when in cooling mode, and opens, when in heating mode.

Heating/cooling output is now installed and activated.

To connect two stage additional cooling function using a relay module:

The illustration below shows components of the two stage additional cooling system connected to a relay module.

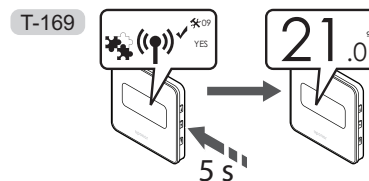
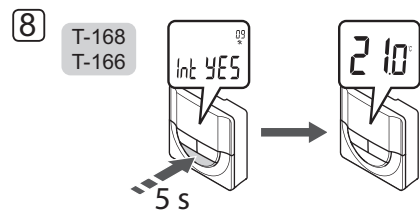
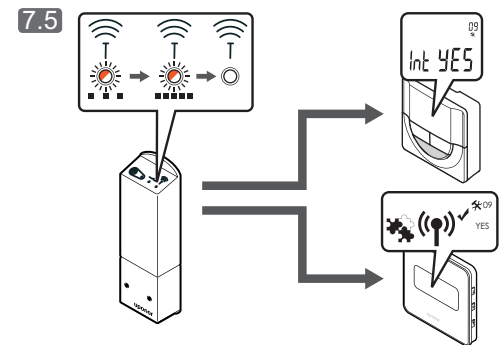
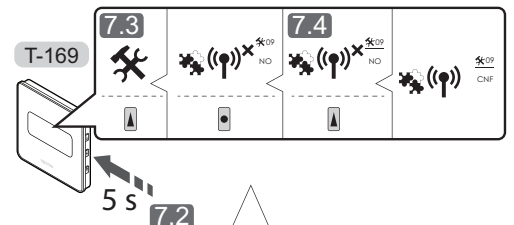
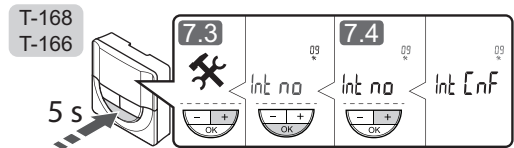
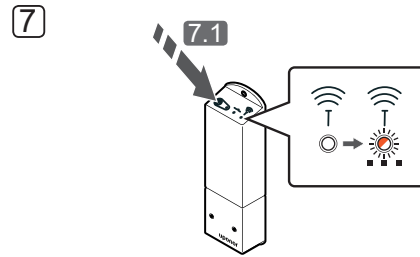
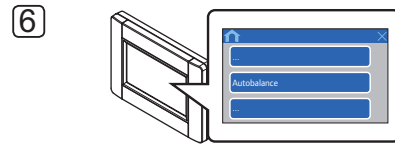
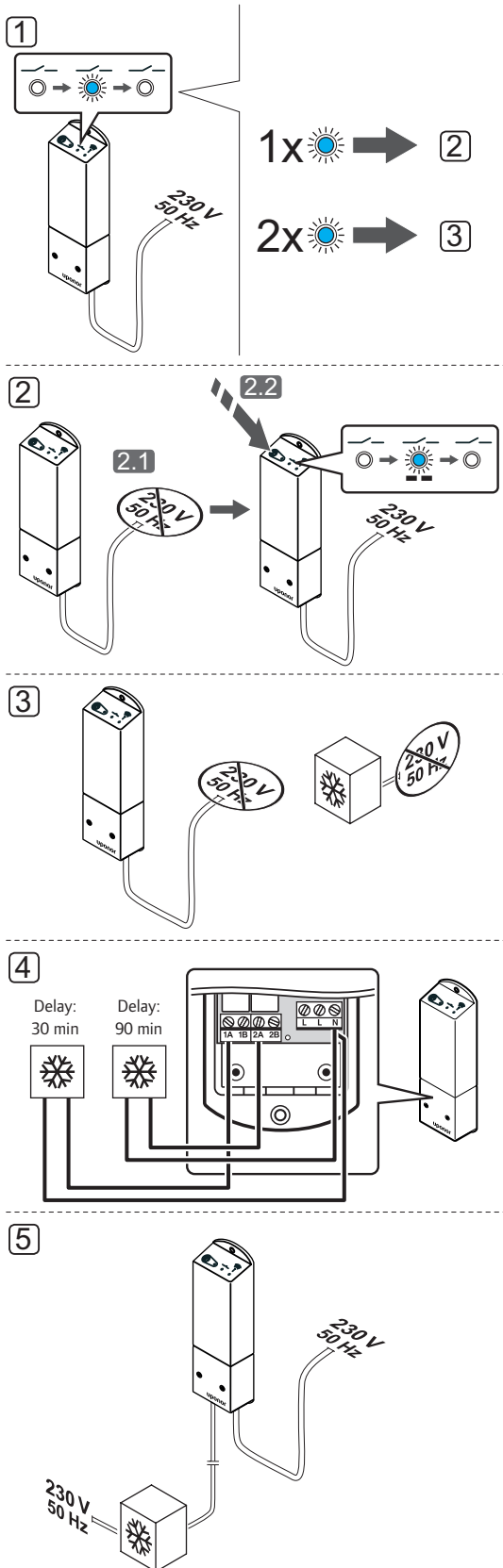

**WARNING!**

Electrical installation and service behind secured 230 V AC covers must be carried out under the supervision of a qualified electrician.

**NOTE!**

This connection requires a dry contact sensing input in the component producing heating/cooling.

1. Ensure that the relay module run mode is set to Two stage additional cooling.
 - 1.1 Power up the relay module and count the number of flashes of LED 2 (blue).
 - 1 = Normal (default)
 - 2 = Two stage additional cooling
2. Change relay module run mode if needed.
 - 2.1 Power down the relay module and wait about 10 seconds.
 - 2.2 Press and hold the button on the relay module while turning it on again. LED 2 flashes twice.
3. Ensure that the power is disconnected from the relay module and the cooling components.
4. Connect the cable to/from the component producing secondary cooling to one of the relays in the relay module.
 - Relay 1 (30 min delay): **1A** and **N**.
 - Relay 2 (90 min delay): **2A** and **N**.
5. Connect the power cables from the relay module and cooling components to a 230 V AC wall socket, or if required by local regulations, to a junction box.
6. Deactivate autobalancing in the system.

See section 14.7 System settings > Autobalance for more information.

7. Register the relay module to a thermostat (already registered to a Wave controller in the system) using settings menu 09 on the thermostat.

- 7.1 Press and hold the register button on the relay module until the LEDs on the module start flashing slowly.

THERMOSTATS T-166, T-168 AND T-169

- 7.2 Press and hold the **OK** button on the thermostat for about 5 seconds to enter the settings menu. The settings icon and menu numbers are displayed in the top right corner of the display.
- 7.3 Use buttons - or + (T-169 = ▼ or ▲) to change the numbers to **09** and press **OK**. The text **Int no** is displayed.
- 7.4 Use buttons - or + (T-169 = ▼ or ▲) to change **Int no** to **Int CNF**.
- 7.5 The connection indicator is shown in the thermostat display (starts flashing in thermostats T-166 and T-168) to show that the registration process begins. The text **Int YES** is shown in the thermostat display and the LEDs on the relay module start flashing fast again, to turn off a few seconds later.
8. Press and hold the **OK** button on the thermostat for about 5 seconds to exit the settings menu, or wait about 70 seconds for the software to exit itself.

Two stage additional cooling function is now installed and activated.

To connect a heating/cooling output to a controller (requires interface I-167):

The illustration below shows components of the heating/cooling system connected to a controller.

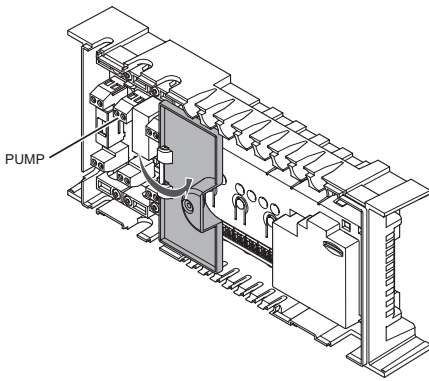
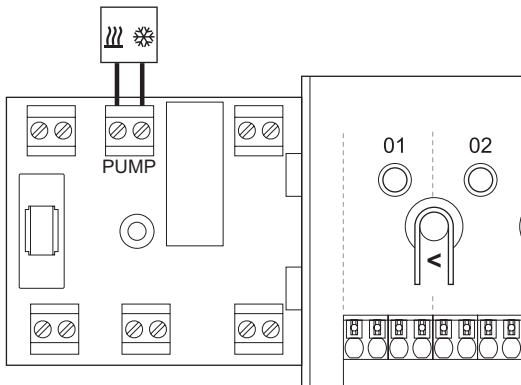

1. Ensure that the power is disconnected from both the controller and the heating/cooling relay.
2. Connect the cable to/from the component producing heating/cooling to the connector labelled **PUMP** on the controller.
4. Go to menu **Integration** in the interface and select **Controller relay**.
5. Select the controller to which the cable is connected to and set the output to **H/C switch**.
6. Go to menu **Heating/cooling** in the interface and select **Cooling available**.
7. Enter the submenu **Operating mode** to the settings menu to **Heating/cooling** and select **H/C Master**.
8. Enter the settings menu to **H/C Master** in **Heating/cooling > Operating mode** and select **Force cooling** or **Force heating** to select either cooling or heating.
9. Verify that the relay closes, when in cooling mode, and opens, when in heating mode.

Heating/cooling output is now installed and activated.



WARNING!

Electrical installation and service behind secured 230 V AC covers must be carried out under the supervision of a qualified electrician.



CAUTION!

If more than one controller (requires interface I-167) is available in the system, and the circulation pump settings in the interface is set to **Common**. The **PUMP** connector on the other controllers can be used for heating/cooling output signal.



NOTE!

This connection requires a dry contact sensing input in the component producing heating/cooling.

CONNECT PUMP MANAGEMENT (OPTIONAL)

The controller can operate a circulation pump, which stops when there is no demand for heating or cooling.



NOTE!

See the documentation from the circulation pump supplier as well as relevant Uponor wiring diagrams before connecting the pump.

- The controller cannot supply power for the pump.
- The controller uses a dry contact connection on the terminal block to control the circulation pump.
- The electrical circuits of the pump must be protected by a circuit breaker with a maximum rating of 8 A.

The circulation pump can be connected either on the controller or using a wireless relay module.

The illustration below shows how to connect a circulation pump to the controller.

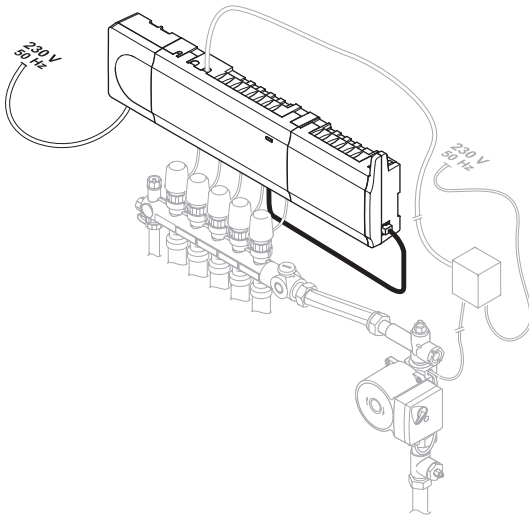

To connect a circulation pump to the controller:

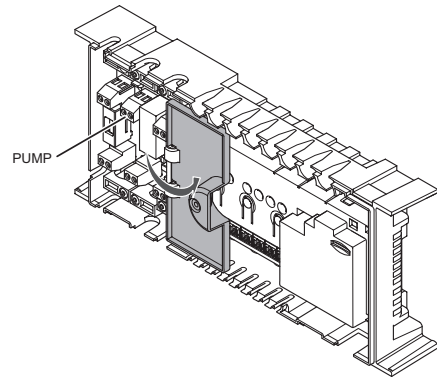
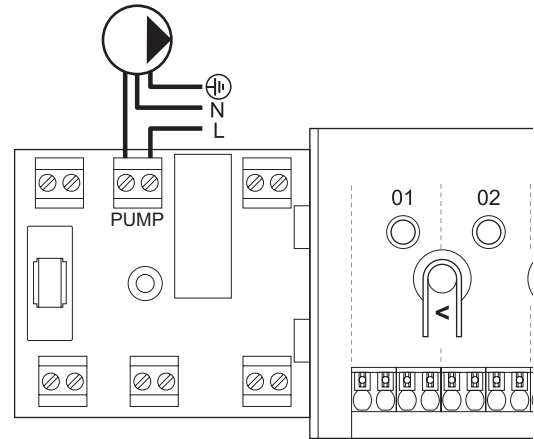

WARNING!

Electrical installation and service behind secured 230 V AC covers must be carried out under the supervision of a qualified electrician.

1. Study the wiring diagram in the end of the manual, or inside the cover of the controller, to locate the connector positions.
2. Ensure that the power is disconnected from both the controller and the circulation pump.
3. Remove the screw and open the cover for the optional connections compartment.
4. Route the cable to/from the pump via a cable entry.
5. Connect the L wire to/from the pump via the connection labelled **PUMP**.



NOTE!

There is no power in the controller to supply the pump. The pump connector in the controller provides only a dry contact to switch off and on the power connection to the pump.

6. Secure the pump cable with a cable clamp in the enclosure.
7. Close and secure the lid to the optional connections compartment.

To connect a circulation pump to a relay module:

The illustration below shows a circulation pump connected to a relay module.

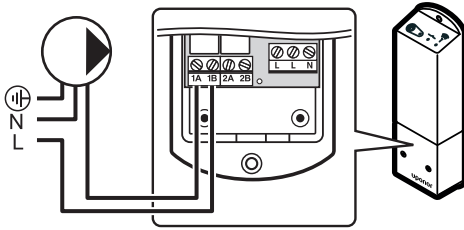

WARNING!

Electrical installation and service behind secured 230 V AC covers must be carried out under the supervision of a qualified electrician.

1. Ensure that the relay module run mode is set to Normal.
 - 1.1 Power up the relay module and count the number of flashes of LED 2 (blue).
 - 1 = Normal (default)
 - 2 = Two stage additional cooling
2. Change relay module run mode if needed.
 - 2.1 Power down the relay module and wait about 10 seconds.
 - 2.2 Press and hold the button on the relay module while turning it on again. LED 2 flashes once (Normal run mode).

3. Ensure that the power is disconnected from both the relay module and the circulation pump.
4. Connect the L wire to/from the pump via the connection labelled **1A** and **1B**.



NOTE!

There is no power in the relay module to supply the pump. The pump connector in the relay module provides only a dry contact to switch off and on the power connection to the pump.

5. Register the relay module to the controller as a **Relay module**, system device channel **2**. See section 5.8 Register relay module M-161 for installation of the relay module.

Wave with interface only:

6. Go to menu **Integration** in the interface and select **Relay module**.
7. Select the controller to which the relay module is registered and select **Pump + H/C Master** or **Pump + Dehumidifier**, depending on the use of the other relay.

A circulation pump is now connected to a relay module and activated.

Shared or individual pumps

A pump for all manifolds and controllers can be connected to the closest controller.

If separate pumps are used for each manifold, each pump can be connected to be run by its own controller, as shown in the illustration below.

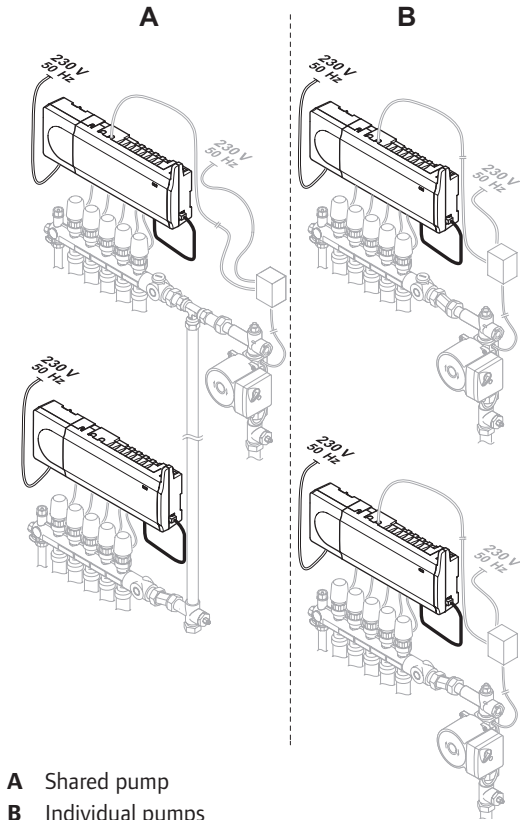

A Shared pump
B Individual pumps

CONNECT BOILER (OPTIONAL)

The controller includes a boiler relay, it can be used to send a signal to either fire the heat source or to power open a 2-port motorised zone valve positioned on the flow to the underfloor heating manifold. If the relay is used to power open a zone valve then, the volt free auxiliary contacts on the zone valve should be used to fire the heat source.

Alternatively, the boiler relay can be used to send a demand signal to an electrically operated water temperature controller. The additional contacts on the water temperature controller should then be used to fire the heat source.

The boiler can be connected either on the controller or, in a Wave system with an interface I-167, using a wireless relay module.

To connect a boiler to the controller:

The illustration below shows how to connect a boiler to the controller.

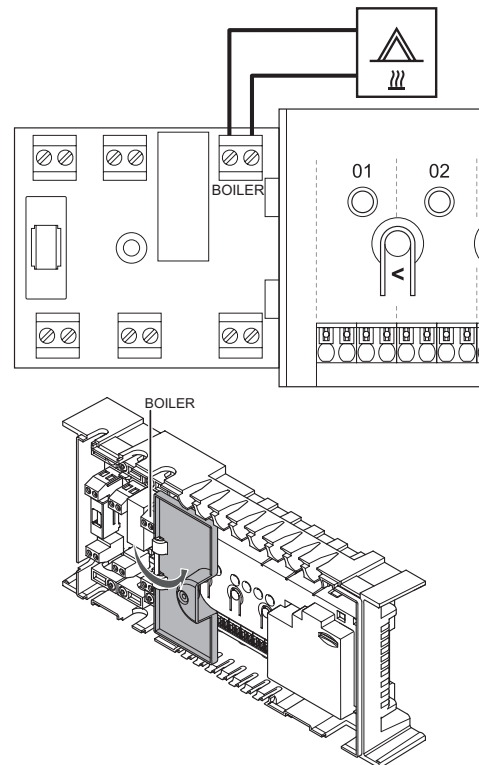

**WARNING!**

Electrical installation and service behind secured 230 V AC covers must be carried out under the supervision of a qualified electrician.

**NOTE!**

This connection requires a dry contact sensing input in the boiler.

1. Study the wiring diagram in the end of the manual, or inside the cover of the controller, to locate the connector positions.
2. Ensure that the power is disconnected from both the controller and the boiler.
3. Remove the screw and open the cover for the optional connections compartment.
4. Route the cable from/to the boiler via a cable entry.
5. Connect the boiler to the connection labelled **BOILER**.

**NOTE!**

There is no power in the controller to supply the boiler. The boiler connector in the controller provides only a dry contact to switch on and off the power connection to the boiler.

6. Secure the cable to/from the boiler with a cable clamp in the enclosure.
7. Close and secure the lid to the optional connections compartment.

To connect a boiler to a relay module (requires interface I-167):

The illustration below shows a boiler connected to a relay module.

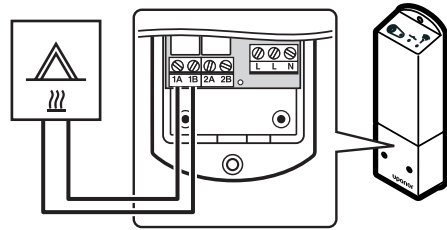
**WARNING!**

Electrical installation and service behind secured 230 V AC covers must be carried out under the supervision of a qualified electrician.

**NOTE!**

This connection requires a dry contact sensing input in the boiler.

1. Ensure that the relay module run mode is set to Normal.
 - 1.1 Power up the relay module and count the number of flashes of LED 2 (blue).
1 = Normal (default)
2 = Two stage additional cooling
2. Change relay module run mode if needed.
 - 2.1 Power down the relay module and wait about 10 seconds.
 - 2.2 Press and hold the button on the relay module while turning it on again.
LED 2 flashes once (Normal run mode).
3. Ensure that the power is disconnected from both the relay module and the boiler.
4. Connect the cable to/from the boiler to the connector **1A** and **1B** on the relay module.
5. Register the relay module to the controller as a **Relay module**, system device channel **2**. See section 5.8 Register relay module M-161 for installation of the relay module.
6. Go to menu **Integration** in the interface and select **Relay module**.
7. Select the controller to which the relay module is registered and select **Boiler + Chiller**.

A boiler is now connected to a relay module and activated.

CONNECT HEAT PUMP INTEGRATION (OPTIONAL, REQUIRES INTERFACE I-167)

The controller can connect to selected heat pumps and adjust the supply temperature to the system.

The illustration below shows how to connect a compatible heat pump to the controller.

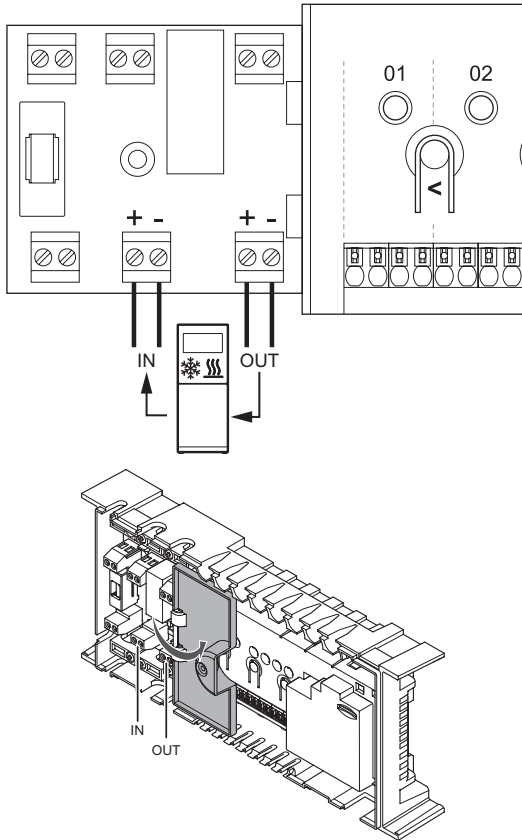

Contact a local Uponor office for complete list of compatible heat pumps.

To connect a compatible heat pump to the controller:

1. Study the wiring diagram in the end of the manual, or inside the cover of the controller, to locate the connector positions.
2. Ensure that the power is disconnected from both the controller and the heat pump.
3. Remove the screw and open the cover for the optional connections compartment.
4. Route the cables from/to the heat pump via a cable entry.
5. Connect the signal cable receiving from the heat pump to the connection labelled **IN**.
6. Connect the signal cable sending to the heat pump to the connection labelled **OUT**.
7. Secure the cables to/from the heat pump with cable clamps in the enclosure.
8. Close and secure the lid to the optional connections compartment.
9. Activate heat pump integration in the interface I-167.



WARNING!

Electrical installation and service behind secured 230 V AC covers must be carried out under the supervision of a qualified electrician.



CAUTION!

If **Heat pump integration** is deactivated in the interface (optional) make sure that it also is deactivated in the heat pump. Otherwise it may affect the operation of the heat pump.



NOTE!

See the heat pump supplier documentation and the relevant Uponor wiring diagram before performing the connection.

CONNECT DEHUMIDIFIER (REQUIRES INTERFACE I-167)

The system can control up to four dehumidifiers, one per controller, connected through a relay module. The dehumidifier starts when the relative humidity setpoint is reached when in cooling mode. It will stop when the minimum run time of 30 minutes has finalized and when the relative humidity has decreased below the defined RH setpoint - deadzone.



NOTE!

See the dehumidifier supplier documentation and the relevant Uponor wiring diagram before performing the connection.

The controller uses an output on the Uponor Smatrix Relay Module M-161 for this purpose. Only one dehumidifier can be controlled per controller. This output is a dry contact relay output.

To connect a dehumidifier to a relay module:

The illustration below shows a dehumidifier connected to a relay module.

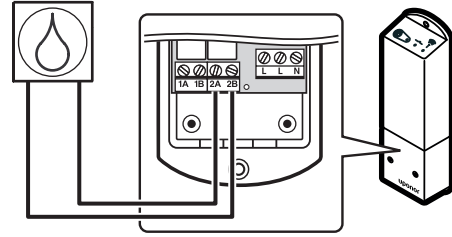

WARNING!

Electrical installation and service behind secured 230 V AC covers must be carried out under the supervision of a qualified electrician.



NOTE!

This connection requires a dry contact sensing input in the dehumidifier.

1. Ensure that the relay module run mode is set to Normal.
 - 1.1 Power up the relay module and count the number of flashes of LED 2 (blue).
 - 1 = Normal (default)
 - 2 = Two stage additional cooling
2. Change relay module run mode if needed.
 - 2.1 Power down the relay module and wait about 10 seconds.
 - 2.2 Press and hold the button on the relay module while turning it on again.
 - LED 2 flashes once (Normal run mode).
3. Ensure that the power is disconnected from both the relay module and the dehumidifier.
4. Connect the cable to/from the dehumidifier to the connector **2A** and **2B** on the relay module.
5. Register the relay module to the controller as a **Relay module**, system device channel **2**. See section 5.8 Register relay module M-161 for installation of the relay module.
6. Go to menu **Integration** in the interface and select **Relay module**.
7. Select the controller to which the relay module is registered and select **Pump + Dehumidifier**.

A dehumidifier is now connected to a relay module and activated.

CONNECT CHILLER (REQUIRES INTERFACE I-167)

The system can control up to four chillers, one per relay module. The chiller starts when there is a cooling demand while in cooling mode. It will stop when the cooling demand is met.



NOTE!

See the chiller supplier documentation and the relevant Uponor wiring diagram before performing the connection.

The controller uses an output on the Uponor Smatrix Relay Module M-161 for this purpose. Only one chiller can be controlled per controller. This output is a dry contact relay output.



WARNING!

Electrical installation and service behind secured 230 V AC covers must be carried out under the supervision of a qualified electrician.

To connect a chiller to a relay module:

The illustration below shows a chiller connected to a relay module.

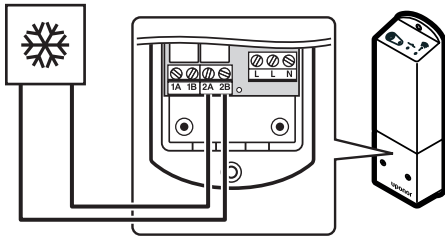

WARNING!

Electrical installation and service behind secured 230 V AC covers must be carried out under the supervision of a qualified electrician.



NOTE!

This connection requires a dry contact sensing input in the chiller.

1. Ensure that the relay module run mode is set to Normal.
 - 1.1 Power up the relay module and count the number of flashes of LED 2 (blue).
 - 1 = Normal (default)
 - 2 = Two stage additional cooling
2. Change relay module run mode if needed.
 - 2.1 Power down the relay module and wait about 10 seconds.
 - 2.2 Press and hold the button on the relay module while turning it on again.
 - LED 2 flashes once (Normal run mode).
3. Ensure that the power is disconnected from both the relay module and the chiller.
4. Connect the cable to/from the chiller to the connector **2A** and **2B** on the relay module.
5. Register the relay module to the controller as a **Relay module**, system device channel **2**. See section 5.8 Register relay module M-161 for installation of the relay module.
6. Go to menu **Integration** in the interface and select **Relay module**.
7. Select the controller to which the relay module is registered and select **Boiler + Chiller**.

A chiller is now connected to a relay module and activated.

5.6 Connect the controller to AC power

To conclude the installation of the controller:

1. Check that all wiring is complete and correct:
 - Actuators
 - Heating/cooling switch
 - Circulation pump
2. Ensure that the 230 V AC compartment of the controller is closed and the fixing screw is tightened.
3. Connect the power cable to a 230 V AC wall socket, or if required by local regulations, to a junction box.

5.7 Test actuators

It is possible to manually open or close an actuator connected to a channel when testing the system. Testing an actuator takes about 10 minutes and the controller automatically returns to run mode when finished.

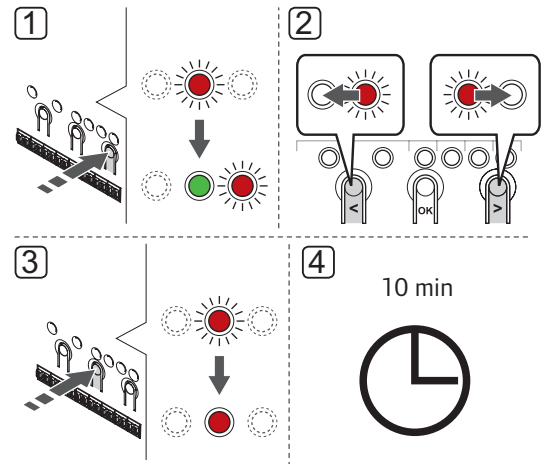

NOTE!

Activated forced mode for a channel is indicated with a lit LED, when in forced mode.

To test the actuators:

1. Enter forced mode by pressing the > button while in run mode.
For information about how to exit to run mode, see section 10.4 Run mode > Exit to run mode.
2. Use the < or > buttons to select a channel. Selected channel is indicated with a LED flashing red.
3. Press the **OK** button to activate forced mode for the selected channel. The LED of the channel turns fixed red, which means that the controller opens the actuator on the selected channel, and the system exits to run mode. If the LED keeps flashing, the channel cannot be chosen for forced operation.

If the LED does not turn fixed red it might be the actuator management delaying the actuator if more than eight channels is opened at the same time. Otherwise refer to the troubleshooting section.
4. Wait for 10 minutes, or enter forced mode again, choose the activated channel and press the **OK** button for the system to end the test.

A forced operation can always be cancelled by entering forced mode, selecting the active channel, and pressing the **OK** button.

5.8 Register relay module M-161

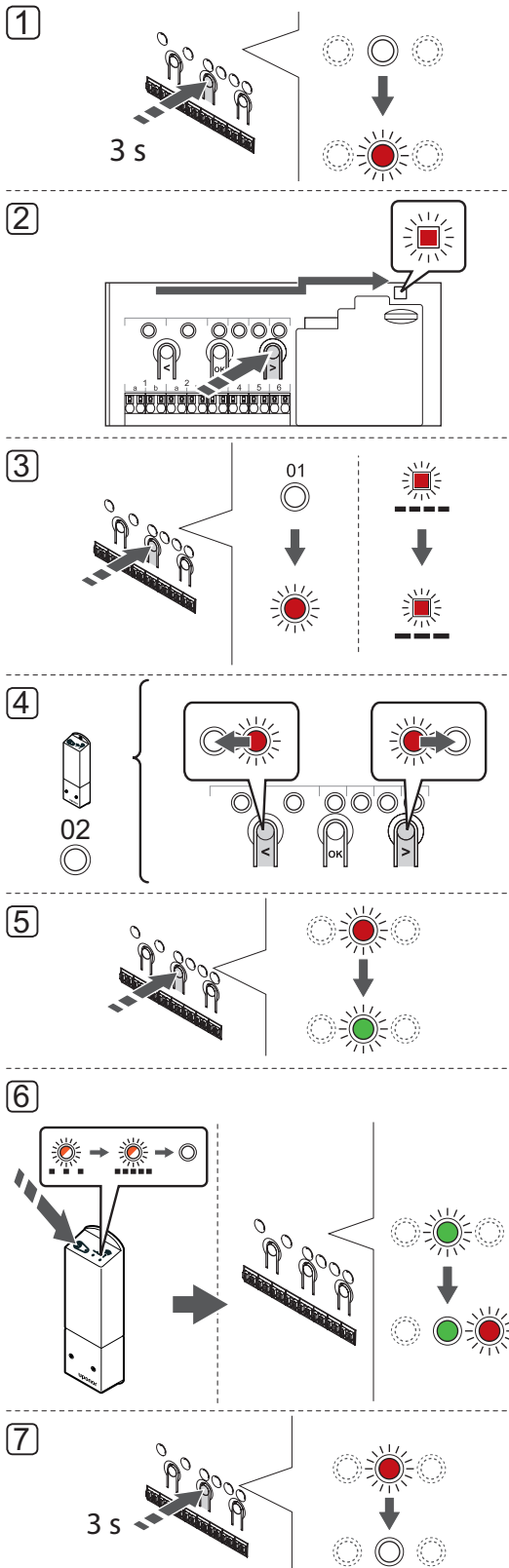

NOTE! Registration of at least one thermostat must be done before registering a system device.

NOTE! Make sure all components are connected to the relay module before registering.

CAUTION! Make sure the controller is in run mode. For information about how to exit to run mode, see section 10.4 Run mode > Exit to run mode.







To register the relay module to a controller:

1. Press and hold the **OK** button on the controller until one of the channel LEDs starts flashing.
2. Use buttons < or > to move the pointer to the power LED (LED flashes red).
3. Press the **OK** button to enter system device registration mode (power LED). The power LED starts flashing according to the pattern long blink, short pause, long blink. Channel 1 starts flashing red.
4. Press the > button to move the pointer (LED flashes red) to channel 2.
5. Press the **OK** button to select system device channel 2 (relay module). Channel 2 LED starts flashing green.
6. Press and hold the register button on the relay module until the LEDs on the module start flashing slowly. The selected channel LED in the controller turns fixed green and the LEDs on the relay module start flashing fast again, to turn off a few seconds later.
7. Press and hold the **OK** button until the green LEDs turn off to end registration and return to run mode.

To unregister an already registered relay module, see section 10.6 Unregister channels in controller.

6 Install Uponor Smatrix Wave thermostats and sensors

The following thermostats can be connected to the system:

	Uponor Smatrix Wave T-169 (digital thermostat with RH T-169)
	Uponor Smatrix Wave T-168 (programmable thermostat with RH T-168)
	Uponor Smatrix Wave T-166 (digital thermostat T-166)
	Uponor Smatrix Wave T-165 (standard thermostat T-165)
	Uponor Smatrix Wave T-163 (public thermostat T-163)
	Uponor Smatrix Wave T-161 (sensor thermostat T-161)

6.1 Placement of thermostats

Refer to the installation preparation guidelines (see section 4.2 *Prepare for installation*), and use the following guidelines when positioning the thermostats:

1. Select an indoor wall and a position 1.3 m to 1.5 m above the floor.
2. Ensure that the thermostat is away from direct solar radiation.
3. Ensure that the thermostat will not be heated through the wall by sunshine.
4. Ensure that the thermostat is away from any source of heat, for example television set, electronic equipment, fireplace, spotlights, and so on.
5. Ensure that the thermostat is away from any source of humidity and water splashes (IP20).
6. Ensure that the thermostat is positioned at least 40 cm away from the controller to avoid interference.

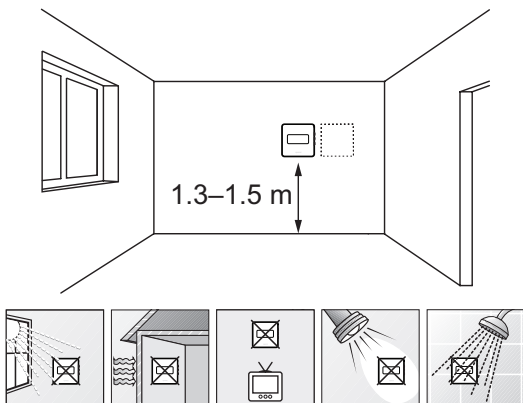

6.2 Label thermostats

Label the thermostats, where suitable, with the channel numbers they are to control, for example, #02, #03.

For a system with interface and several controllers, add the ID of each controller, for example, 1.02, 1.03, 2.02, 2.03.

If the thermostat can connect to an external sensor, add information about sensor type when applicable.

Available thermostat and sensor combinations:

- Room temperature
- Room and floor temperature
- Room and outdoor temperature
- Remote sensor temperature

6.3 Insert batteries

THERMOSTATS T-161 AND T-169

The thermostats use a single CR2032 3V button cell lithium battery which provides about 2 years of battery life, as long as they are positioned within radio range of the controller. Ensure that the battery is correctly inserted in the thermostat.

The thermostat will perform a self test, for about 10 seconds, when the battery have been inserted. The system will be blocked for input and the thermostat LED flashes (T-161 only) during this period.

The illustration below shows how to remove the plastic transportation strip from the battery, starting the thermostat.

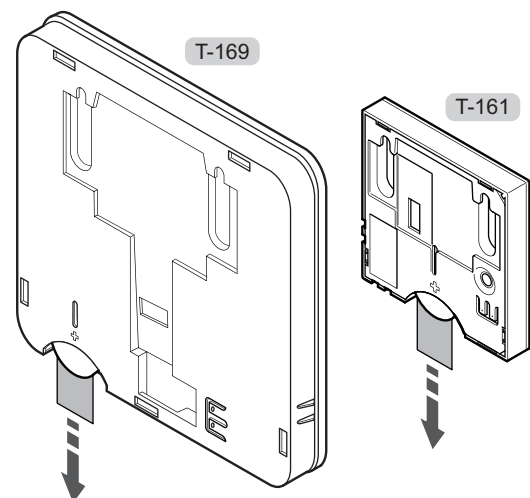

THERMOSTATS T-163, T-165, T-166, AND T-168

The thermostats use two alkaline 1.5 V AAA batteries which provides about 2 years of battery life, as long as they are positioned within radio range of the controller. Ensure that the batteries are correctly inserted in the thermostat.

The thermostat will perform a self test, for about 10 seconds, when the batteries have been inserted. The system will be blocked for input and the thermostat LED flashes during this period.

The illustration below shows how to remove the plastic transportation strip from the batteries, starting the thermostat.

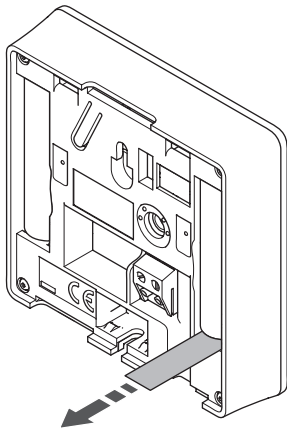

6.4 Connect external sensor to thermostat (optional)

An optional external sensor can be connected to the thermostats (except the standard thermostat T-165) for extra functionality.

! NOTE!

For accurate temperature: attach the outdoor sensor to the north side of the building where it is unlikely to be exposed to direct sunlight. Do not place it close to doors, windows, or air outlets.

THERMOSTATS T-161 AND T-169

Connect the sensor to the terminal located at the back of the thermostat, as shown in the illustration below.

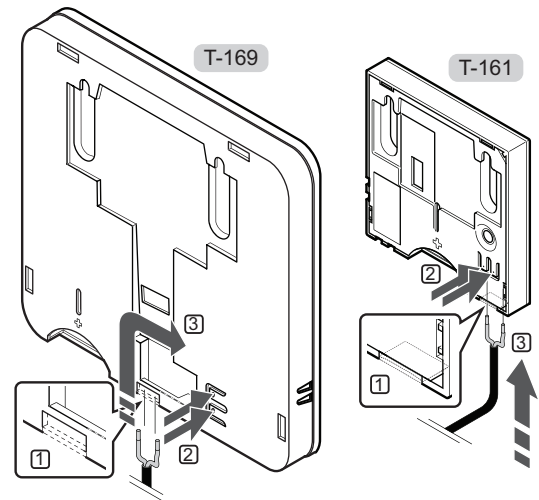

1. Remove the breakout plastic.
2. Press the push buttons on the connection terminals on the back of the thermostat.
3. While pressing the push buttons, insert the two wires from the sensor cable (non polarized) into the connection terminal.

THERMOSTATS T-163, T-166, AND T-168

Connect the sensor to the terminal located at the back of the thermostat, as shown in the illustration below.

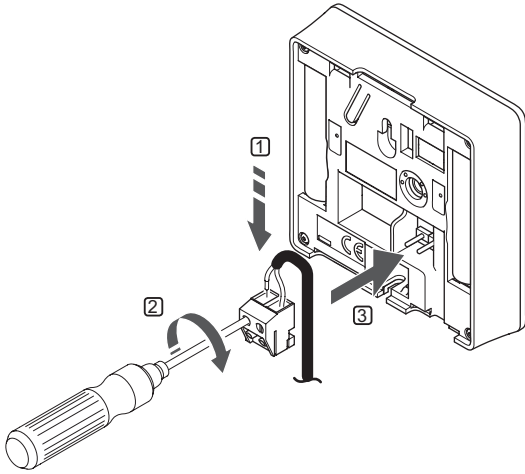

1. Insert the two wires from the sensor cable (non polarized) into the removable connector.
2. Tighten the screws fixing the wires in the connector.
3. Insert the connector on the input pegs on the thermostat.

6.5 Sensor input function

THERMOSTAT T-169

The external temperature sensor input can be used for either a floor, outdoor or remote temperature sensor. Use the software on the thermostat to select a control mode which corresponds to the use of the sensor and thermostat.

See section 13 Operate Uponor Smatrix Wave digital thermostats for more information.

THERMOSTAT T-168

The external temperature sensor input can be used for either a floor, outdoor or remote temperature sensor. Use the software on the thermostat to select a control mode which corresponds to the use of the sensor and thermostat.

See section 13 Operate Uponor Smatrix Wave digital thermostats for more information.

THERMOSTAT T-166

The external temperature sensor input can be used for either a floor, outdoor or remote temperature sensor. Use the software on the thermostat to select a control mode which corresponds to the use of the sensor and thermostat.

See section 13 Operate Uponor Smatrix Wave digital thermostats for more information.

THERMOSTAT T-163

The external temperature sensor input can be used for either a floor temperature sensor, an outdoor temperature sensor, a supply temperature sensor for heating/cooling switch (Wave with interface only), a heating cooling switch, or a Comfort/ECO switch. Use the DIP switches on the thermostat to select a control mode which corresponds to the use of the sensor and thermostat.



CAUTION!

If more than one controller is available in the system, register the thermostat as a system device to the master controller.



NOTE!

The external signal can be connected to up to four Wave controllers, working in parallel. This reduces the number of heating/cooling switches needed in the system.

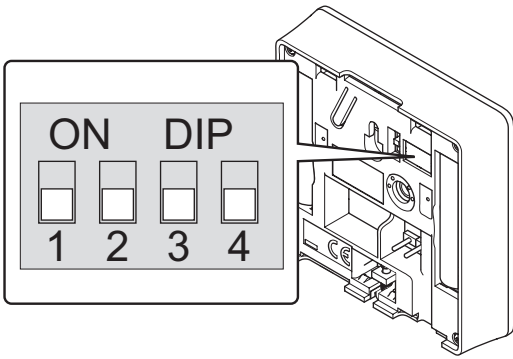

Function*	Switch
Standard room thermostat	
Standard room thermostat together with a floor temperature sensor	
Standard room thermostat, or system device, together with an outdoor temperature sensor	
System device together with a supply temperature sensor for heating/cooling switch over function **	
System device where the sensor input is used for Comfort/ECO switch over function ***	
Remote sensor	
System device where the sensor input is used for heating/cooling switch-over function ****	

* If registering the thermostat as a system device, it will no longer work as a standard room thermostat any more.

** Wave with interface only

*** Closed = ECO

**** Closed = Cooling



CAUTION!

The switches must be set before the thermostat is registered.



CAUTION!

The switches must be set to one of the available functions, otherwise the thermostat cannot be registered.

THERMOSTAT T-161

The external temperature sensor input can be used to connect a floor temperature sensor. Thermostat control mode for the T-161 is set when a floor sensor is connected to the thermostat.



CAUTION!

If more than one hour has passed between startup of the thermostat, and the sensor being inserted. Remove the battery from the thermostat, wait 30 seconds and reinsert the battery again. The thermostat will now be configured with a floor sensor.

6.6 Attach a thermostat to the wall

The thermostats are delivered in kits including screws, wall plugs, and a wall bracket, presenting several options of attaching the thermostat to the wall.

T-169
T-161

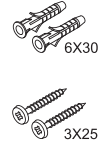
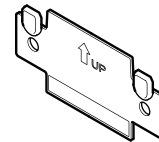

T-168
T-166
T-165
T-163

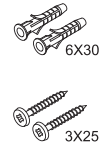
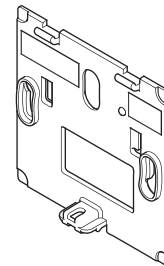

USING WALL BRACKET (RECOMMENDED)

The illustration below shows thermostat mounting hole positions and how to attach it to the wall using a wall bracket.

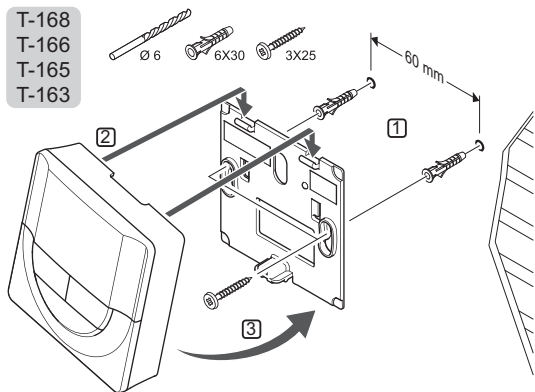
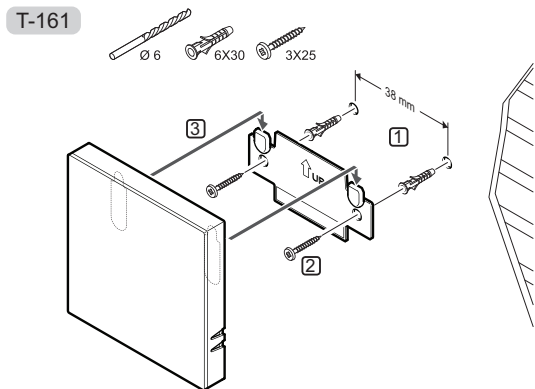
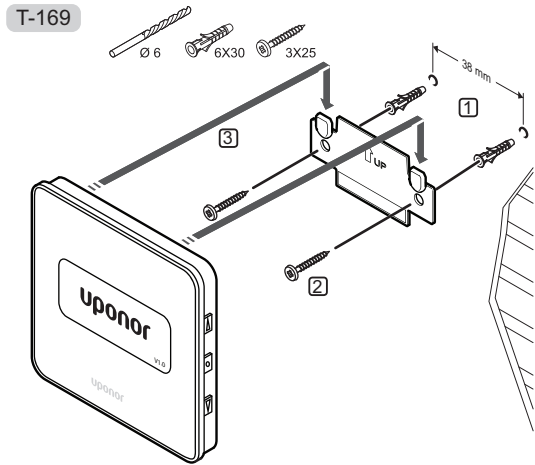

SCREW AND WALL PLUG

The illustration below shows how to attach the thermostat to the wall using screws and wall plugs.

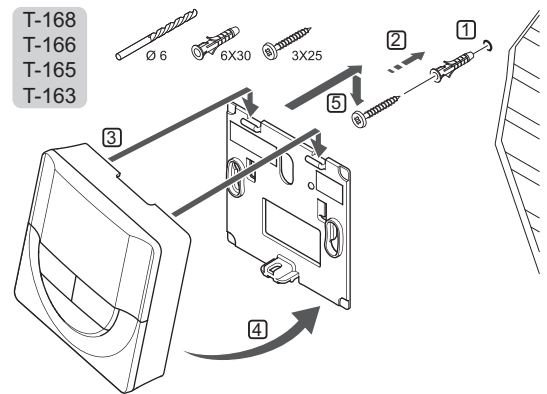
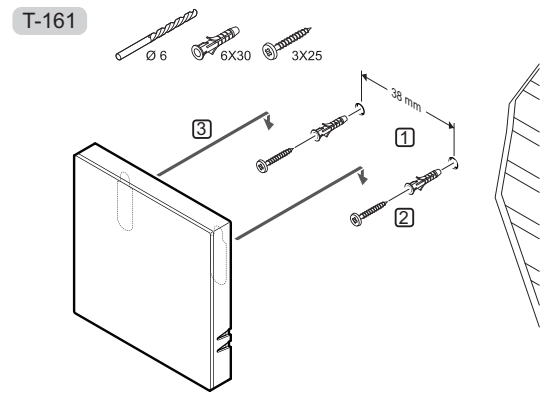
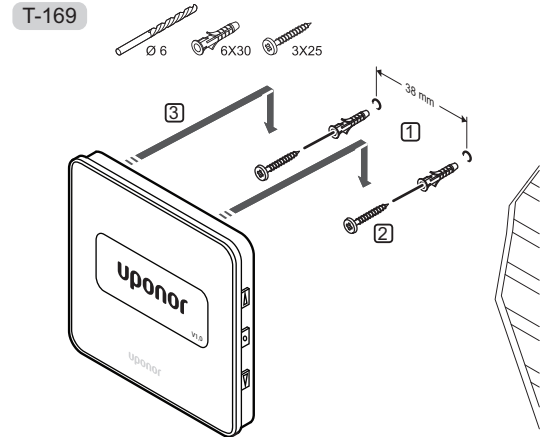

USING ADHESIVE STRIP

The illustration below shows how to attach the thermostat to the wall using an adhesive strip and a wall bracket.

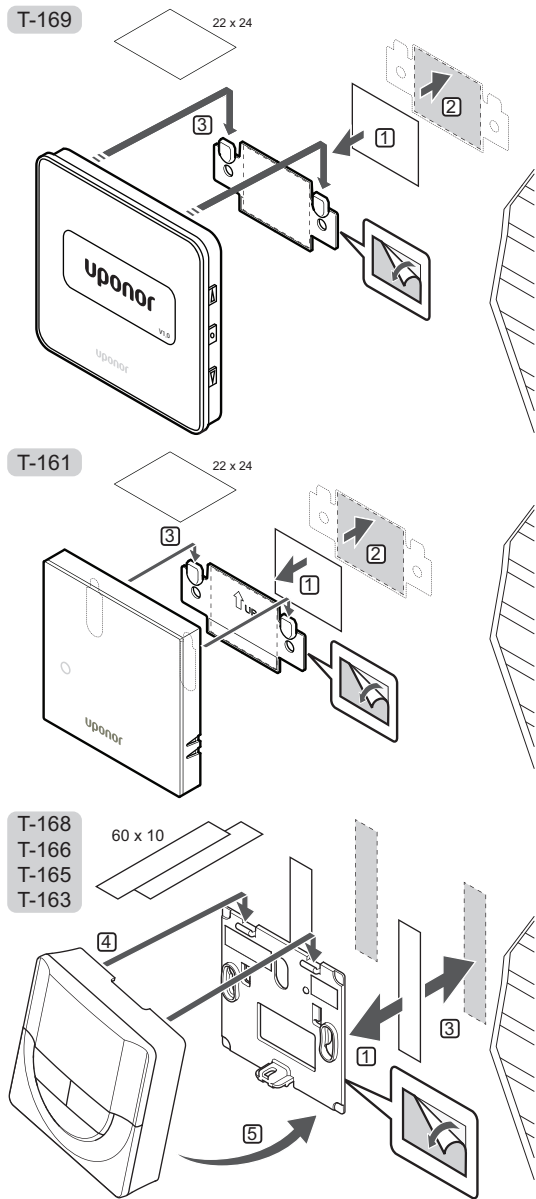

6.7 Attach to table stand (T-163, T-165, T-166, and T-168 only)

The illustration below shows how to attach the thermostat to a table stand.

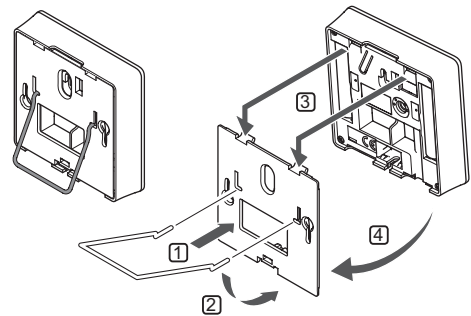

6.8 First startup of digital thermostats

At first startup, before registering, the thermostat requires some basic settings.

See section 13 Operate Uponor Smatrix Wave digital thermostats for more information.

SOFTWARE VERSION

Current software version is displayed during power up.

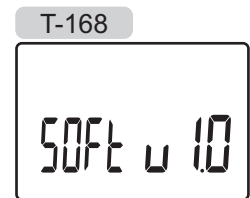
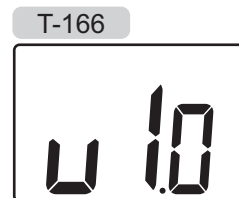

SET TIME (T-168 ONLY)

When starting the thermostat for the first time, after a factory reset, or after its been left without batteries too long, the software requires the time and date to be set. This setting is required to utilise scheduling programs for this thermostat.

Use buttons - or + to change the value, press the **OK** button to set the value and move to the next editable value.

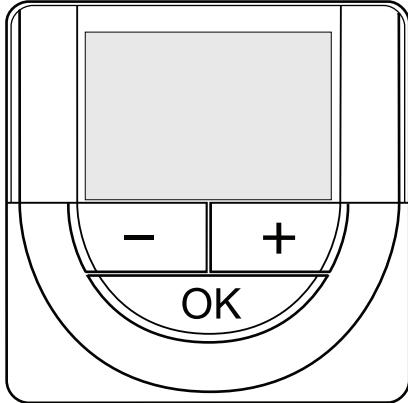
**NOTE!**

If no button is pressed for about 8 seconds, the current values will be saved and the software exits to control mode.

1. Set hours.



2. Set minutes.



3. Set 12h or 24h display of time.



4. Set day of the week (1 = Monday, 7 = Sunday).



5. Set day of the month.



6. Set month.



7. Set year.



8. Press **OK** to return to run mode.

Date and time can also be set in the settings menu.

6.9 First setup of digital thermostats

SELECT THERMOSTAT CONTROL MODE

If an external sensor is connected to the thermostat, a control mode must be selected to accommodate the extra functionality of the sensor.



NOTE!

If no button is pressed for about 8 seconds, while in a submenu, the current values will be saved and the software exits to the settings menu. About about 60 seconds later, it exits to run mode.

1. Press and hold the **OK** button until the settings icon and menu numbers is displayed in the top right corner of the display (about 3 seconds).
2. Use buttons - or + (T-169 = ▼ or ▲) to change the numbers to **04** and press **OK**.
3. Current control mode is displayed (RT, RFT, RS or RO).
4. Use buttons - or + (T-169 = ▼ or ▲) to change control mode (see list below) and press **OK**.

T-169	T-166/ T-168	Description
	RT	Room temperature
	RFT	Room temperature with external floor sensor
	RS	Remote sensor
	RO	Room temperature with remote outdoor sensor

5. Press and hold the **OK** button for about 3 seconds to exit the settings menu.

TEMPERATURE SETPOINT

The thermostats are delivered with a default setpoint of 21 °C.

The illustration below shows how to adjust the thermostat temperature setpoint.

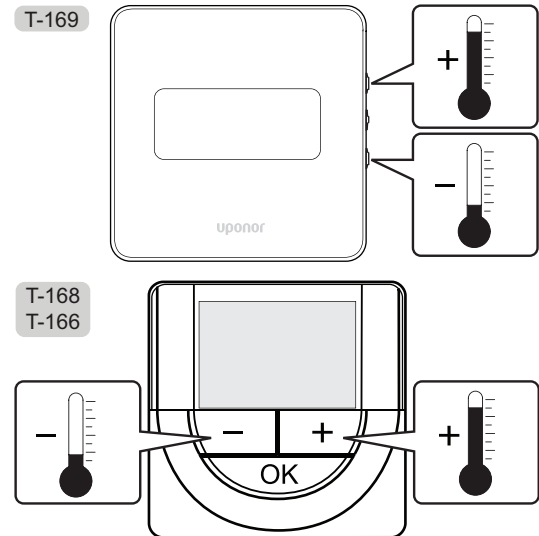

To adjust the thermostat temperature setpoint of the current control mode:

1. Press the - or + (T-169 = ▼ or ▲) button once. The screen shows the current setpoint flashing.

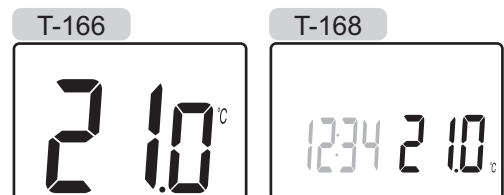
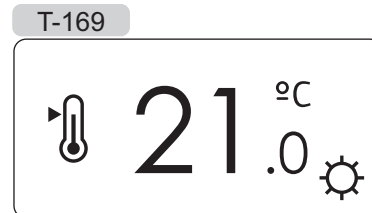

2. Press the - or + (T-169 = ▼ or ▲) button repeatedly to adjust the setpoint temperature. It will change with increments of 0.5.

When the new setpoint is set, the screen returns to run mode after a few seconds, showing the room temperature.

6.10 Register thermostats in controller

REGISTRATION AT FIRST STARTUP

When starting the controller for the first time, it automatically enters run mode, which is the standard mode of operation. Go to step 1.

REGISTRATION IF IN RUN MODE

Run mode is the standard mode of the controller when the system is running according to set parameters. Go to step 1.

REGISTRATION IF IN FORCED MODE

Exit to run mode, see section 10.4 Run mode > Exit to run mode, then go to step 1.

REGISTRATION

The illustration below shows how to register the various room thermostats associated with the controller.

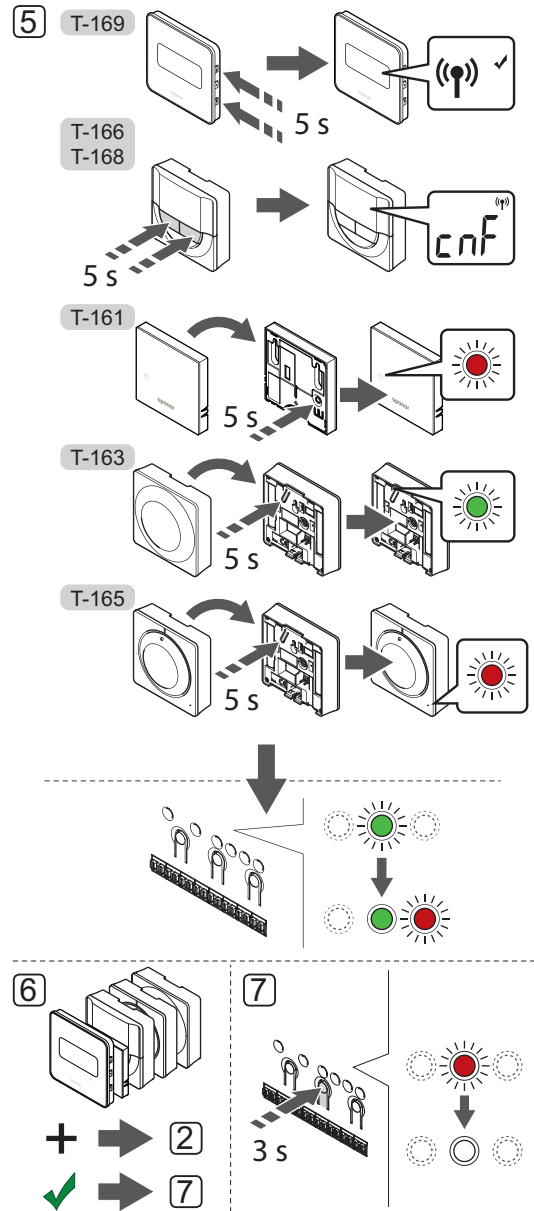
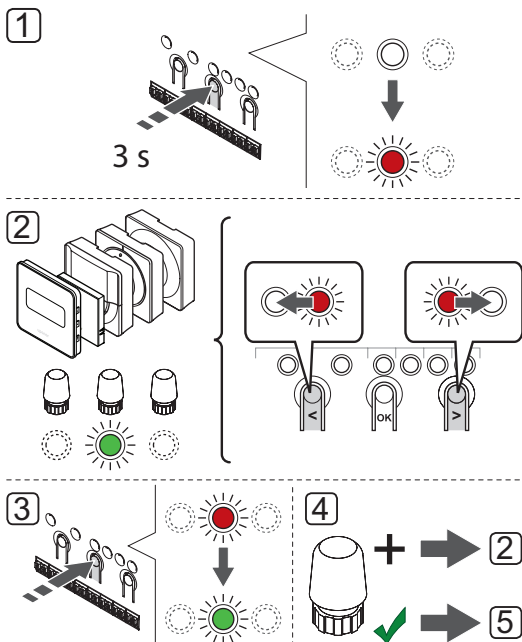

To register room thermostats in the controller:

1. Press and hold the **OK** button on the controller until the LED for channel 1 (or the first unregistered channel) flashes red.
2. Use buttons < or > to move the pointer (LED flashes red) to a preferred channel.
3. Press the **OK** button to select the channel for registration. The LED for the selected channel starts flashing green.
4. Repeat steps 2 and 3 until all channels to be registered with the thermostat are selected (LEDs flashing green).

Note! It is recommended to register all channels to the thermostat at the same time.

5. Select a thermostat

THERMOSTAT T-163

- 5.1 Optional: To activate tamper alarm during registration set the Disable timer switch to Comfort mode (☀️).
- 5.2 Gently press and hold the registration button on the thermostat, release when the LED starts flashing green (located in the hole above the registration button).
The selected channel LED in the controller turns fixed green and the registration is complete.
- 5.3 Optional: If tamper alarm was activated during registration, set the Disable timer switch to preferred mode.

THERMOSTATS T-161 AND T-165

- 5.1 Gently press and hold the registration button on the thermostat, release when the LED on the front of the thermostat starts flashing.
The selected channel LED in the controller turns fixed green and the registration is complete.

THERMOSTATS T-166 AND T-168

- 5.1 Press and hold both - and + buttons on the thermostat until the text **CnF** (configure) and a communication icon is displayed.
The selected channel LED in the controller turns fixed green and the registration is complete.

THERMOSTAT T-169

- 5.1 Press and hold both ▼ and ▲ buttons on the thermostat until the communication icon (📶) is displayed.
The selected channel LED in the controller turns fixed green and the registration is complete.
6. Repeat steps 2 through 5 until all used room thermostats are registered.
7. Press and hold the **OK** button on the controller until the green LEDs turn off to end registration and return to run mode.

To unregister already registered thermostats, see section 10.6 Unregister channels in controller.

6.11 Register system devices

In addition to room thermostats, the controller can also be connected to system devices.

Available system devices:

- Touch screen interface (optional), see section 9 Install Uponor Smatrix Wave interface for installation procedure
- Relay module
- Public thermostat with various functions

The illustration below shows how to register system devices to the controller.

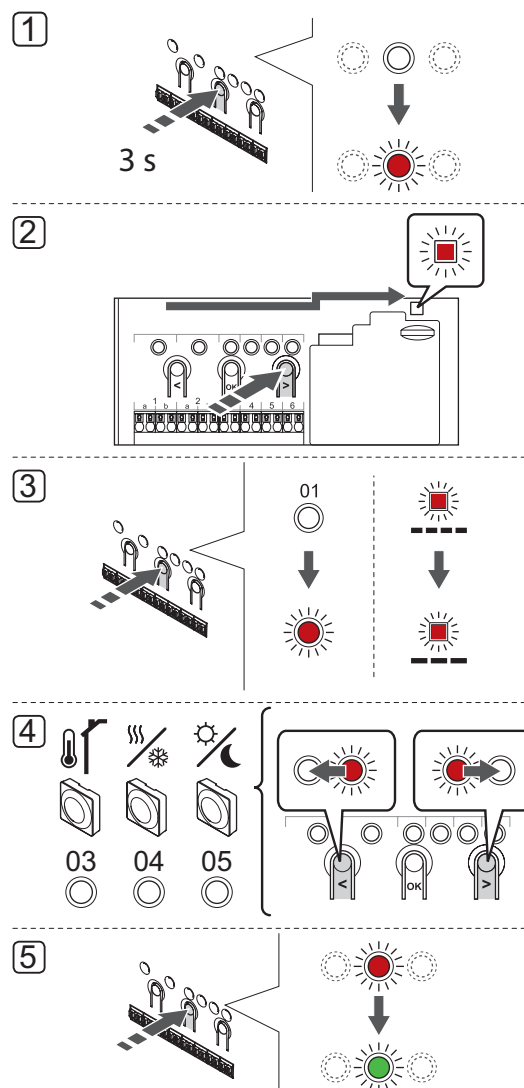

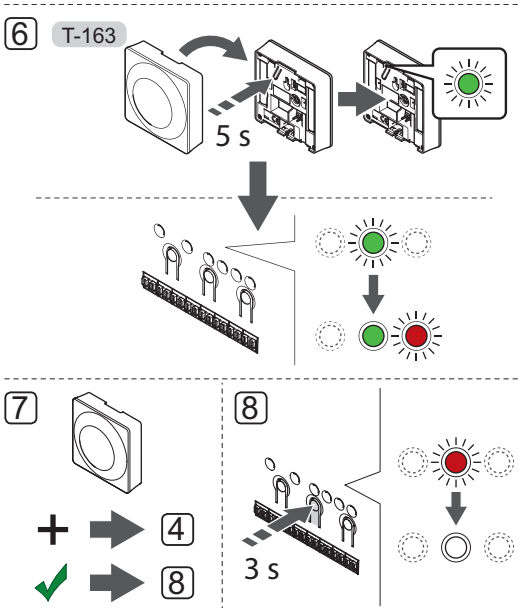

NOTE!
Registration of at least one thermostat must be done before registering a system device.

NOTE!
If registering a public thermostat T-163 as a system device with various functions, the thermostat only acts as a remote unit. It does not control the room temperature in the room where it is placed.

CAUTION!
If more than one controller is available in the system, register the thermostat as a system device to the master controller.

CAUTION!
The DIP switches in public thermostat T-163 must be set before the thermostat is registered.

CAUTION!
Make sure the controller is in run mode. For information about how to exit to run mode, see section 10.4 Run mode > Exit to run mode.

To register system devices in the controller:

1. Press and hold the **OK** button on the controller until one of the channel LEDs starts flashing.
2. Use buttons **<** or **>** to move the pointer to the power LED (LED flashes red).

3. Press the **OK** button to enter system device registration mode (power LED). The power LED starts flashing according to the pattern long blink, short pause, long blink. Channel 1 starts flashing red.
4. Use buttons **<** or **>** to move the pointer to the preferred system channel, see list below.
 - 1 = Touch screen interface
See section 9 Install Uponor Smatrix Wave interface for more information.
 - 2 = Relay module
See section 5 Install Uponor Smatrix Wave controller for more information.
 - 3 = Public thermostat with outdoor sensor.
 - 4 = Public thermostat with heating/cooling switch from contact or, heating cooling switch from sensor input (requires interface I-167).
 - 5 = Public thermostat with Comfort/ECO switch from contact
5. Press the **OK** button to select system device channel. The channel LED starts flashing green.
6. **PUBLIC THERMOSTAT T-163 AS A SYSTEM DEVICE**
 - 6.1 Gently press and hold the registration button on the thermostat, release when the LED starts flashing green (located in the hole above the registration button).
The selected channel LED in the controller turns fixed green and the registration is complete.
7. Repeat steps 4 through 6 until all system devices are registered.
8. Press and hold the **OK** button on the controller until the green LEDs turn off to end registration and return to run mode.

To unregister already registered sensors and switches, see section 10.6 Unregister channels in controller.

7 Install Uponor Smatrix Wave thermostatic head

The following thermostatic head can be connected to the system:



Uponor Smatrix Wave T-162
(thermostatic head T-162)

7.1 Placement of thermostatic head

Refer to the installation preparation guidelines (see section 4.2 *Prepare for installation*), and use the following guidelines when positioning the thermostatic heads:

1. Install the thermostatic head on a hydraulic radiator only.
2. Ensure that the thermostatic head is away from direct solar radiation.
3. Ensure that the thermostatic head is away from any source of humidity and water splashes (IP20).
4. Ensure that the thermostatic head is positioned at least 40 cm away from the controller to avoid interference.

7.2 Label thermostatic heads

Label the thermostatic heads, where suitable, with the channel numbers they are connected to, for example, #02, #03. For a system with interface and several controllers, add the ID of each controller, for example, 1.02, 1.03, 2.02, 2.03.

7.3 Insert batteries

All thermostatic heads use two alkaline 1.5 V AA batteries which provides about 2 years of battery life, as long as they are positioned within radio range of the controller. Ensure that the batteries are correctly inserted in the thermostatic heads.

The thermostatic head will perform a self test, for about 10 seconds, when the batteries have been inserted. The system will be blocked for input.

The illustration below shows how to remove the plastic transportation strip from the batteries, starting the thermostatic head.

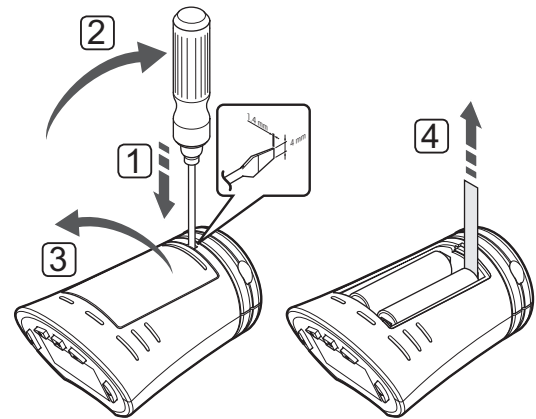

7.4 Install thermostatic head on hydraulic radiator

The thermostatic heads are delivered in kits including adapters, plastic brackets, and screws.



CAUTION!

The thermostatic head must be installed on a radiator before registering it to a controller. Because the thermostatic head will perform a valve stroke calibration, when registered, to accurately operate the valve on the radiator.

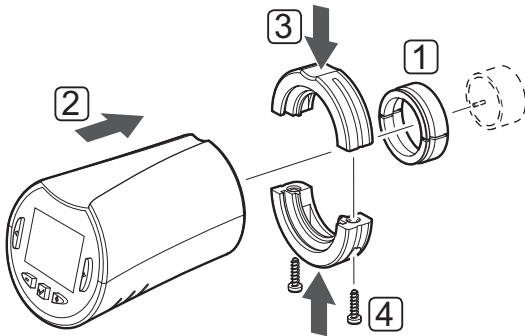

To install a thermostatic head on a hydraulic radiator:

1. Mount the adaptor on the hydraulic radiator. Threaded M28 or M30 adaptors are delivered with the thermostatic head.
2. Hold the thermostatic head to the adaptor.
3. Fix the plastic brackets to the adaptor and thermostatic head.
4. Fix the plastic brackets with the two screws.

7.5 First startup of thermostatic head

At first startup, before registering, the thermostatic head shows two types of information in its display.

1. Current software version is displayed during power up.

T-162

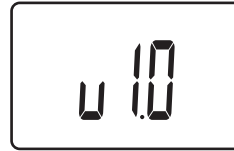

2. When powered up, the display switches to a message showing the thermostatic head is not registered to a controller.

T-162

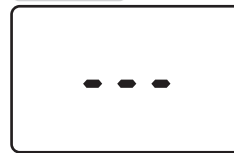

7.6 First setup of thermostatic head

TEMPERATURE SETPOINT

The temperature, in rooms without a thermostat, is changed by adjusting the setpoint on the thermostatic head.

Use the - or + buttons on the thermostatic head to adjust the temperature. The display will light up when pushing a button. It shuts off after about 10 seconds of inactivity.

The illustration below shows how to adjust the thermostatic head temperature setpoint.

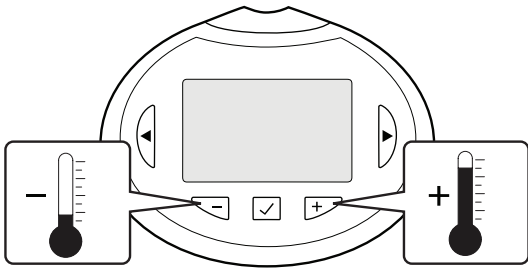

To adjust the temperature setpoint of the current control mode on the thermostatic head:

1. Press the - or + button once.

The screen shows the current setpoint flashing.

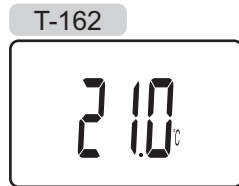

2. Press the - or + button repeatedly to adjust the setpoint temperature. It will change with increments of 0.5.

When the new setpoint is set, the screen returns to run mode after a few seconds, showing the room temperature.

SELECT TEMPERATURE DISPLAY UNIT

To change the temperature display mode:

! NOTE!

If no button is pressed for about 8 seconds, while in a menu, the current values will be saved and the software exits to run mode.

1. Press and hold the **OK** button until the settings icon and menu numbers (**08**) is displayed in the top right corner of the display (about 3 seconds).
2. Press **OK** and the parameter starts flashing.
3. Use buttons - or + to toggle between Celsius and Fahrenheit.

dEg °C – degrees Celsius (default)

dEg °F – degrees Fahrenheit

4. Press **OK** to confirm the change and return to the settings menu.

7.7 Register thermostatic heads in controller to rooms with a thermostat

The illustration below shows how to register the thermostatic head to the controller.

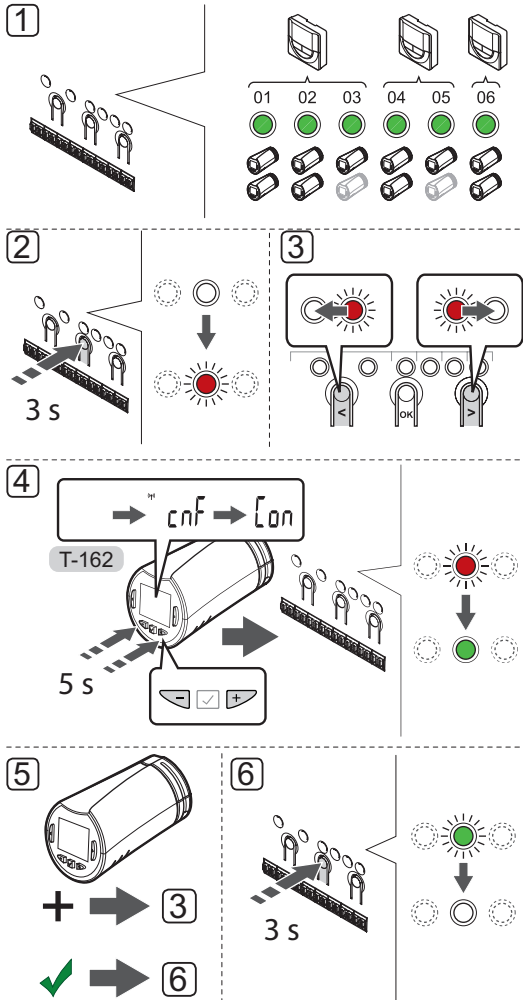

NOTE! The thermostat in control of the thermal heads should not also control under floor heating. Make notes to make sure

NOTE! If two thermostatic heads already have been registered to a channel, register the third to the next channel in line. If more thermostat channels are needed they can be added in thermostat registration mode.

NOTE! There is no indication showing if a thermostatic head already is registered to a channel.

CAUTION!

The thermostatic head must be installed on a radiator before registering it to a controller. Because the thermostatic head will perform a valve stroke calibration, when registered, to accurately operate the valve on the radiator.

To register thermostatic heads in the controller:

1. A thermostat must be registered to a sufficient number of channels to be able to control all thermostatic heads in a room. A maximum of two thermostatic heads can be registered per channel.
See section 6.10 Register thermostats in controller for more information.
2. Press and hold the **OK** button on the controller until the LED for the first unregistered channel flashes red. If all channels are registered to thermostats, the LED flashes red and green.
3. Use buttons **<** or **>** to move the pointer (LED flashes red) to the intended thermostat channel (green LED). The LED flashed red and green.

If the first channel is full, move the pointer to the next thermostat channel in line.

4. THERMOSTATIC HEAD T-162

- 4.1 Press and hold both **-** and **+** buttons on the thermostatic head until the text **CnF** (configure) and a communication icon is displayed. The text **Con** is shown in the display, and the selected channel LED in the controller turns fixed green, when the registration is complete.

Note! If the text --- is shown in the thermostatic head display the registration failed. Repeat steps 2 through 3 and try the next channel in line, in case two other thermostatic heads already has been registered to the current one.

5. Press one of the buttons on the controller and repeat steps 3 through 4 until all thermostatic heads are registered.
6. Press and hold the **OK** button on the controller until the green LEDs turn off to end registration and return to run mode.

To unregister already registered thermostatics heads the controlling thermostat must be unregistered, *see section 10.6 Unregister channels in controller.*

7.8 Register thermostatic heads to controller in rooms without a thermostat

The illustration below shows how to register the thermostatic head to the controller.

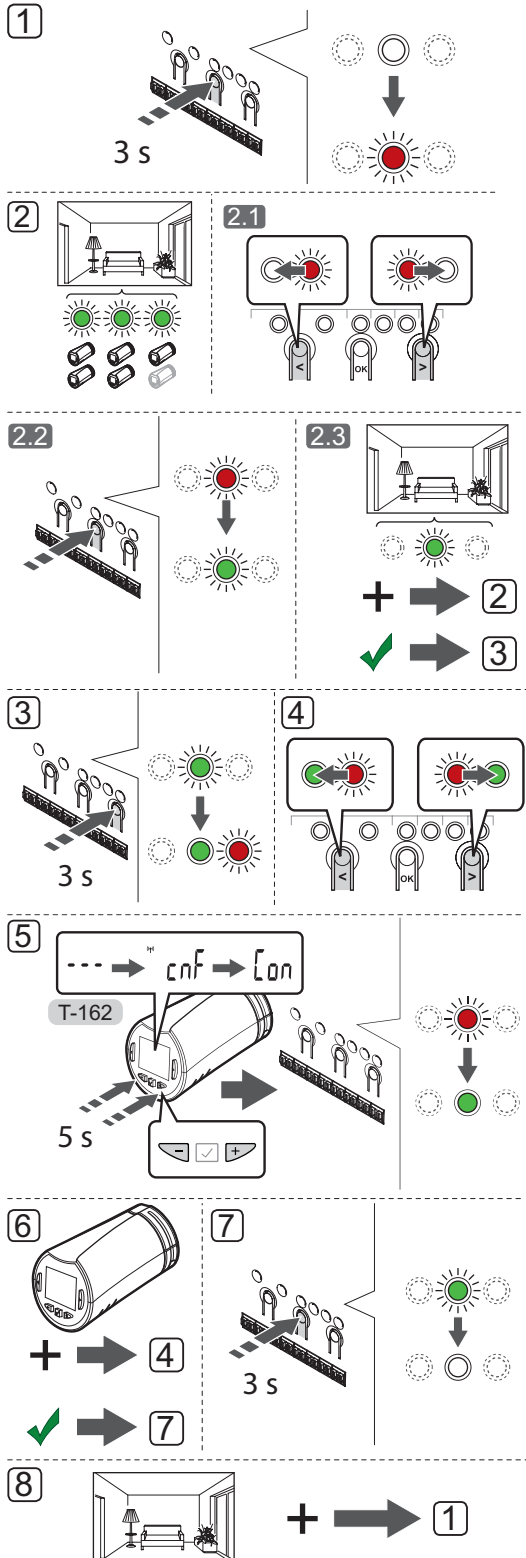

NOTE!

If two thermostatic heads already have been registered to a channel, register the third to the next channel in line. If more thermostat channels are needed they can be added in thermostat registration mode.

NOTE!

There is no indication showing if a thermostatic head already is registered to a channel.

CAUTION!

The thermostatic head must be installed on a radiator before registering it to a controller. Because the thermostatic head will perform a valve stroke calibration, when registered, to accurately operate the valve on the radiator.

To register thermostatic heads in the controller:

- Press and hold the **OK** button on the controller until the LED for the first unregistered channel flashes red. If all channels are registered to thermostats, the LED flashes red and green.
- Select a thermostat channel.
 - Use buttons **<** or **>** to move the pointer (LED flashes red) to the first empty channel needed for the room (no LED). The LED flashed red.
 - Press the **OK** button to select the channel for registration. The LED for the selected channel starts flashing green.
 - Repeat steps 2.1 and 2.2 until a sufficient number of channels for the room are created.
- Press and hold the **>** button on the controller until the selected channels light up green and the next in line starts flashing red. A channel without a thermostat has been created.
- Use buttons **<** or **>** to move the pointer (LED flashes red) to the first channel of the room (green LED). The LED flashed red and green.

If the first channel is full, move the pointer to the next channel in line.

5. THERMOSTATIC HEAD T-162

5.1 Press and hold both **-** and **+** buttons on the thermostatic head until the text **CnF** (configure) and a communication icon is displayed.

The text **Con** is shown in the display, and the selected channel LED in the controller turns fixed green, when the registration is complete.

Note! If the text --- is shown in the thermostatic head display the registration failed. Repeat steps 2.1 through 2.2 and try the next channel in line, in case two other thermostatic heads already has been registered to the current one.

6. Press one of the buttons on the controller and repeat steps 4 through 5 until all thermostatic heads are registered.
7. Press and hold the **OK** button on the controller until the green LEDs turn off to end registration and return to run mode.
8. Repeat steps 1 through 7 until the thermostatic heads in all rooms are registered.

To unregister already registered thermostatic heads the controlling thermostat must be unregistered, *see section 10.6 Unregister channels in controller.*

8 Install Uponor Smatrix Wave interface

The following interfaces can be connected to the system:



Uponor Smatrix Wave I-167
(interface I-167)

Up to four controllers can be registered and controlled by the interface.

8.1 Placement of interface

Refer to the installation preparation guidelines (see section 4.2 *Prepare for installation*), and use the following guidelines when positioning the interface:

1. Select an indoor wall and a position 1.3 m to 1.5 m above the floor.
2. Ensure that the interface is away from direct solar radiation.
3. Ensure that the interface will not be heated through the wall from sunshine.
4. Ensure that the interface is away from any source of heat, for example television set, electronic equipment, fireplace, spotlights, and so on.
5. Ensure that the interface is away from any source of humidity and water splashes (IP20).
6. Ensure that the interface is positioned at least 40 cm away from the controller to avoid interference.

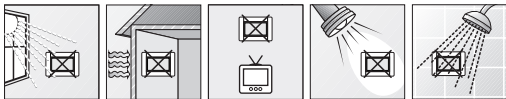
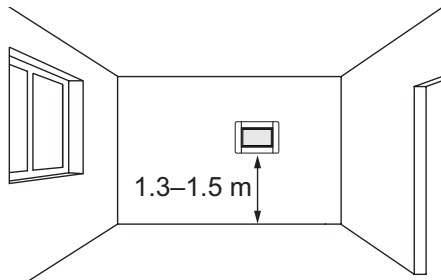

8.2 Attach the interface to the wall

USING WALL BRACKET (RECOMMENDED)

The illustration below shows mounting hole positions on the wall bracket, how to attach the interface, and how to connect power.



WARNING!

Electrical installation and service behind secured 230 V AC covers must be carried out under the supervision of a qualified electrician.

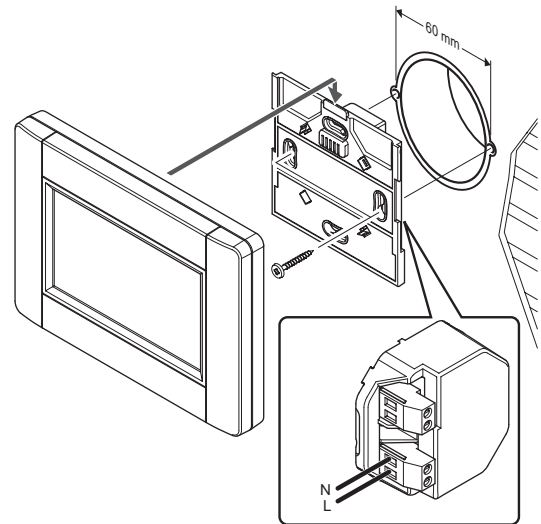

USING TABLE STAND

The illustration below shows mounting hole positions using the table stand, how to modify the table stand, and how to attach the interface.



NOTE!

Parts of the table stand must be modified before mounting it on a wall.

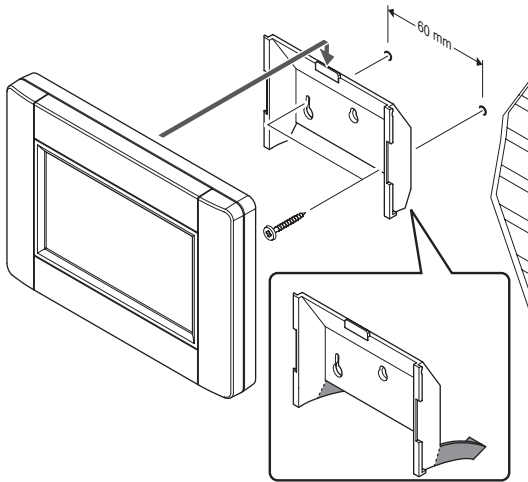

8.3 Attach to table stand

The illustration below shows how to attach the interface to a table stand.

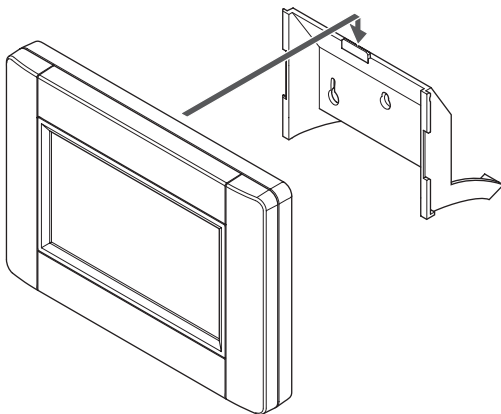

8.4 Charger cable

The interface is charged when attached to the wall bracket, but if needed a standard mini-USB cable can be used.

The illustration below shows where to attach the cable.

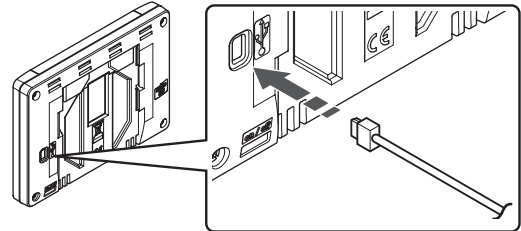

8.5 Startup guide

When starting the interface for the first time, or after a factory reset, a startup guide is shown in the touch screen display.



NOTE!

Set the controller is in system device registration mode before powering up the interface.

POWER UP THE INTERFACE

The power switch is located on the lower left corner on the back of the interface. The interface will power up when connected to a power source.

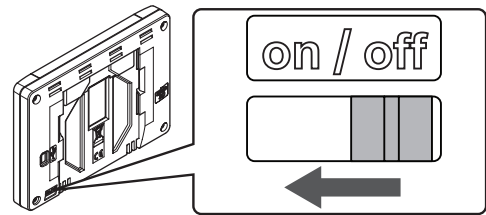











The startup guide uses the following order:

No	Description
1	Set language
2	Set regional settings
3	Set date and time
4	Set system to heating and/or cooling
5	Register the interface to a controller

All these settings are accessible in the interface menu system.

Navigating the interface:

Icon	Description
	Go to home menu
	Go back/cancel changes (if not saved)
	Scroll up and down in lists
	Scroll sideways or change sub menu (if available)
	Cancel settings and return to previous menu
	Move to the previous field
	Decrease value
	Increase value
	Move to the next field
	Confirm settings and return to previous menu or continue to next step in startup guide
	Settings Appears in some menus where more specific settings are available for a parameter

See section 16 Operate Uponor Smatrix Wave interface for more information.

SET LANGUAGE

Interaction with the interface can be done in several languages. The most commonly used languages are already loaded in the interface, but more are available with the supplied microSD card inserted.

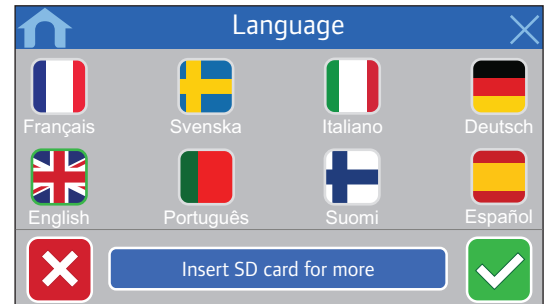

1. Select preferred language from the list by pressing a flag symbol.
2. Confirm and continue to the next step in the startup guide.

SET REGIONAL SETTINGS

Set regional settings for date and time.

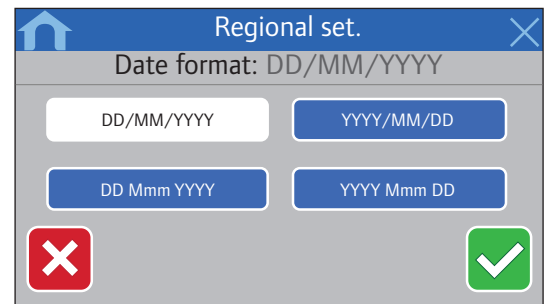

1. Select preferred date format.
2. Confirm and continue to the next step in the startup guide.

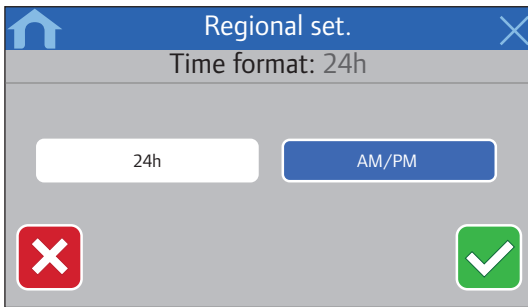

3. Select preferred time format.
4. Confirm and continue to the next step in the startup guide.

SET DATE AND TIME

Set the date and time of the system.

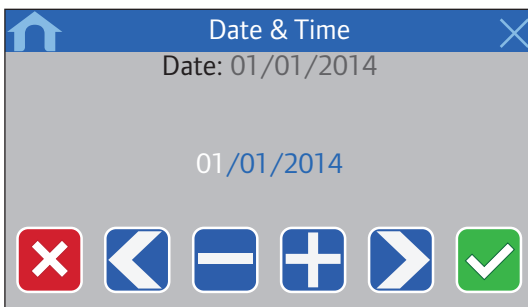

1. Set the current date.
2. Confirm and continue to the next step in the startup guide.

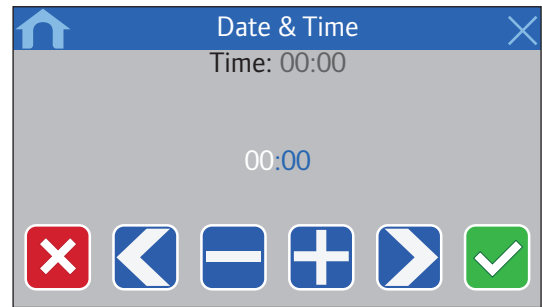

3. Set the current time.
4. Confirm and continue to the next step in the startup guide.

SELECT IF COOLING IS AVAILABLE IN THE SYSTEM

Set whether cooling is available in the system or not.

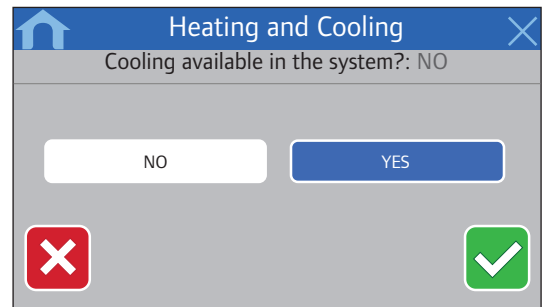

1. Select if cooling is available in the system.
2. Confirm and continue to the next step in the startup guide.

REGISTER THE INTERFACE TO A CONTROLLER

The interface must be registered to a controller to be able to control the connected system.

Up to four controllers can be registered and controlled by the interface.

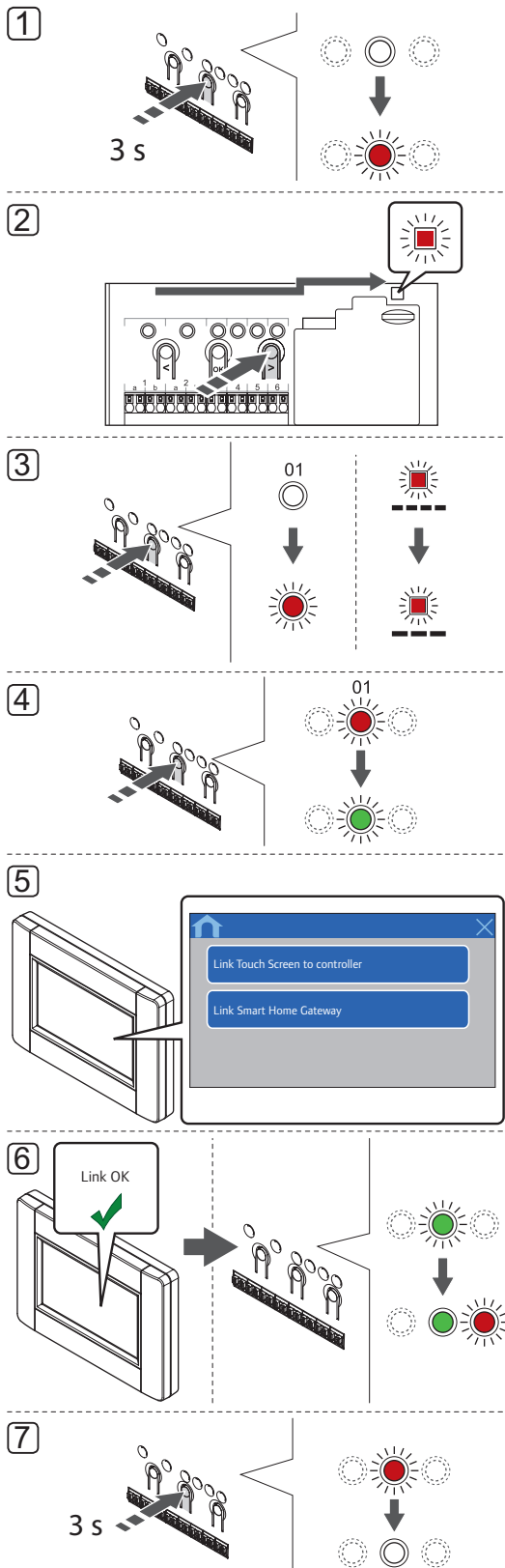

NOTE!

Registration of at least one thermostat must be done before registering an interface.



CAUTION!

Make sure the controller is in run mode. For information about how to exit to run mode, see section 10.4 Run mode > Exit to run mode.

To register the interface to a controller:

1. Press and hold the **OK** button on the controller until one of the channel LEDs starts flashing.
2. Use buttons **<** or **>** to move the pointer to the power LED (LED flashes red).
3. Press the **OK** button to enter system device registration mode (power LED). The power LED starts flashing according to the pattern long blink, short pause, long blink. Channel 1 starts flashing red.
4. Press the **OK** button to select Channel 1. The channel LED starts flashing green.

5. USING THE INTERFACE START GUIDE:

- 5.1 Follow the instructions in section 8.5 Startup guide until the button **Link Touch Screen to controller** appears.
- 5.2 Press **Link Touch Screen to controller** to initialize registration.

USING THE INTERFACE MENU SYSTEM:

- 5.1 Go to the **RF Link** menu (**Main menu > Preferences**).
- 5.2 Press **Link Touch Screen to controller** to initialize registration.
6. The interface gets registered to the controller. The selected channel LED in the controller turns fixed green and the registration is complete.
7. Press and hold the **OK** button on the controller until the green LEDs turn off to end registration and return to run mode.

To unregister an already registered interface, see section 10.6 Unregister channels in controller.

9 Finishing installation

Make a complete check up of the installation:

1. Check that the thermostats, and thermostatic heads (if installed), are working correctly.

Turn thermostat setpoints to maximum to obtain a heating demand and make sure that the actuators are running.

2. Set thermostats and optional interface to the defined operating settings.
3. Close the covers of the controller.
4. Attach thermostats and optional interface to the wall.
5. Print and fill in the "Installation report" located at the end of the manual.
6. Give the manual and all information about the system to the user.

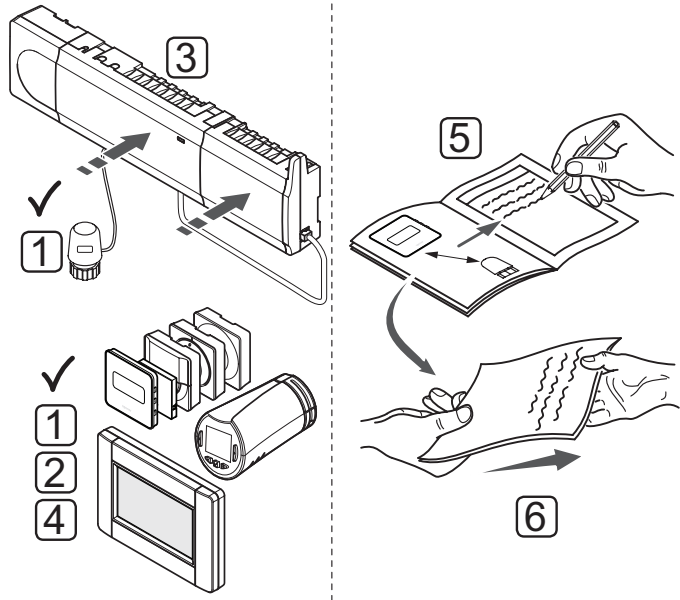

10 Operate Uponor Smatrix Wave controller

Uponor Smatrix Wave controls the underfloor heating/cooling installation according to customer needs. Temperatures can be adjusted with thermostats located in each room, or if installed with an optional touch screen interface.

10.1 Principle of operation

As soon as the temperature measured at a thermostat is lower (heating mode) or higher (cooling mode) than the setpoint temperature, a demand to change the room temperature is created and sent to the controller. The controller will open the actuators according to current operating mode and other settings. Once the set temperature is reached, this information is sent and the actuators are closed.

10.2 Normal operation without optional scheduling programs

When the system is running in normal mode:

- In **Heating mode**, the actuators are open when room temperatures are lower than the temperatures set on the thermostats.
- In **Cooling mode**, the actuators are open when room temperatures are higher than the temperatures set on the thermostats.

For information about operating the interface, see section 16 Operating Uponor Smatrix Wave interface.

For information about operating the analogue thermostats, see section 12 Operating Uponor Smatrix Wave analogue thermostat.

For information about operating the digital thermostats, see section 13 Operating Uponor Smatrix Wave digital thermostat.

For information about operating the thermostatic heads, see section 15 Operating Uponor Smatrix Wave thermostatic head.

10.3 Operation with scheduling programs

Scheduling programs provide an option to switch selected rooms between Comfort and ECO mode using a 7-day program. This optimises the installation and conserves energy.

The use of scheduling programs requires at least one of:

- Uponor Smatrix Wave T-168 (programmable thermostat)
- Uponor Smatrix Wave I-167 (optional interface)

For information about operating the thermostat, see section 13 Operating Uponor Smatrix Wave digital thermostats.

For information about operating the interface, see section 16 Operating Uponor Smatrix Wave interface.

10.4 Run mode

During normal operation the controller is in run mode.

EXIT TO RUN MODE

If the controller is in registration or forced mode, exit to run mode by pressing the **OK** button until the LEDs turn off (about 3 seconds).

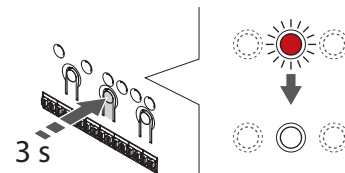

10.5 Reset the controller

If problems, such as inaccurate channel registration exist, reset the controller. The following illustration shows the location of the reset button in the controller.

To reset the controller:

1. Make sure the controller is in run mode. If it is in registration or forced mode, press and hold the **OK** button for about 5 seconds or until the LEDs turn off.
2. Press the **<**, **OK**, and **>** buttons simultaneously (for about 10 seconds) until the power LED flashes, and all channel LEDs turn off. All parameters are erased and run mode has been activated.

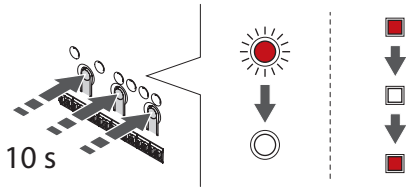

3. Installation and registration are required after resetting the controller.

10.6 Unregister channels in the controller

UNREGISTER ONE CHANNEL

When a channel is inaccurately registered or if a thermostat registration needs to be redone, it is possible to remove the current registration from the controller.

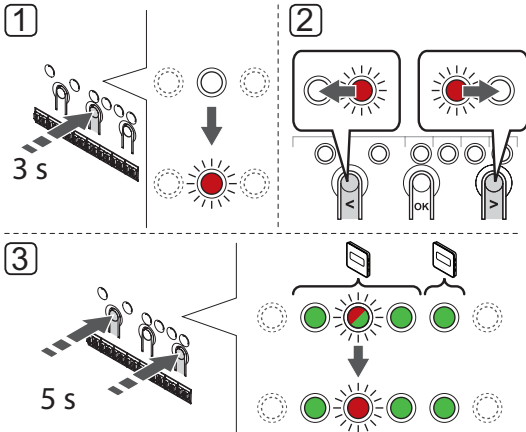

CAUTION!

Make sure the controller is in run mode. For information about how to exit to run mode, see section 10.4 Run mode > Exit to run mode.

To unregister a channel:

1. Press and hold the **OK** button on the controller until the LED for channel 1 flashes red/green, or the first unregistered channel flashes red.
2. Use buttons **<** or **>** to move the pointer (LED flashes red) to the selected channel (flashes green if registered) to unregister.
3. Press the **<** and **>** buttons simultaneously until the LED for the selected channel starts flashing red (about 5 seconds).

UNREGISTER ALL CHANNELS

When one or more channels are inaccurately registered, it is possible to remove all registrations at the same time, as shown in the illustration below.



NOTE!

The controller must be unregistered in the interface as well. Go to menu **Main menu > Preferences > Link** and unregister.

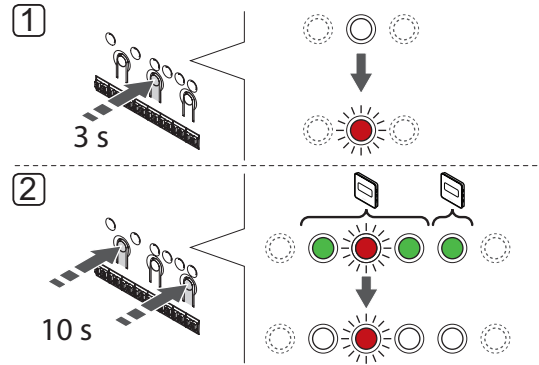

CAUTION!

Make sure the controller is in run mode. For information about how to exit to run mode, see section 10.4 Run mode > Exit to run mode.

To cancel all channel registrations:

1. Press and hold the **OK** button on the controller until the LED for channel 1 flashes red/green, or the first unregistered channel flashes red.
2. Press the **<** and **>** buttons simultaneously until the LEDs for all channels except one turn off (about 10 seconds). The one remaining flashes red.

UNREGISTER A SYSTEM DEVICE

When a channel is inaccurately registered to a system device, it is possible to remove the registration, as shown in the illustration below.

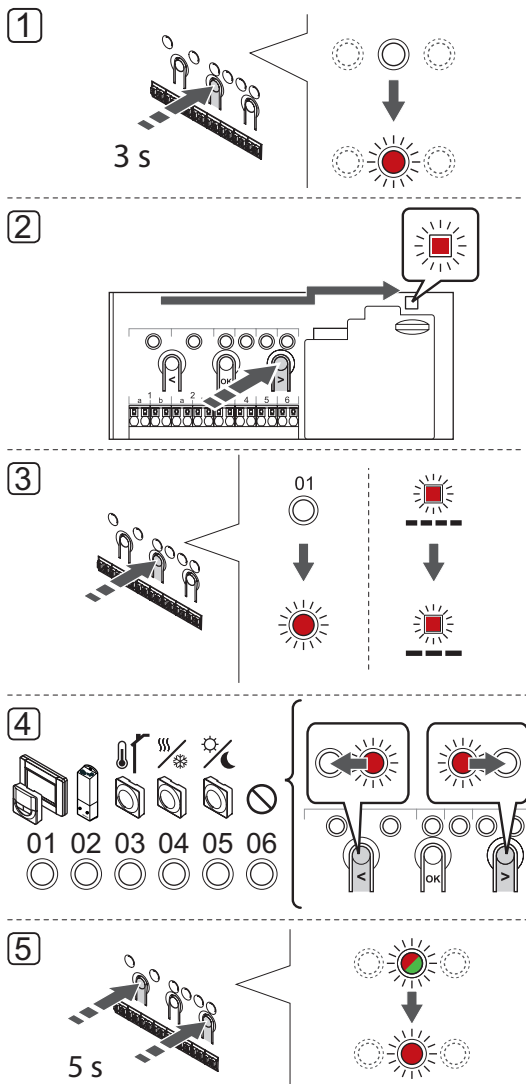

NOTE!

The controller must be unregistered in the interface (optional) as well. Go to menu **Main menu > Preferences > Link** and unregister.



CAUTION!

Make sure the controller is in run mode. For information about how to exit to run mode, see section 10.4 Run mode > Exit to run mode.

To unregister a system device:

1. Press and hold the **OK** button on the controller until one of the channel LEDs starts flashing.
2. Use buttons **<** or **>** to move the pointer to the power LED (LED flashes red).
3. Press the **OK** button to enter system device registration mode. The power LED starts flashing according to the pattern long blink, short pause, long blink. Channel 1 starts flashing red, or red/green if a device is registered to that channel.
4. Use buttons **<** or **>** to move the pointer (LED flashes red) to the selected channel (flashes green if registered), see the following list.
 - 1 = Touch screen interface
 - 2 = Relay module
 - 3 = Public thermostat with outdoor sensor
 - 4 = Public thermostat with heating/cooling switch from contact, or heating cooling switch from sensor input (requires interface I-167).
 - 5 = Public thermostat with Comfort/ECO switch
5. Press the **<** and **>** buttons simultaneously for about 5 seconds until the LED for the selected channel start flashing red.



10.7 Update controller software (optional)

Software and update instructions can be found on the Uponor website.

11 Operate Uponor Smatrix Wave analogue thermostats

Two types of thermostats, both analogue and digital, can be used in an Uponor Smatrix Wave system.

Analogue thermostats:

	Uponor Smatrix Wave T-165 (standard thermostat T-165)
	Uponor Smatrix Wave T-163 (public thermostat T-163)
	Uponor Smatrix Wave T-161 (sensor thermostat T-161)

The analogue thermostats are controlled by either turning a dial (T-165), adjusting a potentiometer on its back (T-163), or via interface I-167 (T-161, T-163, and T-165).

11.1 Thermostat layout

ROOM SENSOR THERMOSTAT T-161

During normal operation the thermostat is monitored and controlled via interface I-167.

The illustration below shows the parts of the thermostat.

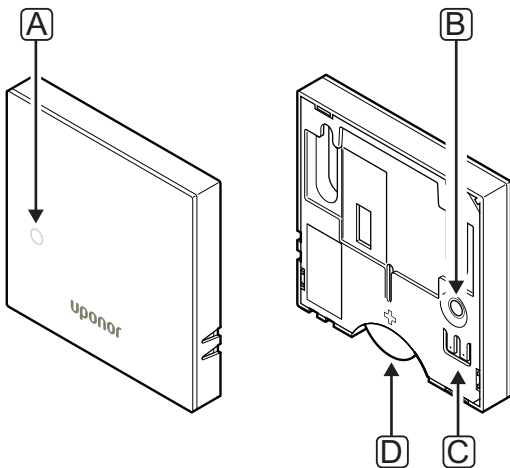

Item	Description
A	Low battery level LED (flashes once every two hours)
B	Registration button
C	Terminal for external sensor (non-polarised)
D	Battery

PUBLIC THERMOSTAT T-163

During normal operation a discreet LED on the back of the thermostat is lit for about 60 seconds if there is a demand for heating or cooling.

The thermostat contains a switch that, if activated during registration, sends an alarm when the thermostat is removed from the wall. The alarm is transmitted by radio, causing the related channel LEDs on the controller to flash.

The illustration below shows the parts of the thermostat.

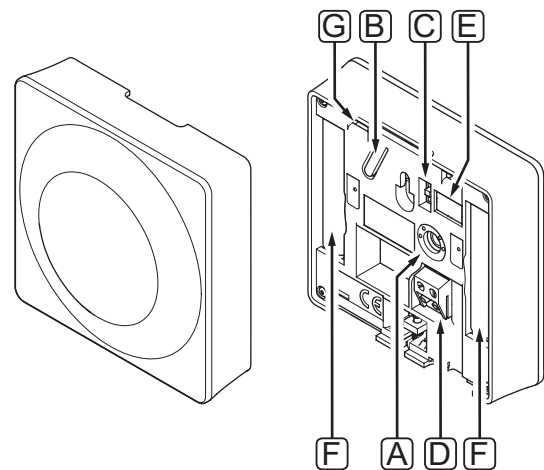

Item	Description
A	Setpoint temperature potentiometer
B	Registration button
C	Disable timer switch
D	Terminal for external sensor (non-polarised)
E	Configuration DIP switches
F	Batteries
G	Heating/cooling demand LED

STANDARD THERMOSTAT T-165

During normal operation a discreet LED on the thermostat is lit for about 60 seconds if there is a demand for heating or cooling.

The illustration below shows the parts of the thermostat.

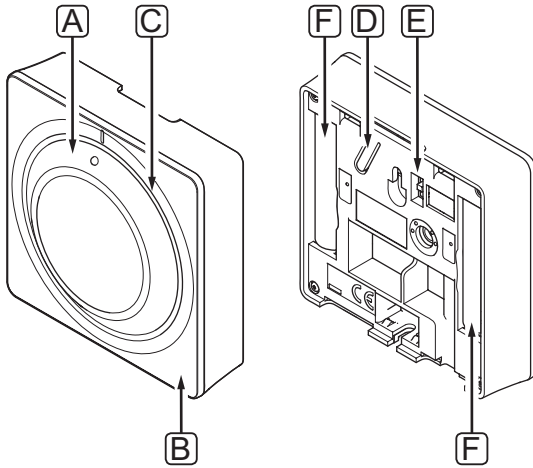

Item	Description
A	Room temperature setpoint dial control
B	Heating/cooling demand LED
C	Backlight
D	Registration button
E	Disable timer switch
F	Batteries

11.2 Adjust temperature

The temperature is changed by adjusting the setpoint on the thermostat to a value between 5 and 35 °C. It is possible to set minimum and maximum temperature limits using an interface (optional).

ROOM SENSOR THERMOSTAT T-161

The setpoint for thermostat T-161 can only be changed via interface I-167. If the interface I-167 is not connected, the setpoint will be fixed to 21 °C.

PUBLIC THERMOSTAT T-163

The illustration below shows how to adjust the thermostat temperature setpoint.

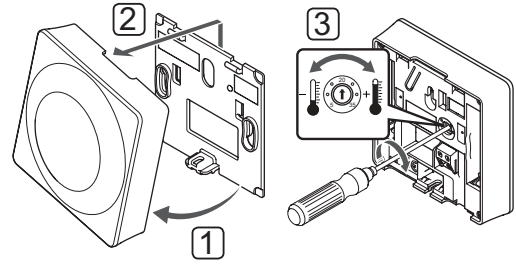

To change the thermostat temperature setpoint:

1. Angle the thermostat from the bracket.
2. Remove it from the wall.
3. Set the desired temperature using the potentiometer.
4. Put the thermostat back on the wall.

STANDARD THERMOSTAT T-165

Use the dial on the thermostat to adjust the temperature. A backlight will light up when twisting the dial. It shuts off after about 10 seconds of inactivity.

The illustration below shows how to adjust the thermostat temperature setpoint.

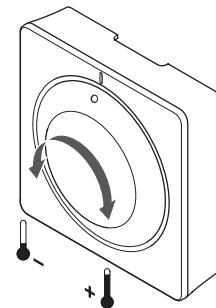

To adjust the thermostat temperature setpoint:

- Twist the dial clockwise for a higher temperature.
- Twist the dial counter-clockwise for a lower temperature.

11.3 Disable timer function (T-163 and T-165 only)

Thermostats T-163 and T-165 have switches on their backs allowing the user to disable the timer function (Comfort mode) for the channels controlled by the thermostat. The switch is set to **Comfort/ECO** from the factory.

The illustration below shows how to disable the timer function on the thermostat.

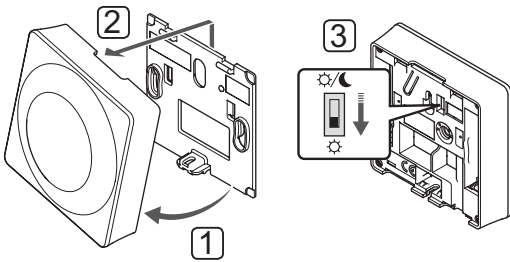

To change the switch to **Disable timer**:

1. Angle the thermostat from the bracket.
2. Remove it from the wall.
3. Switch to Comfort mode, .
4. Put the thermostat back on the wall.

11.4 Replace batteries

THERMOSTAT T-161

Replace the battery of the thermostat when the LED flashes (once every two hours).

The thermostat will perform a self test, for about 10 seconds, when the battery have been inserted. The system will be blocked for input and the thermostat LED flashes during this period.

The illustration below shows how to replace the battery.

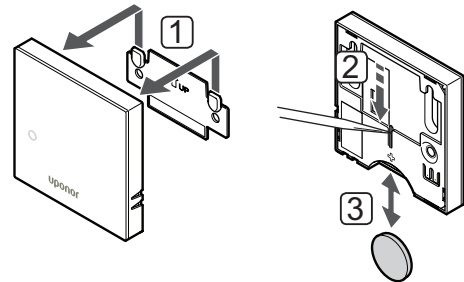

1. Remove the thermostat from the wall.
2. Use a pointed object to remove the battery.
3. Replace the battery.

THERMOSTATS T-163 AND T-165

Replace the batteries of the thermostat when the LED flashes twice during a heating or cooling demand.

The thermostat will perform a self test, for about 10 seconds, when the batteries have been inserted. The system will be blocked for input and the thermostat LED flashes during this period.

The illustration below shows how to replace the batteries.

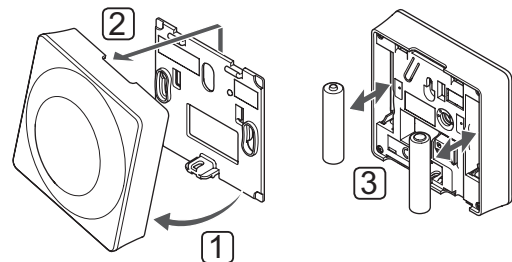

1. Angle the thermostat from the bracket.
2. Remove it from the wall.
3. Replace batteries.

11.5 Factory reset

Factory reset sets all parameter values to default settings.



NOTE!

Do not factory reset the thermostat if not absolutely needed.



NOTE!

A factory reset removes the registration data from the thermostat.

THERMOSTAT T-161

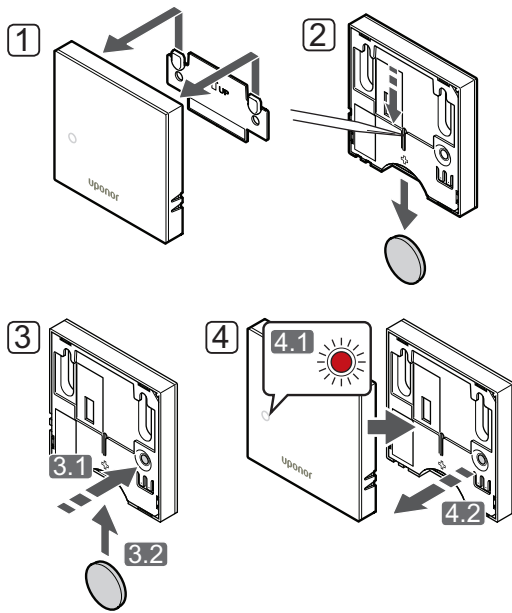

To factory reset the thermostat:

1. Remove the thermostat from the wall.
2. Remove the battery from the thermostat.
3. Press and hold the registration button on the thermostat while inserting the battery again.
4. Release the button after about 10 seconds when the LED start flashing.
5. The thermostat is now reset to factory default.

THERMOSTATS T-163 AND T-165

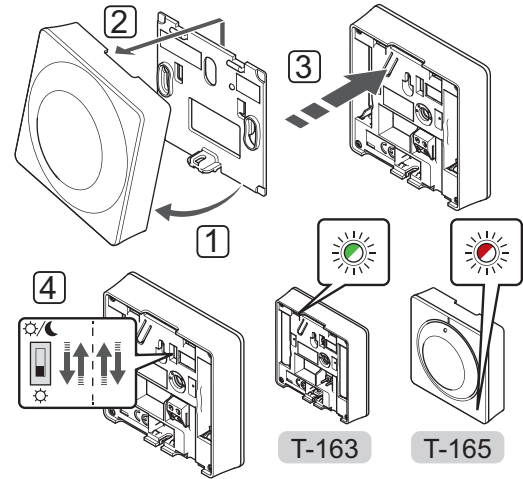

To factory reset the thermostat:



1. Angle the thermostat from the bracket.
2. Remove it from the wall.
3. Gently press and hold the registration button on the thermostat, release when the demand LED starts flashing.
4. Change the Disable timer switch twice, regardless of starting position.
5. The thermostat is now reset to factory default.

12 Operate Uponor Smatrix Wave digital thermostats

Two types of thermostats, both analogue and digital, can be used in an Uponor Smatrix Wave system.

The digital thermostats have a display relaying information to the user and buttons for control.

Digital thermostats:

	Uponor Smatrix Wave T-169 (digital thermostat with RH T-169)
	Uponor Smatrix Wave T-168 (programmable thermostat with RH T-168)
	Uponor Smatrix Wave T-166 (digital thermostat T-166)

12.1 Thermostat layout

THERMOSTAT T-169

The illustrations below shows the parts of the thermostat.

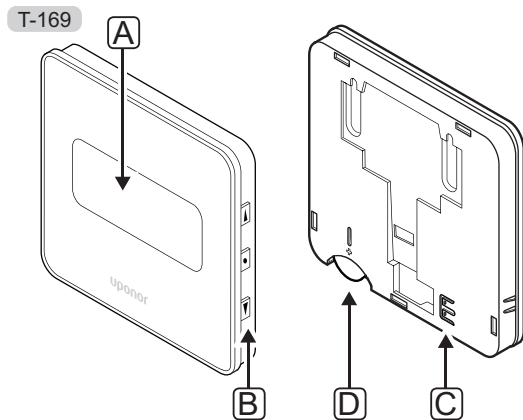

Item	Description
A	Display
B	Buttons
C	Terminal for external sensor (non-polarised)
D	Battery

THERMOSTATS T-166 AND T-168

The illustrations below shows the parts of the thermostat.

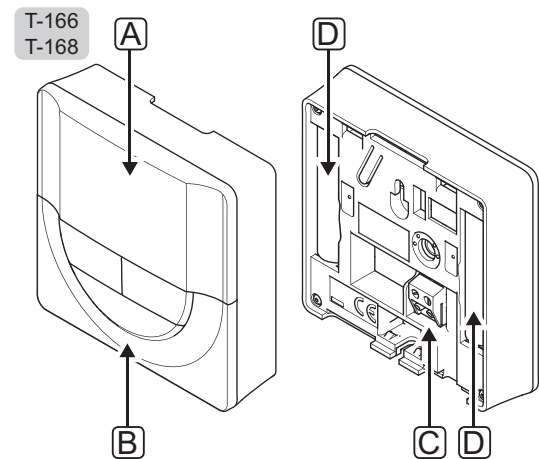

Item	Description
A	Display
B	Buttons
C	Terminal for external sensor (non-polarised)
D	Batteries

12.2 Display layout

THERMOSTAT T-169

The figures shows different display screens and the different symbols that can be shown.

Run mode (default screen)

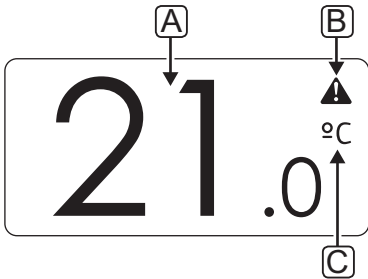

Pos.	Icon	Description
A	21.0	Temperature reading using a - or + sign, two digital characters, a decimal point and a character showing either 0 or 5
B	!	Alarm symbol
C	°C °F	Temperature unit

Change setpoint

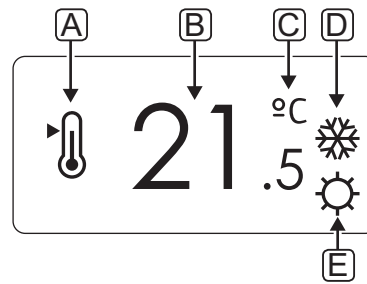

Pos.	Icon	Description
A	🌡️	Change setpoint mode
B	21.5	Temperature setpoint, using a - or + sign, two digital characters, a decimal point and a character showing either 0 or 5
C	°C °F	Temperature unit
D	🔥 ❄️	Heating demand Cooling demand
E	☀️ 🌙	Comfort mode ECO mode

Alarms

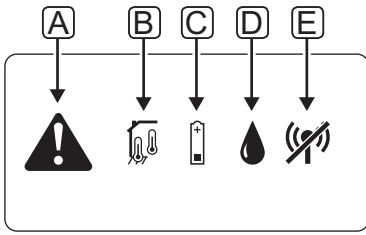

Pos.	Icon	Description
A		Alarm mode
B		Faulty indoor temperature sensor
		Faulty floor temperature sensor
		Faulty remote temperature sensor
		Faulty outdoor temperature sensor
C		Low battery indicator
D		Relative humidity limit reached
E		Communication fault indicator

Control mode

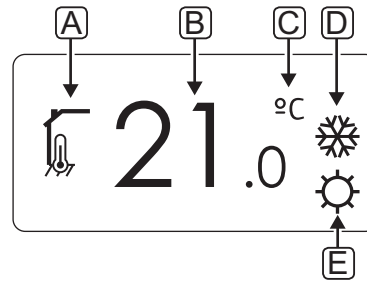

Pos.	Icon	Description
A		Current control mode
		Indoor temperature indicator
		Current control mode
		Indoor temperature with floor temperature limitation indicator
		Current control mode
		Remote sensor temperature indicator
B		Current control mode
		Outdoor temperature indicator
C		Temperature unit, shown when the character group A shows a temperature
		Temperature unit
D		Temperature unit
		Heating demand
E		Cooling demand
		Comfort mode
		ECO mode
		Holiday mode

RELATIVE HUMIDITY

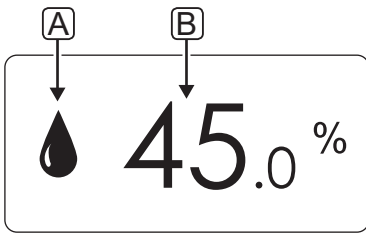

Pos.	Icon	Description
A		Relative humidity level
B	45.0	Relative humidity reading using two digital characters. Indicated with a “%” character

THERMOSTATS T-166 AND T-168

The figure shows all possible symbols and characters that can be shown on the display:

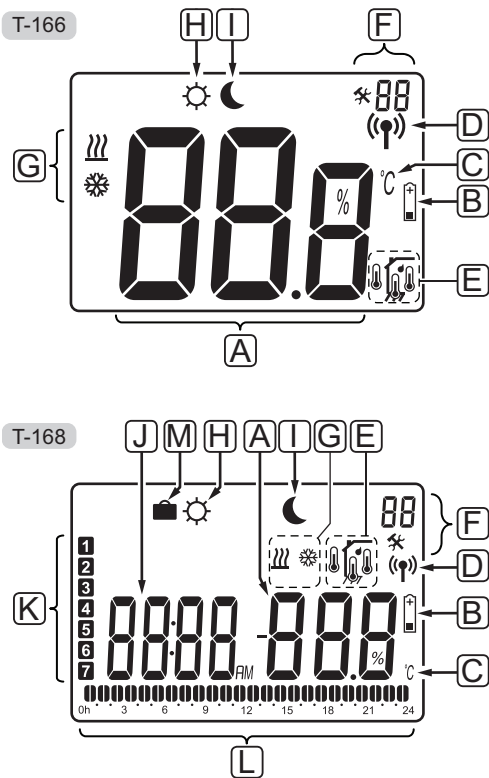

Pos.	Icon	Description
A		T-166 only Message field using three alphanumerical characters
		T-166 Temperature reading using a - or + sign, two digital characters, a decimal point and a character showing either 0 or 5
		T-168 Temperature reading using a - or + sign, two digital characters, a decimal point and a character showing either 0 or 5
		T-168 Relative humidity reading using two digital characters. Indicated with a “%” character
B		Low battery indicator
C		Temperature unit, shown when the character group A shows a temperature
D		Communication indicator
E		Indoor temperature indicator
		Remote sensor temperature indicator (RS mode) The text Err and a flashing sensor icon indicates a faulty sensor
		Indoor temperature with floor temperature limitation indicator The text Err and a flashing floor sensor icon indicates a faulty sensor
		Floor temperature indicator The text Err and a flashing floor sensor icon indicates a faulty sensor
		Outdoor temperature indicator The text Err and a flashing outdoor sensor icon indicates a faulty sensor
		T-168 only Relative humidity limit reached

Pos.	Icon	Description
F		Settings menu
		Settings menu number
G		Heating demand
		Cooling demand
H		Comfort mode
I		ECO mode
		Flashing icon in thermostat T-166 indicates activated holiday mode in the system.
J		<i>T-168 only</i> Digital clock
		<i>T-168 only</i> Parameter name in settings menu
		<i>T-168 only</i> Indicator showing AM or PM when the thermostat is set to 12 h mode
		No indication when the thermostat is set to 24 h mode
K		<i>T-168 only</i> Weekday selected/activated 1 = Monday 7 = Sunday
L		<i>T-168 only</i> Time selected or scheduled hour indicators, for Comfort mode, between 0:00 and 24:00
		Half = 30 minutes
		Full = 1 hour
M		Holiday mode

12.3 Operating buttons

The figure below shows buttons used to operate the digital thermostats.

T-169

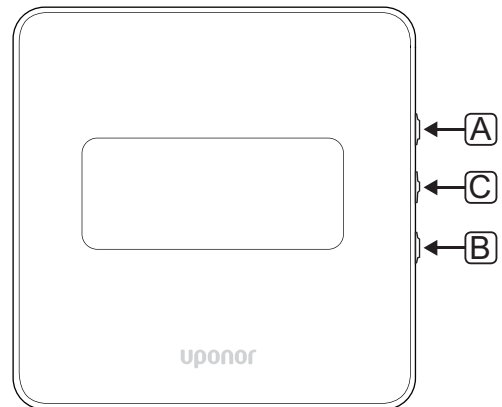

T-166
T-168

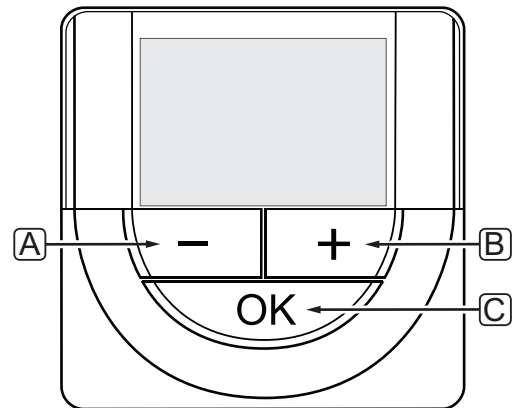

Pos.	Description
A	The - and + buttons are used to:
B	<ul style="list-style-type: none"> Adjust setpoint temperature Modify parameters in the settings menus
C	The OK button is used to: <ul style="list-style-type: none"> Toggle between current status data, and values of available sensors connected to the thermostat Enter and exit the settings menu Confirm a setting

12.4 Start up

When starting up, the software version is shown in the display for about three seconds. Then the thermostat enters run mode.

The first time the thermostat is started, or after a factory reset, the software requires the time and date to be set (T-168 only).

SOFTWARE VERSION

Current software version is displayed when the thermostat is powered on.

Examples:

T-169



T-166



T-168



SET TIME AND DATE (T-168 ONLY)

When starting the thermostat for the first time, after a factory reset, or after its been left without batteries too long, the software requires the time and date to be set.

Use buttons - or + to change the value, press the **OK** button to set the value and move to the next editable value.

! NOTE!

If no button is pressed for about 8 seconds, the current values will be saved and the software exits to run mode.

1. Set hours.



2. Set minutes.



3. Set 12 h or 24 h display of time.



4. Set day of the week (1 = Monday, 7 = Sunday).

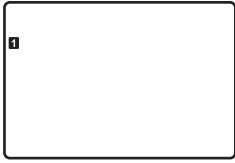

5. Set day of the month.



6. Set month.



7. Set year.



8. Press **OK** to return to run mode.

Date and time can also be set in the settings menu.

See section 12.9 Settings for more information.

12.5 Adjust temperature

The temperature is changed by adjusting the setpoint on the thermostat.

Use the buttons on the thermostat to adjust the temperature. The display will light up when pushing a button. It shuts off after about 10 seconds of inactivity.

The illustration below shows how to adjust the thermostat temperature setpoint.

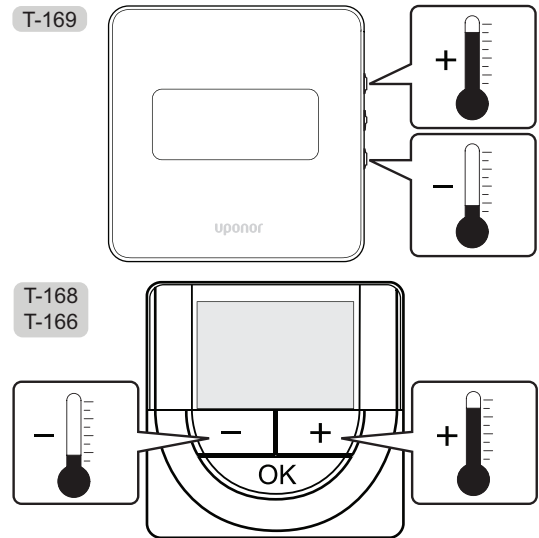

To adjust the thermostat temperature setpoint of the current control mode:

1. Press the - or + (T-169 = ▼ or ▲) button once.

The screen shows the current setpoint flashing.

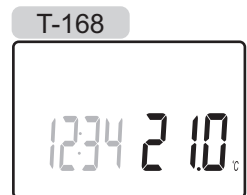
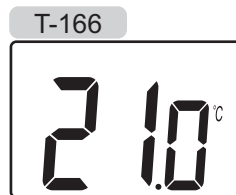
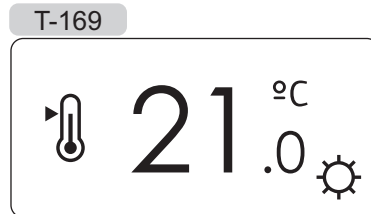

2. Press the - or + (T-169 = ▼ or ▲) button repeatedly to adjust the setpoint temperature. It will change with increments of 0.5.

When the new setpoint is set, the screen returns to run mode after a few seconds, showing the room temperature.

12.6 Run mode





During normal operation the thermostat is in run mode.

While in run mode the display shows specific control mode information.

12.7 Control mode

The thermostat has four different control modes, set in the settings menu.

Control modes:

T-169	T-166/ T-168	Description
	RT	Room temperature
	RFT	Room temperature with external floor sensor
	RS	Remote sensor
	RO	Room temperature with remote outdoor sensor

Different types of information can be shown in the display when in a control mode. The digital thermostat T-168 also shows the clock and scheduled program information.

Use the **OK** button to toggle between the information available.

RT, ROOM TEMPERATURE MODE

1. Room temperature (default)
2. Alarm list (only shown if an alarm is present in a T-169 thermostat)
3. Room temperature, current ECO/Comfort mode, and current heating/cooling demand (T-169 only)
4. Relative humidity (T-168 and T-169 only)

RFT, ROOM FLOOR TEMPERATURE MODE

1. Room temperature (default)
2. Alarm list (only shown if an alarm is present in a T-169 thermostat)
3. Floor temperature, current ECO/Comfort mode, and current heating/cooling demand (T-169 only)
4. Relative humidity T-168 and T-169 only)
5. Floor temperature (T-166 and T-168 only)

RS, REMOTE SENSOR MODE

1. Room temperature (default)
2. Alarm list (only shown if an alarm is present in a T-169 thermostat)
3. Remote sensor, current ECO/Comfort mode, and current heating/cooling demand (T-169 only)
4. Relative humidity (T-168 and T-169 only)

RO, REMOTE OUTDOOR SENSOR MODE

1. Room temperature (default)
2. Alarm list (only shown if an alarm is present in a T-169 thermostat)
3. Outdoor temperature, current ECO/Comfort mode, and current heating/cooling demand (T-169 only)
4. Relative humidity (T-168 and T-169 only)
5. Outdoor temperature (T-166 and T-168 only)

12.8 Change control mode

If an external sensor is connected to the thermostat, a control mode must be chosen to accommodate the extra functionality of the sensor.



NOTE!

If no button is pressed for about 8 seconds, while in a submenu, the current values will be saved and the software exits to the settings menu. About about 60 seconds later, it exits to run mode.

1. Press and hold the **OK** button until the settings icon and menu numbers is displayed in the top right corner of the display (about 3 seconds).
2. Use buttons - or + (T-169 = ▼ or ▲) to change the numbers to **04** and press **OK**.
3. Current control mode is displayed (RT, RFT, RS or RO).
4. Use buttons - or + (T-169 = ▼ or ▲) to change control mode (see list below) and press **OK**.

T-169	T-166/ T-168	Description
	RT	Room temperature
	RFT	Room temperature with external floor sensor
	RS	Remote sensor
	RO	Room temperature with remote outdoor sensor

5. Press and hold the **OK** button for about 3 seconds to exit the settings menu.

12.9 Settings

In this menu all settings regarding the operation of the thermostat is set.



NOTE!

As long as scheduling (program **00**) is activated (not set to **Off**) in a digital thermostat T-168, no other unit is allowed to change (override) the Comfort/ECO mode in that room.



NOTE!

If no button is pressed for about 8 seconds, while in a submenu, the current values will be saved and the software exits to the settings menu. About about 60 seconds later, it exits to run mode.

To enter the settings menu:

1. Press and hold the **OK** button for about 3 seconds.
2. The settings icon and menu numbers is displayed in the top right corner of the display.
3. Use buttons - or + (T-169 = ▼ or ▲) to change the numbers to locate a submenu (see list below).

00 = Program (T-168 only)

02 = Heating/cooling changeover*

03 = ECO mode setback temperature

04 = Control mode

05 = High floor temperature limitation

06 = Low floor temperature limitation

07 = Cooling allowed

08 = Display unit

09 = Climatic controller integration

10 = Time and date (T-168 only)

11 = Room temperature calibration

12 = Invert screen (T-169 only)

* *This menu is not visible if the thermostat is registered to a controller.*

4. Press **OK** to enter parameter edit mode.
T-166 and T-168: the parameter starts flashing.
T-169: the menu number is underlined.
5. Change parameters in the submenus.
6. Press and hold the **OK** button for about 3 seconds to exit the settings menu.

00 PROGRAM (T-168 ONLY)

In this menu, one of seven different scheduling programs for Comfort/ECO mode can be set. Program 1 to 6 is pre-programmed and the 7th is user defined. The scheduled programs show the day split into 30 minute intervals which is set to either Comfort (black marker) or ECO mode (blank marker).

This menu is not visible if an interface is connected to the system. Settings are referred to an interface (optional).

Program Off (default):

Room is set in Comfort mode. If a timer is available in the system, the room will use those set schedules but the thermostats own **ECO mode setback temperature.**

Program P1:

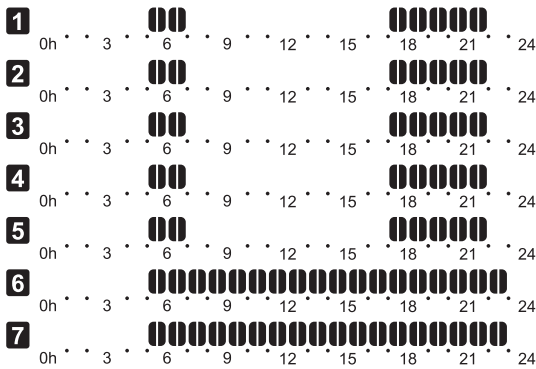

Program P2:

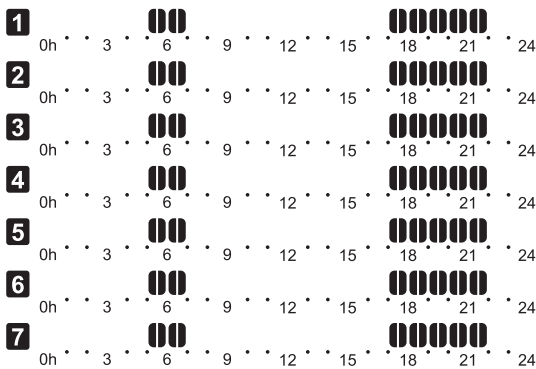

Program P3:

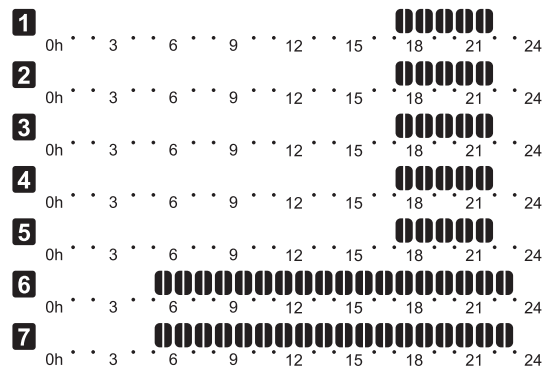

Program P4:

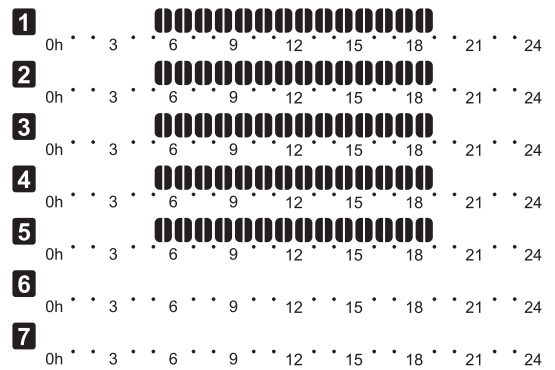

Program P5:

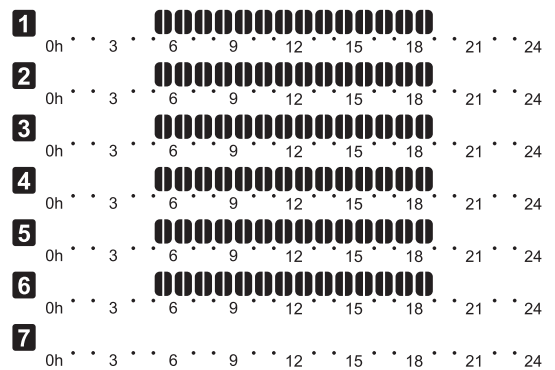

Program P6:

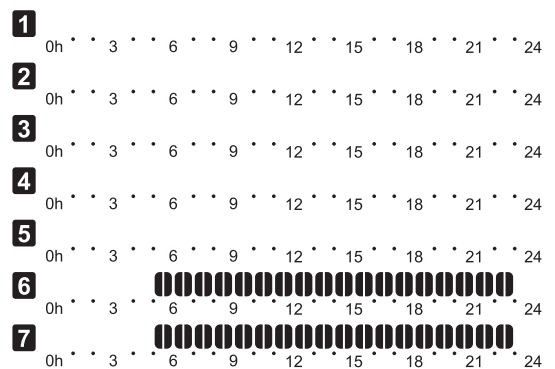

Select scheduling program

To select a scheduling program:

1. Press **OK** to enter parameter edit mode.
2. Use buttons - or + to select program.
Select between: **P1–P6**, **U** (user defined program) and **Off**.
3. Press **OK** to confirm program selection and return to the settings menu.

Customise user defined program for a single day

To customise the user defined program:

1. Press **OK** to enter parameter edit mode.
2. Use buttons - or + to select program **U**.
3. Press **OK** to confirm program selection.
The current day starts flashing.
4. Use buttons - or + to select a day.
5. Press and hold **OK** until **00:00** appears on the display (takes about 2 seconds).
6. Press **OK** to switch the marked interval between Comfort (☀) and ECO mode (☾).
7. Use buttons - or + to move the marker (at the bottom of the display). When moving the marker from one interval to another save the selected mode to that interval.
8. Repeat steps 6 and 7 until the display shows **23:30**.
9. Press + to finalize the current day and the software exits to the settings menu.
10. Repeat from step 1 to customise another day.

Customise user defined program for a full week

NOTE! This method resets the current user defined program to factory defaults.

To customise the user defined program:

1. Press **OK** to enter parameter edit mode.
2. Use buttons - or + to select program **U**.
3. Press and hold **OK** until day **1** and **00:00** appears on the display.
6. Press **OK** to switch the marked interval between Comfort (☀) and ECO mode (☾).
7. Use buttons - or + to move the marker (at the bottom of the display). When moving the marker from one interval to another save the selected mode to that interval.
8. Repeat steps 6 and 7 until the display shows **23:30**.
9. Press + to finalize programming the current day.
The text **Copy Yes** appears (Yes is flashing).
10. Use buttons - or + to select **Yes** or **No** and press **OK** to confirm.
Select **Yes** to copy the setting of the current day to the next. Repeat for every day that should be identical.
Select **No** and press **OK** to create a new scheduling interval for the following day. Then repeat steps 6 through 10 until the whole week is programmed.
11. The display returns to the settings menu when the final day is done.

02 HEATING/COOLING CHANGEOVER

This menu is not visible if the thermostat is registered to a controller. Heating/cooling changeover will be controlled by a physical heating/cooling switch or in the interface (optional), if connected.

03 ECO MODE SETBACK TEMPERATURE

In this menu the setback temperature for whenever the channel is in ECO mode is set.

The setting adjusts the current setpoint with the set value. In heating mode the setpoint is reduced, and in cooling mode it is increased.

If the setback temperature is set to 0, the thermostat will remain unaffected if a program sets the system in ECO mode.

This menu is not visible if an interface (optional) is connected to the system. The setting is then available in an interface.

To change this setting:

1. Press **OK** to enter parameter edit mode.
2. Use buttons - or + (T-169 = ▼ or ▲) to change the parameter.
Default: 4 °C
Setting range: 0 – 11 °C, 0.5 °C increments
3. Press **OK** to confirm the change and to return to the settings menu.

04 CONTROL MODE





In this menu control mode for the thermostat is set.

If an external sensor is connected to the thermostat, a control mode must be chosen to accommodate the extra functionality of the sensor.

Current control mode is displayed (RT, RFT, RS or RO).

To change this setting:

1. Press **OK** to enter parameter edit mode.
2. Use buttons - or + (T-169 = ▼ or ▲) to change control mode (see list below).

T-169	T-166/ T-168	Description
	RT	Room temperature
	RFT	Room temperature with external floor sensor
	RS	Remote sensor
	RO	Room temperature with remote outdoor sensor

3. Press **OK** to confirm the change and return to the settings menu.

05 HIGH FLOOR TEMPERATURE LIMITATION

In this menu a limit on the maximum allowable floor temperature is set.

This menu is only visible if control mode RFT is activated in settings menu 04. For systems with an interface (optional) this menu only shows the set value, changes are done in the interface.

To change this setting:

1. Press **OK** to enter parameter edit mode.
2. Use buttons - or + (T-169 = ▼ or ▲) to change the parameter.

Default: 26 °C

Setting range: 20 – 35 °C, 0.5 °C increments

NOTE!

This parameter cannot be set lower than the set value in settings menu **06 Low floor** temperature limitation.

3. Press **OK** to confirm the change and return to the settings menu.

06 LOW FLOOR TEMPERATURE LIMITATION

In this menu a limit on the minimum allowable floor temperature is set.

This menu is only visible if control mode RFT is activated in settings menu 04. For systems with an interface (optional) this menu only shows the set value, changes are done in the interface.

To change this setting:

1. Press **OK** to enter parameter edit mode.
2. Use buttons - or + (T-169 = ▼ or ▲) to change the parameter.

Default: 20 °C

Setting range: 10 – 30 °C, 0.5 °C increments



NOTE!

If this parameter is set lower than 16 °C the cooling icon will start flashing, warning for risk of condensation in the system.



NOTE!

This parameter cannot be set higher than the set value in settings menu **05 High floor** temperature limitation.

3. Press **OK** to confirm the change and return to the settings menu.

07 COOLING ALLOWED

In this menu it is set whether cooling is allowed in the room or not.

This menu is not visible if an interface (optional) is connected to the system. The settings are then available in the interface.

To change this setting:

1. Press **OK** to enter parameter edit mode.
2. Use buttons - or + (T-169 = ▼ or ▲) to toggle between **Yes** and **No**.

T-169	T-166/ T-168	Description
	Yes	Shows the cooling demand icon
	No	Hides the cooling demand icon

3. Press **OK** to confirm the change and return to the settings menu.

08 DISPLAY UNIT

In this menu temperature display unit is set.

To change this setting:

1. Press **OK** to enter parameter edit mode.
2. Use buttons - or + (T-169 = ▼ or ▲) to toggle between Celsius and Fahrenheit.

T-169	T-166/ T-168	Description
	DEg °C	Degrees Celsius
	DEg °F	Degrees Fahrenheit

3. Press **OK** to confirm the change and return to the settings menu.

09 CLIMATIC CONTROLLER INTEGRATION

In this menu it is set whether the thermostat also should be integrated, and share temperature data, with an Uponor Smatrix Move controller.

This menu can also be used when registering the thermostat to a relay module. Using the relay module to control distributed manifolds.

Default value: **no**

To change this setting:

1. Press **OK** to enter parameter edit mode.
2. Use buttons - or + (T-169 = ▼ or ▲) to toggle between **no**, **YEs** and **CnF**.

T-169	T-166/ T-168	Description
	no	Not integrated
	YEs	Integrated (requires to be registered with the Move controller first)
	CnF	Register with the Move controller/relay module, confirm on the Move controller/relay module

3. Press **OK** to confirm the change and return to the settings menu.

10 TIME AND DATE (T-168 ONLY)

In this menu time and date is set. This setting is required to utilise scheduling programs for this thermostat.

If an interface, a timer, or another digital thermostat T-168 (with a lower channel number) is registered to the controller, they will push the set time and date to the thermostat. Then only the 12/24 h setting is available.

Use buttons - or + to change the value. Press the **OK** button to set the value and move to the next editable value.

To change this setting:

1. Press **OK** to enter parameter edit mode.
2. Set hours.
3. Set minutes.
4. Set 12 h or 24 h display of time.
5. Set day of the week (1 = Monday, 7 = Sunday).
6. Set day of the month.
7. Set month.
8. Set year.
9. Press **OK** to confirm change and return to the settings menu.

11 ROOM TEMPERATURE CALIBRATION

In this menu the room temperature shown in the thermostat display can be calibrated.

To change this setting:

1. Press **OK** to enter parameter edit mode.
2. Use buttons - or + (T-169 = ▼ or ▲) to change the parameter.
Default: 0.0 °C
Setting range: -6.0 – 6.0 °C, 0.1 °C increments
3. Press **OK** to confirm the change and return to the settings menu.

12 INVERT SCREEN (T-169 ONLY)

In this menu the colour in the display can be inverted.

To change this setting:

1. Press **OK** to enter parameter edit mode.
2. Use buttons ▼ or ▲ to change the screen setting.
3. Press **OK** to confirm the change and return to the settings menu.

12.10 Replace batteries

THERMOSTATS T-166 AND T-168

Replace the batteries of the thermostat when the low battery icon  is shown in the display.

The illustration below shows how to replace the batteries.

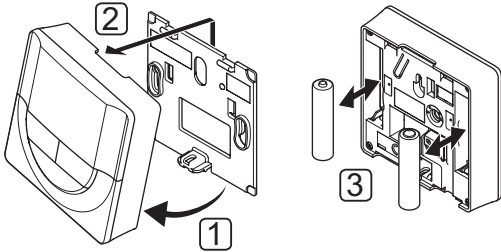

To replace the batteries:

1. Angle the thermostat from the bracket.
2. Remove it from the wall.
3. Replace batteries.

THERMOSTAT T-169

Replace the battery of the thermostat when the low battery icon  is shown in the display (alarm list).

The illustration below shows how to replace the battery.

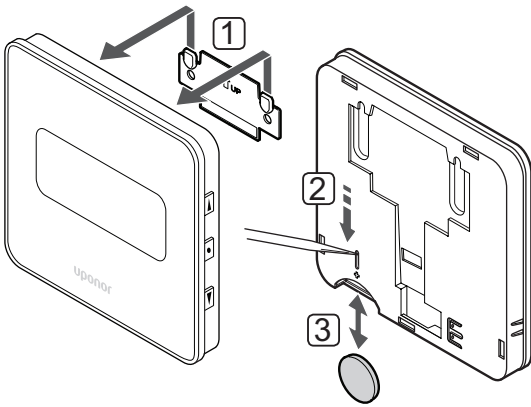

To replace the battery:

1. Remove the thermostat from the wall.
2. Use a pointed object to remove the battery.
3. Replace the battery.

12.11 Factory reset

Factory reset sets all parameter values to default settings.



NOTE!

Do not factory reset the thermostat if not absolutely needed.



NOTE!

A factory reset removes the registration data from the thermostat.

THERMOSTATS T-166 AND T-168

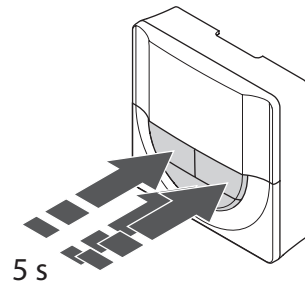

To factory reset the thermostat:

1. Press and hold the -, + and **OK** buttons for about 5 seconds until the screen goes blank.
2. The thermostat is now reset to factory default.

THERMOSTAT T-169

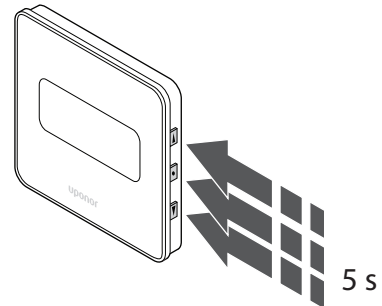

To factory reset the thermostat:

1. Press and hold the ▼, ▲ and **OK** buttons for about 5 seconds until the screen goes blank.
2. The thermostat is now reset to factory default.

13 Operate Uponor Smatrix Wave thermostatic head

The thermostatic head provides an option to control the temperature in a room using radiators. It has a display relaying information to the user and buttons for control.

Thermostatic heads:



Uponor Smatrix Wave T-162
(thermostatic head T-162)

13.1 Thermostat layout

The illustration below shows the parts of the thermostat.

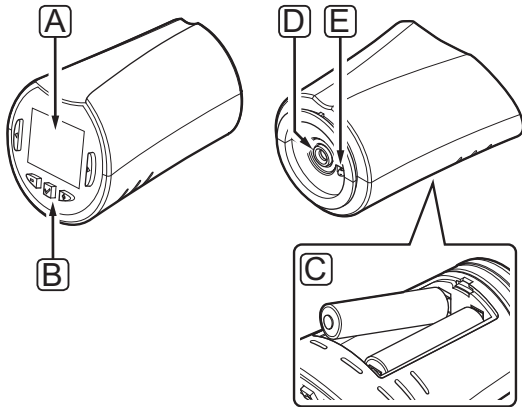

Item	Description
A	Display
B	Buttons
C	Batteries
D	Actuator
E	Temperature sensor (not used)

13.2 Display layout

The figure below shows all possible symbols and characters that can be shown on the display:

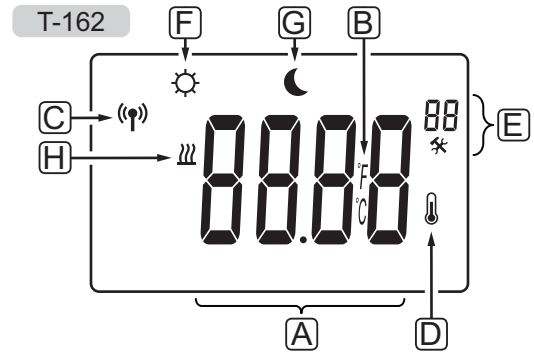

Pos.	Icon	Description
A		Message field using three alphanumeric characters
		Temperature reading from thermostat using a - or + sign, three digital characters and a decimal point
B		Temperature unit, shown when the character group A shows a temperature
C		Communication indicator
D		Indoor temperature indicator
		Sensor data received from thermostat
E		Settings menu
		Settings menu number
F		Heating mode
G		Comfort mode
H		ECO mode

13.3 Operating buttons

The figure below shows buttons used to operate the digital thermostats.

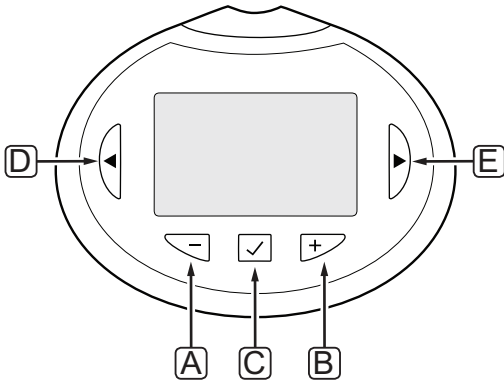

Pos.	Description
A	The - and + buttons are used to:
B	<ul style="list-style-type: none"> Adjust setpoint temperature Modify parameters in the settings menu
C	The OK button is used to: <ul style="list-style-type: none"> Enter and exit the settings menu Confirm a setting
D	The < and > buttons are used to:
E	<ul style="list-style-type: none"> Select settings menu Show available information while in run mode

13.4 Start up

When starting up, the software version is shown in the display for about three seconds. Then the thermostatic head enters run mode.

SOFTWARE VERSION

Current software version is displayed when the thermostat is powered on.

Example:

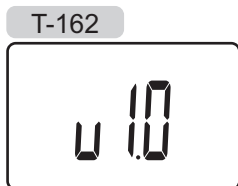

13.5 Adjust temperature

The room temperature setpoint is primarily adjusted using a room thermostat.

If the thermostatic head is installed in a room without a registered room thermostat the temperature setpoint is adjusted on the thermostatic head.

Use the - or + buttons on the thermostatic head to adjust the temperature. The display will light up when pushing a button. It shuts off after about 10 seconds of inactivity.

The illustration below shows how to adjust the thermostatic head temperature setpoint.

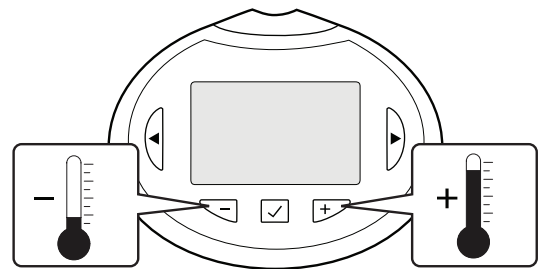

To adjust the temperature setpoint of the current control mode on the thermostatic head:

1. Press the - or + button once.

The screen shows the current setpoint flashing.

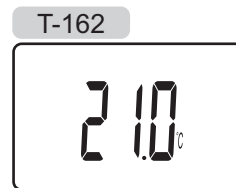

2. Press the - or + button repeatedly to adjust the setpoint temperature. It will change with increments of 0.5.

When the new setpoint is set, the screen returns to run mode after a few seconds, showing the room temperature.

13.6 Run mode

During normal operation the thermostatic head is set in run mode and the current room temperature is displayed.

13.7 Settings

In this menu all settings regarding the operation of the thermostatic head is set.



NOTE!

If no button is pressed for about 8 seconds, while in a menu, the current values will be saved and the software exits to run mode.

To enter the settings menu:

1. Press and hold the **OK** button for about 3 seconds.
2. The settings icon and menu numbers is displayed in the top right corner of the display.
3. Use buttons - or + to change the numbers to locate a submenu (see list below) and press **OK**.

08 = Display unit

4. Change parameters in the submenus.
5. Press and hold the **OK** button for about 3 seconds to exit the settings menu.

08 DISPLAY UNIT

In this menu temperature display unit is set.

To change this setting:

1. Press **OK** and the parameter starts flashing.
2. Use buttons - or + to toggle between Celsius and Fahrenheit.
 - DEg °C** – degrees Celsius
 - DEg °F** – degrees Fahrenheit
3. Press **OK** to confirm the change and return to the settings menu.

13.8 Replace batteries

Replace the batteries of the thermostat when the text **bAt** is shown in the display.

T-162



The illustration below shows how to change batteries.

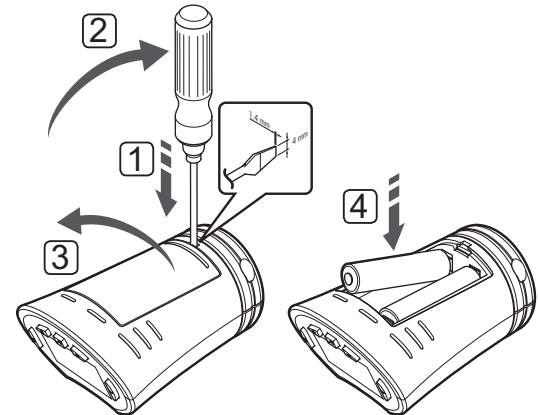

1. Insert a flat head screw driver in the slot by the lid, on the under side of the thermostatic head.
2. Gently pry the battery lid open with the screw driver.
3. Remove the battery lid.
4. Replace the batteries.

13.9 Factory reset

Factory reset sets all parameter values to default settings.



NOTE!

Do not factory reset the thermostatic head if not absolutely needed.



NOTE!

A factory reset removes the registration data from the thermostatic head.

1. Press and hold the -, + and **OK** buttons for about 10 seconds until the screen goes blank.
2. The thermostatic head is now reset to factory default.

14 Operate Uponor Smatrix Wave interface

The interface provides a centralised management of the Uponor Smatrix Wave system with continuous information updates and access to system settings.

Interface:



Uponor Smatrix Wave I-167 (interface I-167)

The illustration below shows the exterior of the interface.

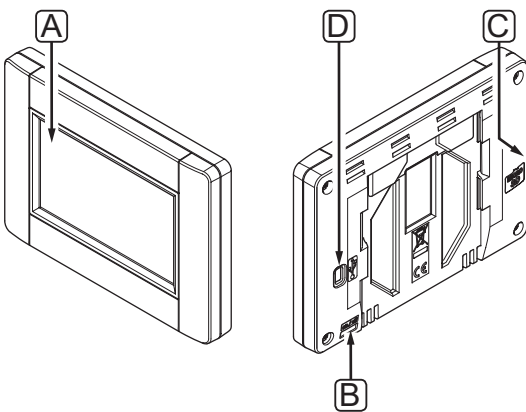

Pos.	Description
A	Screen
B	Power switch
C	MicroSD card slot
D	Mini USB connection

14.1 Touch screen

The interface has a touch screen as the main form of communication with the system.

The graphical user interface consists of large icons and buttons which adds to the user friendliness of the system.

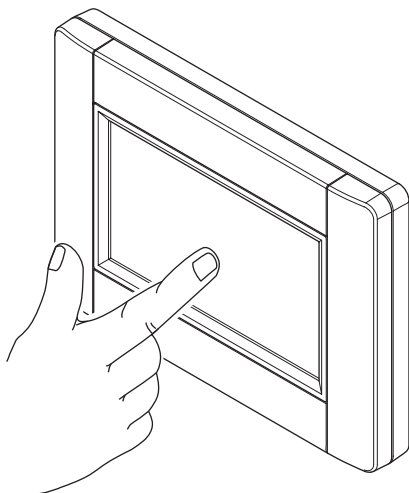

14.2 Home screen

The home screen is the base of the menu system in the interface. Here basic information of the system is displayed and buttons to venture further into the menu system is available.

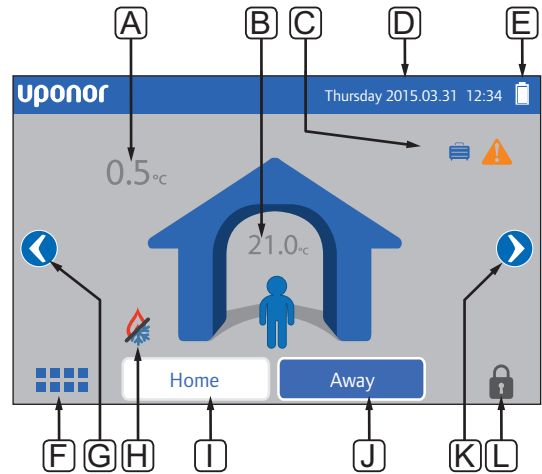











Pos.	Description
A	Outdoor temperature (requires outdoor temperature sensor)
B	Indoor temperature
C	Notifications
D	Date and time
E	Battery power indicator
F	Main menu
G	Left button, go to the last room menu
H	Heating/cooling mode indication
I	Home button, activates Comfort mode
J	Away button, activates ECO mode
K	Right button, go to the first room menu
L	Screen lock

14.3 Navigating the menu system

The menu system is navigated by the touch screen and is put together with a basic set of menu types.

General navigation buttons

Icon	Description
	Go to home menu
	Go back/cancel changes (if not saved)
	Scroll up and down in lists
	Scroll sideways or change sub menu (if available) The icon is grey if the option is not available
	Cancel settings and return to previous menu
	Move to the previous field
	Decrease value
	Increase value
	Move to the next field
	Confirm settings and return to previous menu or continue to next step in startup guide
	Settings Appears in some menus where more specific settings are available for a parameter

ICON GRID

The top most menu use icons for navigation. Press an icon to enter a submenu to change specific settings.

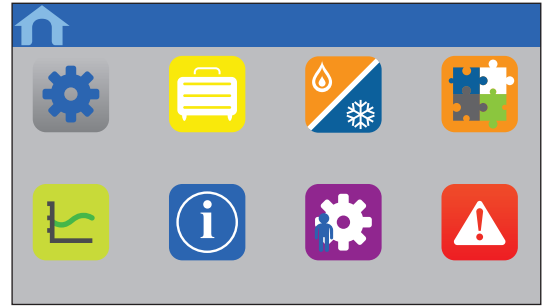

SETTINGS LIST

Most submenus have a list of available settings. Press the blue button for a setting to activate, select or set a parameter.

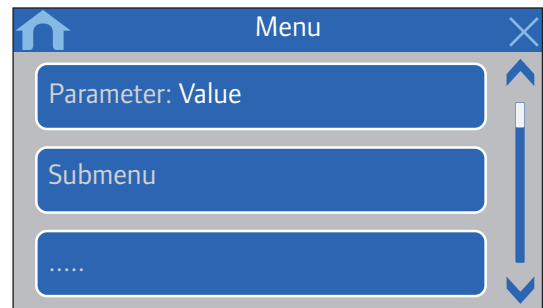

SELECT PARAMETER

Change the setting by pressing one of the parameter buttons. Blue button illustrates the chosen and/or previously saved parameter. White buttons illustrate available choices.

Save the parameter with the green check mark or cancel and revert to previous setting with the red X.

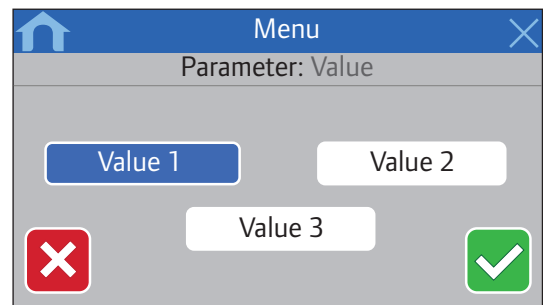

SET PARAMETER

Use the arrow buttons, < and >, to move the marker between characters and use buttons - or + to change the previously set value.

Save the parameter with the green check mark or cancel and revert to previous setting with the red X.

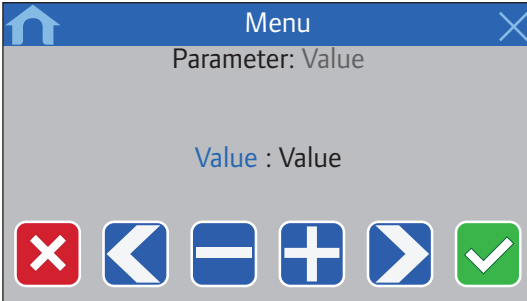

ACTIVATION LIST

Activate or deactivate settings from a list by pressing on the blue button next to the parameter name.

Activated parameter is illustrated with a green check mark, deactivated with a red X.

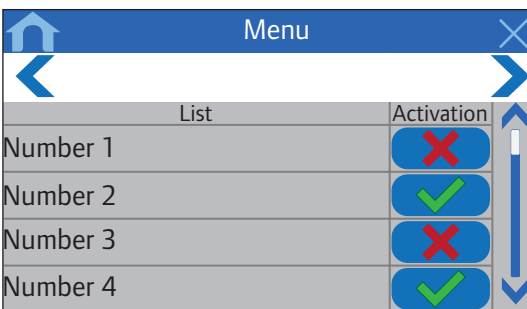

14.4 Adjust temperature

With the interface the room temperature of every room in the system can be monitored and adjusted.

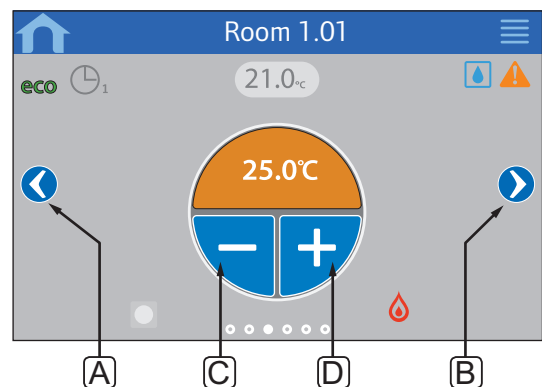
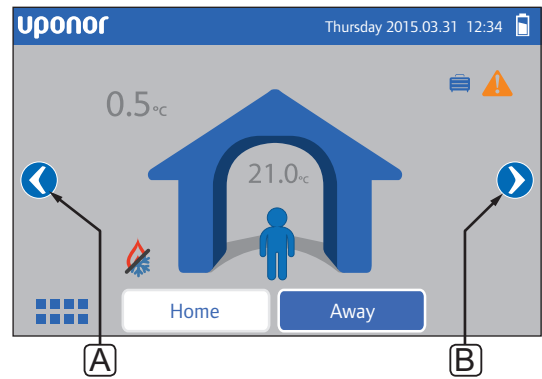

To adjust the temperature in a room:

1. Start from the home screen.
2. Press the left or right arrow (A or B) until the right room menu is displayed.
3. Use buttons - or + (C and D) to adjust the setpoint temperature of the room. If **Thermostat override** (available in **Room settings**) is not allowed, a grey area is showed instead, and setpoint cannot be changed from the interface.

14.5 Room information

In this menu the setpoint for every room can be adjusted without the need to be at the affected thermostat.

Advanced information and settings are available in submenus.

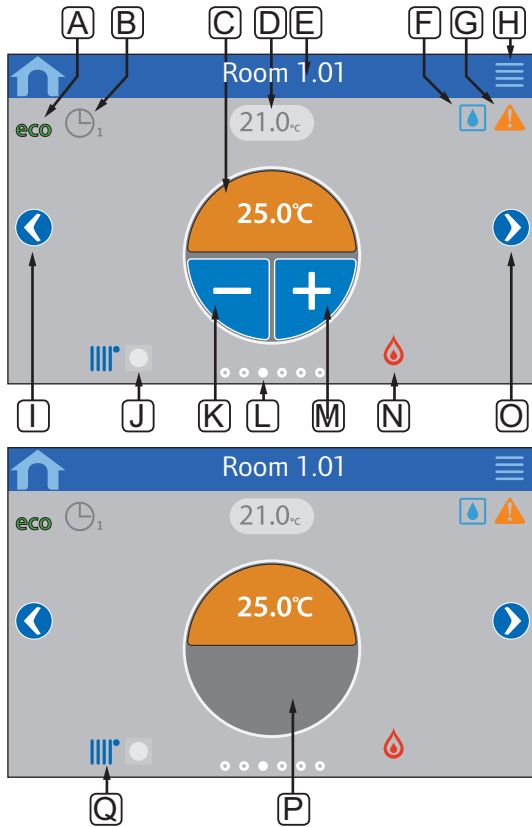

Pos.	Description
A	ECO mode activated
B	Scheduling activated, number indicates which program
C	Setpoint temperature The background colour changes if the system is in heating (orange) or cooling mode (blue)
D	Current room temperature
E	Current room name (editable in room settings)
F	Relative humidity limit reached*
G	Active alarms in alarm menu
H	Advanced room information menu button, room status, room settings, and room name
I	Left button, go to the preceding room menu
J	Remote thermostat indication - Blue if receiving setpoint from dial or public thermostat - Grey if dial or public thermostat is overridden by interface - Hidden if there is no dial or public thermostat in use in the current room
K	Decrease setpoint temperature
L	Current room menu indication
M	Increase setpoint temperature
N	Heating/cooling mode indication*
O	Right button, go to the next room menu
P	The grey area indicates if the room is using an analog thermostat, with Thermostat override in the Room settings menu not allowed
Q	Thermostatic head indication. Shown if a thermostatic head is present in the room.

* Not shown in rooms with a thermostatic head

ROOM STATUS

This menu shows advanced information not available in the room information menu. It is accessible by pressing button **H** in the room information menu.

Information shown in the menu:

- Current room name
- Controller channels registered to the current room
- ECO mode setback temperature
- Floor sensor, if installed
- Battery status
- Radio status
- Room demand, active or inactive
- Actuator status*, opened or not
- Current operating mode*, heating or cooling
- Room cooling*, enabled or disabled
- Bypass information*
- Relative humidity sensor value*
- Relative humidity control*, activated or not
- Relative humidity setpoint*
- Number of thermostatic heads registered to the current room

* Not shown in rooms with a thermostatic head

ROOM SETTINGS

In this menu advanced settings on a room by room basis can be changed. It is accessible by pressing button **H** in the room information menu.

Cooling

Default: Allowed

Setting range: Allowed, Not allowed

Set whether cooling is allowed in the room or not.



NOTE!

This setting is not available for rooms with a thermal head.

ECO setback

Default: 4.0 °C

Setting range: 0.0 – 11.0 °C, 0.5 °C increments

Set the setback temperature for when entering ECO mode in a room.

The setting adjusts the current setpoint with the set value. In heating mode the setpoint is reduced and in cooling mode it is increased.

If the setback is set to 0, the thermostat will remain unaffected if a program sets the system in ECO mode.

ECO profiles

Set, change or view current ECO profile schedules for the current room.

See section 14.15 ECO profiles for more information.

Max setpoint

Default: 35.0 °C

Setting range: min setpoint – 35.0 °C, 0.5 °C increments

Set the maximum available setpoint temperature for the thermostat in the room.

This setting limits the thermostat placed in the room.

Min setpoint

Default: 5.0 °C

Setting range: 5.0 °C – max setpoint, 0.5 °C increments

Set the minimum available setpoint temperature for the thermostat in the room.

This setting limits the thermostat placed in the room.

Floor temp limit max

Default: 26.0 °C

Setting range: min floor temp limit – 35.0 °C, 0.5 °C increments

This setting is only available if a floor sensor is installed.

Set the maximum floor temperature limit, if a floor sensor is available in the room and the thermostat is set in RFT control mode.

Floor temp limit min

Default: 20.0 °C

Setting range: 5.0 °C – max floor temp limit, 0.5 °C increments

This setting is only available if a floor sensor is installed.

Set the minimum floor temperature limit, if the thermostat is set in RFT control mode.

Comfort setting

Default: Inactive

Setting range: Inactive, 5 – 12%, 1% increments

Set basic level of comfort for the room when there is no demand for heating. It will shorten the heat up time for the room, which is useful in rooms where other heating sources, e.g. a fireplace, is present. The value is a percentage of time the actuators are opened.



NOTE!

This setting is not available for rooms with a thermal head.

Thermostat override

Default: No

Setting range: Yes, No

Set whether the interface is allowed to override and manage the setpoint for analog thermostats.



NOTE!

This setting is not available for rooms with a thermal head.

Room used for average calculation

Default: Yes

Setting range: Yes, No

Set whether the current room is to be used to calculate average temperatures for the whole system. This value is only used to display a value and does not affect the operation of the system.

ROOM NAME

Set a name for the room. This name will be used to identify the room in the interface.

14.6 Main menu

The main menu is the top most menu and it uses icons for navigation. Press an icon to enter a submenu to change specific settings.

Menu tree

Main menu

System settings	
	General ECO setback
	System ECO profiles
	Valve/pump exercise
	Supply diagnostic
	Autobalance
	Room check
	Room bypass
	SD card
	Ceiling cooling settings
Holiday	
Heating/Cooling	
	Cooling offset*
	Operating mode*
Integration	
	Controller relay
	General purpose input (GPI)
	Relay output module
	Heat pump integration
Trends	
Alarms	
Preferences	
	Language
	Display
	Regional settings
	RF Link
	Date & Time
	Factory reset
System info	

* Only visible if cooling is available in Heating/Cooling menu

14.7 System settings

In this menu, system specific settings can be changed.

GENERAL ECO SETBACK

Default: 4.0 °C

Setting range: 0.0 – 11.0 °C, 0.5 °C increments

Set a general ECO setback value that will be used to change the room setpoint temperature for all thermostats when in ECO mode. It will lower the setpoint in heating mode and raise the setpoint in cooling mode.



NOTE!

Changing this value will reset any individual room setback values already set and the new value will be transmitted to the thermostats.

System ECO profiles

Set, change or view current ECO profile schedules for the whole system.

See section 14.15 ECO profiles for more information.



NOTE!

Setting an ECO profile on a system wide level will overwrite any existing ECO profiles set/created for all rooms in the system.

VALVE/PUMP EXERCISE

Default: Valve and pump

Setting range: Inactive, Valve only, Valve and pump

Set exercise mode once a week during periods of low activity for the valves and/or pumps to avoid them getting stuck.

If activated, a day and time can be set.

SUPPLY DIAGNOSTIC

Default: Inactive

Setting range: Active, Inactive

Activate a function checking whether the supply temperatures are too high or too low. The result is displayed after roughly 24 hours. If needed, information on how to optimise the system is also displayed.

AUTOBALANCE

Default: Active

Setting range: Active, Inactive

Activate the autobalance function.

See section 3.5 Functions > Autobalance for more information.

ROOM CHECK

This is a diagnostic function detecting whether a room thermostat is installed in the right room.

The room check can be stopped any time by choosing **Inactive** in **Room check: Active**.

1. Set start time (preferably during the night).
Default: 22:00
2. Set end time (preferably during the night).
Default: 07:00
3. Set how much to increase the current setpoint value, for checking purposes.
Default: 1.0 °C
Setting range: 0.0 – 5.5 °C, 0.1 °C increments
4. Set how much to decrease the current setpoint value, for checking purposes.
Default: 0.5 °C
Setting range: 0.0 – 5.5 °C, 0.1 °C increments
5. Enter the room list and select which rooms to check.

The function will check one thermostat per 24 hours.
6. Go back to the room check menu and select **Active** in **Room check: Inactive**.

The result is shown in **Room check results** when the room check has run its course.

 = OK

 = Not OK

 = Not checked

ROOM BYPASS

Select a maximum of up to two rooms, for each controller, to act as a bypass in the system.

The bypass ensures that the actuators for these rooms are opened when there is no heating demand to maintain a minimum flow in the system.

Use rooms with a high heating demand (the coldest rooms) to avoid too high temperatures in rooms with low heating demands.



NOTE!

This setting is not available for rooms with a thermal head.

RH CONTROL

General RH setpoint:

Default: 75%

Setting range: 0 – 100%, 1% increments

Deadzone (hysteresis):

Default: 5%

Setting range: 0 – 50%, 1% increments

Room RH Setpoint:

Default: 75%

Setting range: 0 – 100%, 1% increments

Set the general relative humidity setpoint and humidity deadzone (hysteresis). The setpoint shuts off cooling when the limit is reached and the hysteresis decides when the system is allowed to start cooling again.

The controller list displays rooms with a relative humidity (RH) sensor, for each controller if more than one. It is possible to activate RH control (✓ to activate, ✗ to deactivate), set individual room RH setpoints and select a dehumidifier if it is present in a room.

These settings are only available if cooling is allowed and a RH sensor is installed in the system.

SD CARD

Use a microSD card to clone interface settings or update the software in the interface.

See section 14.16 MicroSD card for more information.



CAUTION!

Do not remove the microSD card while updating.

CEILING COOLING SETTINGS

Set if a registered channel produces ceiling cooling (if available) or underfloor heating/cooling, for each controller if more than one.

These settings are only applicable if 4-pipe heating/cooling is installed in the system.



NOTE!

This setting is not available for rooms with a thermal head.

14.8 Holiday

When away on holiday, the system can be programmed in advance to reduce the system energy need by adjusting the setpoint while away.

Set **Enable Holiday mode** to **Yes** to enable holiday mode during the set period. The holiday mode icon is displayed on the home screen during the set period.

Cancel Holiday mode by entering the Holiday menu again and press **Yes**, when asked **Cancel Holiday mode?**

This menu is not available when the system is in cooling mode.

START DATE

Default: Current time and date

Set a start date and time for the holiday.

END DATE

Default: 24 hours later than set start date

Set end date and time for the holiday.

HOLIDAY SETPOINT

Default: 17.0 °C

Setting range: 5.0 – 35.0 °C, 0.5 °C increments

Set an indoor temperature setpoint to be used during the holiday period.

ENABLE HOLIDAY MODE

Default: No

Setting range: Yes, No

Select **Yes** and confirm to enable holiday mode during the set period.

14.9 Heating/Cooling

In this menu, settings regarding switching between heating and cooling are made.

First select if cooling is available in the system. When answering **Yes** a settings menu appears. In the settings menu (⚙️) **Cooling offset** and **Operating mode** can be set.

COOLING OFFSET

Default: 2.0 °C

Setting range: 0.0 – 5.0 °C, 0.5 °C increments

Set the offset temperature for when to start cooling.

This value will be added to the current setpoint temperature (setpoint + cooling offset) if cooling is activated.

Cooling will start when the temperature in the room reaches setpoint + cooling offset.

OPERATING MODE

Default: H/C Slave

Setting range: H/C Master, H/C Slave (H/C input)

Select how the system decides how to switch between heating and cooling.

H/C Master lets the user (forced start) or the system (external sensor input) decide when to switch between heating and cooling. **H/C Slave** switch between heating and cooling with an external input signal (on/off) connected to either the controller or a thermostat. A settings icon (⚙️) appears if choosing **H/C Master**.

⚙️ H/C Master:

Default: Force Heating

Setting range: Force Cooling, Force Heating, H/C Sensor

Select to either force the system into cooling or heating, or to switch between cooling and heating with the help of an external sensor measuring the supply temperature.

H/C Sensor:

Switch limit, default: 18.0 °C

Switch limit, Setting range: 5.0 – 30.0 °C, 0.5 °C increments

Hysteresis, default: 4.0 °C

Hysteresis, Setting range: 1.0 – 10.0 °C, 0.5 °C increments

Set the limit and hysteresis at which supply temperature the system decides when to switch between heating and cooling.

14.10 Integration

This menu manages settings when integrating the system with other devices.

CONTROLLER RELAY

Default: Common pump, Individual pump

Setting range: Common pump, Individual pump

Set controller relay mode. This menu is only shown if several controllers are registered to the interface.

Individual pump:

Relay status is set on a controller basis. One pump per controller is connected. If there a demand in one room of the controllers, only the pump connected to that controller is started.

Common pump:

Relay status is set on a system wide basis. One pump per system is connected (to the master controller only). If there is a demand in one room of the controllers, the main pump is started.

When set to **Common**, controller specific settings are made available.

For each registered controller, except the master controller, the pump output relay can be set to either **H/C switch** or **Inactive** (default). Making the relay able to switch between heating and cooling or deactivating it for the time being.

GENERAL PURPOSE INPUT (GPI)

Default: Heating/Cooling switch

Setting range: Heating/Cooling switch, ECO/Comfort switch, General System Alarm

Set which kind of signal is to be received by the general purpose input.

RELAY OUTPUT MODULE

Default: Pump + H/C switch

Setting range: Pump + H/C switch, Pump + Dehumidifier, Boiler + chiller

Set the function of the registered relay output modules. Only registered relay output modules are visible.

HEAT PUMP INTEGRATION*Default: Inactive**Setting range: Active, Inactive*

This menu is hidden. To access the menu, press and hold the menu title "Integration" on top of the screen until this submenu appears.

This function is only available in selected countries, contact a local Uponor office for more information.

**CAUTION!**

If **Heat pump integration** is deactivated make sure that it also is deactivated in the heat pump. Otherwise it may affect the operation of the heat pump.

When activated, the system will provide the heat pump with temperature sensor data from Uponor system thermostats to adjust the supply temperature. Device integration specific settings also appears.

Dynamic heat curve:*Default: Inactive**Setting range: Active, Inactive*

Activates dynamic adjustment of the system heat curve.

Response:*Default: Slow**Setting range: Slow, Moderate, Fast*

Set the response speed of the system.

A slow system takes longer to reach the setpoint, a fast system is faster but might overshoot the setpoint, and a moderate system is somewhere in between.

Pulse input:*Default: Inactive**Setting range: Inactive, Active*

Activate pulse input on the controller.

Sensor values:

Activate the sensor values that should be sent to the heat pump for supply temperature calculations, select from a list.

14.11 Trends

This menu shows temperature and utilisation trends for the last 7 days, for up to 12 rooms at the time.

Select between showing:

- Curves showing average system temperature, average system setpoint temperature and outdoor temperature (if an outdoor sensor is installed).
- Curves showing indoor temperature and setpoint temperature for a room as well as outdoor temperature (if an outdoor sensor is installed).
- Bars showing a utilisation factor per room. The factor is the percentage of time when the actuator has been opened.

14.12 System info

This menu shows information about current software versions, the number of controllers connected and other interface specific information.

14.13 Preferences

In this menu, settings specific to the interface are made.

LANGUAGE

Select language. Current language is shown in the icon before entering the setting.

More languages than shown in the list can be added using the microSD card.

DISPLAY

Backlight:

Default: 80%

Setting range: 10 – 100%, 1% increments

Set backlight intensity

Return screen settings:

Default: House

Setting range: House, Alarms, Trends

Select which home screen to exit to, after about 3 minutes of inactivity.

Screen saver:

Default: Inactive

Setting range: Active, Inactive

Activate the screen saver. The screen will, after about 3 minutes of inactivity, exit to the home screen and dim the brightness to about 10%. It will brighten again when touched.

Switch off backlight during night?:

Default: No

Setting range: No, Yes

When activated the screen will, between 22:00 and 07:00, exit to the home screen and then shut it off after about 3 minutes of inactivity. It will start again when touched.

Screen lock:

Default: Inactive

Setting range: Active, Inactive

This function requires a microSD card when being activated. It can be removed afterwards if needed without affecting the function or PIN-code.

Activate the screen lock and set a PIN-code in the settings menu. The screen will revert to the home screen and lock after 3 minutes of inactivity. To unlock, press the lock-icon on the home screen and enter the set PIN-code. If an incorrect PIN-code is entered 3 times, instructions will appear on the screen on how to retrieve the PIN.

The PIN-code can be changed by accessing the settings menu once again and entering a new code.

The PIN-code is saved in a text-file (TS_Lock.txt) on the microSD card. It can be easily retrieved and viewed using a computer. Editing or deleting the text-file will not change or deactivate the PIN-code on the interface.

Screen cleaner:

The screen cleaner deactivates the touch screen for about 30 seconds, allowing the user to clean the screen without pushing any on-screen buttons.

REGIONAL SETTINGS

Set a time and date format, and temperature unit to use in the interface.

RF LINK

Register and/or unregister one or more controllers to the interface.

Link touchscreen to controller:

See section 8.5 Startup guide > Register the interface to a controller for more information.

Unlink touchscreen from interface:

Select the controller to be unregistered from the list, and confirm the choice by pressing the green checkmark.

Link Smart Home Gateway

Link an Smart Home Gateway to the controller.

See separate documentation for more information.

DATE & TIME

Set time and date for the system.

FACTORY RESET

Reset the interface to default values.

14.14 Alarms

This menu shows a list of current alarms in the system.

The list contains information about which kind of alarm it is (**Type**), where it is (**Rooms**) and when it occurred (**Time**).

Only the latest ten alarms are shown in this menu. Alarms older than these ten are deleted automatically, though all alarms is logged with a time stamp on the controller microSD card.

Alarms can be acknowledged and deleted (if remedied) individually or all at once.



= Acknowledge and delete alarm

14.15 ECO profiles (scheduling)

Set, change or view current ECO profile schedules for the current room or system.



NOTE!

Setting an ECO profile on a system wide level will overwrite any existing ECO profiles set/ created for all rooms in the system.

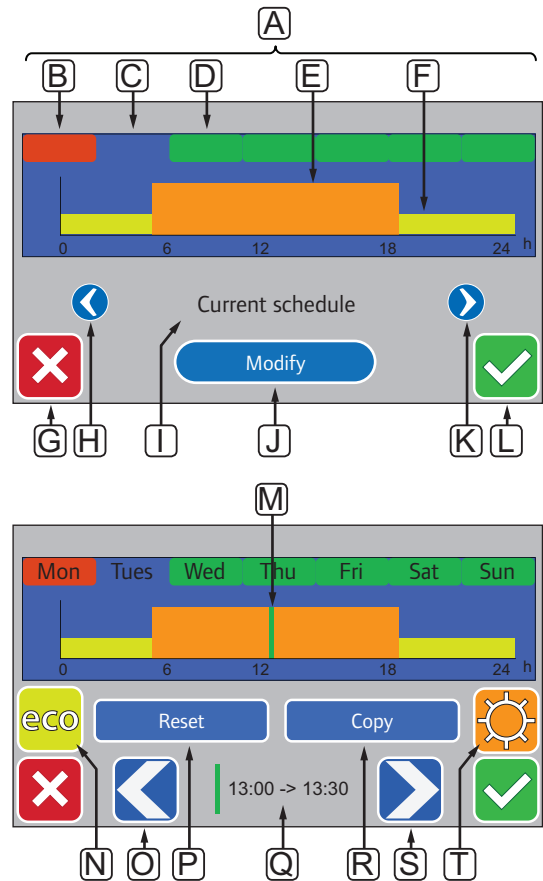

This illustration is an example showing most of the available graphics in this menu.

Pos.	Description
A	Weekdays, press one of the days to show or modify the schedule for that day
B	Weekday not yet programmed (Modify only)
C	Weekday selected for viewing or programming
D	Programmed weekday
E	Programmed Comfort mode
F	Programmed ECO mode
G	Cancel settings and go to previous menu
H	Scroll programmed schedules left
I	Programmed schedule name
J	Modify programmed schedule (only shown for Custom schedule)
K	Scroll programmed schedules right
L	Confirm changes and go to previous menu
M	Position of programming marker, 30 minute interval (Modify only)
N	Program ECO mode for marked 30 minute interval (Modify only)
O	Move marker left (Modify only)
P	Reset the custom schedule to default values (Modify only)
Q	Time of day for programming marker (Modify only)
R	Copy a schedule from other program (Modify only)
S	Move marker right (Modify only)
T	Program Comfort mode for marked 30 min interval (Modify only)

ACTIVATE A PROGRAMMED SCHEDULE

To select an ECO profile:

1. Go to the **ECO profile** menu.
 - 1.1 For a single room:
Home screen > Room information > Room settings > ECO profile.
 - 1.2 For the whole system:
Home screen > Main menu > System settings > ECO profile.
2. Use buttons < and > [**H** and **K**] to select a profile. The profile name is displayed at position **I**.
3. Confirm and save with the green check mark [**L**].

MODIFY CUSTOM PROFILE

To modify the custom ECO profile for a room:

1. Go to the **ECO profile** menu.
 - 1.1 For a single room:
Home screen > Room information > Room settings > ECO profile.
 - 1.2 For the whole system:
Home screen > Main menu > System settings > ECO profile.
2. Use buttons < and > [**H** and **K**] to select the **Custom** profile. The profile name is displayed at position **I**.
3. Press **Modify** [**J**].
4. Select (press) a weekday [**C**].
5. Use buttons < and > [**O** and **S**] to move the marker [**M**] to a the time of the day.
6. Press button **N** or **T** to set the selected 30 minute interval to ECO [**N**] or Comfort [**T**] mode. The marker moves automatically to the next 30 minute interval.

TIP! Press the button repeatedly to quickly set a large block of time.
7. Repeat step 5 and 6 until the selected weekday is set.
8. Repeat steps 4 to 7 until the whole week is set.
9. Confirm and save with the green check mark [**L**].

RESET THE CUSTOM PROFILE

To reset and start over with the custom ECO profile:

1. Go to the **ECO profile** menu.
 - 1.1 For a single room:

Home screen > Room information > Room settings > ECO profile.
 - 1.2 For the whole system:

Home screen > Main menu > System settings > ECO profile.
2. Use buttons < and > [**H** and **K**] to select the **Custom** profile. The profile name is displayed at position **I**.
3. Press **Modify** [**J**].
4. Press **Reset** [**P**].
5. Start modifying the custom profile.

CREATE A CUSTOM PROFILE WITH A COPY

To create a custom ECO profile using an existing profile created for another room:

1. Go to the **ECO profile** menu.
 - 1.1 For a single room:

Home screen > Room information > Room settings > ECO profile.
 - 1.2 For the whole system:

Home screen > Main menu > System settings > ECO profile.
2. Use buttons **H** and **K** until the **Custom** profile is selected. Profile name is displayed at position **I**.
3. Press **Modify** [**J**].
4. Press **Copy** [**R**].
5. Select the room from where to copy the custom profile.
6. Confirm and save with the green check mark [**L**].

14.16 MicroSD card

The microSD card have several purposes for the interface. It can be used to update the software in the interface, clone interface settings, or adding display languages.

UPDATE THE SOFTWARE



CAUTION!

Do not remove the microSD card while updating.

To update the software in the interface:

1. Download the software package from the Uponor website.
2. Eject the microSD card from the interface and insert it into a computer, use the supplied microSD to SD adapter if required.
3. Copy the downloaded file to the microSD card.

NOTE! Use "Safely Remove Hardware and Eject Media", to not cause harm the SD-card when removing it from the computer.
4. Insert the microSD card into the interface.
5. Go to the **SD card** menu, **Main menu > System settings > SD card**.
6. Press **Update with SD-card**.
7. Confirm that system settings can be changed during the process.
8. Wait until the counter in interface has reached 100%, the interface has restarted and the home screen is shown again.
9. The software update is now complete.

WRITE CLONED SETTINGS



CAUTION!

Do not remove the microSD card while writing cloned settings.

To write cloned settings to the microSD card:

1. Go to the **SD card** menu, **Main menu > System settings > SD card**.
2. Press **Write cloned settings**.
3. Confirm that any existing cloned settings on the microSD card will be lost and replaced with the ones from the interface.
4. Wait until the interface shows a screen informing that the cloned settings has been saved.
5. A clone of the settings on the interface has now been saved on the microSD card.

READ CLONED SETTINGS



CAUTION!

Do not remove the microSD card while reading cloned settings.

To read cloned settings to the interface:

1. Use a microSD card from an identical system.
2. Replace the existing microSD card in the interface with the new one.
3. Go to the **SD card** menu, **Main menu > System settings > SD card**.
4. Press **Read cloned settings**.
5. Confirm that any existing settings will be lost and replaced with the ones on the microSD card.
6. Wait until the interface has restarted and the home screen is shown again.
7. Replace the microSD card with the old one.
8. The cloning of settings is now complete.

ADD DISPLAY LANGUAGES

To add a new display language:

1. Insert a microSD card, containing the language packages (supplied with the interface), into the interface.
2. Go to the **Language** menu, **Main menu > Preferences > Language**.
3. Use buttons **<** or **>** to scroll between available language packages.
4. Select a new language and press the confirm button.

The current language package will be saved on the interface, overwriting the existing package, and the selected language will be set. The microSD card can be ejected without interfering with the language setting.

14.17 Factory reset of the interface



NOTE!

Do not factory reset the interface if not absolutely needed.



NOTE!

A factory reset removes the registration data from the interface.

To reset the interface to factory settings:

1. Go to the **Preferences** menu, **Main menu > Preferences**.
2. Press **Factory reset**.
3. Press and hold the confirm button to initiate factory reset. All existing settings will be lost and reset to factory default values.
4. Wait until the interface has restarted and the start up guide is shown.
5. The process of factory reset of the interface is now complete.

15 Maintenance

The maintenance of Uponor Smatrix Wave includes the following:

- Manual preventive maintenance
- Automatic preventive maintenance
- Corrective maintenance
- Controller LEDs

15.1 Manual preventive maintenance

Uponor Smatrix Wave requires no preventive maintenance except cleaning:

1. Use a dry soft cloth to clean the components.



WARNING!

Do not use any detergents to clean the Uponor Smatrix Wave components.

15.2 Automatic preventive maintenance

Uponor Smatrix Wave is equipped with an automatic exercise function. This function consists of a test run designed to prevent the pump and actuators from seizing up due to inactivity.

This exercise is run every 6 days \pm 24 hours at random:

- The pump exercise operates only if the pump has not been activated since the last exercise. The pump is activated for 3 minutes during the exercise.
- The actuator exercise operates only if the actuators have not been activated since the last exercise. The exercise consists of opening and completely closing the actuators periodically.

If the system includes an interface I-167, the exercise function can be used at any time.

15.3 Corrective maintenance

FALLBACK MODE

If a thermostat is malfunctioning or not detected, the controller executes the fallback mode to maintain the temperature in the room (heating mode only) until the problem is resolved.

RESETTING THE CONTROLLER

If the controller does not work as expected, for example due to a hang-up, it can be reset to solve the problem:

1. Disconnect and reconnect the controller to AC power.

15.4 Controller LEDs

If an interface I-167 is not connected to the system, it is recommended to occasionally check the power LED on the controller for alarms. The power LED flashes continuously for general alarms. Determine which thermostats are issuing alarms by removing the cover. If a channel LED is indicating an error, check the function and batteries of the registered thermostat.

The controller power LED is on during normal operation.

All the channel LEDs are off when there is no current or waiting actuator activity. The LEDs turn on when the corresponding actuators are activated or start flashing when they are awaiting activation.

Up to eight actuators in six rooms can be in the opening process at the same time. If a slave module is installed, the LEDs of the seventh and subsequent actuators flash while they are waiting for the previous actuators to be fully open.

The illustration below shows the position of the controller LEDs.

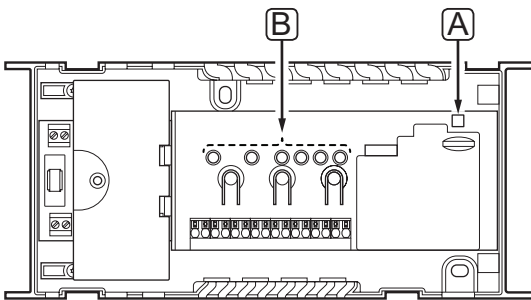

Item	Description
A	Power LED
B	Channel LEDs

The table below describes the status of the controller LEDs.

LED	Status
Power	<p>The controller power LED is always on and flashes when a problem occurs, such as:</p> <ul style="list-style-type: none"> • Loss of radio transmission from a thermostat for more than 1 hours • Loss of radio transmission from an interface (optional) for more than 15 minutes
Channel during run mode	<ul style="list-style-type: none"> • Red, on – actuators activated • Red, flashing – thermostat communication error or low battery indication • Red flashing – tamper alarm (public thermostat T-163) • Off – no demand for heating or cooling
Channel during registering mode	<ul style="list-style-type: none"> • Red, on – thermostat registered but with communication errors • Green, on – thermostat registered and communication is OK • Red, flashing – selector pointing at channel • Green, flashing – channel selected to be registered • Off – channel not pointed, nor registered
Channel during forced mode	<ul style="list-style-type: none"> • Red, on – actuators activated • Red, flashing – selector pointing at channel • Off – channel not pointed, nor activated

15.5 Restore from backup

If an existing Uponor Smatrix Wave controller has been replaced, installation data (including thermostat registration data) from the replaced controller can be reused to setup the new controller.



CAUTION!

Make sure the controller is powered off before ejecting the microSD card.



NOTE!

When replacing a controller, the microSD card from the replaced unit must be used in the new controller. Otherwise all registrations must be redone.



NOTE!

When a controller has been replaced, no additional units can be added to the system without redoing the whole installation. Replace the microSD card with the new one again, or format the existing one, and redo the installation procedure with the additional units.

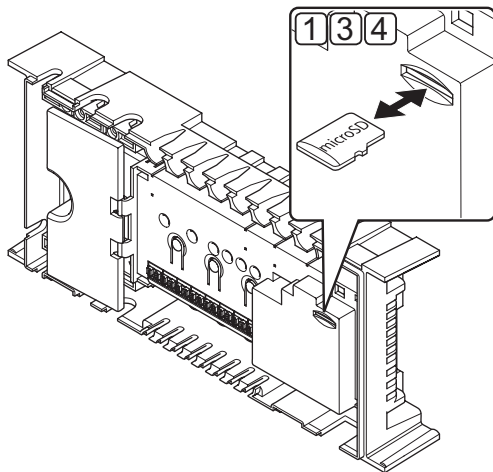

Preparation

1. Eject the microSD card from the malfunctioning controller.

Restore from backup to new controller

2. Power off the new controller.
3. Eject the existing microSD card from the new controller.
4. Insert the microSD card containing the installation data from the malfunctioning controller into the new one.
5. Power on the new controller.

The new controller is now setup with the installation data from the malfunctioning one.

16 Troubleshooting

The table below shows problems and alarms that can occur with Uponor Smatrix Wave and describes solutions. A common cause of a problem though may be due to wrongly installed loops or mixed up thermostats.

In case of mixed up thermostats in a Uponor Smatrix Wave system with interface I-167, use the room check function, see section 14.7 System settings for more information.

Problem	Indication	Probable cause	Solutions
Fluctuating floor temperature	Floor temperature is changing abnormally between hot and cold in heating mode	Supply water temperature is too high	Check boiler or shunt If an interface (optional) is connected to the system, run supply diagnostic test
	Room temperature does not match setpoint on thermostat, and actuators shut on/off on a fixed interval	Heating fall back function is activated due to lost communication with thermostat	Check the connection of the room thermostat Check batteries in room thermostat Check the interface (optional) for an error indicating that a thermostat has lost connection Reconnect if the connection is lost
	Room temperature does not match setpoint on thermostat	The thermostat is placed in direct sunlight or close to other heat sources The thermostat is placed in the wrong room.	Check placement of the thermostat according to installation instructions and change location if needed Check the placement of the thermostats and change rooms if needed. If an interface is available the room check function can be used. <i>See section 14.7 Settings > Room check for more information.</i>
The room is too cold (or too warm in cooling mode)	Press – or + buttons to display the temperature setpoint on the thermostat Temperature setpoint is displayed on the interface, in the room information menu	The thermostat setting is too low	Change the temperature setpoint Use maximum and minimum settings in the interface (optional) to protect the system from consequences of unreasonable temperature settings
	The temperature displayed on the thermostat changes after the thermostat is moved	The thermostat may be influenced by an external heat source	Change location of the thermostat
	See installation report and controller/channel numbering on the thermostat label	The thermostats of individual rooms are incorrectly registered	Place the thermostat in the correct room or change the thermostat registration in the controller
	See installation report and controller/channel numbering on the thermostatic head label	The thermostatic heads of individual rooms are incorrectly registered/installed	Place the thermostatic head in the correct room or change its registration on the controller
	White indicator cannot be seen in window of an actuator	An actuator does not open	Replace the actuator Contact the installer
	Setpoint temperature displayed in the room information menu is lower than the temperature set on the thermostat	Incorrect minimum/maximum limitation	Change the minimum/maximum limitation in the interface (optional)
	ECO in room information menu	ECO mode	Change ECO profile or assign another profile to the room in the interface (optional) Reduce the ECO setback value for the thermostat
	Supply temperature from the integrated heat pump (optional) is too low after deactivating heat pump integration in the interface	Heat pump integration is still activated in the connected heat pump	Deactivate heat pump integration in the heat pump (<i>see documentation for the heat pump</i>) Disconnect the wires between the heat pump integration connectors on the controller and the heat pump

Problem	Indication	Probable cause	Solutions
The room is too warm (or too cold in cooling mode)	Corresponding loop is warm even after a long period without heat call	An actuator does not close	Contact the installer Check that the actuator is correctly installed Replace the actuator
The floor is cold	The room temperature OK but the floor is cold	No heat demand from the underfloor heating system The room is heated by another heat source	
All rooms are cold (or warm in cooling mode)	Holiday mode	Icon displayed in the interface (optional)	Cancel Holiday mode
	ECO mode for rooms in room information menu	ECO mode	Change ECO profile or assign another profile to the room Reduce the ECO setback value for the thermostat Reduce the General ECO setback value in the interface (optional)
	Check the chiller (boiler) information and operation mode of the interface	The system is in cooling (heating) mode	Correct signal from external device needed
Disturbing noise from the pump at the same time and day of the week			Change time for pump exercise (requires interface I-167)
No communication	Communication error Software versions incompatible	Registration lost	Contact the installer Check registration status of the interface (optional) and the controller Register the interface again (optional)
Communication failure between the controllers	Communication error	Registration to controller is lost	Contact the installer Check the registration status of the interface (optional) and controller Check the controller configuration
Frozen display in the interface (optional)	No response when pressing a button	General failure	Restart the interface (power off the interface, wait about 10 seconds and power it on again)







16.1 Troubleshooting after installation

Problem	Indication	Probable cause	Solutions
The system does not start	The power indicator in the controller is off	There is no AC power to the controller	<ol style="list-style-type: none"> 1. Check that the controller is connected to AC power 2. Check the wiring in the 230 V compartment 3. Check that there is 230 V AC power in the wall socket
	There is 230 V AC power in the wall socket	Blown controller fuse or faulty power cable	<ol style="list-style-type: none"> 1. Replace the fuse and/or power cable and plug
Poor radio reception	Repeated radio alarms	<p>The antenna is installed inside a metal cabinet, or too close to other shielding objects</p> <p>Building structure unfavourable for radio transmission</p>	Change the antenna location. If the problem persists, contact the installer
The thermostats is faulty	Channel LEDs in the controller continue flashing	The antenna is not correctly installed or positioned	Check the wiring and the antenna connection









16.2 Digital thermostats T-166, T-168 and T-169 alarms/problems

An alarm is sent when more than 1 hours have elapsed since the controller received the last radio signal from the thermostat.

The table below shows problems that can occur in the digital thermostats T-166 and T-168.

Indication	Probable cause	Solutions
Battery icon  is displayed	Thermostat battery power is running low	Replace the batteries
The display is off	The batteries are discharged or wrong type of batteries are used	Replace the batteries
	The batteries are installed upside down (reverse polarity)	Install the batteries correctly
Radio transmission icon is displayed but the signals are received only when the thermostat is close to the antenna	Transmitter working with reduced signal intensity	<p>Force the thermostat to transmit by changing the temperature setpoint</p> <p>Replace thermostat</p>
	New installations in building shield radio signals (for example, metal door safe)	Try to find a new position for the thermostat and/or the antenna, or, if possible, move the shielding object
No radio transmission icon  is displayed on thermostat screen when -/+ buttons are pressed	The transmitter broken in the thermostat	<p>Force the thermostat to transmit by changing the temperature setpoint</p> <p>Replace the thermostat</p>
Relative humidity icon  is displayed (T-168 only)	The relative humidity limit is reached	Lower the humidity level by increasing the ventilation or temperature setpoint
The icon for floor temperature sensor  flashes	Faulty temperature sensor	<p>Check the connection of the floor sensor</p> <p>Disconnect the floor temperature sensor and check it with an ohmmeter. The value must be around 10 kohms</p>
The icon for outdoor temperature sensor  flashes	Faulty temperature sensor	<p>Check the connection of the outdoor sensor</p> <p>Disconnect the outdoor sensor and check it with an ohmmeter. The value must be around 10 kohms</p>
The icon for indoor temperature sensor  flashes	Faulty temperature sensor	<p>Contact the installer or replace the thermostat</p> <p>Disconnect the remote temperature sensor (if connected) and check it with an ohmmeter. The value must be around 10 kohms</p>

The table below shows problems that can occur in the digital thermostat T-169.

Indication	Probable cause	Solutions
Alarm icon  is displayed	An error has occurred	Go to the alarm list for more information
Battery icon  is displayed in the alarm list	Thermostat battery power is running low	Replace the battery
The display is off	The battery is discharged or wrong type of battery is used	Replace the battery
	The battery are installed incorrectly (reverse polarity)	Install the battery correctly
Radio transmission error icon  is displayed in the alarm list	Transmitter working with reduced signal intensity	Force the thermostat to transmit by changing the temperature setpoint Replace thermostat
	New installations in building shield radio signals (for example, metal door safe)	Try to find a new position for the thermostat and/or the antenna, or, if possible, move the shielding object
	The transmitter broken in the thermostat	Force the thermostat to transmit by changing the temperature setpoint Replace the thermostat
Relative humidity icon  is displayed in the alarm list	The relative humidity limit is reached	Lower the humidity level by increasing the ventilation or temperature setpoint
Floor temperature sensor icon  is displayed in the alarm list	Faulty temperature sensor	Check the connection of the floor sensor
		Disconnect the floor temperature sensor and check it with an ohmmeter. The value must be around 10 kohms
Outdoor temperature sensor icon  is displayed in the alarm list	Faulty temperature sensor	Check the connection of the outdoor sensor
		Disconnect the outdoor sensor and check it with an ohmmeter. The value must be around 10 kohms
Indoor temperature sensor icon  is displayed in the alarm list	Faulty temperature sensor	Contact the installer or replace the thermostat
Remote temperature sensor icon  is displayed in the alarm list	Faulty temperature sensor	Contact the installer or replace the remote sensor
		Disconnect the remote temperature sensor (if connected) and check it with an ohmmeter. The value must be around 10 kohms

16.3 Analogue thermostats T-161, T-163 and T-165 alarms/problems

An alarm is sent when more than 1 hour have elapsed since the controller received the last radio signal from the thermostat.

The table below lists problems that can occur in thermostats T-161, T-163 and T-165.

Indication	Probable cause	Solutions
The channel LED on the controller flashes	The public thermostat T-163 is removed from the wall	Check the thermostat settings and put it back on the wall
The LED on the thermostat (T-163 or T-165) flashes twice	The thermostat battery power is running low	Replace the batteries
The LED on the thermostat (T-161) flashes every two hours	The thermostat battery power is running low	Replace the battery
Low battery alarm displayed in the interface		
Floor temperature limit settings available for the room where the thermostat (T-161) is registered	No floor temperature sensor is connected to the thermostat	<ol style="list-style-type: none"> 1. Connect the floor temperature sensor to the thermostat 2. Remove the battery from the thermostat 3. Wait about 30 seconds 4. Insert the battery again <p>The thermostat will now be configured with a floor sensor</p>
	More than one hour had passed between startup of the thermostat, and the sensor being inserted	<ol style="list-style-type: none"> 1. Remove the battery from the thermostat 2. Wait about 30 seconds 3. Insert the battery again <p>The thermostat will now be configured with a floor sensor</p>

16.4 Thermostatic head T-162 alarms/problems

An alarm is sent when more than 1 hours have elapsed since the controller received the last radio signal from the thermostatic head.



The table below shows problems that can occur in the thermostatic head T-162.

Indication	Probable cause	Solutions
The text "bAt" is shown in the display	Thermostatic head battery power is running low	Replace the batteries
The text "POS" is shown in the display	The thermostatic head valve stroke calibration has not been performed correctly.	Install the thermostatic head on a radiator and make sure the valve stroke calibration is performed correctly. An Adaptor might be needed if the actuator does not reach the valve pin.
The display is off	The batteries are discharged or wrong type of batteries are used	Replace the batteries
	The batteries are installed upside down (reverse polarity)	Install the batteries correctly
	The battery protection sticker is not removed	Remove the battery protection sticker
Radio transmission icon is displayed but the signals are received only when the thermostat is close to the antenna	Transmitter working with reduced signal intensity	<ol style="list-style-type: none"> 1. Force the thermostatic head to receive new setpoint from thermostat by changing the temperature setpoint 2. Wait a couple of minutes 3. Press the </> buttons on the thermostatic head until setpoint is shown 4. Replace the thermostatic head if the setpoint doesn't match the thermostat setpoint
	New installations in building shield radio signals (for example, metal door safe)	Try to find a new position for the thermostat and/or the antenna, or, if possible, move the shielding object
No radio transmission icon (📶) is displayed on thermostatic head screen when </> buttons are pressed	The transmitter broken in the thermostatic head	<ol style="list-style-type: none"> 1. Force the thermostatic head to receive new setpoint from thermostat by changing the temperature setpoint 2. Wait a couple of minutes 3. Press the </> buttons on the thermostatic head until setpoint is shown 4. Replace the thermostatic head if the setpoint doesn't match the thermostat setpoint

16.5 Controller alarms/problems

An alarm is sent when more than 1 hour have elapsed since the controller received the last radio signal from the thermostat.

The table below lists problems that can occur in the controller.

Indication	Probable cause	Solutions
The power LED and channel LED on the controller flashes	The antenna is out of position or a wire is disconnected	Install the antenna in a correct position with the cable correctly connected
Alarm in the interface The battery icon  is displayed in room information on the interface or thermostat	The batteries in the thermostat are discharged	Replace the batteries When the error is resolved, the thermostat screen displays the room temperature and the battery icon  disappears
Radio alarm in interface The radio icon  is displayed in room information on the thermostat The power LED and thermostat LEDs in the controller for the connected channels flash	The thermostat is out of radio range	Reduce the distance between the thermostat and controller or change location of the thermostat in the room

16.6 Contact the installer

For installer contact information, see the installation report in the end of this document. Prepare the following information before contacting an installer:

- Installation report
- Drawings of the underfloor heating system (if available)
- List of all alarms, including time and date

16.7 Installer instructions

To determine if a problem is caused by the supply system or the control system, loosen the actuators from the manifold for the room concerned, wait a few minutes and check if the flow pipe of the underfloor heating loop becomes warm.

If the pipe does not become warm, the problem is in the heating system. If the loop becomes warm, the cause could be the room control system.

A supply system defect can be indicated by no warm water in the manifold. Check the boiler and circulation pump.

17 Technical data

17.1 Technical data

General	
IP	IP20 (IP: degree of inaccessibility to active parts of the product and degree of water)
Max. ambient RH (relative humidity)	85% at 20 °C
Thermostat	
CE marking	
ERP	IV
Low voltage tests	EN 60730-1* and EN 60730-2-9***
EMC (electromagnetic compatibility requirements) tests	EN 60730-1 and EN 301-489-3
ERM (electromagnetic compatibility and radio spectrum matters) tests	EN 300 220-3
Power supply (T-163, T-165, T-166, and T-168)	Two 1.5 V AAA alkaline batteries
Power supply (T-161 and T-169)	1 x CR2032 3V
Voltage (T-163, T-165, T-166, and T-168)	2.2 V to 3.6 V
Voltage (T-161 and T-169)	2.4 V to 3.6 V
Operating temperature	0 °C to +45 °C
Storage temperature	-10 °C to +65 °C
Radio frequency	868.3 MHz
Transmitter duty cycle	<1%
Connection terminals (T-163, T-165, T-166, and T-168)	0.5 mm ² to 2.5 mm ²
Connection terminals (T-161 and T-169)	0.25 mm ² to 0.75 mm ² solid, or 0.34 mm ² to 0.5 mm ² flexible with ferrules
Interface (optional)	
CE marking	
Low voltage tests	EN 60730-1 and EN 60730-2-1
EMC (electromagnetic compatibility requirements) tests	EN 60730-1
ERM (electromagnetic compatibility and radio spectrum matters) tests	EN 300 220-3
Power supply	230 V AC +10/-15%, 50 Hz in wall box or mini USB connection
Operating temperature	0 °C to +45 °C
Storage temperature	-20 °C to +70 °C
Radio frequency	868.3 MHz
Transmitter duty cycle	<1%
Thermostatic head	
CE marking	
ERP (thermostat only)	IV
Low voltage tests	EN 60730-1* and EN 60730-2-9***
EMC (electromagnetic compatibility requirements) tests	EN 60730-1 and EN 301-489-3
ERM (electromagnetic compatibility and radio spectrum matters) tests	EN 300 220-3
Power supply	Two 1.5 V AAA alkaline batteries
Voltage	2.2 V to 3.6 V
Maximum stroke	3.5 mm
Maximum strength	70 N
Differential pressure	1.5 bar
Operating temperature	0 °C to +40 °C
Storage temperature	-10 °C to +50 °C
Radio frequency	868.3 MHz
Transmitter duty cycle	<1%

Controller/interface (optional) SD card	
Type	micro SDHC, UHS or Standard
Capacity	4 GB to 32 GB, FAT 32 formatting
Speed	Class 4 to 10 (or higher)
Relay module	
CE marking	
ERP	IV
Low voltage tests	EN 60730-1* and EN 60730-2-1**
EMC (electromagnetic compatibility requirements) tests	EN 60730-1 and EN 301-489-3
ERM (electromagnetic compatibility and radio spectrum matters) tests	EN 300 220-3
Power supply	230 V AC +10/-15%, 50 Hz or 60 Hz
Operating temperature	0 °C to +50 °C
Storage temperature	-20 °C to +70 °C
Maximum consumption	2 W
Radio frequency	868.3 MHz
Transmitter duty cycle	<1%
Relay outputs	230 V AC +10/-15%, 250 V AC 2.5 A maximum
Power connection	1 m cable with europlug (except UK)
Connection terminals	Up to 4.0 mm ² solid, or 2.5 mm ² flexible with ferrules
Antenna	
Power supply	From controller
Radio frequency	868.3 MHz
Transmitter duty cycle	<1%
Receiver class	2
Controller	
CE marking	
ERP	VIII
Low voltage tests	EN 60730-1* and EN 60730-2-1**
EMC (electromagnetic compatibility requirements) tests	EN 60730-1 and EN 301-489-3
ERM (electromagnetic compatibility and radio spectrum matters) tests	EN 300 220-3
Power supply	230 V AC +10/-15%, 50 Hz or 60 Hz
Internal fuse	T5 F3.15AL 250 V, 5x20 3.15A quick acting
Internal fuse, Heat pump output	TR5-T 8.5 mm Wickmann 100 mA Time lag
Operating temperature	0 °C to +45 °C
Storage temperature	-20 °C to +70 °C
Maximum consumption	45 W
Pump and boiler relay outputs	230 V AC +10/-15%, 250 V AC 8 A maximum
General purpose input (GPI)	Only dry contact
Heat pump input	12 – 24 V DC /5 – 20 mA
Heat pump output	5 – 24 V DC /0.5 – 10 mA, current sink ≤ 100 mW
Valve outputs	24 V AC, 0.2 A average, 0.4 A peak
Power connection	1 m cable with europlug (except UK)
Connection terminals for power, pump, GPI and boiler	Up to 4.0 mm ² solid, or 2.5 mm ² flexible with ferrules
Connection terminals for valve outputs	0.2 mm ² to 1.5 mm ²

*) EN 60730-1 Automatic electrical controls for household and similar use
-- Part 1: General requirements

**) EN 60730-2-1 Automatic electrical controls for household and similar use
-- Part 2-1: Particular requirements for electrical controls for electrical household appliances

**) EN 60730-2-9 Automatic electrical controls for household and similar use
-- Part 2-9: Particular requirements for temperature sensing controls

Usable in all Europe



Declaration of conformity:

We hereby declare under our own responsibility that products dealt with by these instructions satisfy all essential demands linked to the information stated in the Safety instruction booklet.

17.2 Technical specifications

Cables	Standard cable length	Maximum cable length	Wire gauge
Cable from controller to antenna	0.50 m	5 m	CAT.5e or CAT.6, RJ 45 connector
Cable from controller to actuator	0.75 m	20 m	Controller: 0.2 mm ² to 1.5 mm ²
External sensor cable to thermostat	5 m	5 m	0.6 mm ²
Floor sensor cable to thermostat	5 m	5 m	0.75 mm ²
Outdoor sensor cable to thermostat	-	5 m	Twisted pair
Cable from relay switch to controller GPI input	2 m	20 m	Controller: Up to 4.0 mm ² solid, or 2.5 mm ² flexible with ferrules Relay: 1.0 mm ² to 4.0 mm ²
Cable to/from heat pump to controller heat pump input/output	-	30 m	Twisted pair

17.3 Controller layout

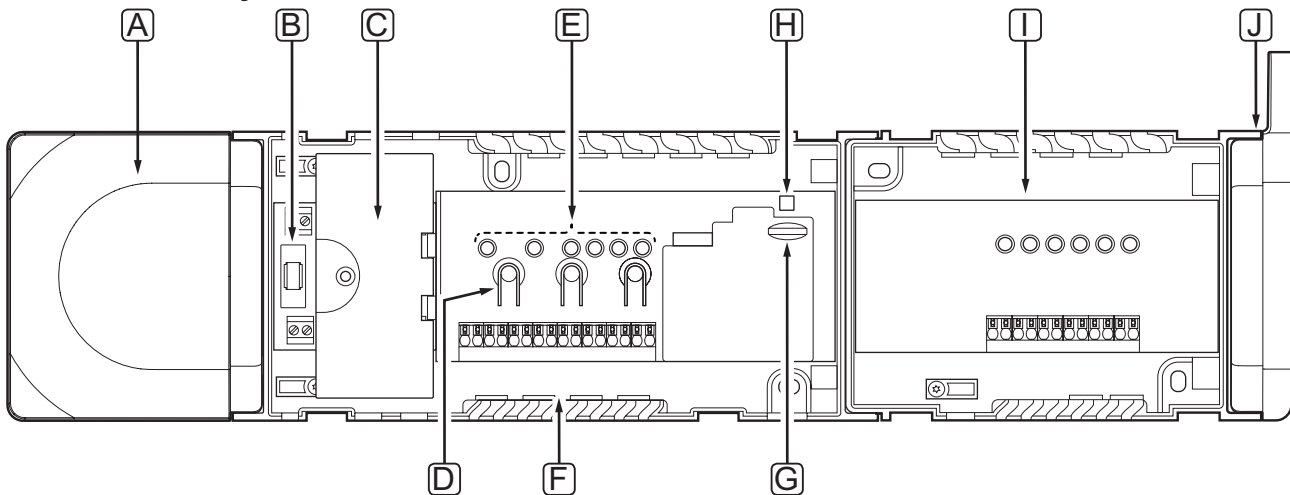

Item	Description
A	Transformer, 230 V AC 50 Hz power module
B	Fuse (T5 F3.15AL 250 V)
C	Optional inputs and outputs (pump and boiler management, and heat pump connection)
D	Channel registration buttons
E	LEDs for channels 01 – 06
F	Quick connectors for actuators
G	MicroSD card
H	Power LED
I	Uponor Smatrix Wave M-160 (optional slave module)
J	Uponor Smatrix Wave A-165, (antenna) RJ-45 connector

17.4 Wiring diagrams

UPONOR SMATRIX WAVE CONTROLLER

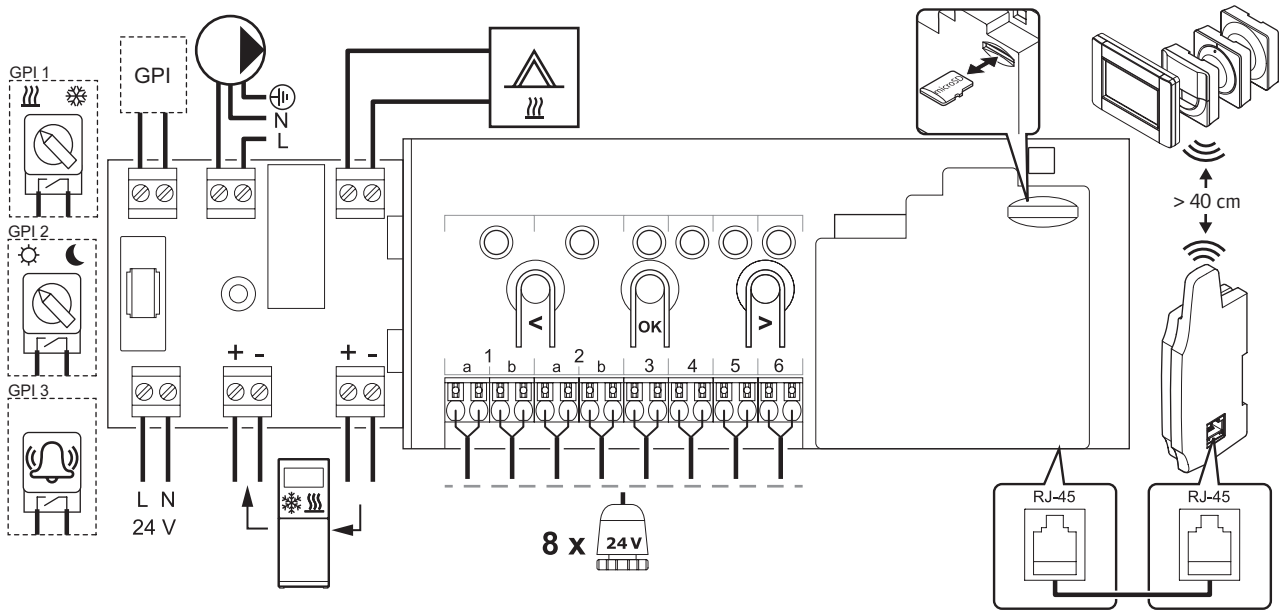

SLAVE MODULE

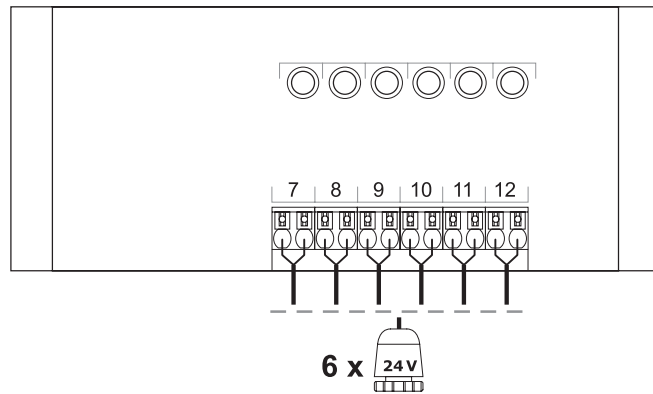

17.5 Dimensions

CONTROLLER (WITH TRANSFORMER AND ANTENNA)

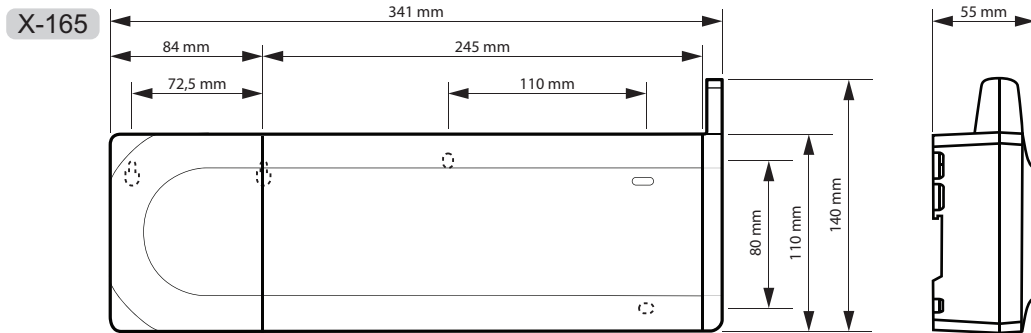

CONTROLLER (WITH SLAVE MODULE, TRANSFORMER AND ANTENNA)

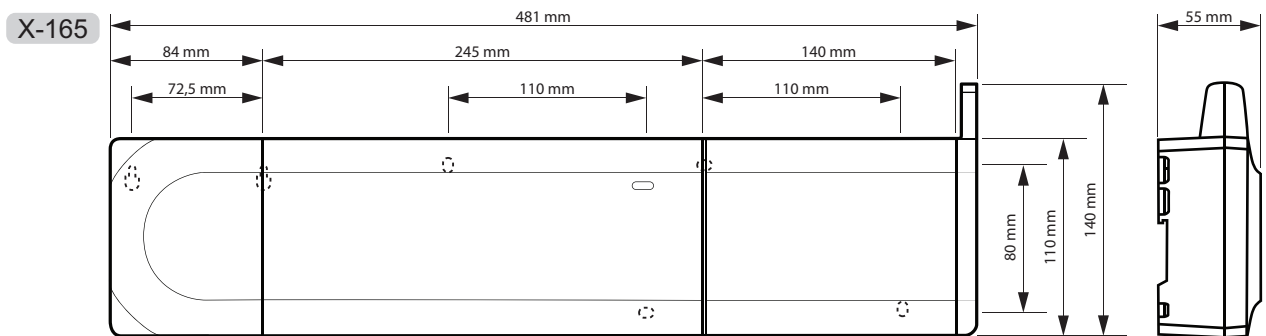

INTERFACE

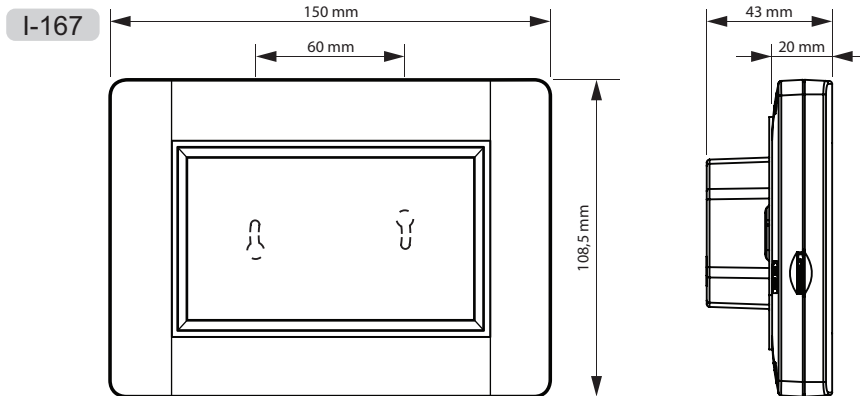

THERMOSTATS

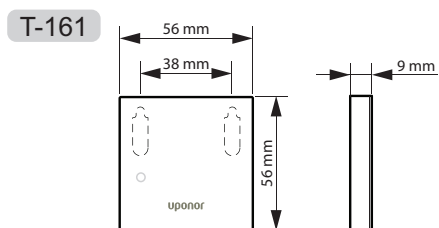
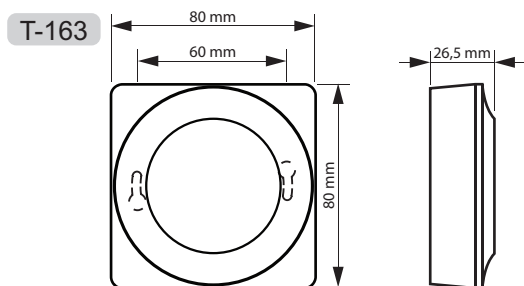
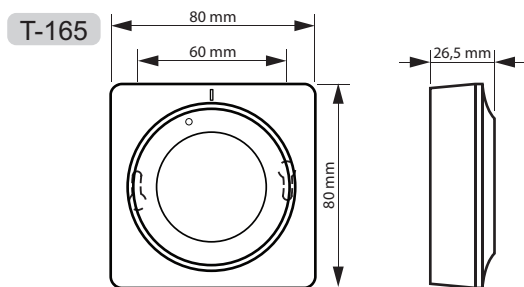
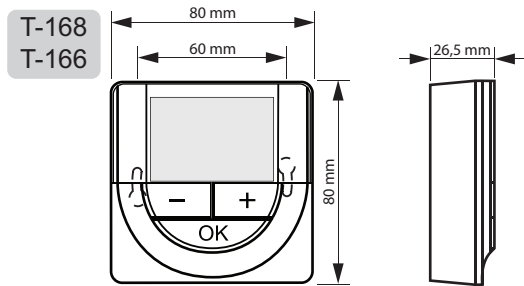
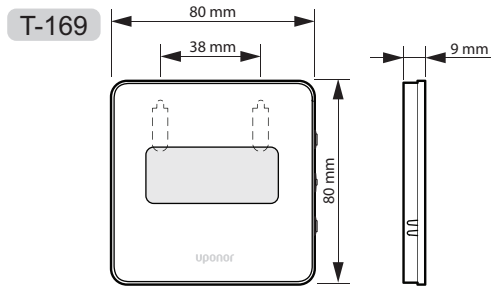

THERMOSTATIC HEAD

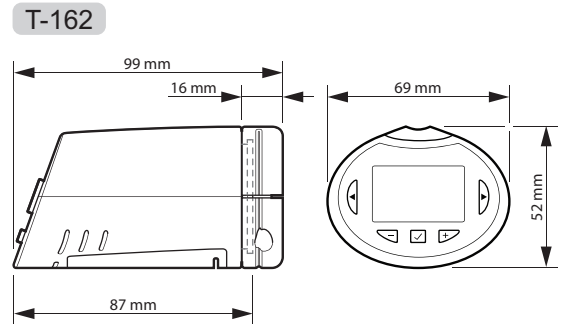



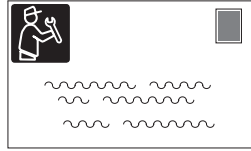
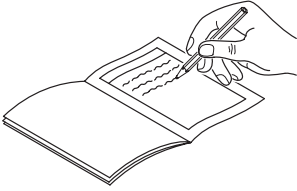

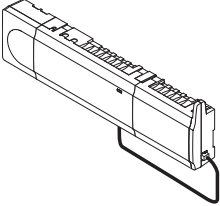
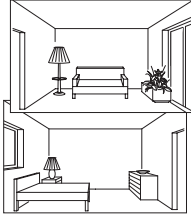



18 Installation report



	Controller # 1	Controller # 2	Controller # 3	Controller # 4	
Registered system device					Room name
Interface					
Relay module					
Outdoor sensor					
Heating/cooling switch sensor					
Heating/cooling switch					
ECO/Comfort switch					
Pump	Yes <input type="checkbox"/>	Yes <input type="checkbox"/>	Yes <input type="checkbox"/>	Yes <input type="checkbox"/>	
	No <input type="checkbox"/>	No <input type="checkbox"/>	No <input type="checkbox"/>	No <input type="checkbox"/>	

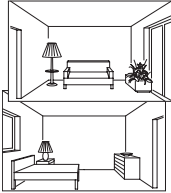

18.1 Controller 1

Thermostat	Controller channel						Slave module channel					
	1	2	3	4	5	6	7	8	9	10	11	12
 T-169												
 T-168												
 T-166												
 T-165												
 T-163												
 T-162												
 T-161												
Connected external sensor												
Floor sensor												
Outdoor sensor												
Remote sensor												
Connected actuator												
												
Room name												
												



.....









.....

.....

.....

.....

18.2 Controller 2

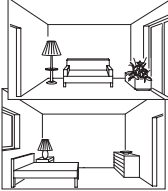
Thermostat	Controller channel						Slave module channel					
	1	2	3	4	5	6	7	8	9	10	11	12
 T-169												
 T-168												
 T-166												
 T-165												
 T-163												
 T-162												
 T-161												
Connected external sensor												
Floor sensor												
Outdoor sensor												
Remote sensor												
Connected actuator												
												
Room name												
												



.....









.....

.....

.....

.....

18.3 Controller 3

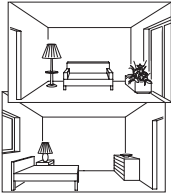
Thermostat	Controller channel						Slave module channel					
	1	2	3	4	5	6	7	8	9	10	11	12
 T-169												
 T-168												
 T-166												
 T-165												
 T-163												
 T-162												
 T-161												
Connected external sensor												
Floor sensor												
Outdoor sensor												
Remote sensor												
Connected actuator												
												
Room name												
												



.....









.....

.....

.....

.....

18.4 Controller 4

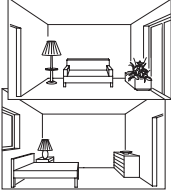
Thermostat	Controller channel						Slave module channel					
	1	2	3	4	5	6	7	8	9	10	11	12
 T-169												
 T-168												
 T-166												
 T-165												
 T-163												
 T-162												
 T-161												
Connected external sensor												
Floor sensor												
Outdoor sensor												
Remote sensor												
Connected actuator												
												
Room name												
												



.....

.....

.....

.....

.....



Uponor Corporation
www.uponor.com

Uponor reserves the right to make changes, without prior notification, to the specification of incorporated components in line with its policy of continuous improvement and development.

Uponor