

Xtratherm UK Ltd

Park Road
Holmewood Industrial Park
Holmewood
Chesterfield
Derbyshire S42 5UY

Tel: 0371 222 1033 Fax: 0371 222 1044
e-mail: info@xtratherm.com
website: www.xtratherm.com



Agrément Certificate
10/4803
Product Sheet 2

XTRATHERM SAFE-R INSULATION

XTRATHERM SAFE-R PARTIAL FILL CAVITY BOARD

This Agrément Certificate Product Sheet⁽¹⁾ relates to Xtratherm Safe-R Partial Fill Cavity Board, comprising rigid phenolic board with a composite foil-facing on both sides, for use as a partial fill thermal insulation in new external masonry cavity walls up to 25 m in height in domestic and non-domestic buildings.

(1) Hereinafter referred to as 'Certificate'.

CERTIFICATION INCLUDES:

- factors relating to compliance with Building Regulations where applicable
- factors relating to additional non-regulatory information where applicable
- independently verified technical specification
- assessment criteria and technical investigations
- design considerations
- installation guidance
- regular surveillance of production
- formal three-yearly review.

KEY FACTORS ASSESSED

Thermal performance — the product thermal conductivity $\lambda_{90/90}$ value ranges from $0.020 \text{ W}\cdot\text{m}^{-1}\cdot\text{K}^{-1}$ to $0.021 \text{ W}\cdot\text{m}^{-1}\cdot\text{K}^{-1}$, depending on thickness (see section 6).

Liquid water penetration — the external leaf and residual cavity detailing must be suitably designed and constructed to limit rain ingress. The product can bridge the inner leaf dpc (see section 7).

Condensation — the insulation core has a water vapour resistivity of approximately $171 \text{ MN}\cdot\text{s}\cdot\text{g}^{-1}\cdot\text{m}^{-1}$ and each foil-facing has a water vapour resistance of $0.71 \text{ MN}\cdot\text{s}\cdot\text{g}^{-1}$, but the risk of interstitial condensation will depend on the construction and should be assessed for each project (see section 8).

Behaviour in relation to fire — the product can be used in suitably designed walls (see section 9).

Durability — the product is rot-proof, dimensionally stable and durable and will remain effective as insulation for the life of the building (see section 12).



The BBA has awarded this Agrément Certificate to the company named above for the product described herein. The product has been assessed by the BBA as being fit for its intended use provided it is installed, used and maintained as set out in this Certificate.

On behalf of the British Board of Agrément

Sean Moriarty — Head of Approvals
Energy and Ventilation

Greg Cooper
Chief Executive

Date of Second issue: 7 March 2013

Originally certificated on 14 December 2010

The BBA is a UKAS accredited certification body — Number 113. The schedule of the current scope of accreditation for product certification is available in pdf format via the UKAS link on the BBA website at www.bbacerts.co.uk

Readers are advised to check the validity and latest issue number of this Agrément Certificate by either referring to the BBA website or contacting the BBA direct.

British Board of Agrément
Bucknalls Lane
Watford
Herts WD25 9BA

©2013

tel: 01923 665300
fax: 01923 665301
e-mail: mail@bba.star.co.uk
website: www.bbacerts.co.uk

Regulations

In the opinion of the BBA, Xtratherm Safe-R Partial Fill Cavity Board, if used in accordance with this Certificate, will meet or contribute to meeting the relevant requirements of the following Building Regulations (the presence of a UK map indicates that the subject is related to the Building Regulations in the region or regions of the UK depicted):



The Building Regulations 2010 (England and Wales) (as amended)

Requirement:	C2(a)	Resistance to moisture
Comment:		The product does not absorb water by capillary action and therefore may be used in situations where it bridges the damp-proof course (dpc). See section 7.5 of this Certificate.
Requirement:	C2(c)	Resistance to moisture
Comment:		The product can contribute to satisfying this Requirement. See sections 8.1 and 8.3 of this Certificate.
Requirement:	L1(a)(i)	Conservation of fuel and power
Comment:		The product can contribute to meeting this Requirement. See sections 6.1 and 6.2 of this Certificate.
Regulation:	7	Materials and workmanship
Comment:		The product is acceptable. See section 12 and the <i>Installation</i> part of this Certificate.
Regulation:	26	CO₂ emission rates for new buildings
Comment:		The product can contribute to satisfying this Regulation. See sections 6.1 and 6.2 of this Certificate.



The Building (Scotland) Regulations 2004 (as amended)

Regulation:	8(1)	Fitness and durability of materials and workmanship
Comment:		The product can contribute to a construction satisfying this Regulation. See section 12 and the <i>Installation</i> part of this Certificate.
Regulation:	9	Building standards applicable to Construction
Standard:	2.6	Spread to neighbouring buildings
Comment:		The product is combustible but may be used in walls of buildings in accordance with the exceptions permitted in this Standard, with reference to clauses 2.6.5 ⁽¹⁾ and 2.6.6 ⁽²⁾ . See section 9.5 of this Certificate.
Standard:	3.4	Moisture from the ground
Comment:		The product does not absorb water by capillary action and therefore may be used in situations where they bridges the dpc, with reference to clause 3.4.1 ⁽¹⁾⁽²⁾ and 3.4.5 ⁽¹⁾⁽²⁾ to this Standard. See section 7.5 of this Certificate.
Standard:	3.15	Condensation
Comment:		Walls incorporating the product can satisfy this Standard, with reference to clauses 3.15.1 ⁽¹⁾⁽²⁾ , 3.15.4 ⁽¹⁾⁽²⁾ and 3.15.5 ⁽¹⁾⁽²⁾ . See sections 8.2 and 8.3 of this Certificate.
Standard:	6.1(b)	Carbon dioxide emissions
Standard:	6.2	Building insulation envelope
Comment:		Walls incorporating the product can satisfy, or contribute to satisfying these Standards, with reference to clauses 6.1.6 ⁽¹⁾ , 6.2.1 ⁽¹⁾⁽²⁾ , 6.2.3 ⁽¹⁾ , 6.2.4 ⁽²⁾ , 6.2.5 ⁽²⁾ , 6.2.9 ⁽¹⁾ , 6.2.10 ⁽¹⁾ , 6.2.11 ⁽¹⁾⁽²⁾ , 6.2.12 ⁽²⁾ and 6.2.13 ⁽¹⁾⁽²⁾ . See sections 6.1 and 6.2 of this Certificate.
Standard:	7.1(a)(b)	Statement of sustainability
Comment:		The product can contribute to meeting the relevant requirements of Regulation 9, Standards 1 to 6 and therefore will contribute to a construction meeting a bronze level of sustainability as defined in this Standard. In addition the product can contribute to a construction meeting a higher level of sustainability as defined in this Standard, with reference to clauses 7.1.4 ⁽¹⁾⁽²⁾ [Aspects 1 ⁽¹⁾⁽²⁾ and 2 ⁽¹⁾], 7.1.6 ⁽¹⁾⁽²⁾ [Aspects 1 ⁽¹⁾⁽²⁾ and 2 ⁽¹⁾] and 7.1.7 ⁽¹⁾⁽²⁾ [Aspect 1 ⁽¹⁾⁽²⁾]. See section 6.1 of this Certificate.
Regulation:	12	Building standards applicable to conversions
Comment:		Comments made in relation to the product under Regulation 9, Standards 1 to 6 also apply to this Regulation, with reference to clause 0.12.1 ⁽¹⁾⁽²⁾ and Schedule 6 ⁽¹⁾⁽²⁾ . (1) Technical Handbook (Domestic). (2) Technical Handbook (Non-Domestic).



The Building Regulations (Northern Ireland) 2012

Regulation:	23(a)(i)(iii)(b)	Fitness of materials and workmanship
Comment:		The product is acceptable. See section 12 and the <i>Installation</i> part of this Certificate.
Regulation:	28(b)	Resistance to moisture and weather
Comment:		The product does not absorb water by capillary action and therefore may be used in situations where it bridges the dpc. See section 7.5 of this Certificate.
Regulation:	29	Condensation
Comment:		The product can contribute to satisfying this Regulation. See section 8.3 of this Certificate.
Regulation:	39(a)(i)	Conservation measures
Regulation:	40(2)	Target carbon dioxide emission rate
Comment:		The product can contribute to satisfying these Regulations. See sections 6.1 and 6.2 of this Certificate.

Information in this Certificate may assist the client, CDM co-ordinator, designer and contractors to address their obligations under these Regulations.

See section: 3 *Delivery and site handling* (3.3) of this Certificate.

Additional Information

NHBC Standards 2013

NHBC accepts the use of Xtratherm Safe-R Partial Fill Cavity Board, when installed and used in accordance with this Certificate, in relation to *NHBC Standards*, Chapter 6.1 *External masonry walls*.

Technical Specification

1 Description

1.1 Xtratherm Safe-R Partial Fill Cavity Board is manufactured from closed-cell phenolic foam, faced with a composite foil-facing on both sides.

1.2 The boards have the nominal characteristics as shown in Table 1.

Length (mm)	1200
Width (mm)	450
Thickness (mm)	50 to 120
Minimum compressive strength at 10% compression (kPa)	125
Edge profile	Plain, tongue-and-groove

1.3 Only BBA approved insulation retaining fixings and compatible wall ties should be used with the boards.

1.4 Cavity wall ties in accordance with BS DD 140-2 : 1987 or BS EN 845-1 : 2003 and BS 5628-3 : 2005, BS EN 1996-2 : 2006, approved by the BBA, are suitable.

2 Manufacture

2.1 Raw materials are injected onto the lower foil-facer on a conveyor belt. The exothermic reaction expands the foam, which then comes into contact with the upper foil-facer. An automated process cures and cuts the product to the required size.

2.2 As part of the assessment and ongoing surveillance of product quality, the BBA has:

- agreed with the manufacturer the quality control procedures and product testing to be undertaken
- assessed and agreed the quality control operated over batches of incoming materials
- monitored the production process and verified that it is in accordance with the documented process
- evaluated the process for management of nonconformities
- checked that equipment has been properly tested and calibrated
- undertaken to carry out the above measures on a regular basis through a surveillance process, to verify that the specifications and quality control operated by the manufacturer are being maintained.

2.3 The management system of Xtratherm UK Ltd has been assessed and registered as meeting the requirements of BS EN ISO 9001 : 2008 by BRE Certification Ltd (Certificate 718).

3 Delivery and site handling

3.1 The product is delivered to site in polythene shrink-wrapped packs containing a label bearing the manufacturer's trade name, product description, and the BBA identification mark incorporating the number of this Certificate.

3.2 It is essential that the product is stored such that it is raised off the ground, is inside or under cover on a flat, dry, level surface in a well-ventilated area. The product must be protected from rain, snow and prolonged exposure to sunlight. Boards that have been allowed to get wet or that are damaged must not be used. Nothing should be stored on top of boards.

3.3 The product must not be exposed to a naked flame or other ignition sources. The product must not be exposed to solvents or other chemicals.

Assessment and Technical Investigations

The following is a summary of the assessment and technical investigations carried out on Xtratherm Safe-R Partial Fill Cavity Board.

Design Considerations

4 General

4.1 Xtratherm Safe-R Partial Fill Board Cavity is for use as a partial fill thermal insulation in new external masonry cavity walls up to 25 m in height in domestic and non-domestic buildings.

4.2 The product is effective in reducing the thermal transmittance (U value) of new external cavity walls with masonry inner and outer leaves (masonry includes clay and calcium silicate bricks, concrete blocks, natural and reconstituted stone blocks). It is essential that such walls are designed and constructed to incorporate the normal precautions to prevent moisture penetration.

4.3 Walls should be designed and constructed in accordance with the relevant recommendations of:

- BS 8000-3 : 2001
- BS EN 1996-1-1 : 2005, BS EN 1996-1-2 : 2005, BS EN 1996-2 : 2006 and BS EN 1996-3 : 2006 and their respective UK National Annexes.

4.4 It is essential that walls limit the risk of moisture ingress, see section 7.

4.5 As with any other form of cavity wall insulation, where buildings need to comply with NHBC Standards 2013, specifiers should observe the requirements of these Standards.

5 Practicability of installation

The product is designed to be installed by a competent general builder, or a contractor, experienced with this type of product.

6 Thermal performance

6.1 Calculations of thermal transmittance (U value) should be carried out in accordance with BS EN ISO 6946 : 2007 and BRE Report (BR 443 : 2006) Conventions for U-value calculations, using the declared thermal conductivity ($\lambda_{90/90}$ value) shown in Table 2 and a foil surface emissivity (ϵ) of 0.2. The U value of a completed wall will depend on the insulation thickness, number and type of fixings, the insulating value of the substrate masonry and its internal finish. When considering insulation requirements, designers should refer to the detailed guidance contained in the documents supporting the national Building Regulations. The U values shown in Table 3 indicate that the product can contribute to a wall achieving typical design U values referred to in those supporting documents.

Table 2 Thermal conductivity

Insulation thickness (mm)	Thermal conductivity ($\text{W}\cdot\text{m}^{-1}\cdot\text{K}^{-1}$)
50 to 99	0.021
100 to 120	0.020

Table 3 U values for the partial fill construction⁽¹⁾

Thickness ⁽²⁾ (mm)			U value ($\text{W}\cdot\text{m}^{-2}\cdot\text{K}^{-1}$)
Inner leaf – AAC block ($\lambda = 0.12 \text{ W}\cdot\text{m}^{-1}\cdot\text{K}^{-1}$) ⁽³⁾	Inner leaf – dense block ($\lambda = 1.13 \text{ W}\cdot\text{m}^{-1}\cdot\text{K}^{-1}$) ⁽⁴⁾		
75	90		0.19
60	80		0.22
50	65		0.25
50	60		0.27
50	60		0.28
50	55		0.30
50	50		0.35

(1) 50 mm residual cavity width.

(2) Nearest available thickness.

(3) With plasterboard on dabs internal finish.

(4) With plaster internal finish.

6.2 The product can maintain, or contribute to maintaining, continuity of thermal insulation at junctions between elements and openings. For Accredited Construction Details the corresponding psi values in BRE Information Paper IP 1/06 *Assessing the effects of thermal bridging at junctions and around openings*, Table 3 may be used in carbon emission calculations in Scotland and Northern Ireland. Detailed guidance for other junctions and on limiting heat loss by air infiltration can be found in:

England and Wales — Approved Documents to Part L and for new thermal elements to existing buildings, Accredited Construction Details (version 1.0). See also SAP 2009 *The Government's Standard Assessment Procedure for Energy Rating of Dwellings*, Appendix K and the *iSBEM User Manual* for new-build

Scotland — Accredited Construction Details (Scotland)

Northern Ireland — Accredited Construction Details (version 1.0).

7 Liquid water penetration

Rain ingress

7.1 Walls must be suitably designed, constructed and detailed to limit the risk of rain ingress, particularly in severe or very severe exposure zones (see also sections 4.3 and 7.4).

7.2 The product may be used in walls in any exposure zone where:

- a minimum residual cavity width of 50 mm is maintained
- mortar joints are weatherstruck in severe or very severe exposure zones
- an external render coat or other suitable finish is applied in locations where such application would be normal practice
- from ground level the maximum height of continuous cavity walls must not exceed 12 m; above 12 m the maximum height of continuous cavity wall must not exceed 7 m. In both cases, breaks should be in the form of continuous horizontal cavity trays and weepholes discharging to the outside
- where, for structural reasons, the cavity width is reduced, eg by the intrusion of ring beams, a minimum residual cavity width of 25 mm must be maintained and extra care must be taken with fixings and weatherproofing, eg inclusion of cavity trays with weepholes.

7.3 The product may be used in walls in the exposure zones shown in Table 4 where:

- a minimum residual cavity width of 25 mm is maintained (see also section 7.2)
- the wall height does not exceed 12 m
- component tolerances, quality of available building operatives and site supervision of the product ensure that the residual cavity is not bridged by mortar.

Table 4 Maximum allowable total exposure factor of different constructions

Construction	Maximum allowable exposure factor $E^{(1)}$
All external masonry walls protected by: <ul style="list-style-type: none"> • rendering (to BS EN 13914-1 : 2005) • slate hanging • timber, plastic or metal weatherboarding or cladding 	No restriction
One or more external masonry walls constructed from facing clay brickwork or natural stone, the porosity of which exceeds 20% by volume. Mortar joints must be flush pointed or weatherstruck	100
One or more external masonry walls constructed from calcium silicate bricks, concrete blocks, reconstituted stone, or natural stone, the porosity of which exceeds 20% by volume, or any material with raked mortar joints.	88

(1) Based upon the approach in BS 5618 : 1985 and also outlined in BBA information sheet No 10.

7.4 In all situations it is particularly important to ensure during installation that:

- the dpc should not project into the cavity at ground-floor level as it can lead to catching mortar droppings
- excess mortar is cleaned from the cavity face of the leading leaf and any debris removed from the cavity
- mortar droppings are cleaned from the exposed edges of installed boards
- the use of cavity battens and/or boards is strongly recommended to prevent bridging by mortar droppings
- wall ties are installed correctly and are thoroughly clean
- at lintel level, a cavity tray, stop ends and weepholes, must be provided
- installation of the boards is to be carried out to the highest level on each wall or the top edge of the insulation is protected by a cavity tray.

Moisture from the ground



7.5 When the product is used in situations where they bridge the dpc in walls, dampness from the ground will not pass through to the inner leaf provided the wall is detailed in accordance with the requirements and provisions of the documents supporting the national Building Regulations:

England and Wales — Approved Document C, section 5

Scotland — Mandatory Standard 3.4, clause 3.4.5⁽¹⁾⁽²⁾

(1) Technical Handbook (Domestic).

(2) Technical Handbook (Non-Domestic).

Northern Ireland — Technical Booklet C, Section 6.

8 Condensation

Surface condensation



8.1 Walls will limit the risk of surface condensation adequately when the thermal transmittance (U value) does not exceed $0.7 \text{ W}\cdot\text{m}^{-2}\cdot\text{K}^{-1}$ at any point, and the junctions with floors, roofs and openings are designed in accordance with *Limiting thermal bridging and air leakage: Robust construction details for dwellings and similar buildings* TSO 2002, BRE Information Paper IP 1/06 or section 6.2 of this Certificate.



8.2 For buildings in Scotland, constructions will be acceptable where the thermal transmittance (U value) of the wall does not exceed $1.2 \text{ W}\cdot\text{m}^{-2}\cdot\text{K}^{-1}$ at any point and openings and junctions with other elements comply with the guidance given in BS 5250 : 2011, Annex G or section 6.2 of this Certificate. Additional information can be found in BRE Report (BR 262 : 2002) *Thermal insulation: avoiding risks*.

Interstitial condensation



8.3 Walls will limit the risk of interstitial condensation adequately when they are designed and constructed in accordance with BS 5250 : 2011, Annexes D and G and the relevant guidance.

8.4 For the purposes of assessing the risk of interstitial condensation, the insulation core vapour resistivity may be taken as approximately $171 \text{ MN}\cdot\text{s}\cdot\text{g}^{-1}\cdot\text{m}^{-1}$ and a resistance value of $0.71 \text{ MN}\cdot\text{s}\cdot\text{g}^{-1}$ for each individual foil-facing.

8.5 If the product is to be used in the external wall of rooms expected to have high humidity, care must be taken to provide adequate permanent ventilation to avoid possible problems from the formation of interstitial condensation in the internal wall leaf.

9 Behaviour in relation to fire

9.1 The product does not prejudice the fire-resistance properties of the wall. It is unlikely to become ignited within the cavity when used in the context of this Certificate. If fire does penetrate into an unventilated cavity, the amount of air present will be insufficient to support combustion and flame spread will be minimal.

9.2 The requirements of the Building Regulations relating to fire spread in cavity walls can be met in buildings of all purpose groups without the need for cavity barriers, provided the construction complies with the provisions detailed in:

England and Wales — Approved Document B, Volume 1, Diagram 13, or Volume 2, Diagram 34

Northern Ireland — Technical Booklet E, Diagram 4.5.

9.3 A summary of these provisions is given here:

- the wall must consist of masonry inner and outer leaves, each at least 75 mm thick
- the cavity must not be more than 300 mm wide (Northern Ireland only)
- the cavity must be closed at the top of the wall and at the top of any opening
- in addition to the insulation, only the following combustible materials shall be placed in, or exposed to, the cavity:
 - timber lintels, window or door frames, or end of timber joists
 - pipe, conduit or cable
 - dpc, flashing, cavity closer or wall tie
 - domestic meter cupboard, provided that there are not more than two cupboards to a dwelling, the opening in the outer leaf is not more than 800 mm by 500 mm for each cupboard, and the inner leaf is not penetrated except by a sleeve not more than 80 mm by 80 mm, which is fire-stopped.

9.4 For constructions not covered by section 9.3, cavity barriers must be provided to comply with:

England and Wales — Approved Document B, Volume 1, Section 6, and Volume 2, Section 9

Scotland — Mandatory Standard 2.4, clauses 2.4.1⁽¹⁾⁽²⁾, 2.4.2⁽¹⁾⁽²⁾, 2.4.7⁽¹⁾ and 2.4.9⁽¹⁾

(1) Technical Handbook (Domestic).

(2) Technical Handbook (Non-Domestic).

Northern Ireland — Technical Booklet E, Paragraphs 4.36 to 4.40.



9.5 The product is combustible and may be used within one metre from a boundary, in walls with two leaves of masonry/concrete at least 75 mm thick, with barriers around all openings and at the top of the wall in accordance with Mandatory Standard 2.6, clauses 2.6.5⁽¹⁾ and 2.6.6⁽²⁾.

(1) Technical Handbook (Domestic).

(2) Technical Handbook (Non-Domestic).

9.6 Cavity walls should always have a cavity closer at the top of the cavity and around openings. Materials must not be taken past fire stops.

10 Proximity of flues and appliances

When installing the product in close proximity to certain flue pipes and/or heat producing appliances, the relevant provisions of the national Building Regulations are applicable:

England and Wales — Approved Document J, sections 1 to 4

Scotland — Mandatory Standard 3.19, clauses 3.19.1⁽¹⁾⁽²⁾ to 3.19.9⁽¹⁾⁽²⁾

(1) Technical Handbook (Domestic).

(2) Technical Handbook (Non-Domestic).

Northern Ireland — Technical Booklet L, Sections 1 to 6.

11 Maintenance

As the product is confined within the wall cavity and it has suitable durability (see section 12), maintenance is not required.

12 Durability



The product is durable, rot-proof and sufficiently stable, and will remain effective as an insulating material for the life of the building.

Installation

13 General

It is recommended that the inner leaf is constructed ahead of the outer leaf, as the product is fastened to the cavity face of the inner leaf to give a slightly enhanced thermal performance. It is essential that the spacing of wall ties/clips allows one long edge of each of the product to be secured at a minimum of two points.

14 Procedure

14.1 A section of the inner leaf is built with the first row of wall ties, at approximately 600 mm horizontal spacing, where the insulation is to begin. It is recommended that the wall ties are not placed directly on the dpc. The first run of the product may commence below dpc level to provide some edge insulation for the floor (see Figure 1).

Figure 1 First run of boards

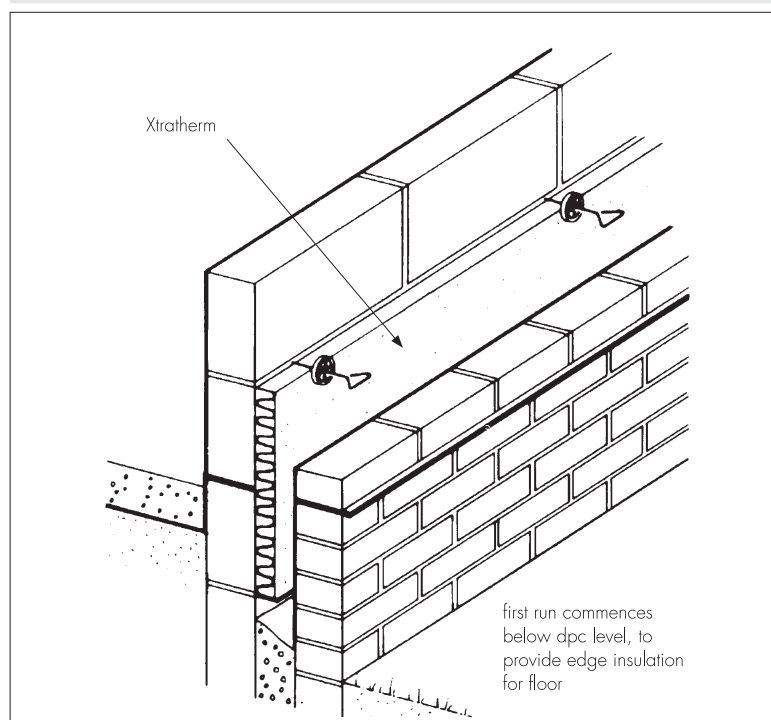

14.2 The leading leaf is built up to the required height, with wall ties placed at a vertical height of 450 mm ensuring the drip of the tie is located halfway across the residual cavity width. Excess mortar is cleaned from the cavity face of the leading leaf, and the product is placed on the wall ties, behind the retaining clips, to form a closely butt-jointed run.

14.3 The second row of wall ties is fitted to retain the tops of the product. It is essential that all wall ties slope downwards towards the outer leaf (see Figure 2) and at centres not exceeding 900 mm to ensure that each of the product is secured at a minimum of three points.

Figure 2 Detail of wall ties

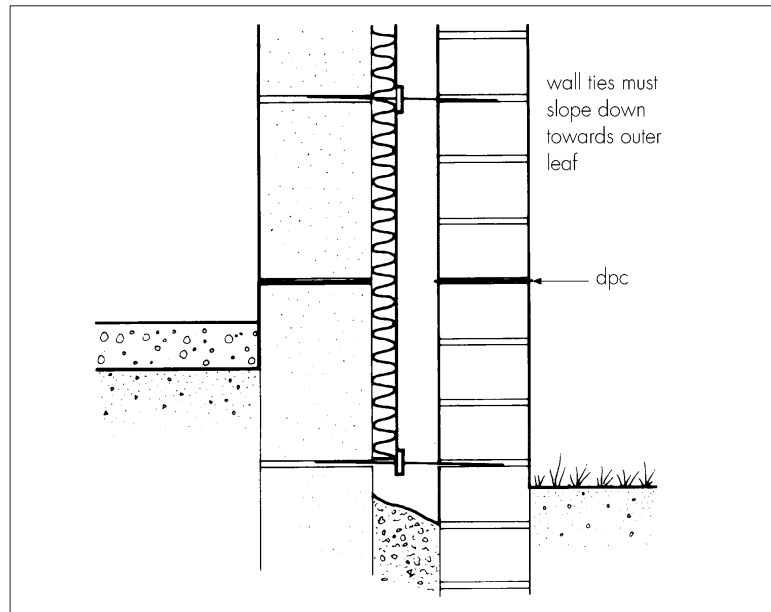

14.4 Additional ties may be required to satisfy structural requirements and/or to ensure adequate retention of the product or cut pieces.

14.5 The other leaf is then built up to the level of the top of the product.

14.6 All products should be butted with vertical joints staggered. Insulation products and wall ties should be staggered as construction proceeds and carried up to the highest level of wall, except where protected by a cavity tray.

14.7 After each section of the leading leaf is built, excess mortar should be removed from the cavity face and mortar droppings cleaned from exposed edges of the installed products, before installation of the next run of products. Use of a cavity board will protect the installed product's edges and help to keep the cavity clean as the following leaf is built (see Figures 3 and 4).

Figure 3 Use of cavity batten

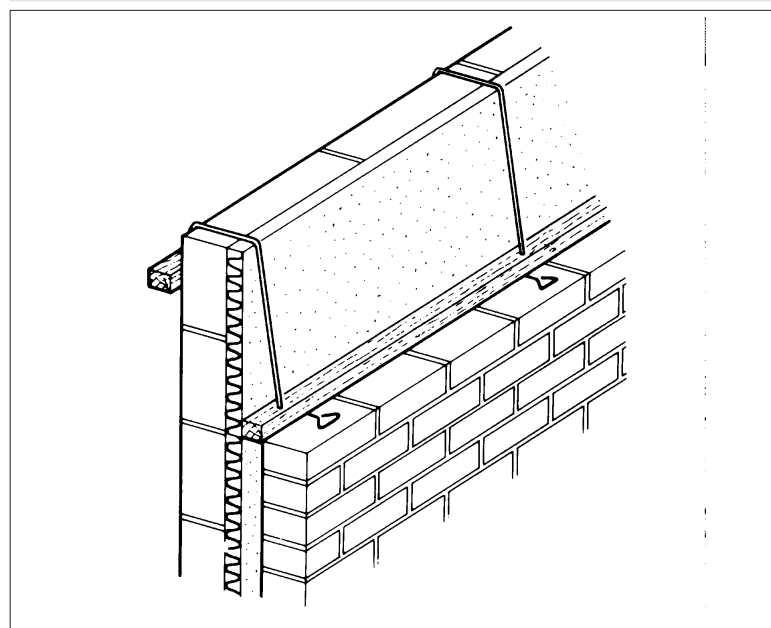
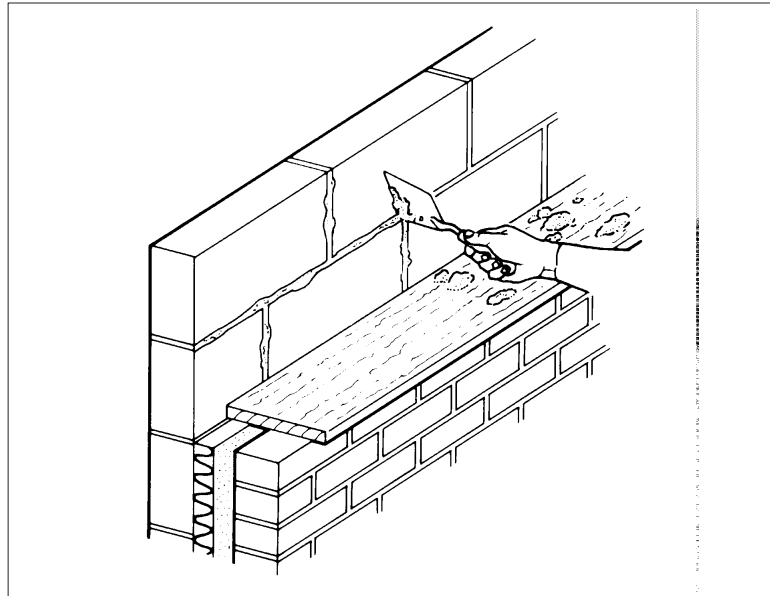

Figure 4 Use of cavity board



14.8 Where openings such as doors and windows are in close proximity, it is recommended that a continuous lintel or cavity tray is used. Individual lintels or cavity trays should have stop ends and be adequately drained.

14.9 The product can be cut, using a sharp knife or fine-toothed saw, to fit around windows, doors and air bricks. It is essential that cut pieces completely fill the spaces for which they are intended and are adequately secured — gaps should not be left in the insulation.

Protection

14.10 All building involving the product, particularly interrupted work, must conform to BS EN 1996-2 : 2006, Sections 3.2 *Acceptance, handling and storage of materials* and 3.6 *Curing and protective procedures during execution*.

Technical Investigations

15 Tests

Tests were carried out on Xtratherm Safe-R Partial Fill Cavity Board by the BBA in accordance with BS EN 13166 : 2008 to determine:

- dimensional stability
- compressive strength
- short term water absorption
- long term water absorption by partial immersion
- thermal conductivity.

16 Investigations

16.1 The manufacturing process was examined, including the methods adopted for quality control, and details were obtained of the quality and composition of the materials used.

16.2 Results of test data to BS EN 13166 : 2008 were assessed in relation to:

- dimensions
- squareness
- density
- λ value.

16.3 An assessment of the risk of interstitial condensation was made.

16.4 An assessment was made of typical constructions which achieve the design U values.

Bibliography

- BS 5250 : 2011 *Code of practice for control of condensation in buildings*
- BS 5618 : 1985 *Code of practice for thermal insulation of cavity walls (with masonry or concrete inner and outer leaves) by filling with urea-formaldehyde (UF) foam systems*
- BS 5628-3 : 2005 *Code of practice for the use of masonry — Materials and components, design and workmanship*
- BS 8000-3 : 2001 *Workmanship on building sites — Code of practice for masonry*
- BS DD 140-2 : 1987 *Wall ties — Recommendations for design of wall ties*
- BS EN 845-1 : 2003 *Specification for ancillary components for masonry — Ties, tension straps, hangers and brackets*
- BS EN 13166 : 2008 *Thermal insulation products for buildings — Factory made products of phenolic foam (PF) — Specification*
- BS EN 13914-1 : 2005 *Design, preparation and application of external rendering and internal plastering — External rendering*
- BS EN 1996-1-1 : 2005 *Eurocode 6 : Design of masonry structures — General rules for reinforced and unreinforced masonry structures*
- NA to BS EN 1996-1-1 : 2005 *UK National Annex to Eurocode 6 : Design of masonry structures — General rules for reinforced and unreinforced masonry structures*
- BS EN 1996-1-2 : 2005 *Eurocode 6 : Design of masonry structures — General rules — Structural fire design*
- NA to BS EN 1996-1-2 : 2005 *UK National Annex to Eurocode 6 : Design of masonry structures — General rules — Structural fire design*
- BS EN 1996-2 : 2006 *Eurocode 6 : Design of masonry structures — Design considerations, selection of materials and execution of masonry*
- NA to BS EN 1996-2 : 2006 *UK National Annex to Eurocode 6 : Design of masonry structures — Design considerations, selection of materials and execution of masonry*
- BS EN 1996-3 : 2006 *Eurocode 6 : Design of masonry structures : Simplified calculation methods for unreinforced masonry structures*
- NA to BS EN 1996-3 : 2006 *UK National Annex to Eurocode 6 : Design of masonry structures : Simplified calculation methods for unreinforced masonry structures*
- BS EN ISO 6946 : 2007 *Building components and building elements — Thermal resistance and thermal transmittance — Calculation method*
- BS EN ISO 9001 : 2008 *Quality management systems — Requirements*

17 Conditions

17.1 This Certificate:

- relates only to the product/system that is named and described on the front page
- is issued only to the company, firm, organisation or person named on the front page — no other company, firm, organisation or person may hold or claim that this Certificate has been issued to them
- is valid only within the UK
- has to be read, considered and used as a whole document — it may be misleading and will be incomplete to be selective
- is copyright of the BBA
- is subject to English Law.

17.2 Publications, documents, specifications, legislation, regulations, standards and the like referenced in this Certificate are those that were current and/or deemed relevant by the BBA at the date of issue or reissue of this Certificate.

17.3 This Certificate will remain valid for an unlimited period provided that the product/system and its manufacture and/or fabrication, including all related and relevant parts and processes thereof:

- are maintained at or above the levels which have been assessed and found to be satisfactory by the BBA
- continue to be checked as and when deemed appropriate by the BBA under arrangements that it will determine
- are reviewed by the BBA as and when it considers appropriate.

17.4 The BBA has used due skill, care and diligence in preparing this Certificate, but no warranty is provided.

17.5 In issuing this Certificate, the BBA is not responsible and is excluded from any liability to any company, firm, organisation or person, for any matters arising directly or indirectly from:

- the presence or absence of any patent, intellectual property or similar rights subsisting in the product/system or any other product/system
- the right of the Certificate holder to manufacture, supply, install, maintain or market the product/system
- actual installations of the product/system, including their nature, design, methods, performance, workmanship and maintenance
- any works and constructions in which the product/system is installed, including their nature, design, methods, performance, workmanship and maintenance
- any loss or damage, including personal injury, howsoever caused by the product/system, including its manufacture, supply, installation, use, maintenance and removal.
- any claims by the manufacturer relating to CE marking.

17.6 Any information relating to the manufacture, supply, installation, use, maintenance and removal of this product/system which is contained or referred to in this Certificate is the minimum required to be met when the product/system is manufactured, supplied, installed, used, maintained and removed. It does not purport in any way to restate the requirements of the Health and Safety at Work etc. Act 1974, or of any other statutory, common law or other duty which may exist at the date of issue or reissue of this Certificate; nor is conformity with such information to be taken as satisfying the requirements of the 1974 Act or of any statutory, common law or other duty of care.