



Applications

Suitable for installation within custodial, healthcare and commercial environments.

Features

- ~ Damage resistant
- ~ Anti-ligature
- ~ Integral moulded seat
- ~ Range of activation and control options available.



Dimensional Data

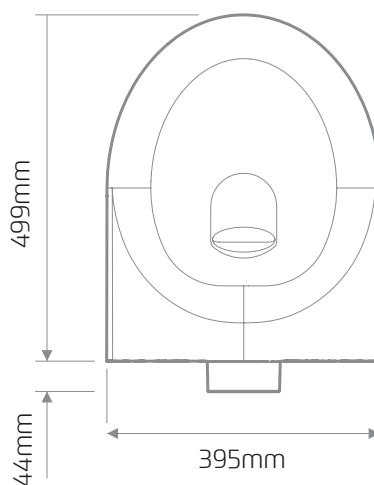
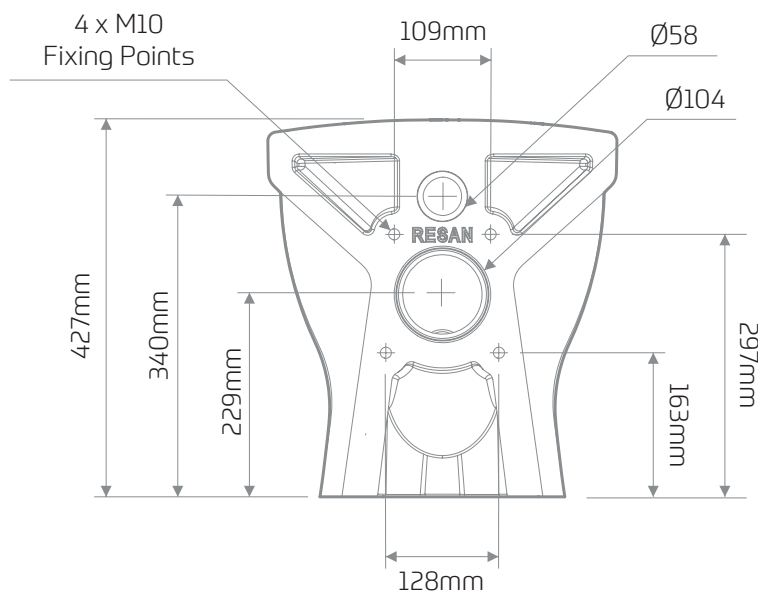

Technical Data

Material	Polymer Resin
Available Finishes	Matt, Gloss
Product Weight	46 kg
Fixing Orientation	Wall Fixed
Fixing Size	M10
Standard Conformity	BS 476 Pt.6 Fire propagation & surface spread of flame. ISO EN 19712-3-2007 Rated 5 for durability, stain resistance, cigarette burns etc.