

Ceiling swirl diffusers

Type TDF-SilentAIR

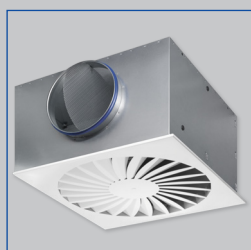

Plenum box with damper blade (optional)

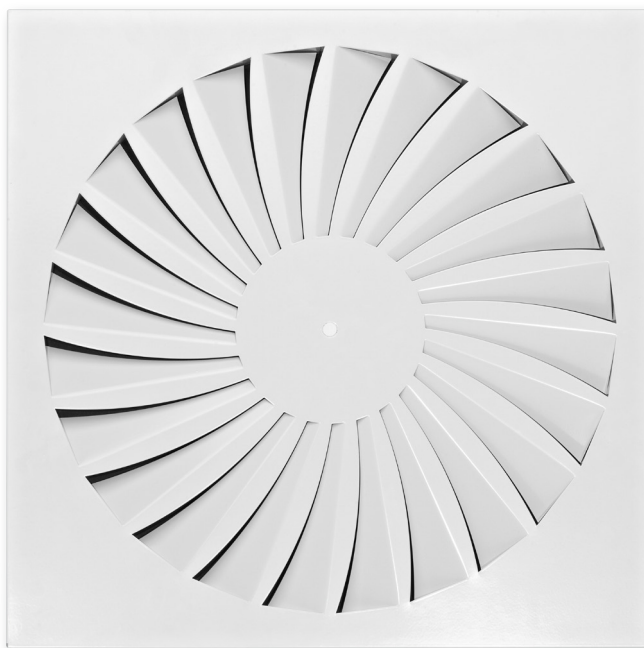
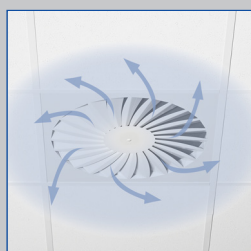

Horizontal swirling air discharge

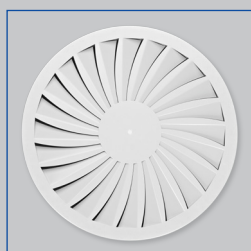

Circular diffuser face

With very low sound power level for comfort zones, with fixed air control blades

Circular and square ceiling swirl diffusers

- Nominal sizes 300, 400, 500, 600, 625
- Volume flow rate range 10 – 295 l/s or 36 – 1026 m³/h
- Diffuser face made of galvanised sheet steel, powder-coated
- For supply and extract air
- For variable and constant volume flows
- For all types of ceiling systems, and with an extended border also suitable for freely suspended installation
- High induction results in a rapid reduction of the temperature difference and airflow velocity
- Ideal for comfort zones

Optional equipment and accessories

- Exposed diffuser face available in RAL CLASSIC colours
- Horizontal or vertical duct connection
- Plenum box with cord-operated damper blade and pressure tap

Type		Page
TDF-SilentAIR	General information	TDF – 2
	Function	TDF – 4
	Technical data	TDF – 6
	Quick sizing	TDF – 7
	Specification text	TDF – 9
	Order code	TDF – 10
	Variants	TDF – 11
	Dimensions and weight	TDF – 13
	Product details	TDF – 16
	Installation examples	TDF – 17
	Installation details	TDF – 18
	Commissioning	TDF – 21
	Basic information and nomenclature	TDF – 23

Application

Application

- Type TDF-SilentAIR ceiling swirl diffusers are used as supply air or extract air diffusers for comfort zones
- Attractive design element for building owners and architects with demanding aesthetic requirements
- Horizontal swirling supply air discharge for mixed flow ventilation
- The efficient swirl creates high induction levels, thereby rapidly reducing the temperature difference and airflow velocity (supply air variant)
- For variable and constant volume flows
- For supply air to room air temperature differences from –12 to +10 K
- For room heights up to 4 m (lower edge of suspended ceiling)
- For all types of ceiling systems
- With an extended border also suitable for freely suspended installation (supply air variant)

Special characteristics

- Very low sound power level, ideal for comfort zones
- Fixed blades
- For all types of ceiling systems, and with an extended border also suitable for freely suspended installation
- Horizontal or vertical duct connection

Nominal sizes

- 300, 400, 500, 600, 625

Description

Variants

- TDF-SA-Q: Square diffuser face
- TDF-SA-R: Circular diffuser face
- TDF-SA-*-Z: Supply air
- TDF-SA-*-A: Extract air

Connection

- H: Horizontal duct connection
- V: Vertical duct connection

Parts and characteristics

- Circular or square diffuser face
- Diffuser face with fixed air control blades
- Simple installation of the diffuser face due to central fixing screw with decorative cap
- Damper blade for volume flow rate balancing (optional)

Attachments

- M: Damper blade for volume flow rate balancing
- MN: Pressure tap and cord-operated damper blade for volume flow rate balancing with the diffuser face in place

Accessories

- Lip seal

Construction features

- Spigot suitable for circular ducts to EN 1506 or EN 13180
- Spigot with groove for lip seal (if accessory lip seal has been ordered)

Materials and surfaces

- Diffuser face made of galvanised sheet steel
- V, H: Plenum box and cross bar made of galvanised sheet steel
- X: Plenum box made of plastic and galvanised sheet steel
- Lip seal made of rubber
- Diffuser face powder-coated RAL 9010, pure white
- P1: Powder-coated, RAL CLASSIC colour

Standards and guidelines

- Sound power level of the air-regenerated noise measured according to EN ISO 5135

Maintenance

- Maintenance-free as construction and materials are not subject to wear
- Inspection and cleaning to VDI 6022

Functional description

Ceiling swirl diffusers in air conditioning systems create a swirl to supply air to rooms. The resulting airflow induces high levels of room air, thereby rapidly reducing the airflow velocity and the temperature difference between supply air and room air. Ceiling swirl diffusers allow for large volume flow rates. The result is a mixed flow ventilation in comfort zones, with good overall room ventilation, creating only very little turbulence in the occupied zone.

Type TDF ceiling swirl diffusers have fixed blades.

Air discharge is horizontal radial. The supply air to room air temperature difference may range from -12 to $+10$ K.

A damper blade (optional) simplifies volume flow rate balancing for commissioning. Pressure tap and cord-operated damper blade (optional) allow for volume flow rate balancing with the diffuser face in place.

To give rooms an aesthetic, uniform look,

Type TDF diffusers may also be used for extract air.

Schematic illustration of the TDF-SA, with plenum box for horizontal duct connection

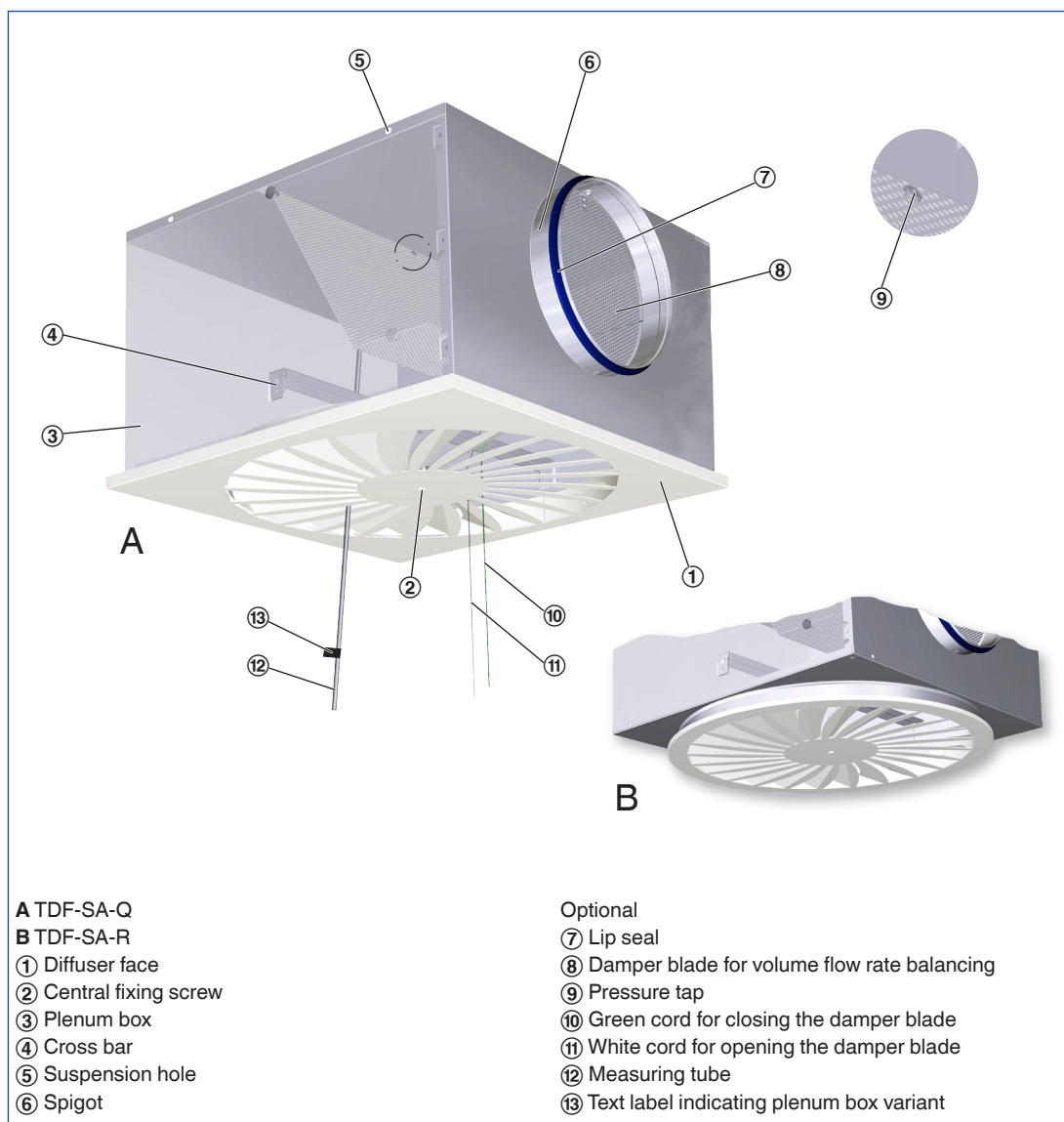

Horizontal omni directional air discharge



Nominal sizes	300, 400, 500, 600, 625 mm
Minimum volume flow rate, with $\Delta t_z = -6$ K	10 – 42 l/s or 36 – 151 m ³ /h
Maximum volume flow rate, with $L_{WA} \cong 50$ dB(A)	80 – 285 l/s or 288 – 1026 m ³ /h
Supply air to room air temperature difference	-12 to +10 K

Quick sizing tables provide a good overview of the volume flow rates and corresponding sound power levels and differential pressures.

The minimum volume flow rates apply to a supply air to room air temperature difference of -6 K.

The maximum volume flow rates apply to a sound power level of approx. 50 dB (A) with damper blade position 0° .

Exact values for all parameters can be determined with our Easy Product Finder design programme.

TDF-SA-Q-Z-H (supply air), sound power level and total differential pressure

Nominal size	\dot{V} l/s	\dot{V} m ³ /h	Damper blade position					
			0°		45°		90°	
			Δp_t Pa	L_{WA} dB(A)	Δp_t Pa	L_{WA} dB(A)	Δp_t Pa	L_{WA} dB(A)
300	10	36	1	<15	1	<15	2	<15
	35	126	14	27	16	26	29	26
	60	216	40	40	46	39	86	41
	80	288	71	50	83	49	153	53
400	18	65	1	<15	1	<15	3	<15
	65	234	13	24	17	22	34	24
	115	414	40	39	52	39	107	41
	160	576	76	50	101	51	206	52
500	27	97	1	<15	2	<15	5	<15
	80	288	12	23	16	22	47	26
	135	486	34	37	45	37	134	43
	195	702	71	50	95	51	280	56
600, 625	42	151	2	<15	2	<15	5	<15
	115	414	12	23	16	22	39	26
	185	666	32	38	41	36	101	41
	260	936	62	50	82	49	200	52

TDF-SA-R-Z-H (supply air), sound power level and total differential pressure

Nominal size	\dot{V} l/s	\dot{V} m ³ /h	Damper blade position					
			0°		45°		90°	
			Δp_t Pa	L_{WA} dB(A)	Δp_t Pa	L_{WA} dB(A)	Δp_t Pa	L_{WA} dB(A)
300	10	36	1	<15	1	<15	2	<15
	40	144	17	29	20	28	38	28
	70	252	53	45	63	45	118	45
	80	288	70	50	82	51	154	51
400	18	65	1	<15	1	<15	3	<15
	65	234	12	23	15	22	35	24
	115	414	39	38	45	38	110	41
	160	576	76	50	88	50	212	51
500	27	97	1	<15	2	<15	5	<15
	90	324	15	23	22	24	58	28
	155	558	45	39	65	40	171	45
	201	724	75	50	108	50	287	55
600, 625	42	151	2	<15	2	<15	5	<15
	130	468	16	26	21	25	50	30
	215	774	43	41	56	40	137	46
	265	954	65	50	86	48	208	53

TDF-SA-*-Z-V (supply air), sound power level and total differential pressure

Nominal size	\dot{V}	\dot{V}	Damper blade position					
			0°		45°		90°	
			Δp_t	L_{WA}	Δp_t	L_{WA}	Δp_t	L_{WA}
	l/s	m ³ /h	Pa	dB(A)	Pa	dB(A)	Pa	dB(A)
300	10	36	1	<15	1	<15	2	<15
	35	126	14	26	16	25	29	25
	60	216	40	40	46	39	85	40
	80	288	71	50	83	50	153	51
400	18	65	1	<15	1	<15	3	<15
	65	234	12	23	16	25	35	24
	115	414	39	39	50	40	110	42
	155	558	71	50	91	51	200	53
500	27	97	1	<15	2	<15	5	<15
	80	288	12	23	16	25	46	28
	130	468	31	37	42	39	121	44
	180	648	59	50	81	53	232	55
600, 625	42	151	2	<15	2	<15	5	<15
	115	414	13	26	19	28	42	32
	185	666	35	41	48	44	108	48
	230	828	54	49	74	52	166	57

This specification text describes the general properties of the product. Texts for variants can be generated with our Easy Product Finder design programme.

Ceiling swirl diffusers with square or circular diffuser face. Supply air and extract air variants for comfort zones. Diffuser face with fixed air control blades for horizontal swirling supply air discharge creating high induction levels. For installation into all types of suspended ceilings.

Ready-to-install component which consists of the diffuser face and a plenum box, side entry or top entry spigot, and suspension holes or suspension lugs.

The diffuser face is fixed to the cross bar with a central screw.

Spigot suitable for ducts to EN 1506 or EN 13180. Sound power level of the air-regenerated noise measured according to EN ISO 5135.

Special characteristics

- Very low sound power level, ideal for comfort zones
- Fixed blades
- For all types of ceiling systems, and with an extended border also suitable for freely suspended installation
- Horizontal or vertical duct connection

Materials and surfaces

- Diffuser face made of galvanised sheet steel

- V, H: Plenum box and cross bar made of galvanised sheet steel
- X: Plenum box made of plastic and galvanised sheet steel
- Lip seal made of rubber
- Diffuser face powder-coated RAL 9010, pure white
- P1: Powder-coated, RAL CLASSIC colour

Technical data

- Nominal sizes: 300, 400, 500, 600, 625 mm
- Minimum volume flow rate, with $\Delta t_z = -6$ K: 10 – 42 l/s or 36 – 151 m³/h
- Maximum volume flow rate, with $L_{WA} \approx 50$ dB(A): 80 – 285 l/s or 288 – 1026 m³/h
- Supply air to room air temperature difference: -12 to +10 K

Sizing data

- \dot{V} _____
[m³/h]
 - Δp_t _____
[Pa]
- Air-regenerated noise
- L_{WA} _____
[dB(A)]

TDF-SA

TDF-SA – Q – Z – H – M – L / 500 / P1 – RAL ...							
1	2	3	4	5	6	7	8

1 Type

TDF-SA Swirl diffuser

2 Construction style

- R** Circular
- Q** Square

3 System

- Z** Supply air
- A** Extract air

4 Connection

- H** Horizontal
- V** Vertical

5 Damper blade for volume flow rate balancing

- No entry: without damper blade
- M** With damper blade
- MN** With cords and pressure tap (only for connection type H)

6 Accessories

- No entry: without accessories
- L** With lip seal

7 Nominal size [mm]

- 300**
- 400**
- 500**
- 600**
- 625**

8 Exposed surface

- No entry: powder-coated RAL 9010, pure white
- P1** Powder-coated, specify RAL CLASSIC colour
 - Gloss level
 - RAL 9010 50 %
 - RAL 9006 30 %
 - All other RAL colours 70 %

Order example: TDF-SA-Q-Z-V-M-L/500/P1-RAL 9016

Construction style	Square
System	Supply air
Connection	Vertical
Damper blade for volume flow rate balancing	With
Accessories	Lip seal
Nominal size	500
Exposed surface	RAL 9016, traffic white, gloss level 70 %

TDF-SA-Q-Z

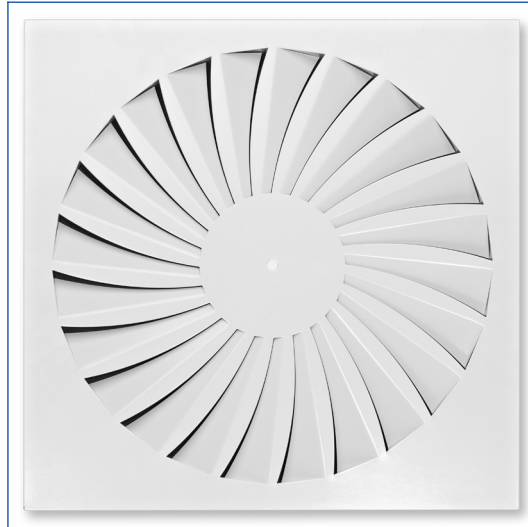

TDF-SA-Q-*-H

Variant

- Ceiling swirl diffuser with square diffuser face
- With plenum box for horizontal duct connection

Nominal sizes

- 300, 400, 500, 600, 625

Parts and characteristics

- Square diffuser face
- Plenum box for horizontal duct connection
- Square opening to accommodate the diffuser face
- Equalising element that ensures a uniform airflow through the diffuser face (supply air

TDF-SA-Q-*-V

Variant

- Ceiling swirl diffuser with square diffuser face
- With plenum box for vertical duct connection

Nominal sizes

- 300, 400, 500, 600, 625

Parts and characteristics

- Square diffuser face
- Plenum box for vertical duct connection
- Circular opening to accommodate the diffuser face
- Equalising element that ensures a uniform

TDF-SA-R-*-H

Variant

- Ceiling swirl diffuser with circular diffuser face
- With plenum box for horizontal duct connection

Nominal sizes

- 300, 400, 500, 600, 625

TDF-SA-R-Z/600

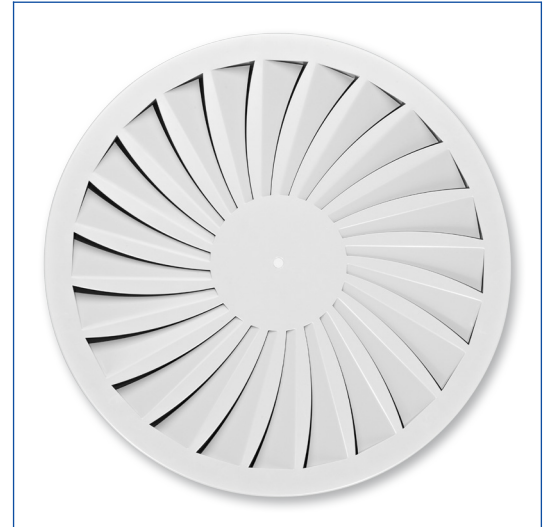

variant)

- Simple installation of the diffuser face due to central fixing screw with decorative cap
- Damper blade for volume flow rate balancing (optional)
- Pressure tap and cord-operated damper blade for volume flow rate balancing (optional)
- Lip seal (optional)

Construction features

- Spigot suitable for circular ducts to EN 1506 or EN 13180
- Spigot with groove for lip seal (if accessory lip seal has been ordered)

airflow through the diffuser face (supply air variant)

- Simple installation of the diffuser face due to central fixing screw with decorative cap
- Damper blade for volume flow rate balancing (optional)
- Lip seal (optional)

Construction features

- Spigot suitable for circular ducts to EN 1506 or EN 13180
- Spigot with groove for lip seal (if accessory lip seal has been ordered)

Parts and characteristics

- Circular diffuser face
- Plenum box for horizontal duct connection
- Circular opening to accommodate the diffuser face
- Equalising element that ensures a uniform airflow through the diffuser face (supply air variant)

- Simple installation of the diffuser face due to central fixing screw with decorative cap
- Damper blade for volume flow rate balancing (optional)
- Pressure tap and cord-operated damper blade for volume flow rate balancing (optional)

- Lip seal (optional)

Construction features

- Spigot suitable for circular ducts to EN 1506 or EN 13180
- Spigot with groove for lip seal (if accessory lip

TDF-SA-R*-V

Variant

- Ceiling swirl diffuser with circular diffuser face
- With plenum box for vertical duct connection

Nominal sizes

- 300, 400, 500, 600, 625

Parts and characteristics

- Circular diffuser face
- Plenum box for vertical duct connection
- Circular opening to accommodate the diffuser face
- Equalising element that ensures a uniform

airflow through the diffuser face (supply air variant)

- Simple installation of the diffuser face due to central fixing screw with decorative cap
- Damper blade for volume flow rate balancing (optional)
- Lip seal (optional)

Construction features

- Spigot suitable for circular ducts to EN 1506 or EN 13180
- Spigot with groove for lip seal (if accessory lip seal has been ordered)

Square diffuser face with plenum box for horizontal duct connection

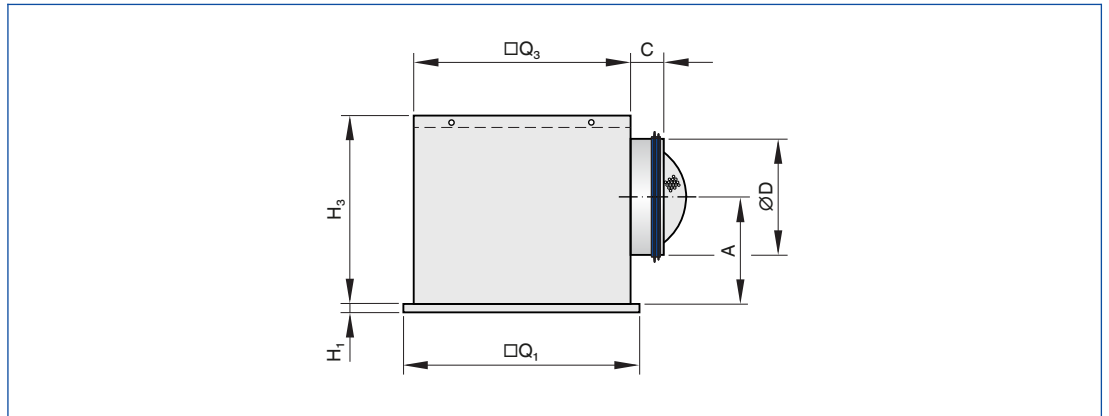

TDF-SA-Q-*-H

Nominal size	□Q ₁	H ₁	□Q ₃	H ₃	ØD	A	C	Plenum box	m
	mm	mm	mm	mm	mm	mm	mm		kg
300	298	8	290	250	158	139	50	AK-Uni-001	4.0
400	398	8	372	295	198	164	50	AK-Uni-002	6.2
500	498	8	476	295	198	164	50	AK-Uni-003	8.5
600	598	8	567	345	248	199	48	AK-Uni-004	11.6
625	623	8	567	345	248	199	48	AK-Uni-004	11.9

Weights apply to the supply air variant

Square diffuser face with plenum box for vertical duct connection

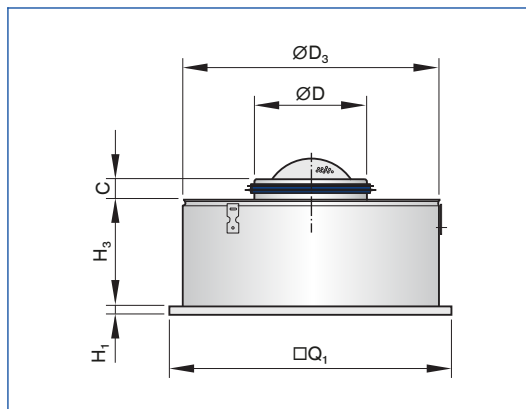

TDF-SA-Q-*-V

Nominal size	$\square Q_1$	H_1	$\varnothing D_3$	H_3	$\varnothing D$	C	m
	mm	mm	mm	mm	mm	mm	kg
300	298	8	275	200	158	50	3.0
400	398	8	364	200	198	50	4.7
500	498	8	462	200	198	50	6.7
600	598	8	559	200	248	48	8.9
625	623	8	559	200	248	48	9.2

Weights apply to the supply air variant

Circular diffuser face with plenum box for horizontal duct connection

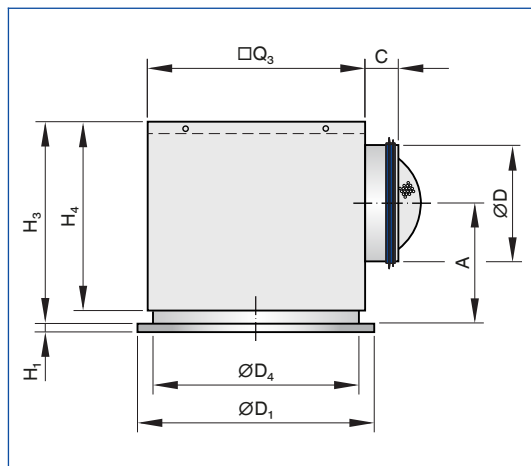

TDF-SA-R-*-H

Nominal size	$\varnothing D_1$	H_1	$\square Q_3$	H_3	$\varnothing D_4$	H_4	$\varnothing D$	A	C	Plenum box	m
	mm	mm	mm	mm	mm	mm	mm	mm	mm		kg
300	300	8	290	285	278	250	158	174	50	AK-Uni-013	4.2
400	400	8	372	330	362	295	198	199	50	AK-Uni-014	6.5
500	500	8	476	330	460	295	198	199	50	AK-Uni-015	9.0
600	600	8	567	380	557	345	248	234	48	AK-Uni-016	12.3
625	625	8	567	380	557	345	248	234	48	AK-Uni-016	12.5

Weights apply to the supply air variant

Circular diffuser face with plenum box for vertical duct connection

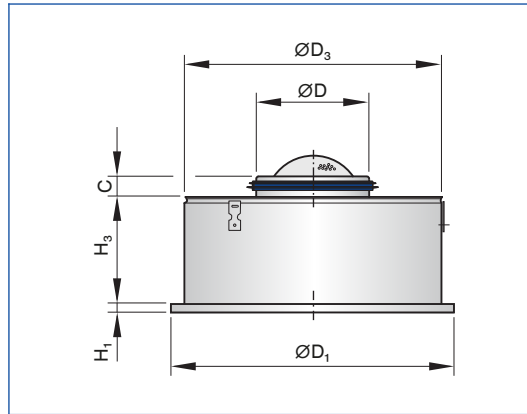

TDF-SA-R*-V

Nominal size	ØD ₁	H ₁	ØD ₃	H ₃	ØD	C	m
	mm	mm	mm	mm	mm	mm	kg
300	300	8	275	200	158	50	2.8
400	400	8	364	200	198	50	4.4
500	500	8	462	200	198	50	6.3
600	600	8	559	200	248	48	8.5
625	625	8	559	200	248	48	8.7

Weights apply to the supply air variant

Diffuser face TDF-SA-Q

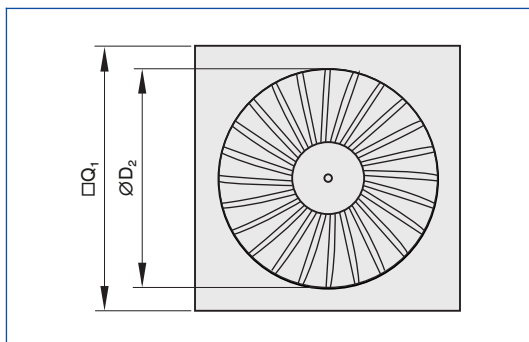

TDF-Q

Nominal size	$\square Q_1$ mm	$\varnothing D_2$ mm	A_{eff} m^2
300	298	254	0.0108
400	398	336	0.0193
500	498	440	0.0280
600	598	530	0.0400
625	623	530	0.0400

Diffuser face TDF-SA-R

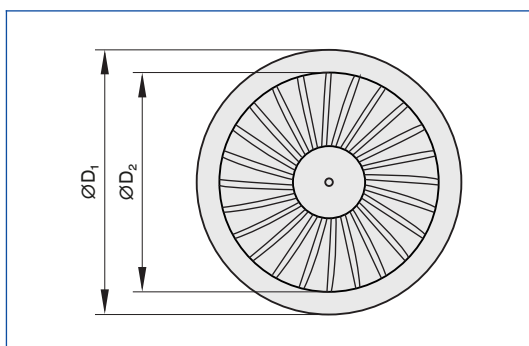

TDF-R

Nominal size	$\varnothing D_1$ mm	$\varnothing D_2$ mm	A_{eff} m^2
300	300	254	0.0108
400	400	336	0.0193
500	500	440	0.0280
600	600	530	0.0400
625	625	530	0.0400

Installation in T-bar ceilings



Installation in T-bar ceilings, arrangement in a row



Installation in continuous ceilings



Installation and commissioning

- Preferably for rooms with a clear height up to 4.0 m
- Flush ceiling installation
- Freely suspended installation only with an extended border (supply air variant)
- Horizontal or vertical duct connection
- If necessary, carry out volume flow rate balancing with the damper blade

These are only schematic diagrams to illustrate installation details.

Flush ceiling installation with square plenum box

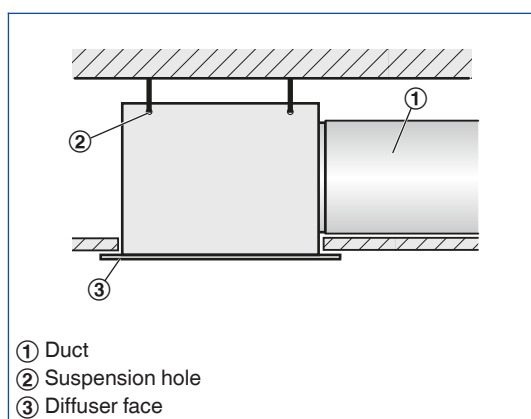

- Horizontal duct connection
- Four suspension holes
- Suspension with cords, wires or hangers, to be provided by others

Freely suspended installation

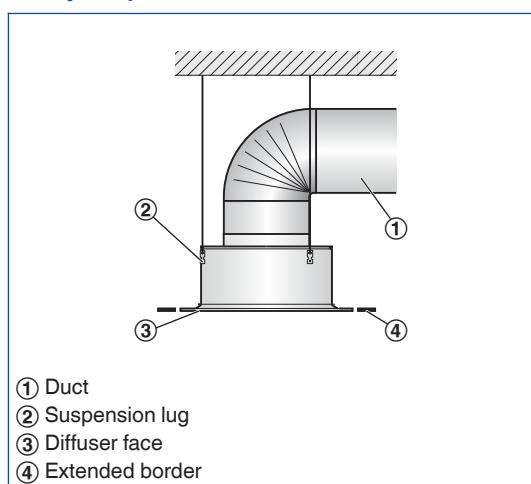

- Vertical duct connection
- Three suspension lugs
- Suspension with cords, wires or hangers, to be provided by others

Diffuser face – sealing

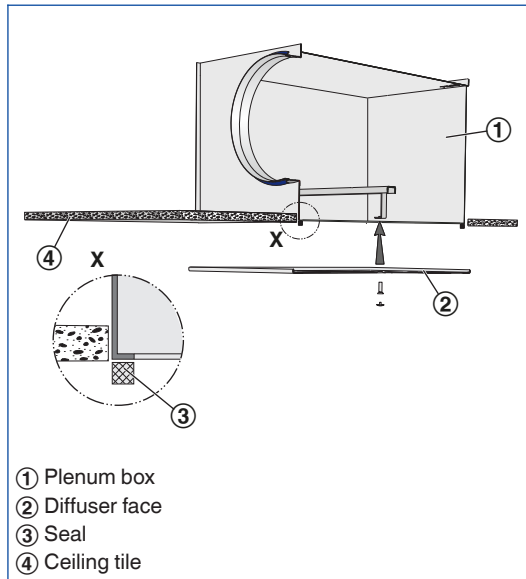

- The self-adhesive sealing tape (supplied) has to be applied to the return edges of the plenum box by others

Diffuser face – central screw fixing

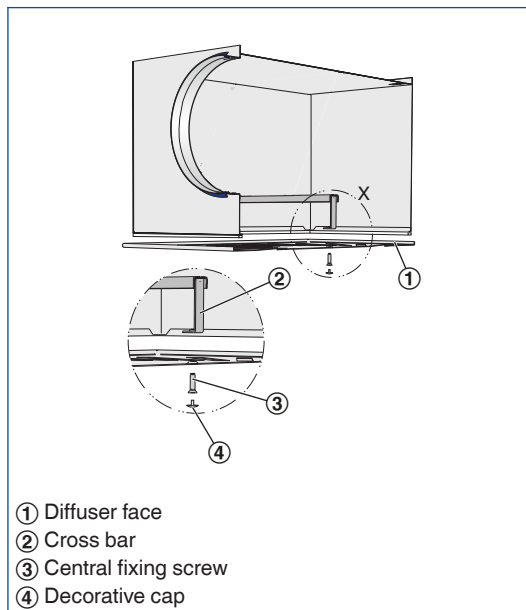

- Using the central fixing screw, fix the diffuser face to the cross bar of the plenum box
- Attach the decorative cap

Ceiling systems

Installation into grid ceilings

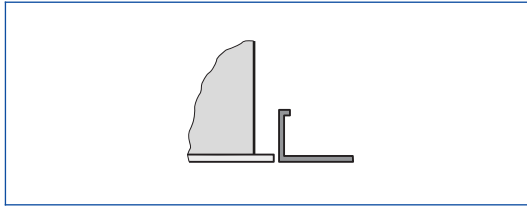

- Fix the plenum box to the ceiling
- The ceiling tile of the grid ceiling is independent of the ceiling diffuser
- Fix the diffuser face after the ceiling has been completed

Installation in continuous ceilings

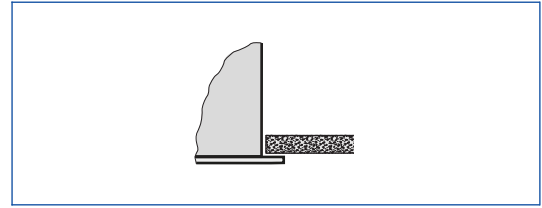

- Fix plenum box (including diffuser face, if necessary) to the ceiling
- Adjust plasterboard ceiling tile as required
- If necessary, fix the diffuser face after the ceiling has been completed

Installation in T-bar ceilings

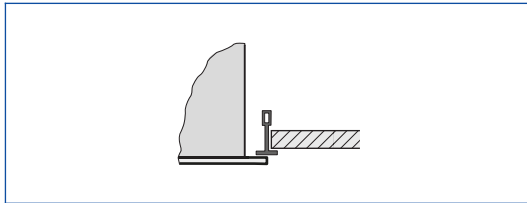

- Fix the plenum box to the ceiling
- The T-bar ceiling is independent of the ceiling diffuser
- Fix the diffuser face below the T-bars after the ceiling has been completed

Volume flow rate balancing

When several diffusers are connected to just one volume flow controller, it may be necessary to balance the volume flow rates.

- Ceiling diffusers with universal plenum box and damper blade (variant -M): The diffuser face can be removed to access the damper blade; the damper blade can then be set to any position between 0 and 90°
- Ceiling diffusers with universal plenum box, damper blade and pressure tap (variant -MN): The diffuser face need not be removed since the damper blade can be set with two cords (white and green).

Volume flow rate measurement

Ceiling diffusers with universal plenum box, damper blade and pressure tap (variant -MN) allow for volume flow rate balancing even with the diffuser face in place.

- Connect the measuring tube to the digital manometer
- Read the effective pressure
- Read the volume flow rate off the characteristic or calculate it
- If necessary, adjust the damper blade position with the cords

A characteristic is included with each AK-Uni plenum box.

AK-Uni-...-MN Volume flow rate balancing

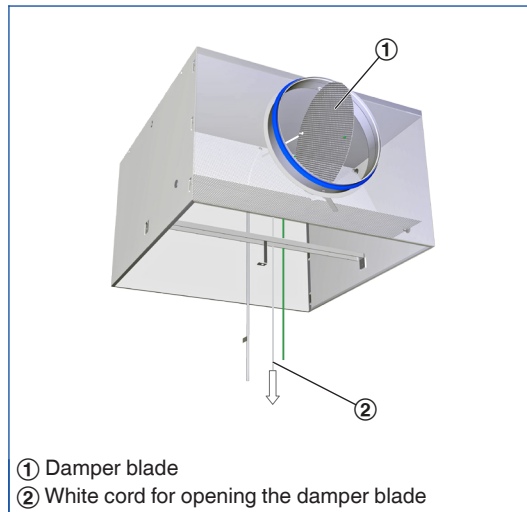

Open, 0°

AK-Uni-...-MN Volume flow rate balancing

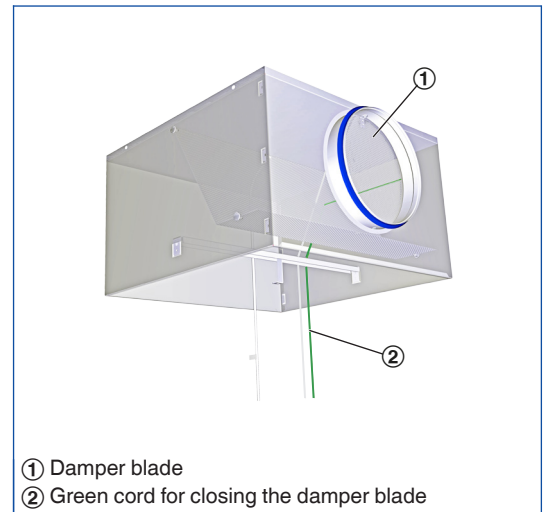

Closed, 90°

AK-Uni-...-MN volume flow rate measurement

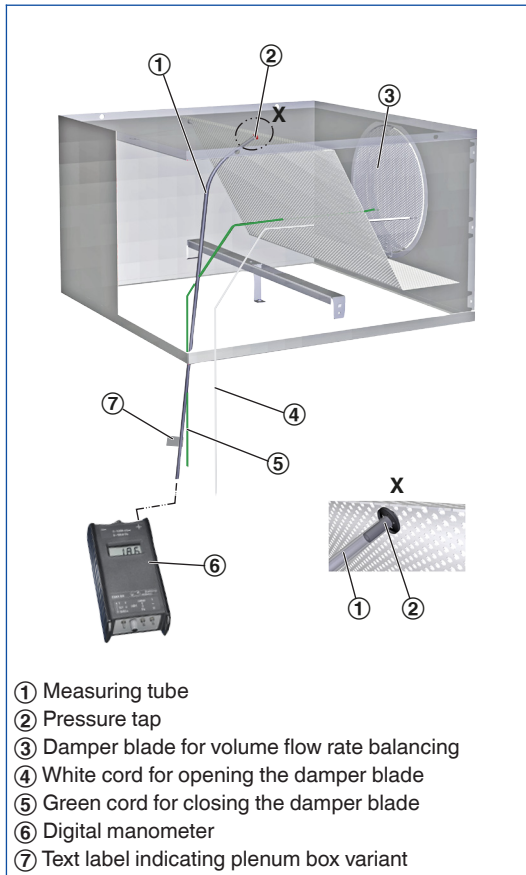

Volume flow rate calculation for air density
 1.2 kg/m^3

$$\dot{V} = C \times \sqrt{\Delta p_w}$$

Volume flow rate calculation for other air
densities

$$\dot{V} = C \times \sqrt{\Delta p_w} \times \sqrt{\frac{1.2}{\rho}}$$

Principal dimensions

$\varnothing D$ [mm]

Outer diameter of the spigot

$\varnothing D_1$ [mm]

Outer diameter of a circular diffuser face

$\varnothing D_2$ [mm]

Diameter of a circular diffuser face style

$\varnothing D_3$ [mm]

Diameter of a circular plenum box

$\square Q_1$ [mm]

Outer diameter of a square diffuser face

$\square Q_2$ [mm]

Dimensions of a square diffuser face style

$\square Q_3$ [mm]

Dimensions of a square plenum box

H_1 [mm]

Distance (height) from the lower edge of the

suspended ceiling to the lower edge of the diffuser face

H_2 [mm]

Height of a ceiling diffuser, from the lower edge of the suspended ceiling to the upper edge of the spigot

H_3 [mm]

Height of a ceiling diffuser with plenum box, from the lower edge of the suspended ceiling to the upper edge of the plenum box or of the spigot

A [mm]

Position of the spigot, defined by the distance of the spigot centre line to the lower edge of the suspended ceiling

C [mm]

Length of the spigot

m [kg]

Weight

Nomenclature

L_{WA} [dB(A)]

A-weighted sound power level of air-regenerated noise

\dot{V} [m^3/h] and [l/s]

Volume flow rate

Δt_z [K]

Supply air to room air temperature difference, i.e.

supply air temperature minus room temperature

Δp_t [Pa]

Total differential pressure

A_{eff} [m^2]

Effective air discharge area

All sound power levels are based on 1 pW.