

About Triton Systems

The company holds British Board of Agreement approvals and is a BS EN ISO 9001 Quality Assured Company. Triton was represented on the technical committee responsible for drafting British Standard BS 8102 (2009) – the Code of Practice for protection of below ground structures against water from the ground – and supplies systems and products to meet the requirements of all three methods of waterproofing as defined by the Standard.

To support architects, surveyors and contractors, a full programme of training courses has been created including three RIBA approved CPD seminars on basement waterproofing and green/living roofs. More details can be found at tritonsystems.co.uk/training

Concrete Waterproofing Systems – Integral Protection

The products described in this brochure are designed to be used in the construction of watertight concrete structures, typically new build and retrofit basements, underground car parks, swimming pools and lift pits. The range includes a unique chemical admix, systems for sealing construction joints and cable ducts, and products to make repairs. Triton also offers full system back up, including liaison with the concrete batching plant, mix design, construction joint detailing, site monitoring, repairs and warranty (where required).

Barrier Waterproofing

Triton also provides a range of products to achieve waterproofing that conforms to BS 8102 (2009) Type A – Barrier Protection. Further information can be found in Triton's brochure entitled 'Concrete Waterproofing Systems – Barrier Protection' which is available on request or can be downloaded at tritonsystems.co.uk

Cavity Drain Systems

Triton supplies a range of cavity drain membranes to achieve waterproofing that conforms to BS 8102 (2009) Type C. Please refer to the separate 'Cavity Drain Systems' brochure.

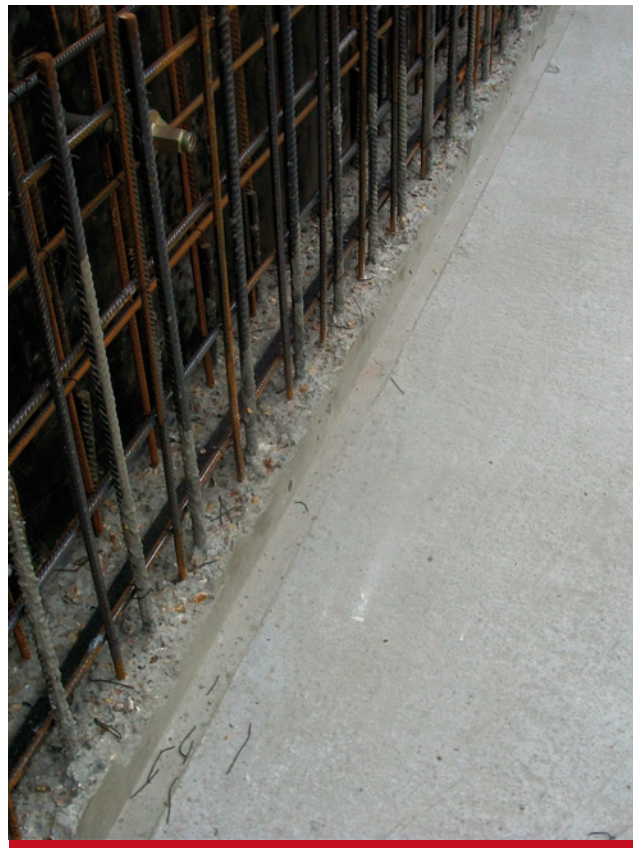

Available for download at tritonsystems.co.uk:
Material Safety Data Sheets for all Triton products
A comprehensive library of technical drawings

TRITON TT ADMIX

- Withstands extreme hydrostatic pressure (up to 12 bar)
- Increases durability
- Reduces shrinkage and cracking
- Protects concrete and steel from aggressive chemicals such as chlorides
- 10 year warranty available*

A unique chemical treatment for the waterproofing and protection of concrete, which is added to concrete at time of batching. The active chemicals in the TT Admix react with fresh concrete to generate insoluble crystalline growths, which seal the concrete against water penetration and protect the concrete against harsh environmental conditions. Packed as a dry powder compound, TT Admix consists of Portland cement, very fine treated silica sand and various active proprietary chemicals. The active chemicals remain active within the concrete.

Specification:

In accordance with NBS Specification J10 Cementitious Mortar Tanking/Damp Proofing. Type B Integral Protection in accordance with BS 8102 (2009)

Technical Data:

TT Admix is added to concrete at time of batching in dry powder form at a rate of 1.77% by weight of cement.

The concrete mix requirements for optimum performance of TT Admix requires a minimum cement content of 350kgs/m³.

The preference is for CEM1 (OPC), although a PFA** blend with a maximum 20% PFA content may be used. The maximum water : cement ratio is 0.5. For reference the use of GGBS (ground granulated blast furnace slag) is not permitted.

Alkali content: <0.1%, Chloride Ion < 0.05%.

For further information please refer to the 'Structural Waterproofing Data Pack – Type B Integral Protection' which is downloadable at tritonsystems.co.uk

* Warranty available on request subject to TT Admix monitoring scheme

** PFA – Pulverised Fuel Ash Cement Replacement

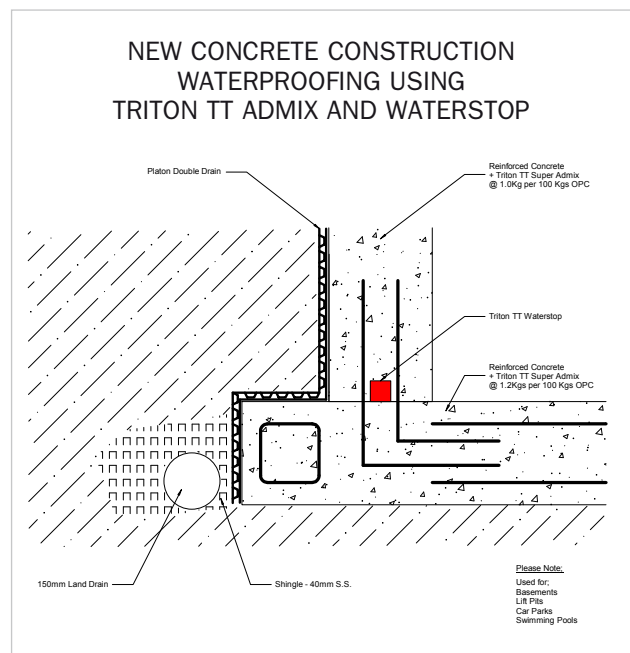

TRITON TT WATERSTOP

- Designed to seal poured in-situ construction joints
- Swells up to 350% when in contact with water
- Will withstand up to 40m head of water pressure
- Permanent water tight function

The use of Triton TT Waterstop and Triton TT Swellseal Mastic is a critical part of the TT Super Admix Watertight Concrete System. TT Waterstop is supplied as a 20mm x 25mm pre-formed waterstop in a ready to use roll. It has a built in delay system and the product activates after 2 days of exposure to water. Once activated, it will withstand up to 40m head of water pressure.

When fully encapsulated by poured concrete, the expansive forces form a seal against concrete surfaces. The seal resists hydrostatic pressure, stopping water from entering the sub-structures. TT Waterstop will return to its original size if the concrete and substrate is completely dry and re-expand if water or moisture is introduced again to the joints.

Specification:

In accordance with NBS specification E40 310 Designed joints in-situ concrete.

Technical Data:

Specific Gravity	1.35
Colour	Black
Tensile Adhesion Strength	> 30 kgf/cm ²
Volumetric Expansion Rate	>350%
Non-volatilization	99.7

NB Installation guidelines for TT Waterstop and TT Swellseal Mastic can be downloaded at tritonsystems.co.uk



1. Chase Cast in centre of wall section/joint section. Approximately 20mm x 15mm

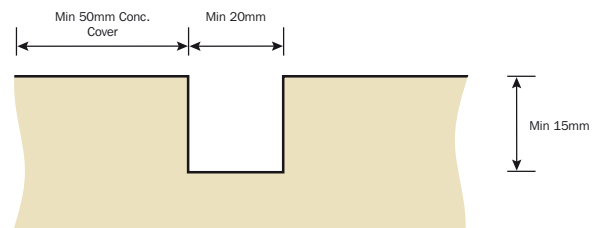

2. Min 10mm Bead TT Swellmastic to base of chase

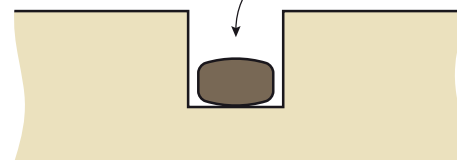

3. TT Waterstop adhered to chase of Swellmastic

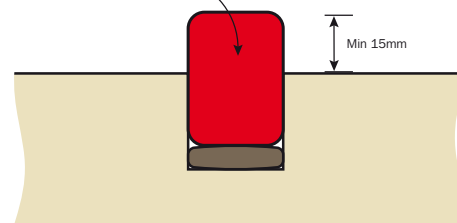

4. Joint option for TT Waterstop (within chase)

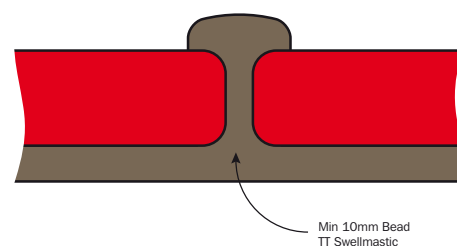

TRITON TT SWELLSEAL MASTIC

- Solvent free
- Excellent filling and adhesion properties

Triton TT Swellseal Mastic is a one part, ready to use hydro-reactive expansion mastic for the sealing of construction joints and around pipe penetrations. In contact with water Swellseal Mastic expands to around 350% of its original volume.

Specification:

In accordance with NBS Specification E40 530 Designed joints in-situ concrete.



Technical Data:

Property	Value	Norm
Solids	100%	Test DNC
Uncured		
Consistency	Gel / Paste	Test DNC
Density (at 20°C)	Approx. 1.45 kg/dm	DIN 53504
Slump in vertical applications	< 5mm (average 3mm)	Boeing test
Hand dry (at 20°C and 60% rel. humidity)	12 h	Test DNC
Flash Point	130°C	Pensky-Martens method
Cured (7 days at 25°C, 10mm thick)		
Elongation at break	Approx. 625%	DIN 53504
Tensile Strength	Approx. 2.2 N/mm	DIN 53504
Resistance to hydrostatic pressure column	Up to 150 metres of water	Test DNC
Swelling capacity in contact with water	Swells to approx. 350% of its original dry volume	Test report KUL University

NB Installation guidelines for TT Waterstop and TT Swellseal Mastic can be downloaded at tritonsystems.co.uk

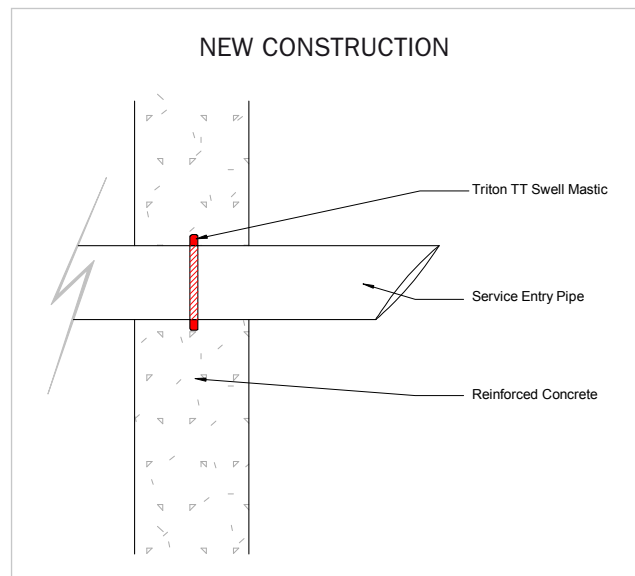

TRITON INJECTION TUBE

- Simple installation
- Can be injected with all known resins
- Repeated injection possible

Triton Injection Tube is designed for waterproofing construction joints in new and existing structures and specifically for the multiple injection of suitable grouts into construction joints and other areas that may require injection at a later date. The tube can be placed in lengths of 10 – 30 metres.







The tube is placed between the reinforcement bars or along the interface joints of concrete slabs and is held in place using special clips to ensure it remains in place even during concrete pouring. Injection points are normally placed through the formwork to provide easy access when injection is required.

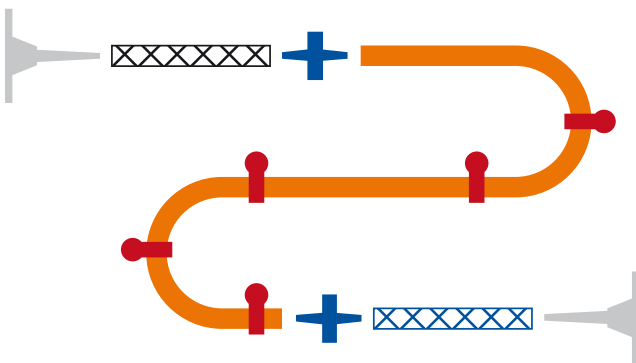

Technical Data:

Colour	Orange
Size	Internal 5-6mm External 12mm
Construction	Virgin PVC
Slot length	4mm
Toxicity	Non-Toxic



	Shutter Connector
	Hose Connector
	Hose Fixing Bracket
	Inlet Hose
	Outlet Hose
	Injection Hose

REPAIRS USING TRITON TT SUPER, TRITON FILLET SEAL AND TRITON QUICK SET

Following the placement, curing and compaction of Triton TT Super Admix watertight concrete, upon removal of the formwork and exposing of the placed concrete, a visual inspection is required. If honeycombing or leaks to the construction joints are identified then repairs can be made using Triton TT Super (barrier waterproofing system), Triton Fillet Seal and Triton Quick Set plugging compound. Further information is provided in the 'Structural Waterproofing Data Pack BS 8102 (2009) – Type B Integral Protection' which can be downloaded at tritonsystems.co.uk



Construction joint repair using Triton Fillet Seal.

SEALING CABLE DUCTS USING TRITON QUICK SET, TRITON 190 RESIN AND TRITON TT55

Triton offers a complete system of products for sealing cable ducts in below ground structures and/or areas prone to flooding. Please refer to the 'Sealing Cable Ducts Data Pack' which can be downloaded at tritonsystems.co.uk for more detailed information on how to seal cable ducts.

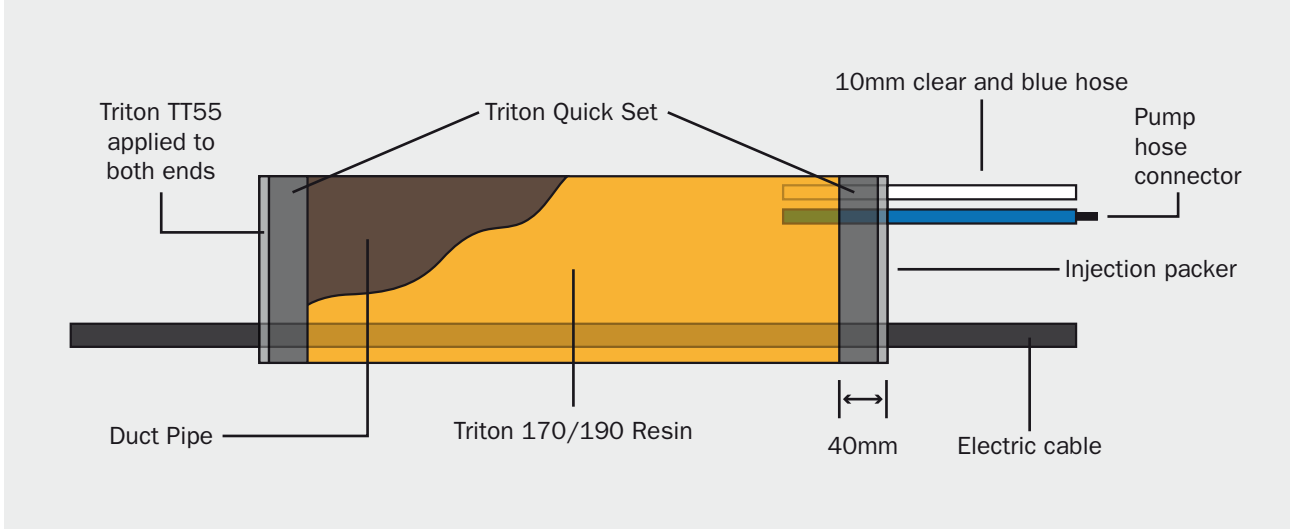



Guarantees

Triton approved contractors have access to TUG Insurance Backed Guarantees which are issued for a maximum of 30 years and which cover wall tie replacement, below ground waterproofing and damp and timber treatment. The TUG Insurance Backed Guarantee provides peace of mind to clients by coming into force in the event of the approved contractor ceasing to trade.

Triton also issues its own guarantees to cover the performance of Triton products plus the workmanship of the Triton Approved Contractor. These are designed for contractors who do not issue their own company guarantees. Triton Guarantees are valid for up to 30 years from date of completion of the works (up to 10 years for below ground waterproofing).

Visit www.tug.uk.com to apply for Triton Approved Contractor status and to download the guarantee application forms.



Also available from Triton

- Flooring Systems (gas barriers, waterproofing and damp control)
- Flood Resilience/Restoration
- Replacement Cavity Wall Ties
- Damp Proofing and Replastering Systems
- Protective Coatings, Structural Repair
- Timber Preservation and Repair
- Green Roof Systems
- Radon (ground gas) Barrier Systems
- Concrete Waterproofing – Type A
- Condensation Control Systems
- Cavity Drain Systems



Triton Systems

Units 3 – 5 Crayford Commercial Centre, Greyhound Way, Crayford, Kent DA1 4HF
Tel: 01322 318830 Fax: 01322 524017 Email: info@tritonsystems.co.uk

Triton Chemical Manufacturing Co Ltd trading as Triton Systems