



Qbiss.One

Qbiss One

SPECIAL SOLUTIONS

CONTENT

1.0 FACADE ELEMENT [1]

- 1.1 New architectural possibilities / Qbiss One FB / Qbiss One BF [1]
- 1.2 ArtMe [3]
- 1.3 Curved elements [4]
 - 1.3.1 Transversal curved [4]
 - 1.3.2 Longitudinal curved [5]
- 1.4 Non orthogonal elements (trapezoidal/parallelogram) [6]

2.0 CORNERS [7]

- 2.1 Transversal corner element [7]
 - 2.1.1 Classical - combining of two elements [7]
 - 2.1.2 Under an angle - combining of two elements [8]
- 2.2 Longitudinal corner element combined [9]
 - 2.2.1 Classical - combining of two elements (shape and colour combination) [9]
 - 2.2.2 Under an angle - combining of two elements [10]
- 2.3 3D corners [11]

3.0 WINDOWS/DOORS/CURTAIN WALLS [12]

- 3.1 Windows, Doors and Curtain walls integration [12]

1.0 FACADE ELEMENT

1.1 New architectural possibilities / Qbiss One FB / Qbiss One BF

Qbiss One FB-transversal joint recessed, longitudinal joint flush

Basic Qbiss One B system is different only in respect of its longitudinal male joint, which is more narrow, 4 mm to achieve a flush look. The transversal joint stays recessed, 25 mm wide.

Fig. 1.1: TRANSVERSAL and LONGITUDINAL joint of both horizontal installation methods

Transversal joint

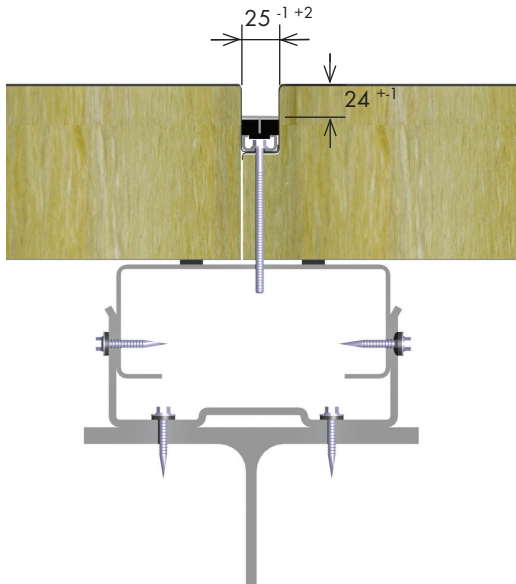

Transversal joint dimensions: 25 mm x 24 mm

Longitudinal joint

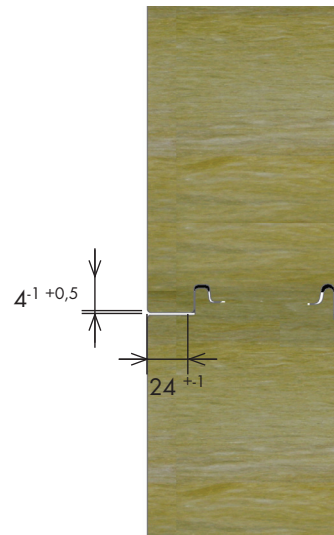

Longitudinal joint dimensions:
4 mm x 24 mm

Fig. 1.2: Facade element QO B - Horizontal installation

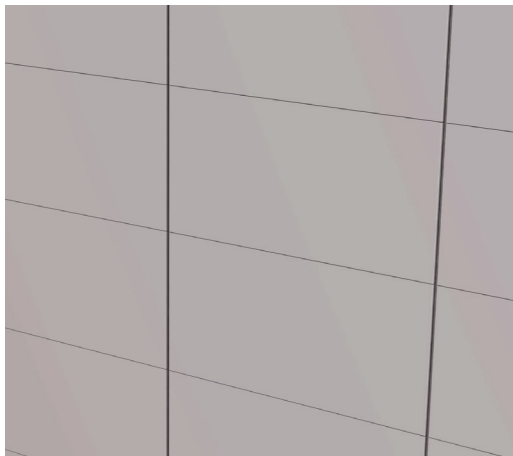

Fig. 1.4: Facade element combination QO FB + B - Horizontal installation

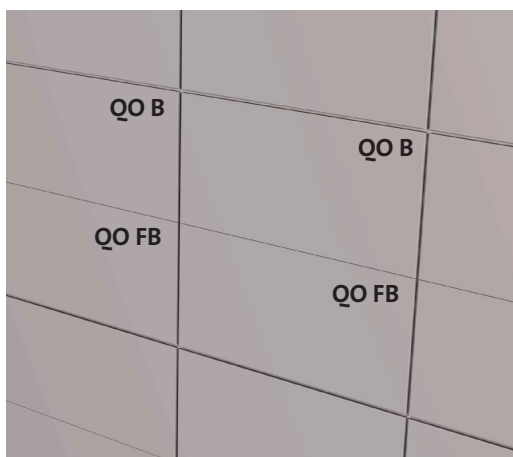

Fig. 1.3: Facade element QO B - Vertical installation

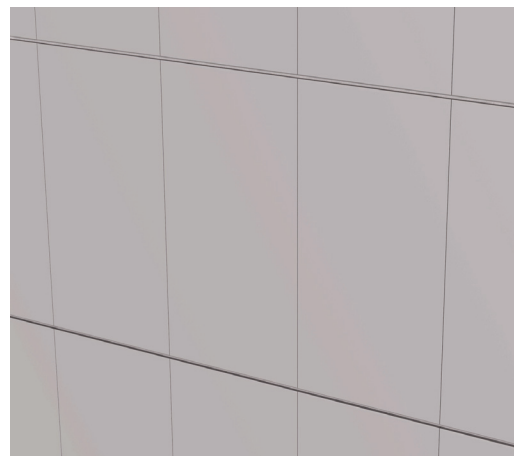
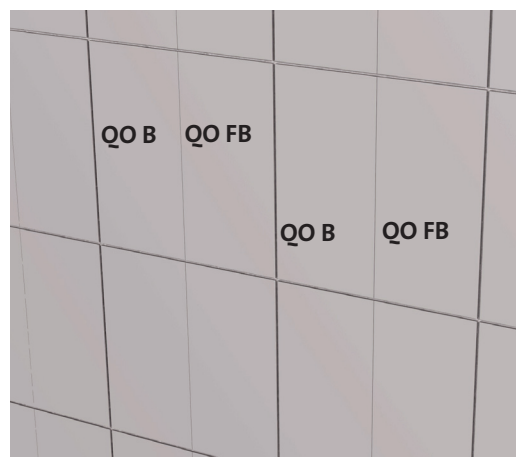

Fig. 1.5: Facade element combination QO FB + B - Vertical installation



Qbiss One BF - transversal joint flush, longitudinal joint recessed

Basic Qbiss One B system is different only in respect of its transversal joint where the T-profile is extended to the outer surface to achieve a flush appearance. The longitudinal joint stays recessed, 23 mm wide and 24 mm deep.

Fig. 1.6: TRANSVERSAL and LONGITUDINAL joint for both horizontal installation methods

Transversal joint

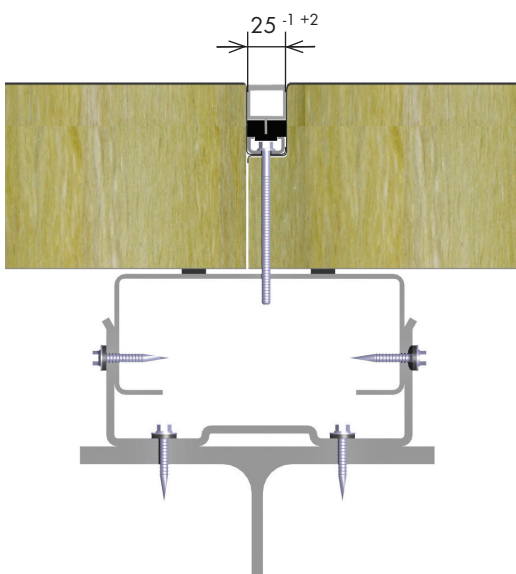

Transversal joint dimensions: 25 mm

Longitudinal joint

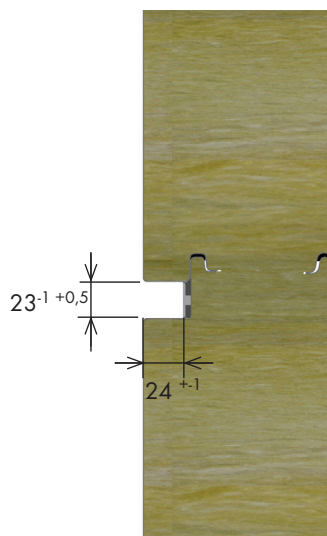

Longitudinal joint dimensions:
23 mm x 24 mm

Fig. 1.7: Horizontal installation

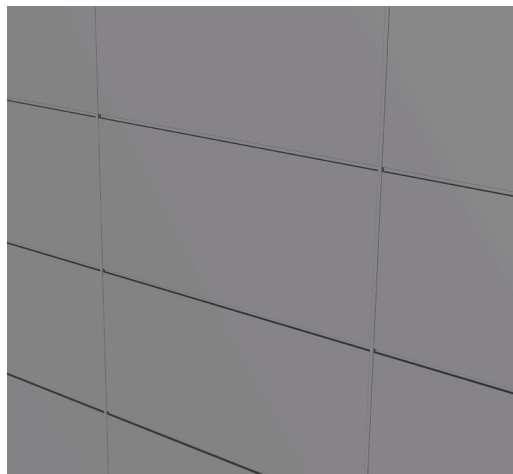
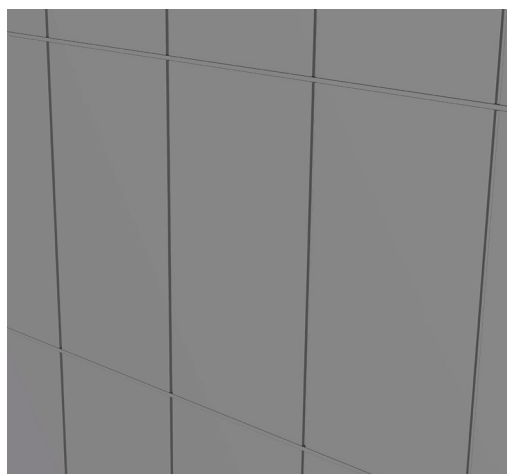

Fig. 1.8: Vertical installation



1.2 ArtMe

ArtMe individuality can be achieved by the continuously 3D mechanical transformation of the element surface or figuratively “by drawing” on the element.

Two options are available:

Option 1: using **pre-designed** patterns (3)

Option 2: preparing **individual designs** at the request of a customer

ArtMe offers 3 basic pre-fabricated designs or the components that can be optionally combined. These designs, **Concept 1** are marked as »bubbles«, »curves« and »puzzles«.

An advantage of this concept is that it is already tried-and-tested, has optimized **statics** and enables **quick** and **less expensive assembly**.



Concept 2 requires **pattern confirmation with the** Trimo expert team.



Possibilities

- ArtMe designs can be applied only to FLAT SURFACES
- max. 6.5 m length of the base element
- material thickness 0.7 mm
- steel sheet coatings: PVDF, PUR
- mechanical properties of the element can change by applying design (should be checked in advance with Trimo expert team)
- offset from base element surface edge: Qbiss One 30 mm

Fig. 1.9: Poznan Stadium, Poland



Fig. 1.10: Blackburn Central High School, GB



1.3 Curved elements

1.3.1 Transversal curved

Possibilities:

- Radius - r [m]: minimal 4 m and more
- Thickness - S [mm]: 80 - 240
- Length - R [m]: up to 4 m
- Form: Convex & Concave
- Performance: retained thermal insulation, fire resistance, sound insulation
- Consultancy: for each project with necessarily data (r , S , R project performance demands)

NOTE:

All applications for use must be approved by Trimo's technical support.

Fig. 1.11: Curved elements

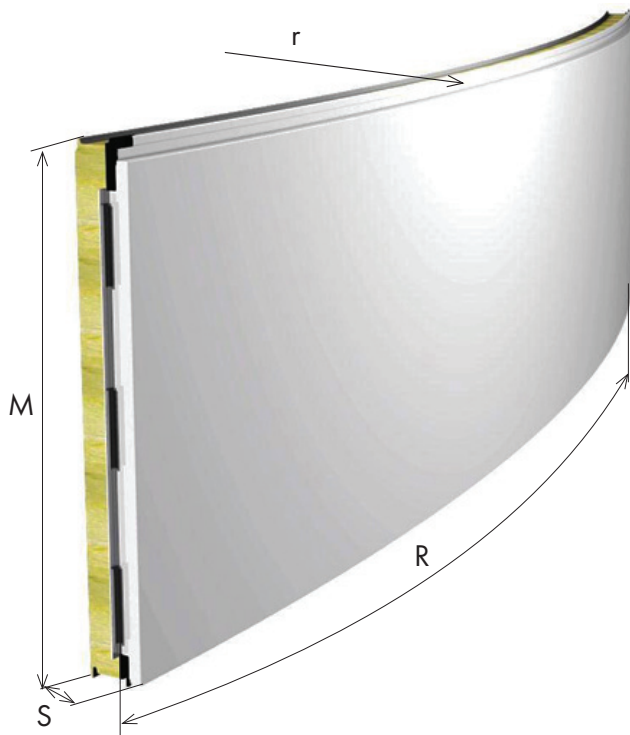

Fig. 1.11a: Curved elements - Convex

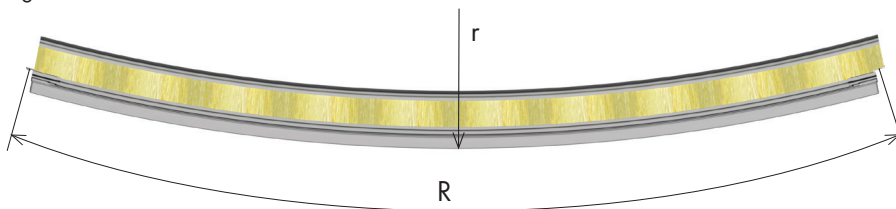
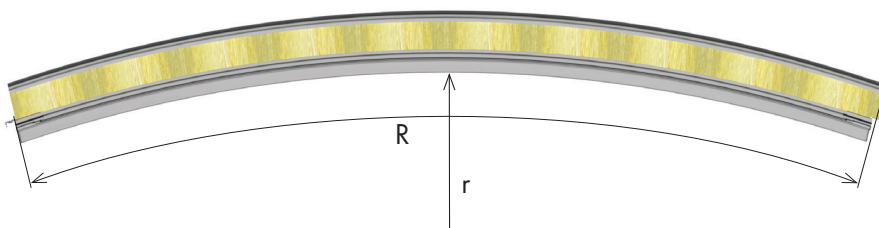

Fig. 1.11b: Curved elements - Concave



1.3.2 Longitudinal curved

Possibilities:

- Radius - r [m]: minimal 4 m and more
- Thickness - S [mm]: 80 - 240
- Length - R [mm]: 530 - 5700
- Form: Convex & Concave
- Performance: retained thermal insulation, fire resistance, sound insulation
- Consultancy: for each project with necessarily data (r , S , R , project performance demands)

NOTE:

All applications for use must be approved by Trimo's technical support.

Fig. 1.12: Curved elements

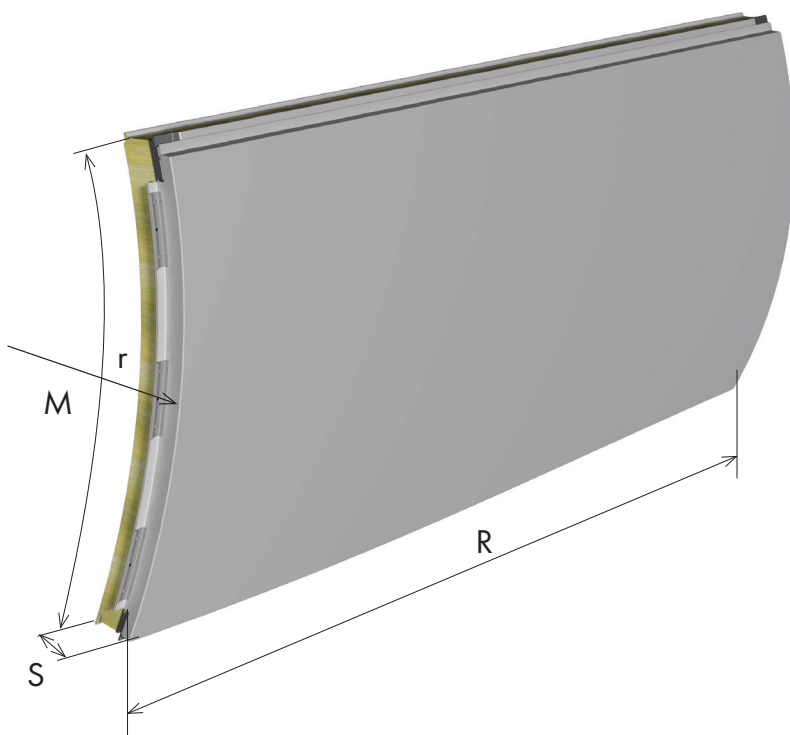
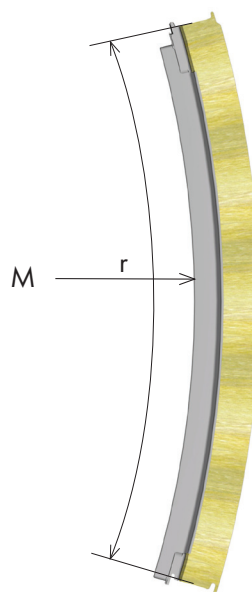
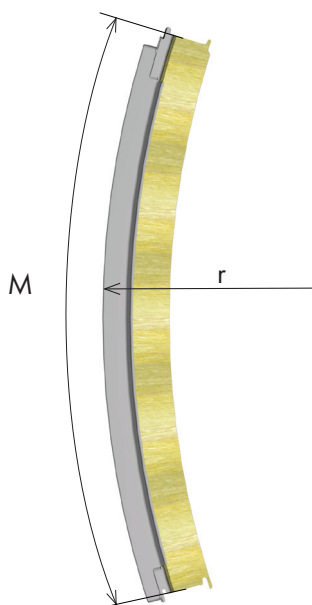

Fig. 1.12a: Curved elements - Convex

Fig. 1.12b: Curved elements - Concave



1.4 Non orthogonal elements (trapezoidal / parallelogram)

Elements of non orthogonal shapes are facade elements with one or two angled transverse sides - longitudinal joints (male/female) are parallel.

NOTE:

All applications for use must be approved by Trimo's technical support.

Fig. 1.13: Horizontal installation



Fig. 1.14: Non orthogonal elements (trapezoidal / parallelogram)

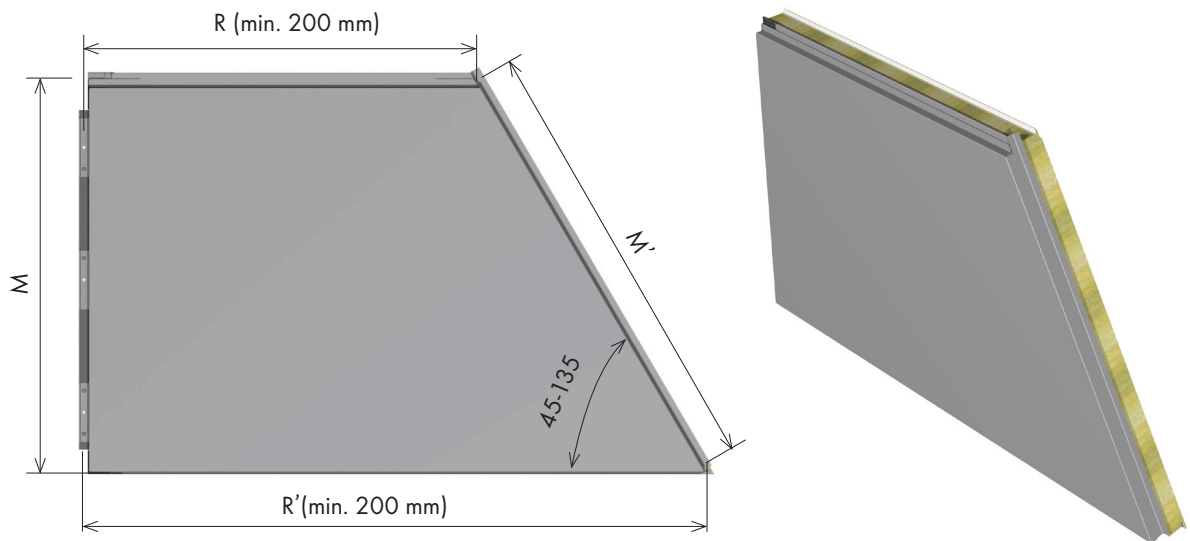
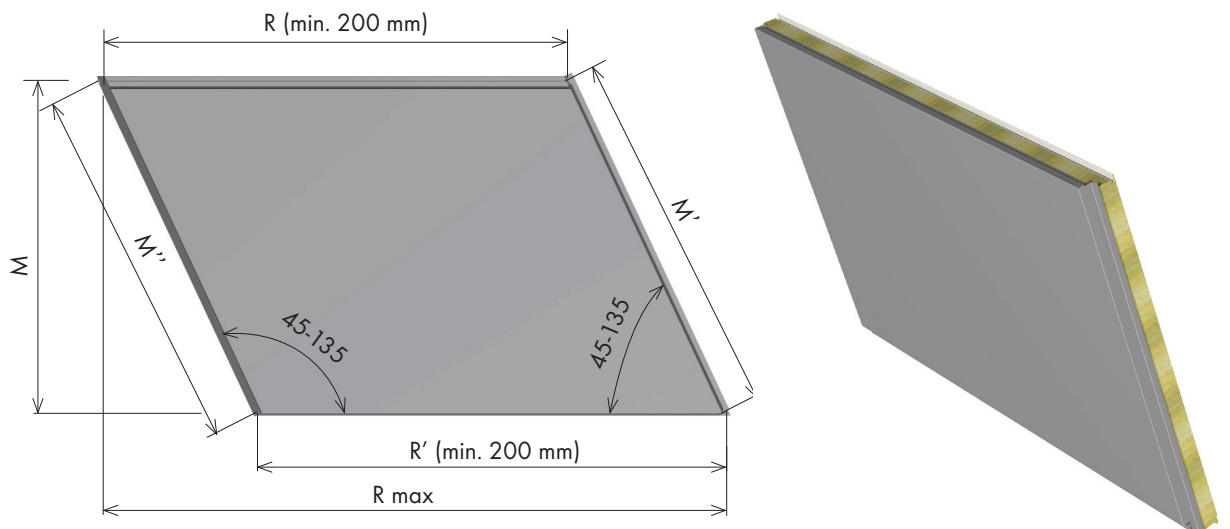

Fig. 1.15: Non orthogonal elements-two angled transverse sides



2.0 CORNERS

2.1 Transversal corner element

2.1.1 Classical - combining two elements

Possibilities:

- Combining two different colours
- Element thickness S [mm]: 80 - 240
- Module width M [mm]: 600 - 1200
- Minimal leg length [mm]: $A_{\min} = B_{\min} = s + 150$ mm (* Qbiss One B/F $A + B = \min. 530$ mm)
- Maximal leg length [mm]:

A+B (max) = 2000 mm

Amax= 1000 mm; Bmax= 1000 mm

Amax= 900 mm; Bmax= 1100 mm

Amax= 800 mm; Bmax= 1200 mm

Amax= 700 mm; Bmax= 1300 mm

A+B (max) = 4100 mm

Amax= 600 mm; Bmax= 3500 mm

Fig. 2.1: L corner shape

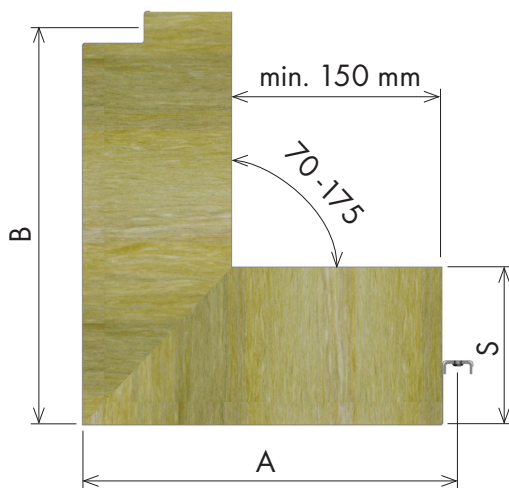
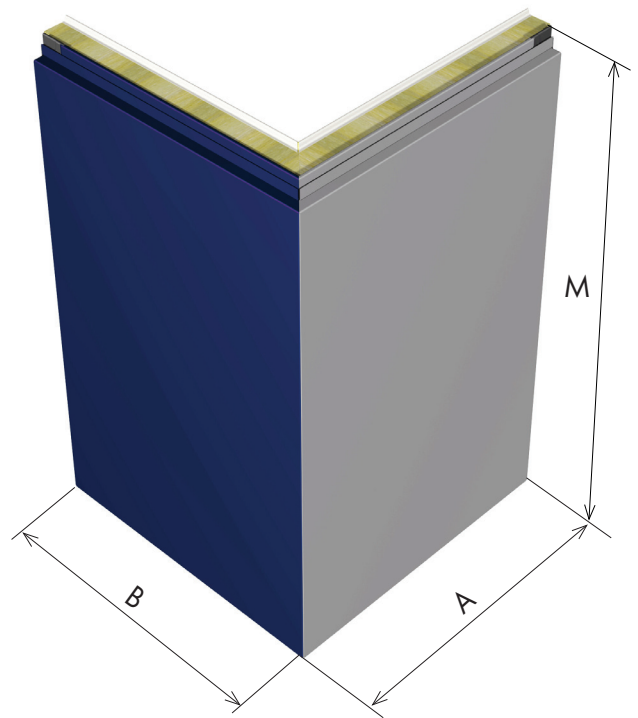

Fig. 2.2: Combination of two different colours



2.1.2 Under an angle - combining two elements

Possibilities:

- Under an angle
- Combining two different colours

NOTE:

All applications for use must be approved by Trimo's technical support.

Fig. 2.3: L corner shape - angled transverse sides

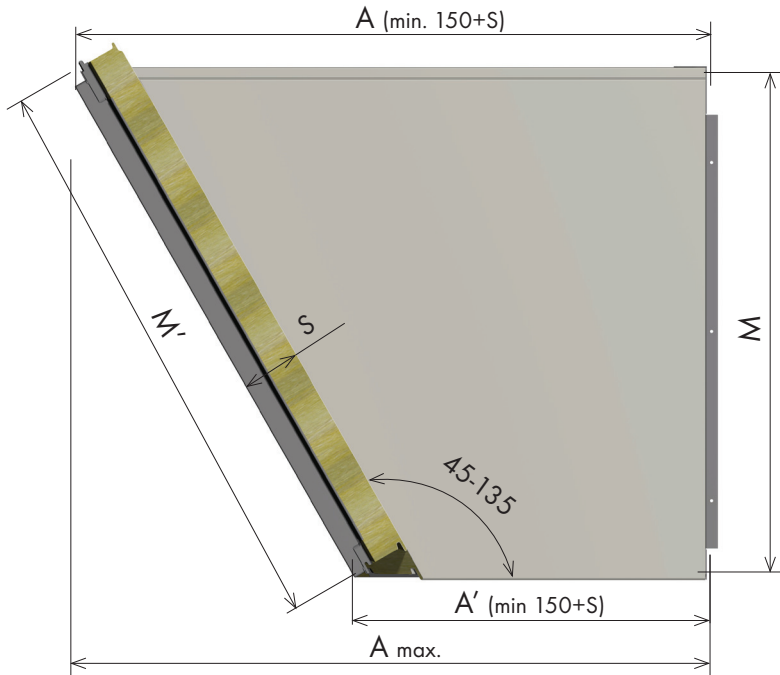
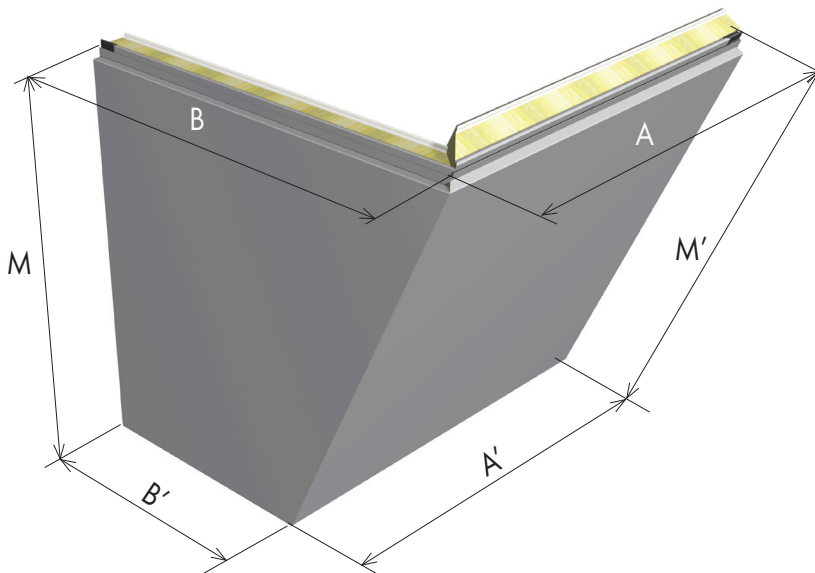

Fig. 2.4: L corner shape - angled transverse sides



2.2 Longitudinal corner element - combined

2.2.1 Classical - combining two elements (shape and colour combination)

Possibilities:

- Combining two different colours
- Element thickness S [mm]: 80, 100, 120, 133, 150
- Module width M [mm]: 600 - 1200
- Minimal leg length [mm]:
 - $A_{\min} = 150$ (200)
 - $B_{\min} = 200$ (150)
 - $A+B = \text{min. } 600 \text{ mm}$
- Maximal leg length:
 - $A_{\max} = B_{\max} = 800 \text{ mm}$ & $A+B = \text{max. } 1600 \text{ mm}$
 - Element length R [mm]: 530 - 6500
- Angle between legs $70^\circ - 175^\circ$

Fig. 2.5: L corner shape

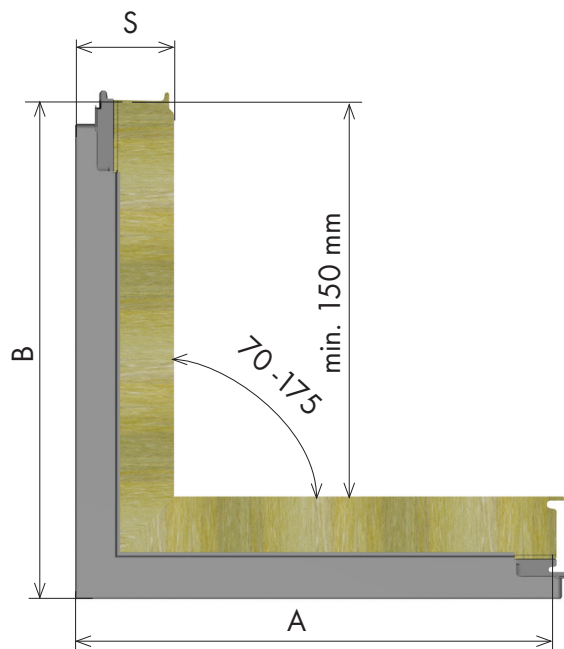
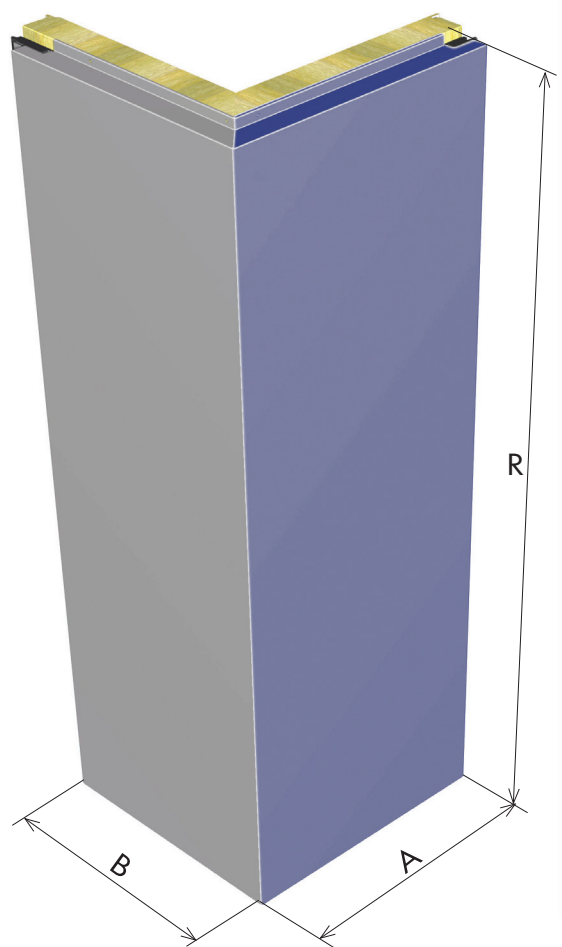

Fig. 2.6: Combination of two different colours



2.2.2 Under an angle - combining two elements

Possibilities:

- Under an angle
- Combining two different colours

NOTE:

All applications for use must be approved by Trimo's technical support.

Fig. 2.7: L corner shape

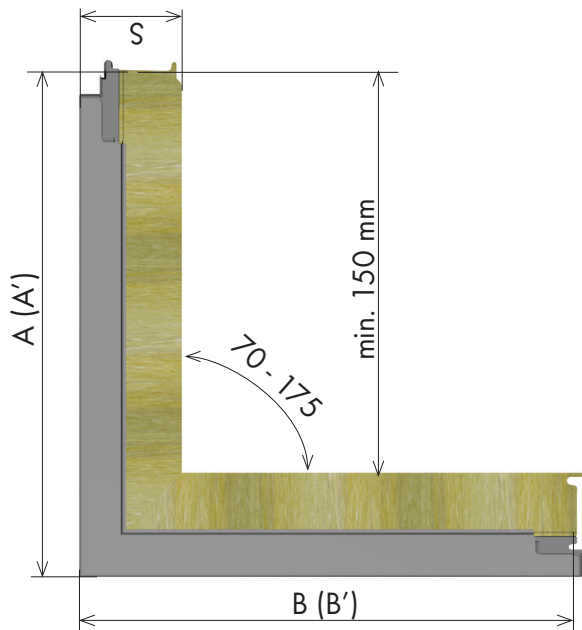
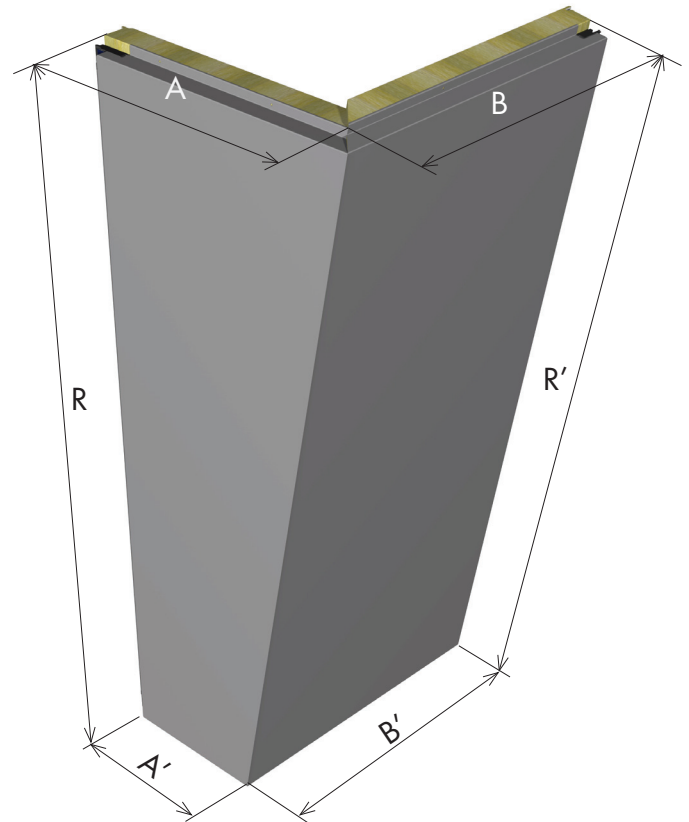

Fig. 2.8: Corner under an angle



2.3 3D corner

3 D corner was developed such that one Qbiss One corner element is laid horizontally and folded below 45° angle in the transversal direction. This allows the façade to pass smoothly into a soffit in one piece.

NOTE:

All applications for use must be approved by Trimo's technical support.

Fig. 2.9: 3D corner under an angle

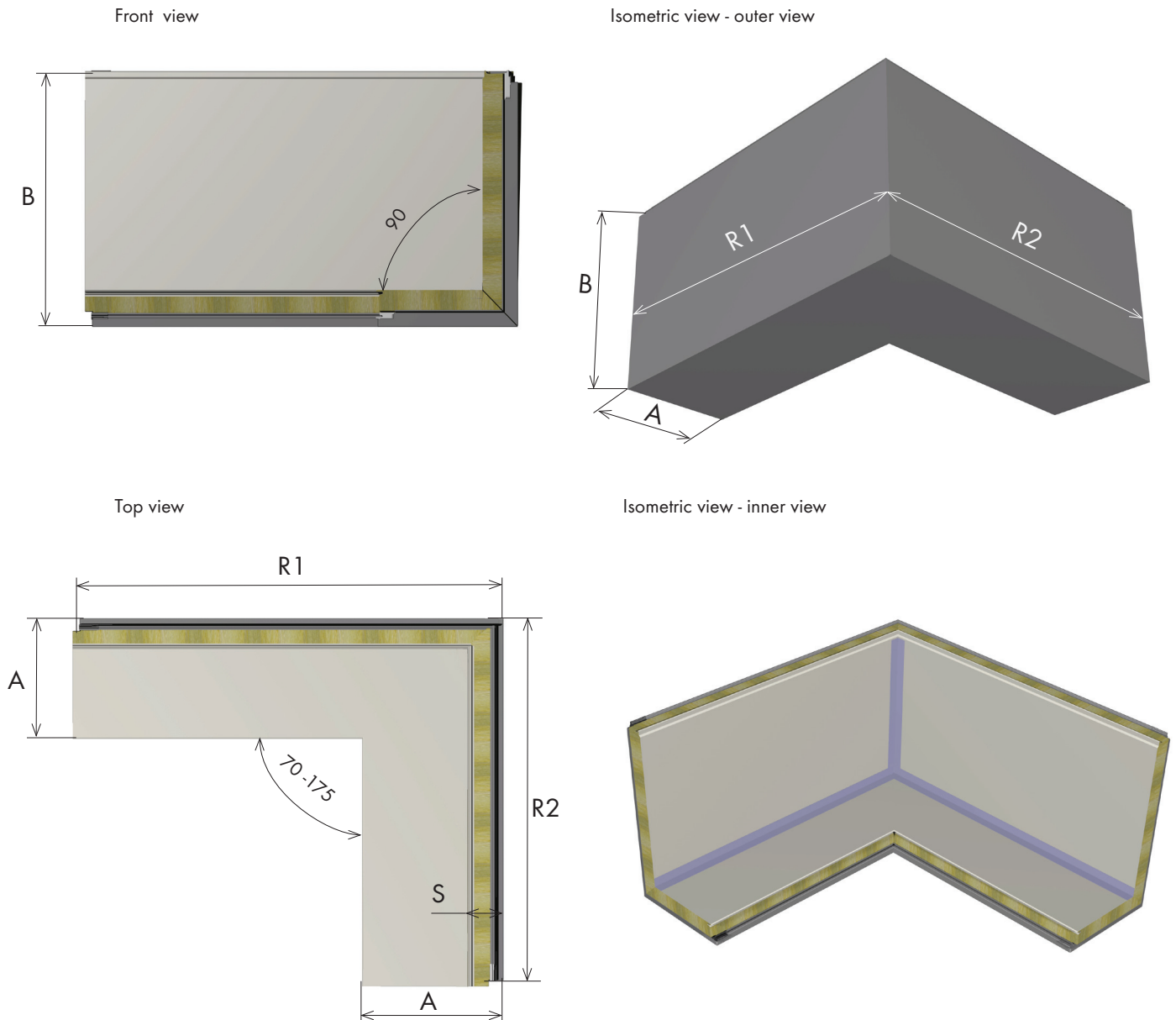

3.0 WINDOWS/DOORS/CURTAIN WALLS

3.1 Windows, Doors and Curtain walls integration

Qbiss modular façade system offers a range of elegant and high-quality solutions for windows, doors and other openings. Frames are made of aluminium profiles with an integrated thermal transfer barrier that assures thermal stability of the indoor environment. They enable a quick assembly of openings and efficient replication of façade details. The modular assembly system allowse of the following types of frames and windows.

WINDOW AND DOOR OPENINGS

Types (feasible assembly combinations: A, B, C):

TYPE 1 equal to façade element dimension

Type 1.1 - visible joint

Type 1.2 - visible joint by shift

TYPE 2 not in element dimension

Type 2.1 - with covered edges, windows smaller than element

Type 2.2 - with covered edges, windows larger than element

Combinations of window and glazings

A - Aluminium frame (blind frame)

B - Aluminium frame + fixed glazing

C - Aluminium frame + glazing with opening function

Fig. 3.1: TYPE 1 - in element dimension

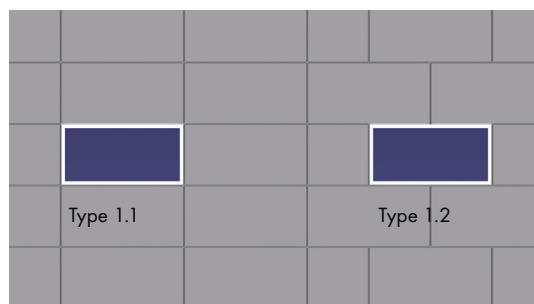
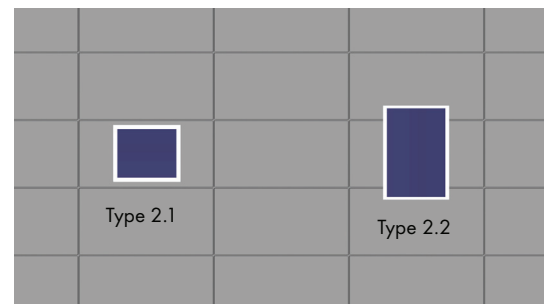

Fig. 3.2: TYPE 2 - not in element dimension



NOTE:

- Supporting sub-structure for the location of openings must be defined by static calculation.

Qbiss One facade system enables integration with different Windows, Doors and Curtain Walls systems that are available on the market.

For more information please contact Trimo's technical support, tech.info@trimo.si.

Trimo, d. d.,

Prijateljeva cesta 12,
8210 Trebnje, Slovenia

t: +386 (0)7 34 60 137

f: +386 (0)7 34 60 127

e: qbiss@qbiss.eu

w: www.qbiss.eu, www.trimo.eu

