



Natural Lighting by Monodraught



Universal Installation Instructions

Preparation and Safety Information

Scaffolding

For flat roofs and single storey buildings not exceeding 10 ft. (3 m) in height, access to the roof can be gained by ladder, but caution should be taken to prevent any falling materials. For two-storey buildings and pitched roofs a tower scaffold or similar should be provided to gain access to the roof if it is greater than 10 ft. (3 m) in height from ground level and not more than 20 ft. (6 m) in height. For access to roofs greater than 20 ft. (6 m) in height a professionally installed scaffold access should be provided. All scaffolding and ladders must be properly fixed to the building and all necessary precautions must be taken to prevent falling materials and provide a safe working environment for personnel.

Electricity

Normal safety precautions should always be followed. A low voltage power supply should be used when appropriate. Care should be taken to ensure there are no wires, cables, leads, water or gas pipes near the work area. Suitable eye protection and protective gloves must be worn.

Cutting

SUNPIPE tubes can be sharp after their ends are cut with tin snips, protective gloves must be worn.

Dust

A safety mask should be worn to ensure you don't inhale dust when carrying out the installation of a SUNPIPE system.

Other safety recommendations

Don't fit SUNPIPE when it is raining or the roof area is wet or slippery.

You will need the following equipment

Protective eye-wear, protective gloves, protective breathing mask, ladders, tin snips, power drill, power jig-saw, dispensing gun to dispense the silicone sealant supplied, pad saw, stanley knife, miscellaneous other tools.

Building Regulations

Always check with your local council that your installation complies with all local Building Authority requirements.

Contents

Flat Roof SUNPIPE

Components for a Standard Kit installation of a Flat Roof SUNPIPE System

Interior Preparation

Exterior Preparation

Installing the Foam Inserts

Fitting the Flashing Plate

Fitting the Collar

Assembling the Pipe

Assembling the Elbow Pipes

Fitting the First Pipe

Fitting the Dome

Fitting Additional Extension Pipes and Bends

Fitting the Ceiling Diffuser

Pitched Roof SUNPIPE

Components for a Standard Kit installation of a Pitched Roof SUNPIPE System

Before You Start

Insufficient Space Between Joists

Best Location for a SUNPIPE

Different Roof Types

External Preparation

Positioning the SUNPIPE

Removing the Tiles/Slates

Fitting the ABS Under-Cloak

3 Installing the Flashing Plate on a Slate Roof **12**

3 Installing the Flashing Plate on a Tiled Roof **12**

4 Foam Weathering Installation (I) **13**

4 Foam Weathering Installation (II) **14**

5 Fitting the Collar **14**

5 Fitting the First Pipe **14**

6 Notes on Internal Arrangements for All Pitched Roof Installations **15**

6 Installation of Rooflight **16**

6 Fireguard Ceiling Diffusers **16**

7 **Optional Accessories** **17**

7 Light Kit Fitting Instructions **17**

8 Motorised Light Shut-Off Damper **17**

8 **Suncatcher & Additional Features** **18**

9 Flat Roof **18**

9 Pitched Roof **18**

9 Assembling the SUNPIPE and Top Dome **19**

10 Installing the Galvanised Ceiling Transition **19**

10 Installing the SUNPIPE Components and Flexible Ventilation Ducting **19**

10 Installing the Prismatic Diffuser and Ceiling Bezel **19**

10 Suspended Ceilings Commercial SUNPIPES **20**

11 Protective Film **20**

12 **Information** **21**

21 Frequently Asked Questions **21**

21 Addendum **22**

22 Maintenance **22**

22 When the Installation is Complete **22**

22 Installation Notes **23**

Flat Roof SUNPIPE

Components for a Standard Kit installation of a Flat Roof SUNPIPE System

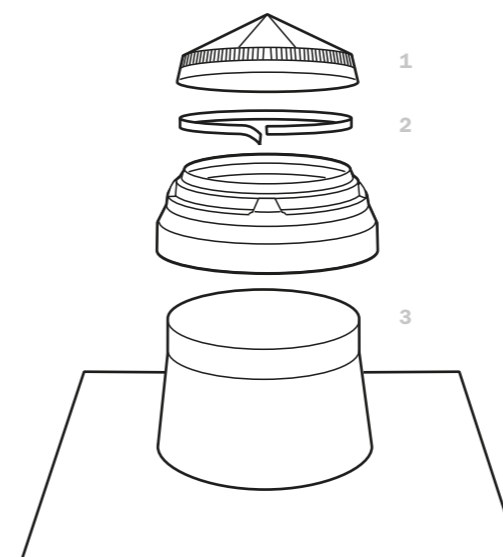

- 1. Diamond Dome**
High impact acrylic roof dome
- 2. Brushed nylon condensation seal**
- 3. ABS or Galvanised flashing plate and collar**
For use with plain and slate tile flat roofs
- 4. Plain end SUNPIPE 610 mm**
Straight length of SUNPIPE SUPER- SILVER Aluminium Tubing. Must be used to terminate above ceiling level.

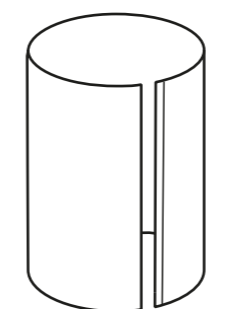

- 5. 3 mm Plywood Backing Plate**
Template for marking ceiling opening and additional ceiling support

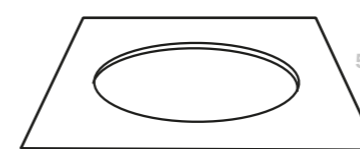

- 6. Fixing Ring**
Housing for diffuser components secured to the ceiling



- 7. SUNPIPE Slip Length**
Final length of SUNPIPE at ceiling level

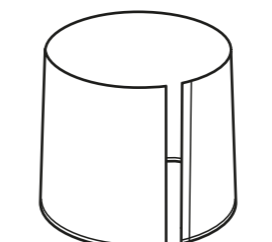

- 8. Micro Prism Ceiling diffuser**
Double glazed ceiling diffuser designed for best dispersion of natural daylight



- 9. Clip on Diffuser Trim**
White ABS diffuser fascia

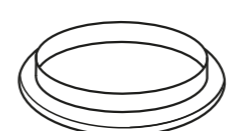

Optional Additional Components

610 mm Extension length with crimped end

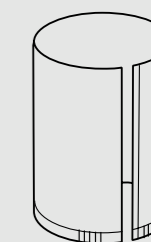

30° Adjustable Elbow
Used where a small offset is required

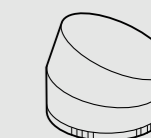

45° Adjustable Elbow
Used where a large offset is required

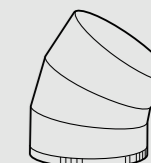

Alternative Components

Green Roof Application
Height of cone will vary according to each build

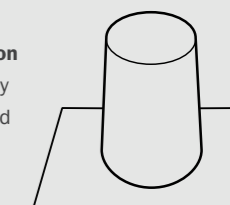

Installation Pack

- 6 x 35 mm or 45 mm Screws (depending on SUNPIPE size)
- 10 x Black Washers
- Silver Aluminium Tape
- Silicone Sealant

Interior Preparation

Tips for Finding Joists

Some flat roofs have a ventilation gap, just behind the fascia board running along the edge of the roof. The joist positions can be seen through the gap. Use a stud finder if possible.

Marking Out Your SUNPIPE Exit

Drill a small pilot hole in the centre of the position of your SUNPIPE. Use this to determine whether there is sufficient clearance within the ceiling space. You may have to adjust the centre point of the SUNPIPE so there is no need to cut the joists.

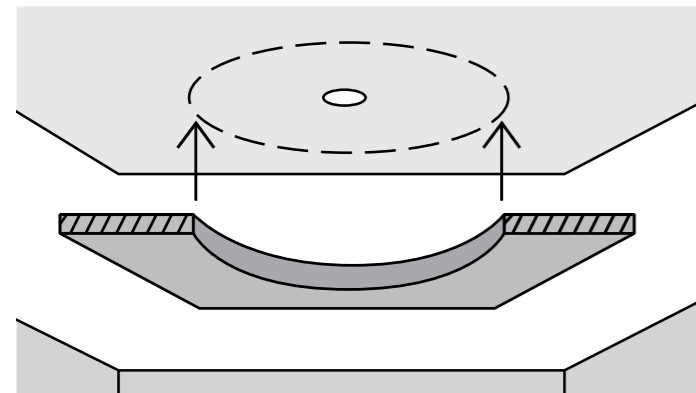

Use the 3 mm plywood backing panel as a marking out template (see diagram above). Carefully check there are no adjacent power or other services nearby, then enlarge hole as necessary.

Cutting Sizes

Enlarge the hole to the sizes shown in the table below.

Nominal [mm]	SUNPIPE Diameter	Actual Diameter	Hole Size to Cut Ø
230	9"	230 mm	240 mm
300	12"	305 mm	315 mm
450	18"	458 mm	470 mm
530	21"	536 mm	550 mm

Note: The plywood backing panel is not provided for 750 mm, 1000 mm and 1500 mm.

Nominal [mm]	SUNPIPE Diameter	Actual Diameter	Hole Size to Cut Ø
750	30"	762 mm	780 mm
1000	40"	1000 mm	1030 mm
1500	60"	1500 mm	1530 mm

Insufficient Space Between Joists

If there isn't sufficient space, as a guide, on a 'cut roof', one rafter and ceiling joist may be cut to allow installation of your SUNPIPE. However, cross trimmers between adjacent rafters or ceiling joists must be installed at each side of the openings to support the 'cut' ends.

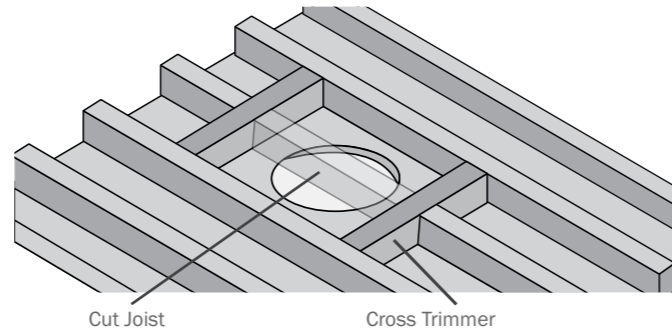

Under no circumstances should any element of a structured timber or beam be cut without prior clearance from a structural engineer.

Exterior Preparation

Establish whether your flat roof is safe to walk on

If it isn't, prepare your 'duck boards' so that you can work safely

Marking out your SUNPIPE Entrance

Drive a screw from the internal void through the roof membrane to mark the centre point or roof opening.

Place the flashing plate centrally over the pilot hole. Mark the perimeter of the square skirt on the roof with chalk.

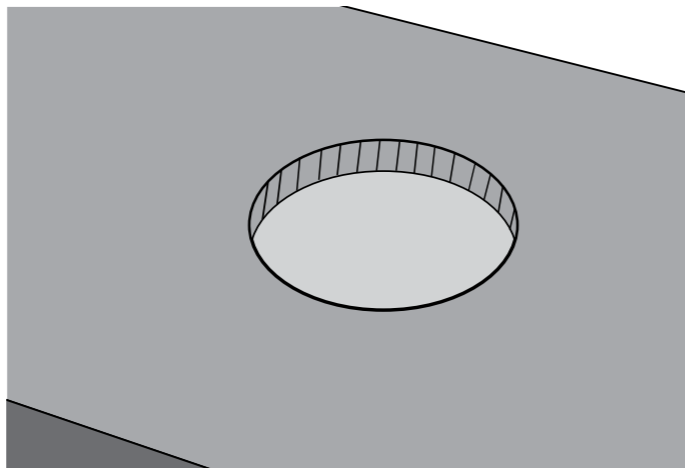

Creating Your SUNPIPE Entrance

Use plywood template to mark at roof level and cut a circular hole through the roofing board material (see diagram above). Ensure the hole aligns with the hole in the ceiling below.

Installing the Foam Inserts

Please ensure flashing plate is temporarily weathered until SUNPIPE system is installed



Bring edges of the foam together to form a circle. (Angled face touching ABS upstand.)



Fit into place from the underside of the ABS upstand

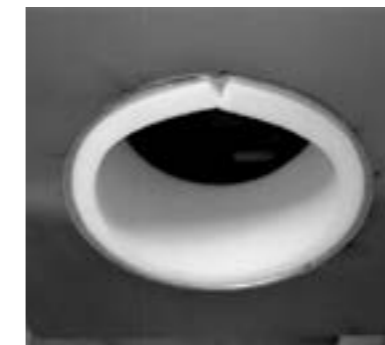

Invert ABS upstand and ensure foam is flush with the underside base prior to installation.

Fitting the Flashing Plate

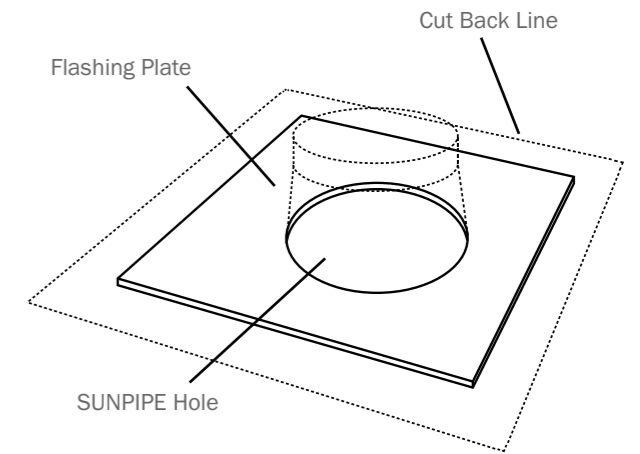

Ensure that the surface to receive the flashing plate is clean, dry and free from imperfections. If necessary, secure the flashing plate with 45 mm screws.

Using felt, asphalt or the membrane, appropriate to the roof covering you have, form a weatherproof dressing around the flashing plate, up to a height of 6" (150 mm).

Don't weatherproof on the upper vertical section of the flashing plate as it could obstruct the fitting of the ABS collar described later.

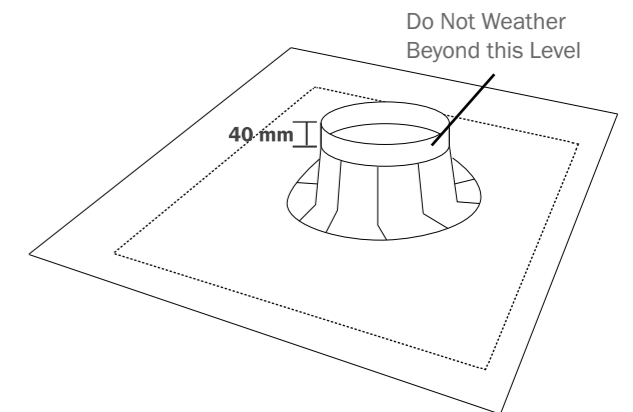

Once the flashing plate is secure and the weatherproof dressing finished, sit the ABS collar onto the flashing plate.

Fitting the Collar

Securely fix the ABS collar to the galvanised flashing plate using the self tapping stainless steel screws and neoprene washers provided.

Assembling the Pipe

Lie the pipe on its side with the seam facing upwards. It is important that the protective film should be left on the inside surface of the pipe until later.

Align the ends of the pipe. The special seams clip into one another forming a locking action. Put pressure on the seam all along its length to ensure the seal is secure.

Care must be taken when handling the SUNPIPE, as the edges may be sharp.

Run a Stanley knife down both sides of the joints at points 'A' as shown, where the protective film is attached to the inside of the pipe so as to be able to release the film later without too much difficulty.

Carefully apply a length of aluminium tape over the joint, as it is extremely difficult to remove the tape once applied.

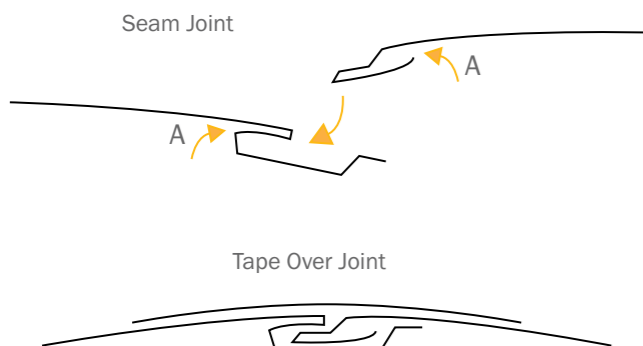

Assembling the Elbow Pipes (optional for 450 mm and 530 mm)

30° Elbow

1. Pop rivet section 1 together at 'c' and 'd'
2. Pop rivet section 2 at 'b'
3. Insert section 1 into section 2
4. Pop rivet section 2 at 'a'

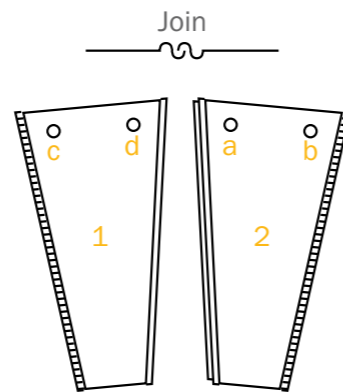

45° Elbow

1. Pop rivet section 1 together at 'a', 'b' and 'c'
2. Pop rivet section 2 at 'd'
3. Insert section 1 into section 2
4. Pop rivet section 2 at 'e'
5. Pop rivet section 3 at 'f'
6. Insert section 1 into section 3
7. Pop rivet section 3 at 'g'

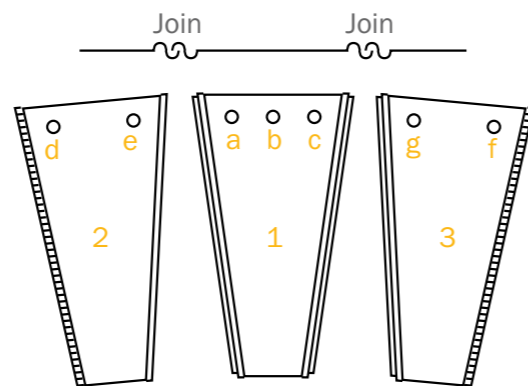

It is recommended that you peel back the protective lining just sufficient to assemble the elbow but leave the protective film in place to be removed after the fitting of the SUNPIPE.

Fitting the First Pipe

Carefully apply the brushed nylon gasket to the top of the collar (as shown). The gasket should be level with the top of the ABS flashing or collar. This gasket seals the SUNPIPE against ingress of dirt or insects but still allows the SUNPIPE to 'breathe', thereby preventing any later problems of condensation.

Measure the distance from the top of the collar to the underside of your ceiling. The pipe should project 5 mm above the collar and be cut approximately 50 mm above the room's ceiling.

If fitting additional lengths, please refer to FITTING ADDITIONAL EXTENSION PIPES AND BENDS on page 8.

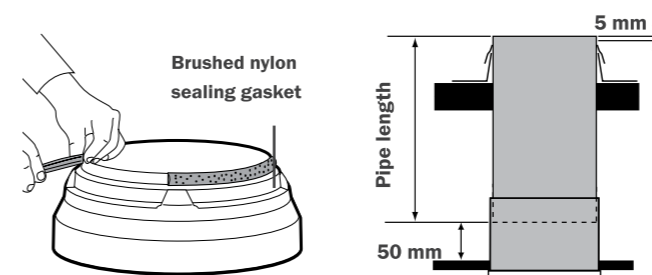

Insert the topmost pipe into the ABS flashing plate from underneath. Allow the pipe to project 5 mm through the top of the collar.

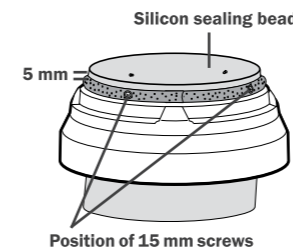

Secure the pipe in position using four of the 15 mm self tapping screws supplied, screwing through the brushed nylon gasket and into the rigid SUNPIPE.

Once the pipe is fixed in position, carefully wipe the top of the outer surface of the SUNPIPE to remove any moisture, dirt or finger marks, etc. and apply a thick bead of silicone sealant, to seal between the SUNPIPE and the ABS collar as shown, and then allow to dry.



This is the most important part of the SUNPIPE installation since this silicone sealant will prevent any rain or condensation from running down the outside of the SUNPIPE.

Fitting the Dome

Before attaching the top dome to the flashing or collar, peel the protective film from the top rim of the first pipe and push it down the pipe, just enough to form a protective 'plug' at the bottom of the pipe.

Take care not to scratch the dome when positioning it.



Align the pre-drilled holes on the dome with the lugs on the collar/upstand. Secure the roof dome to the collar/upstand using five 15 mm self tapping screws and washers supplied.

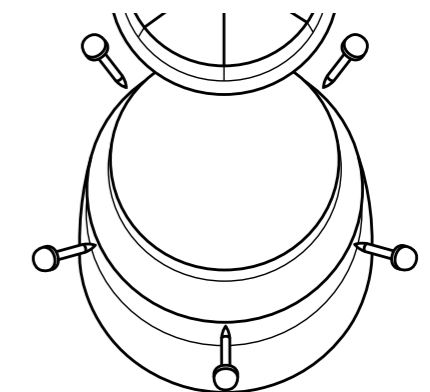

All external works are now complete.

Carefully brush down the roof covering and the flashing to remove any particles of dust or dirt. Clean the dome with a soft cloth and water to ensure that the dome is free from any finger marks, dust or dirt

Note: When the SUNPIPE is initially installed, particularly in winter months, the air contained within the SUNPIPE tube does contain moisture and it is quite common therefore to see beads of condensation forming on the inside of the SUNPIPE dome immediately after installation. This is quite normal and the design of the SUNPIPE dome is such that this condensation will run down the inside of the dome, into the condensation gasket and will dry out naturally.

Fitting Additional Extension Pipes and Bends

Fit additional straight lengths to suit your particular roof void. If there is a large roof void between your room and flat roof, you may need to connect additional pipes together. These additional pipes have crimped ends and therefore fit tightly into the plain ends of the pipe.

Alternatively you may want to create an offset. This is when the SUNPIPE has two elbow sections. This can enable the SUNPIPE to enter the room in a location which is not directly underneath where it exits through your roof.

Ensure all protective film is removed from the previous pipe before attaching the next section.

Ensure the final pipe has two plain ends as the slip length needs to fit over the bottom of the pipe.

When all connections are correct, drill small pilot holes on each side of the SUNPIPE tube to elbow joints and screw the joints together with self tapping screws.

The silver aluminium tape should be used to seal all the joints and seams against dust and dirt.

On long unsupported lengths of pipe, additional fixing screws can be used to fix the SUNPIPE to any adjacent joist or rafter. Perforated strapping and drop wires should be used where it is considered there is likely to be any weight imposed on the elbow joints, such as long horizontal runs or complicated routes where the SUNPIPE may have to twist and turn. Drop wires should always be fixed vertically and attached to the rafters above and the perforated strapping should be fastened around the SUNPIPE and secured with suitable fixings.

Fitting the Ceiling Diffuser

(For LuxLoop, refer to SUNPIPE LuxLoop Installation instructions)

To avoid any possibility of eye damage, be careful not to look upwards through the SUNPIPE.

Screw the fixing ring through ceiling and into the plywood backing template using five of the 32 mm screws supplied.



Remove the protective film from the assembled slip length. Pass this through the fixing ring and slide over the trimmed plain end pipe.



Remove any remainder of the protective lining

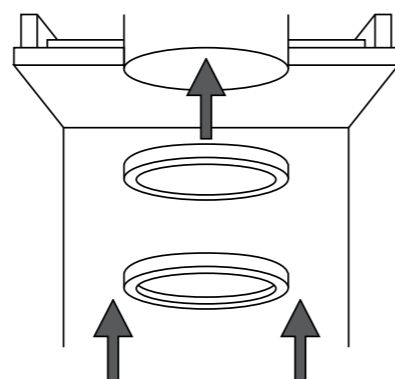

The ceiling diffuser is designed to push fit into the bottom of the slip length pipe.

Twist the turn buttons, which securely hold the diffuser in place. You can then clip the diffuser trim in place, making sure the lugs on the inside of the trim do not align with any of the screw position cut-outs on the fixing ring.

If the ceiling is not perfectly flat, such as an Artex ceiling or similar, apply a thin bead of a proprietary sealant, such as decorators mate, around the external edge of the white trim to seal any gap between the ceiling trim and the ceiling itself. Lugs must not align with the central ring diffuser clips. If it is ever necessary to remove the ceiling trim at a later date, clean off proprietary filler and remake the joint.

Seal all joints and seams of slip length with tape.

Dust may enter the SUNPIPE during installation, which may settle on the ceiling diffuser over a period of time. Simply remove the trim and diffuser and clean with a dry lint-free cloth, then replace and reseal if necessary.

No further cleaning or maintenance should be required but if flies or other insects appear in the diffuser, these should be removed. Some insects are attracted to strong light so carefully check to ensure that silver tape covers every possible gap or small hole.

Pitched Roof SUNPIPE

Components for a Standard Kit installation of a Pitched Roof SUNPIPE System

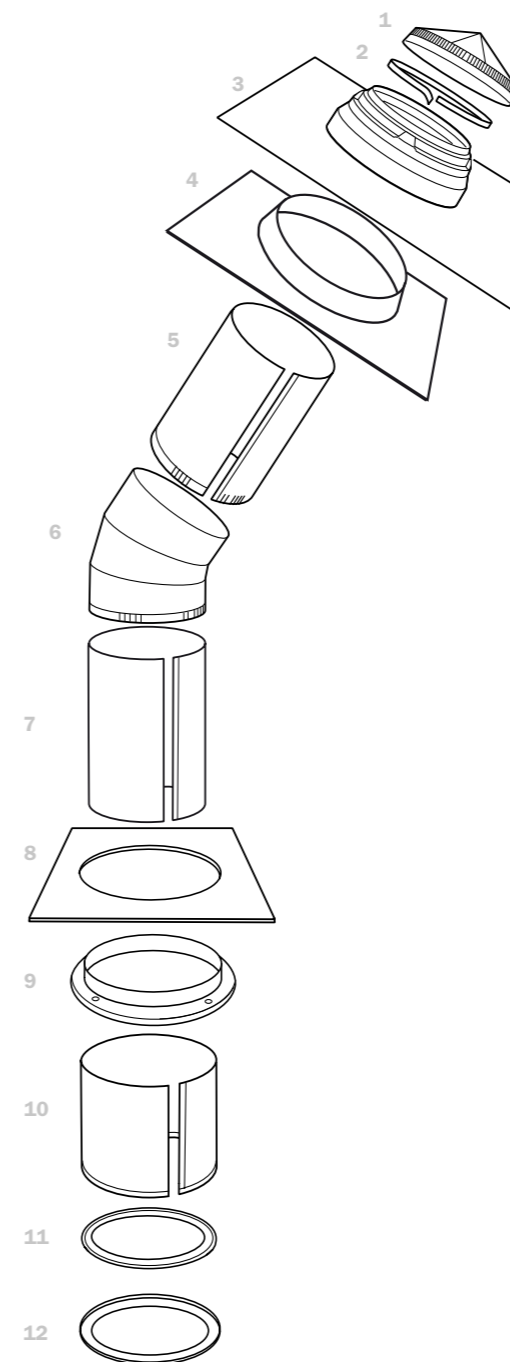

- 1. Diamond Dome**
High impact acrylic roof dome.
- 2. Brushed nylon condensation seal**
- 3. ABS flashing plate for slate pitched roof**
- 4. ABS undercloak roofing felt support**
- 5. SUNPIPE crimped end connecting piece**
Must be used at roof level (Cut to length on site)
- 6. 45° Adjustable Elbow**
- 7. Plain end SUNPIPE 610 mm**
Straight length of SUNPIPE SUPER- SILVER Aluminium Tubing. Must be used to terminate above ceiling level
- 8. 3 mm Plywood Backing Plate**
Template for marking ceiling opening and additional ceiling support
- 9. Fixing Ring**
Housing for diffuser components secured to the ceiling
- 10. SUNPIPE Slip Length**
Final length of SUNPIPE at ceiling level
- 11. Micro Prism Ceiling diffuser**
Double glazed ceiling diffuser designed for best dispersion of natural daylight
- 12. Clip on Diffuser Trim**
White ABS diffuser fascia

Optional Additional Components

- 610 mm Extension length with crimped end**
- 30° Adjustable Elbow**
Used where a small offset is required
- 45° Adjustable Elbow**
Used where a large offset is required

Alternative Components

- ABS flashing plate, weathering skirt and weathering foam for plain tiled roofs**
- Lead flashing for bold rolled tile roofs**
- ABS collar for use with lead flashing**

Installation Pack

- 6 x 35 mm or 45 mm Screws (depending on SUNPIPE size)
- 10 x Black Washers
- Silver Aluminium Tape
- Silicone Sealant

Before You Start

It's Safer to Fit the SUNPIPE Between Rafters

Most pitched roofs are constructed using the 'Cut Roof' or the 'Trussed Rafter' method. In newer buildings, trussed rafters are more common.

Cut Roof

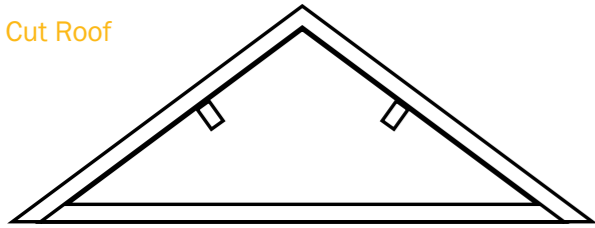

Trussed Rafter

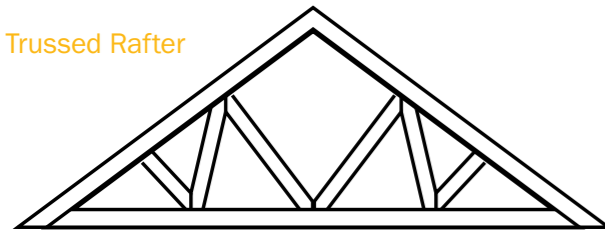

There are a variety of views that have been given in the past on the best position for a SUNPIPE on a north facing roof. Previously our advice was to fit a vertical flashing on a north facing roof. However, our experience indicates that on a north facing roof, whether the SUNPIPE is vertical or perpendicular to the roof surface, there is very little difference in performance and therefore we do not need to recommend the use of a vertical SUNPIPE. We recommend the compact flashing with an elbow used internally as for any other SUNPIPE application.

Different Roof Types

SUNPIPES are suitable for virtually any type of roof covering but these instructions are particularly written for slate or tiled roofs.

For bold roll tiled roofs, you will require our lead flashing.

For thatched roofs, metal profile, asbestos, or other unusual roof coverings, please call our technical department on 01494 897700.

External Preparation

You will need safe secure ladders and possibly a tower scaffold with all necessary safety rails to gain access to the roof surface. Ladders or tower scaffold must be safely tied into the building structure.

You will then need to gain access into the loft space, so from a secure and stable ladder or fitted loft ladder, enter the loft. The floor areas in some lofts are not safe to walk on.

Use temporary boards to span between the joists if this is the case. Look carefully at the area where you want to install your SUNPIPE. Make sure there are no obstructions to the installation such as water tanks, pipes, electrical cables, etc.

Positioning the SUNPIPE

Determine where you want the SUNPIPE to be positioned in the ceiling and where you want it to exit through the roof. For best results, try to position the dome directly above your chosen location of the ceiling diffuser not forgetting to allow for the elbow offset.

To aid the positioning you can place the plywood template at the chosen diffuser position and pre-assemble the first pipe, elbow and second pipe together.

Mark the diffuser position by drilling a small hole through the centre of the plywood template.

Push a screwdriver through the internal felt, and out through the external roof covering at the chosen location for dome. (This will lift the tiles and make it easier to see where you need to enlarge the hole for the SUNPIPE.

Remove sufficient tiles to mark and cut back the battens and cut diagonals in the felt covering to allow for the installation of the pipe. Refer to the table below to determine the size of the hole to mark.

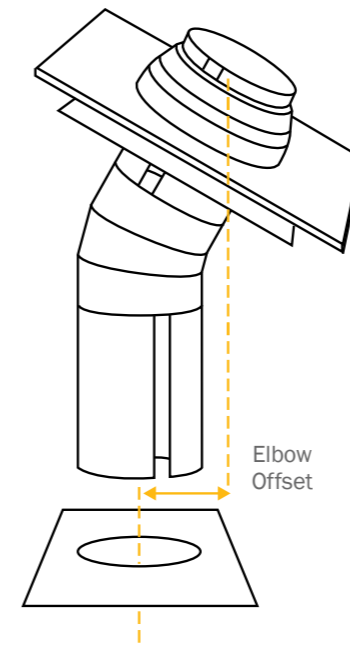

(Tip: you can also use the flashing plate to mark the hole size and position)

Nominal [mm]	SUNPIPE Diameter	Actual Diameter	Hole Size to Cut Ø
230	9"	230 mm	240 mm
300	12"	305 mm	315 mm
450	18"	458 mm	470 mm
530	21"	536 mm	550 mm

Removing the Tiles/Slates

Establish the position in which the SUNPIPE is to be installed by locating the screwdriver inserted from inside. Remove the tiles or slates from around the area and set aside.

Note: The plywood backing panel is not provided for 750 mm, 1000 mm and 1500 mm.

Nominal [mm]	SUNPIPE Diameter	Actual Diameter	Hole Size to Cut Ø
750	30"	762 mm	780 mm
1000	40"	1000 mm	1030 mm
1500	60"	1500 mm	1530 mm



Temporarily place the flashing plate in position so that it is centred over the pilot hole.



Insufficient Space Between Joists

If there isn't sufficient space, as a guide, on a 'cut roof', one rafter and ceiling joist may be cut to allow installation of your SUNPIPE. However, cross trimmers between adjacent rafters or ceiling joists must be installed at each side of the openings to support the 'cut' ends.

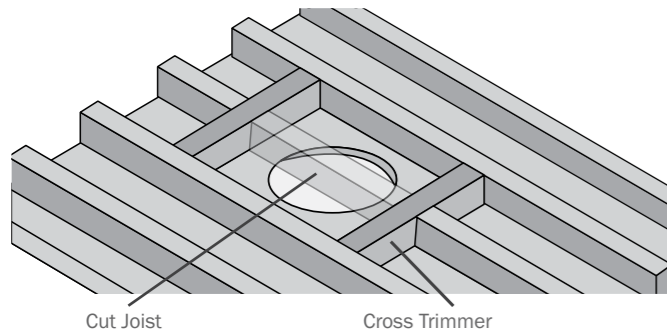

Under no circumstances should any element of a trussed rafter or, on a cut roof, a ridge timber, purlin or binder be cut without prior clearance from a structural engineer.

Best Location for a SUNPIPE

The most efficient place for your SUNPIPE is on a south facing roof slope. Always locate it as near to the ridge as possible.

Try to avoid sheltered or concealed areas of your roof since the SUNPIPE will not benefit from direct sunlight. In these circumstances the amount of light produced by the SUNPIPE which is in the shadow of the roof, will be similar to the amount of light obtained from a normally installed SUNPIPE on an overcast day.

Fitting the ABS Under-Cloak

The ABS under-cloak felt support plate is used to hold the roof felt in position to prevent it drooping. Once the position of the SUNPIPE has been determined and the felt cut, trim the ABS under-cloak with a Stanley knife to fit between the rafters then push up the under-cloak support plate towards the underside of the roof to make the roofing felt in a taut condition. Fix the support plate in position by screwing to the existing roof batons.

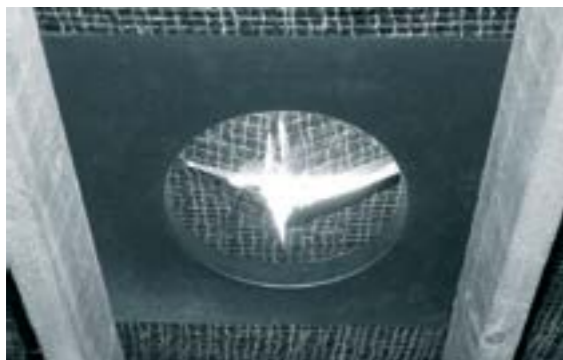

Alternatively, two additional noggins can be screw fixed into the rafters to support the ABS under-cloak plate

Installing the Flashing Plate on a Slate Roof

When fitting a SUNPIPE in a slate roof, the ABS flashing provides sufficient weatherproofing. Therefore the ABS flashing plate should be tucked under the row of slates above, interleaved with the slates on each side and sit on top of the row of slates below. Use the 45 mm long screws which are supplied, to fix the ABS flashing plate to the roof battens.

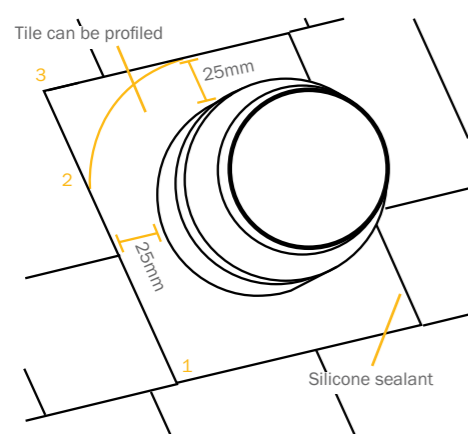

1. Wherever possible, align the bottom edge of the ABS flashing with the bottom edge of a row of slates. Cut the slate both sides and top to within 25 mm of the SUNPIPE flashing collar.
2. Then re-lay the next row of slates carrying the slate over the ABS flashing but stopping 25 mm short of the SUNPIPE upstand collar.

3. The third row of slates should then be carried over so as to weather the top edge of the ABS flashing.

Apply a thick bead of silicone sealant (supplied) around the slate edge and flashing plate to ensure a completely waterproof seal.

Installing the Flashing Plate on a Tiled Roof

When fitting the SUNPIPE in a plain tiled roof you should use the weathering skirt which is fixed using a Poly-Butyl strip and pop rivets.

Lay the skirt on a flat surface and clean off any dirt or dust. Take the ABS flashing and carefully remove the protective paper and then place it firmly on top of the skirt, allowing the skirt to overlap by approximately 50 mm to the underside of the ABS flashing. Secure the skirt with the pop rivets as shown.



Rivet positions

Carefully position the ABS flashing (with its skirt) onto the roof.

Fix down the ABS flashing plate to the roof battens using the 45 mm screws supplied as shown.

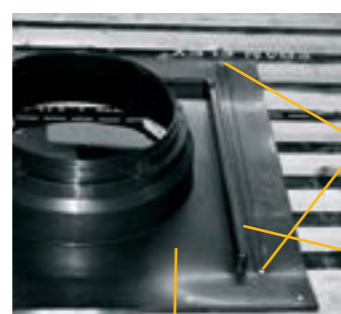

Weathering upstand

Make sure that you use two screws in line with the bottom edge of the ABS collar but also outside of the weathering upstand, this will pull the ABS flashing down on to the batten allowing the correct alignment of the roof tiles.

Apply a small amount of silicon sealant over the rivet and screw heads, this will ensure a waterproof seal.



Stick the foam weathering strip to the flashing as shown above, ensuring it's positioned outside the weathering upstand



You can then cut the tiles around the ABS upstand with an angle grinder and place the tiles in position to make sure they fit.



If necessary, grind off the corner nib on the back of the tiles to ensure the tiles sit correctly on top of the flashing plate.



Foam weathering strips stop water ingress.

Foam Weathering Installation (I)

Details for Plain Tiled Roofs

230 mm (9") and 300 mm (12") SUNPIPES - supplied with 2 x 750 mm strips of high density foam

Remove the covering of the fixing tape and bend the foam to the shape of the weathering upstand on the ABS flashing plate.

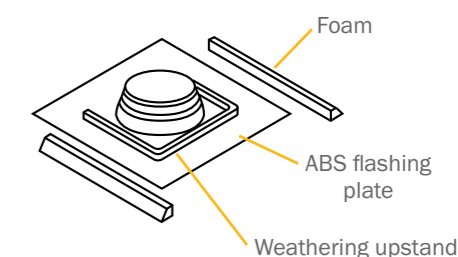

Adhere the foam to the flashing plate starting at the centre of the weathering upstand, with the angled edge of the foam facing outwards.

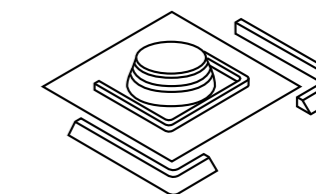

Repeat the process for the remaining piece of foam, so that the two pieces meet at the centre of the weathering upstand and trim foam to suit.

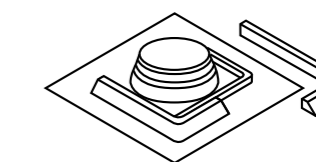

Repeat the process for the remaining piece of foam.

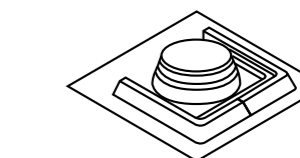

Foam Weathering Installation (II)

450 mm (18") and 530 mm (21") SUNPIPES

Supplied with 3 x 750 mm of high density foam.

Remove the covering of the fixing tape fit each length of foam to each section of the ABS flashing plate weathering upstand.

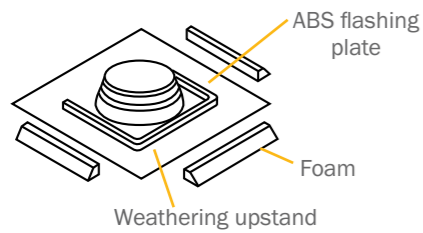

Trim to length as necessary.

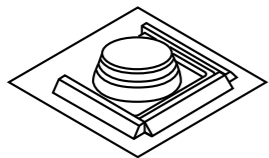

When the tile is placed on top, it will compress the foam but if necessary a mastic seal can be used.

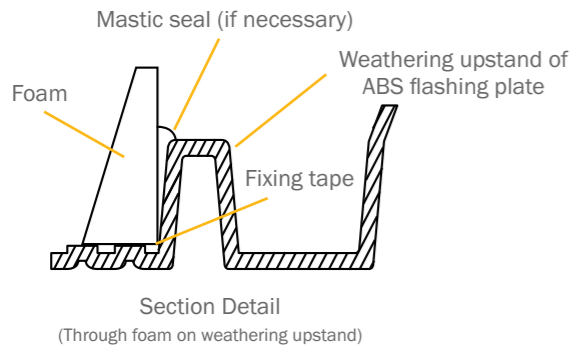

Note: Depending on tile type it may be necessary to trim the top foam and the foam strips either side of the flashing plate. When trimming the side strips they need to form a series of 'steps', as shown, where the tiles will sit.



This ensures the tiles will sit flat down on top of the flashing plate. Be careful not to cut too much as the foam needs to form a weatherproof seal between the flashing plate and tiles.

Fitting the Collar - Lead Flashings

Lead Flashings should **ONLY** be fitted by professional roofers and SUNPIPE installers.

Place the collar carefully over the top of the lead making sure to align one of the lugs on the collar pointing towards the ridge of the roof (as shown) then push down the collar so that it fits firmly on top of the lead.

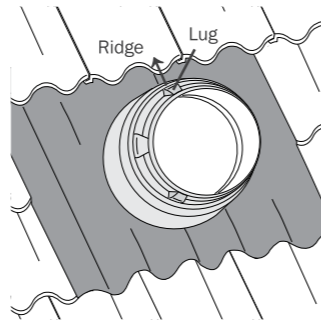

Drill five equispaced holes around the lowest part of the collar, then secure the collar to the lead flashing with closed pop-rivets (supplied). If you need to seal any of the lead, make sure you only use the lead sealant provided.



Assembling the Pipe

Please refer to **ASSEMBLING THE PIPE** and **ASSEMBLING THE ELBOW PIPES** on page 6.

Fitting the First Pipe

Ensure the first pipe is the SUNPIPE crimped end connecting piece

From the loft space push the first pipe (crimped end should be facing into the loft) through ABS undercloak and out through the flashing plate or collar by about 50 mm. Push in the elbow section, adjusting it by rotating the sections to achieve the correct angle so the crimped end of the elbow points vertically down.

Push the second pipe into the elbow opening and check it aligns to the ceiling opening position. If necessary, adjust the first pipe by sliding in or out of the flashing or collar to achieve this.

Once satisfied, remove the elbow and second pipe taking care not to move the first pipe, then return to the roof.

Trim the top of the pipe with tin snips (if necessary) to leave at least 5 mm of pipe protruding through the flashing or collar.

Carefully apply the brushed nylon gasket to the top of the collar (as shown). The gasket should be level with the top of the ABS flashing or collar. This gasket seals the SUNPIPE against ingress of dirt or insects but still allows the SUNPIPE to 'breathe', thereby preventing any later problems of condensation.

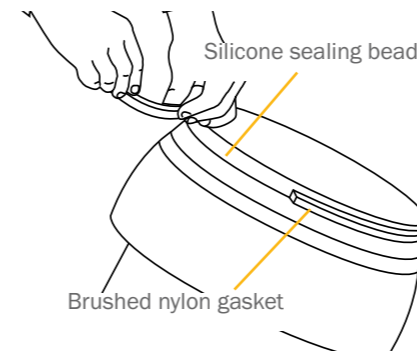

Secure the pipe in position using four of the 15 mm self tapping screws and washers supplied, screwing through the brushed nylon gasket and into the rigid SUNPIPE.

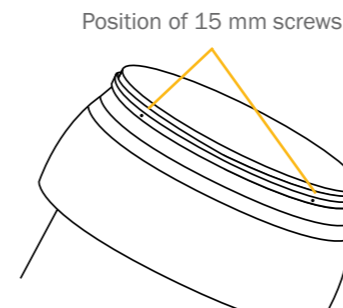

Once the pipe is fixed in position, carefully wipe the top of the outer surface of the SUNPIPE to remove any moisture, dirt or finger marks, etc. and apply a thick bead of silicone sealant, to the gap between the SUNPIPE and the ABS collar, and then allow to dry.

This is the most important part of the SUNPIPE installation since this silicone sealant will prevent any rain or condensation from running down the outside of the SUNPIPE which may create a water stain on the ceiling.

Fitting the Dome

Please refer to **FITTING THE DOME** on page 7.

Notes on Internal Arrangements for All Pitched Roof Installations

Peel off the coloured protective film down the first pipe, carefully allowing it to form a descending 'plug' which prevents dust or dirt getting into the pipe whilst the installation is being completed.

Push in the elbow, and check the alignment as described in FITTING THE FIRST PIPE on page 7 and adjust if necessary to achieve the correct angle so that crimped end of the elbow points vertically down.

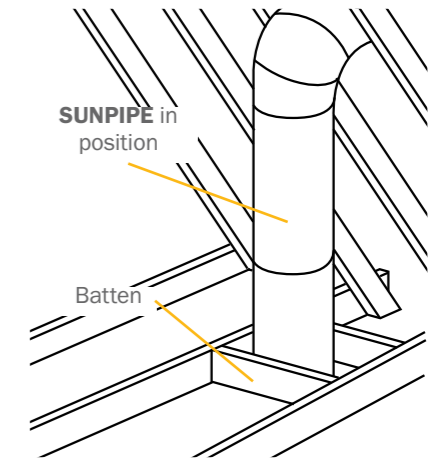

Ensure that all of the protective film is removed from the previous pipe or elbow just before attaching the next section.

The second straight section of pipe should then be assembled as previously described and the two (or more) pipes connected together. Once you are satisfied that the angle and the location of the tubes are correctly aligned to pass through the loft space, continue as above with third or fourth sections and further elbow joints, depending on the distance you are spanning.

Make sure the final pipe you use has two plain ends as the slip length needs to fit over the bottom of the plain end pipe.

When you are satisfied that the angles and connections are all correct, drill small pilot holes on each side of the SUNPIPE tube to elbow joints and screw the joints together with self tapping screws.

Use the silver aluminium tape to seal all the joints and seams against dust and dirt, apply carefully as it is extremely difficult to remove once applied.



On long unsupported lengths of pipe, additional fixing screws can be used to fix the SUNPIPE to any adjacent joist or rafter. Perforated strapping and drop wires should be used where it is considered there is likely to be any weight imposed on the elbow joints, such as long horizontal runs or complicated routes where the SUNPIPE may have to twist and turn. Drop wires should always be fixed vertically and attached to the rafters above and the perforated strapping should be fastened around the SUNPIPE and secured with suitable fixings.

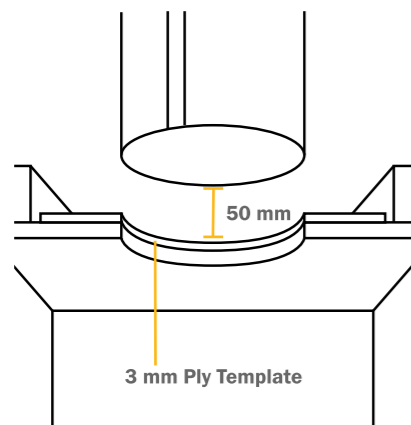

Having established the entry point of the SUNPIPE into the room below, use the 3 mm ply backing panel as a template to mark out the opening. Then use a pad saw or similar to carefully cut out the opening.

The bottom of the SUNPIPE tube should be trimmed back so that it is approximately 50 mm above the top of the ceiling.

Insert the 3 mm plywood backing panel in the ceiling space over the hole to provide extra support when fixing the ceiling diffuser (you may have to cut the plywood in two if you have limited access to the ceiling space)

Fitting the Ceiling Diffuser

Please refer to FITTING THE CEILING DIFFUSER on page 8.

Installation of Rooflight

To install the Square SUNPIPE roof-light follow the instructions provided on the packaging of the unit, once the unit is installed open the window and hold in position.

Take the aluminium SUNPIPE transition unit and carefully push through the opening.

The top edge of the transition unit should be level with the top of the internal timber frame, and should be fixed into position with the stainless steel screws provided.

Shut the roof-light and using the security screws and washers, screw through the front face of the frame lid into the unit behind to seal shut.

Continue with the remainder of the SUNPIPE system, as per the SUNPIPE Installation Instructions.

Fit the ceiling diffuser as shown on page 8.

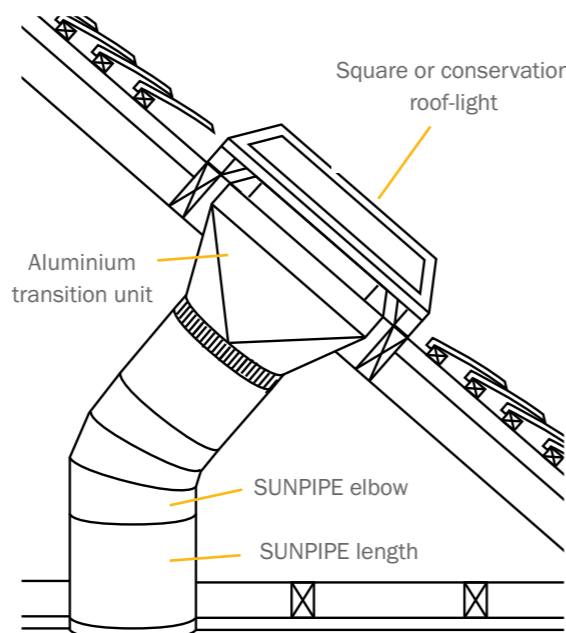

Should you have any queries, please telephone our Technical Department on 01494 897700.

Fireguard Ceiling Diffusers

There are two types of Fireguard ceiling diffusers, a ceramic Fireguard diffuser or a fire choke collar, but specialist fixing details are available separately in this respect on request.

Optional Accessories

Light Kit Fitting Instructions

Light Kit Components

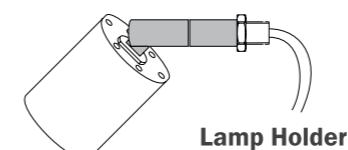

Lamp Holder



Halogen Lamp

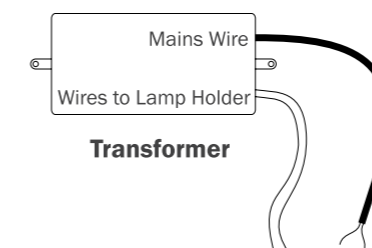

Transformer



Connecting Block

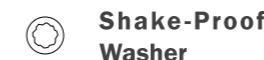

Shake-Proof Washer

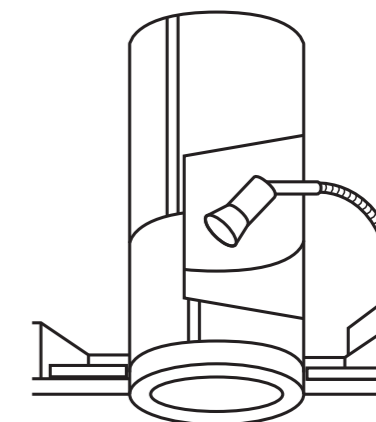

Pivot lamp holder through 45° and remove the locking nut.

From the inside of the SUNPIPE pass the wires and threaded end of the holder through the hole previously drilled in the SUNPIPE. Place the shake-proof washer over the threaded end of the lamp holder, thread the nut onto the lamp holder and finger tighten. Angle the lamp holder to point down towards the diffuser as shown and tighten locking nut. Push fit the lamp into the holder.

Wiring to the mains must be carried out by a qualified electrician

Using the connecting block connect the two wires from the lamp holder and the two wires from the transformer (not the mains brown and blue wires). The transformer can now be screwed to a rafter, if required.

Install the SUNPIPE as set out in these installation instructions, but do not fit the ceiling diffuser. If the ceiling diffuser is already fitted, gently prise off the diffuser trim, twist the little turn buttons on the fixing ring and remove the diffuser.

Mark the position of a hole to be drilled 300 mm (12") up from the base of the slip length on the outside of the SUNPIPE and drill a 10 mm diameter hole through the SUNPIPE.

Push the ceiling diffuser into the fixing ring. Twist the little turn buttons, which securely hold the diffuser in place. You can then clip the diffuser trim into place, making sure the lugs on the inside of the trim do not align with any of the screw position cut-outs on the fixing ring.

Motorised Light Shut-Off Damper

We produce a motorised light shut-off damper but this is normally used for commercial applications.

Installation is relatively simple, following the same sequence as installing generally, but due consideration should be given to the weight of the motorised shut-off damper and providing a suitable support method, to ensure that the unit is properly supported from the roof structure and does not rest on the ceiling.

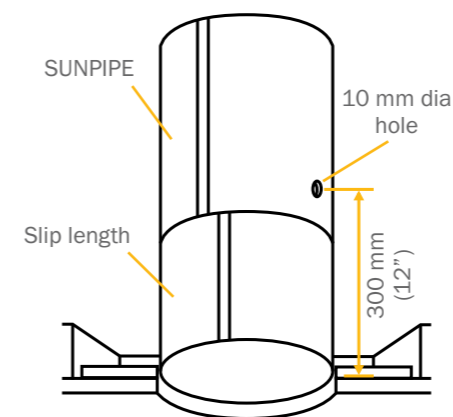

Remove any burrs from the inside and outside of the SUNPIPE taking care not to scratch the inside of the SUNPIPE.

Wiring to the mains must be carried out by a qualified electrician

SUNCATCHER & Additional Features

There are two types of SUNCATCHER, the ABS 350 and ABS 550 system.

Flat Roof

As detailed in Fig A, follow the procedure as set out in FLAT ROOF SUNPIPE on page 3 of this installation booklet.

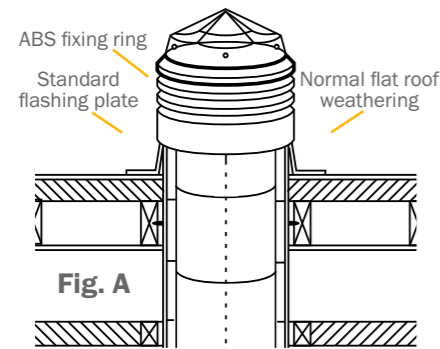

An opening needs to be formed through the flat roof of either 320 mm dia (for the ABS 350) or 520 mm dia (for the ABS 550).

Both systems are designed to be installed without the necessity of cutting any structural timbers but as set out in INSUFFICIENT SPACE BETWEEN JOISTS on page 4, it may be necessary to trim just one flat roof joist.

Install the ABS or galvanised standard flat roof flashing plate according to the roof type and once correctly positioned, weather in the flashing plate, as set out in EXTERIOR PREPARATION on page 4 of these instructions.

A separate ABS fixing ring is supplied and should be secured in position by pop rivets or screws to the top of the flashing plate.

Thereafter, the ABS unit should be lowered into position and slide over the ABS fixing ring, so that the fixing ring is flush with the underside of the outer skirt. Ensure this is level and then fix the outer skirt to the ABS fixing ring using screws or pop rivets.

Pitched Roof

All ABS SUNCATCHER systems must be installed vertically as shown.

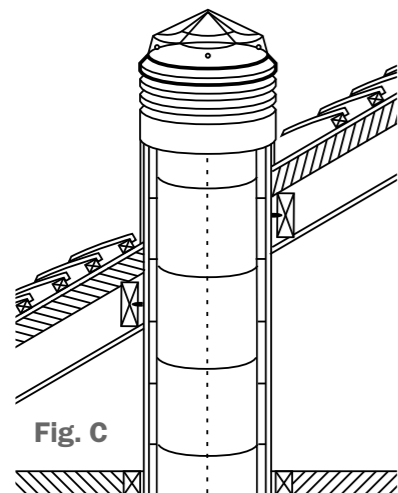

For Bold Roll roofs a pre-formed lead flashing is utilised. At the rear and sides of the flashing it may be necessary to dress the lead to the roof profile. An extended ABS skirt is provided.

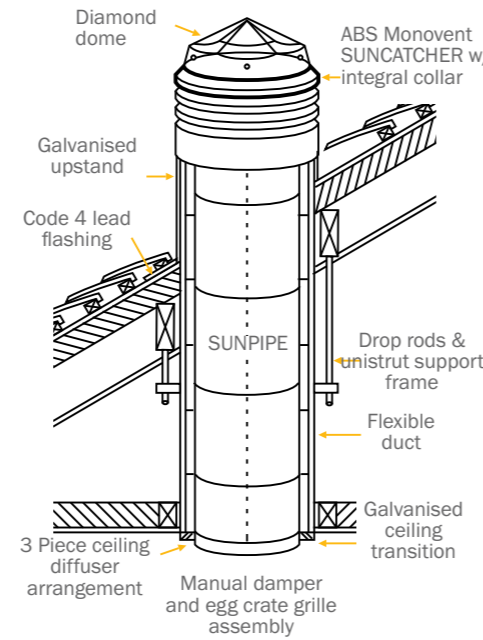

Internal Fixing Arrangement

A galvanised builders band (not supplied) should be fitted to the lower section of the trunk and attached firmly to the joists bridging any gaps, as shown below.



Assembling the SUNPIPE and Top Dome

Install the SUNPIPE components following the procedure as in ASSEMBLING THE PIPE to FITTING ADDITIONAL EXTENSION PIPES on pages 6 to 8. Please note the nylon sealing gasket is pre-assembled to the SUNCATCHER system.

Make up the remaining SUNPIPE components. Establish the ceiling opening location but do not secure into position at this stage.

Make up the remaining SUNPIPE components ensuring that the SUNPIPE terminates 5 mm above the internal ABS body and seal the joint with the silicone sealant provided. Establish the ceiling opening location but do not secure into position the SUNPIPE components at this stage.

Installing the Galvanised Ceiling Transition

Mark the required position of the ceiling opening from above using the Galvanised Transition as a template. Drill and provide a pilot hole to the centre of the opening.



Additional trimmers maybe required to secure the Galvanised Transition in place. Cut the ceiling opening using a pad saw.



Push the Galvanised Transition through the ceiling opening until it is approximately 5 mm below ceiling level. Fix the Galvanised Transition in place using the screws supplied fixing into the side trimmers.



Installing the SUNPIPE Components and Flexible Ventilation Ducting

Measure the required flexible ducting length and cut to length using scissors and wire cutters. Secure the top section of flexible duct to the galvanised body using the clamp band supplied. Tie up the end of the flexible ducting to allow the fitting of the remaining SUNPIPE components.

Install the SUNPIPE components (excluding the Slip Length) down to ceiling level and secure into position as shown in ASSEMBLING THE PIPE to FITTING ADDITIONAL EXTENSION PIPES on pages 6 to 8.



Once all the SUNPIPE components (excluding the Slip Length) are fitted, secure the bottom section of flexible ducting to the ceiling unit using the clamp band supplied.

Pull the flexible ducting tight to ensure the smooth passage of air.

Installing the Prismatic Diffuser and Ceiling Bezel

Pass the Slip Length through SUNCATCHER ceiling bezel and push the slip length into the inside of the SUNPIPE, all as set out in FITTING ADDITIONAL EXTENSION PIPES on page 8 of these instructions. Ensure that the diffuser terminates approximately 15 mm below ceiling level and then tape the Slip Length into position, inside the SUNPIPE on a temporary basis.



Align the clear polycarbonate air vent diffuser into position and drill through the fixing lugs into the ceiling and fix into position using the screws supplied. Be careful not to over-tighten the diffuser to the plasterboard ceiling, as this may prevent the white diffuser bezel clipping on to the air vent diffuser.



Finally clip the white diffuser bezel into place making sure to align the lug with the cut-out on the diffuser.



Suspended Ceilings

For installations into a suspended ceiling, a 12 mm plywood template will be required. Cut the plywood to the same size as the ceiling tile. Mark the position of the opening centrally to the ceiling tile and fix battens to the plywood template to secure the galvanised transition. Finally glue/contact adhesive the ceiling tile to the plywood template and the cut hole of both the plywood and the ceiling tile. Thereafter proceed as the step before.

Commercial SUNPIPES

Monodraught manufacture a number of commercial SUNPIPES, particularly the 750 mm and 1000 mm Diamond Dome system and 1500 mm diameter Hemispherical Domes, these are normally installed to a flat roof or metal standing seam roof.

The installation procedure will be basically the same as the Installation Instructions on the smaller systems.



The 750 mm Diamond Dome



Installation method to a standing seam metal profile roof (for all sizes)

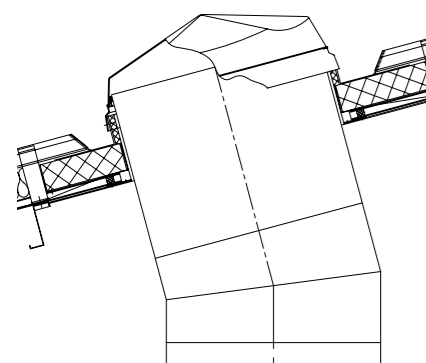

Installation drawings are normally provided for such commercial applications by Monodraught.

A limited range of accessories are also available.

Protective Film

Protective Covering Technical Information Sheet

A protective covering is applied to the surface of the aluminium SUNPIPE lengths to protect the super-silver mirrored surface during the manufacturing process, during storage and in transport. This covering is susceptible to various environmental conditions and the appropriate care must be taken to ensure the SUNPIPE components remain free from residue and to maintain the integrity of the reflective surface.

During storage, the following guidelines must be adhered to, and the material should be:

- Protected against the effects of strong light (e.g. Sunlight, Electrical Lighting)
- Protected against excessive heat (e.g. Radiators, Electric Heaters)
- Stored in temperatures below 40 °C
- Stored in low to medium humidity
- Protected from all moisture and water (e.g. Rain)

Avoiding large fluctuations in temperature and humidity is important during the storage of SUNPIPE components especially if items are being stacked together in bulk quantities.

The above guidelines should be adhered to so as to ensure that the pipe components do not "sweat" which can lead to the protective film becoming stuck to the surface, corrosion, or staining of the finished pipes.

Removal of the protective film

The protective tape is to be removed as soon as the product has been assembled and should not be left on such that excessive exposure to UV, moisture, or heat can occur, which in turn could damage the product.

Information

Frequently Asked Questions

How long can a SUNPIPE be?

A SUNPIPE can be almost any length that you wish, but loses 6% of light for every metre of SUNPIPE. For very long SUNPIPES, a larger diameter should be used. There is a 12% light reduction for every 45° bend. On smaller sizes the total effective maximum length is 8 m, and up to 20 m on larger sizes.

What spacing should I use for SUNPIPES?

In general terms we recommend 230 mm diameter SUNPIPES at 2 m, 300 mm diameter at 3 m intervals, 450 mm diameter SUNPIPES at 4 m intervals and 530 mm diameter SUNPIPES at 5 m spacings.

Do I need planning permission?

No, normally it is not necessary to apply for planning permission for the installation of a SUNPIPE. However, if your property is situated in Scotland or a Conservation Area then specific permission must be obtained from your Listed Building Officer.

Are SUNPIPES suitable for use in a bedroom?

Yes, but bear in mind that in summer months, due to the efficiency of the SUNPIPE, your bedroom will be flooded with natural day light first thing in the morning. For this reason, installations in bedrooms or hospital wards can have a motorised light shut off damper.

Does the SUNPIPE require maintenance?

Due to the shape of the dome, the SUNPIPE is self-cleaning. The ceiling diffuser fits snugly into the base of the fixing ring to prevent dust or dirt entering the system and as a result the interior mirror finish surface never requires any maintenance. If however you are fitting a light kit, the bottom ceiling diffuser can be removed but care must be taken not to leave fingermarks on the internal mirror finish of the SUNPIPE.

Will the top dome discolour over time?

No, because our domes are manufactured from acrylic, therefore there is no discolouration to our domes over the life of your SUNPIPE system. This has been tested and verified by the Building Research Establishment (BRE). Full test reports available at www.monodraught.com.

How much light output will I achieve?

The light output will vary accordingly to the time of the year, the position of the SUNPIPE on your roof, the size of SUNPIPE and the internal finishes of your room.



Halifax House, High Wycombe
Buckinghamshire, HP12 3SE



+44 01494 897700



+44 01494 532465



www.monodraught.com



info@monodraught.com



Monodraught Ltd



@MonodraughtLtd @cool_phase



Monodraught Ltd



Monodraught[®]

engineering delivered. naturally