

HRV1 *Q Plus*
TP410B

HRV1.25 *Q Plus*
TP416B

HRV1.75 *Q Plus*
TP414B

HRV2 *Q Plus*
TP411B

HRV2.85 *Q Plus*
TP417B

HRV3 *Q Plus*
TP412B

Product Manual

Heat Recovery Ventilation Units



Contents

Warnings, Safety Information and Guidance

Important Information	3
Titon Recommend:	4

Product Overview

Product Description	5
Packaging Contents	5
Dimensions	6

Installation

HRV 1,1.25,1.75, 2, 2.85 & 3 Q Plus	7
Condensate Drain	8
Ducting Connections	9
Wiring Connections Access	9
Wiring Diagrams	11
Wiring Diagrams	12
Wiring Diagrams	13
Duct Heater	14
Fitting	14
Connection to Mains	15
Maintenance	15
Overheating	15
Commissioning	16

Maintenance

Routine Maintenance	17
Front Cover Removal	17
Cleaning Exterior	17
Condensate Tray	17
Filter Replacement	18
How to Change Filters	18
Service Record	19



When this document is viewed as a PDF the headings & sub headings on this page are hyperlinks to the content. Additionally the page numbers in this document are hyperlinks back to this contents page.

Warnings, Safety Information and Guidance

Important Information

Important: read these instructions fully before the installation of this appliance

1. Installation of the appliance and accessories must be carried out by a qualified and suitable competent person and be carried out in clean, dry conditions where dust and humidity are at minimal levels.
2. This manual covers the installation of the HRV, see aurastat® HRV Controller Product Manual for commissioning and operation.
3. All wiring must conform to current I.E.E. Wiring Regulations and all applicable standards and Building Regulations.
4. Inspect the appliance and electrical supply cord. If the supply cord is damaged, it must be replaced by the manufacturer, their service agent or similarly qualified persons in order to avoid a hazard.
5. The unit is supplied with a mains rated 3 core flexible cord (PVC sheathed, brown, blue and green/yellow 0.75mm²).
6. The appliance must be connected to a local double pole isolation switch with a contact separation of at least 3mm.
7. The appliance must be earthed.
8. HRV1, 1.25, 1.75, 2 & 2.85 Q Plus are suitable for 230V ~ 50/60Hz single phase with a fuse rating of 3A.
9. HRV3 Q Plus suitable for 230V ~ 50/60Hz single phase with a fuse rating of 5A.
10. aurastat®, control & communication cable access is via the fitted cable gland(s) which are suitable for Ø3- 6mm cable.
11. aurastat® control & communication cable - Unshielded 4 Core 18-24AWG Stranded, Tinned Copper.
12. Control & communication cables should not be placed within 50mm or on the same metal cable tray as any 230V lighting or power cables.
13. Ensure all cable glands are fully tightened.
14. The unit must be stored in a clean and dry environment. Do not install the appliance in areas where the following may be present or occur;
 - Excessive oil or a grease laden atmosphere,
 - Corrosive or flammable gases, liquids or vapours,
 - Ambient temperatures above 40°C or below -5°C,
 - Humidity levels above 90% or is a wet environment.
15. The appliance is not suitable for installation to the exterior of the dwelling.
16. This appliance can be used by children aged from 8 years and above and persons with reduced physical, sensory or mental capabilities or lack of experience and knowledge if they have been given supervision or instruction concerning use of the appliance in a safe way and understand the hazards involved.
17. Children should be supervised to ensure that they do not play with the appliance.
18. Ensure that external grilles are located away from any flue outlet, in accordance with relevant Building Regulations.
19. The unit must not be connected to a tumble dryer.
20. The unit must not be connected to a cooker hood.
21. Precautions must be taken to avoid the back-flow of gases into the room from an open flue appliance.
22. Ensure all ducting, condensate drain and associated pipe work is free from debris and blockages before switching on the unit

Titon Recommend:

1. Ø125mm ducting is used to connect the HRV1 & 1.25 *Q Plus*.
2. Ø150mm ducting is used to connect the HRV1.75, 2, 2.85 & 3 *Q Plus*.
3. A short piece of flexible ducting, approximately 200mm long is used to connect the unit to the ducting system.
4. Any flexible ducting used must be pulled taught.
5. A minimum distance of 200mm between the HRV unit and any sharp bends in duct work. Ducting should be insulated where it passes through unheated areas and voids with the equivalent of at least 25 mm of a material having a thermal conductivity of $\leq 0.04 \text{ W/(m.K)}$ to reduce the possibility of condensation forming. Where a duct extends externally above roof level the section above the roof should be insulated or a condensate trap should be fitted just below roof level.
6. Ducts within the building heated envelope between the external terminals and the unit's From Atmosphere and To Atmosphere ports should be insulated and wrapped additionally with a vapour barrier outside the insulation.
7. Where ducts pass through fire barriers, they must be appropriately fire stopped in accordance with the requirements of Part B of the Building Regulations (for England & Wales).
8. A ducting condensate drain must be fitted to vertical To Atmosphere duct work.
9. Ducting must be installed in such a way that resistance to airflow is minimised.
10. Ducting connected to the From Atmosphere & To Atmosphere ports, must be to/from the external air outside the building envelope.
11. Duct joints to the unit's duct ports must be fixed using a method that ensures a long term seal is achieved. If using a short piece of flexible ducting secure using a hose clamp, do not over tighten.
12. A minimum distance of 2m exists between the external supply and exhaust terminals .

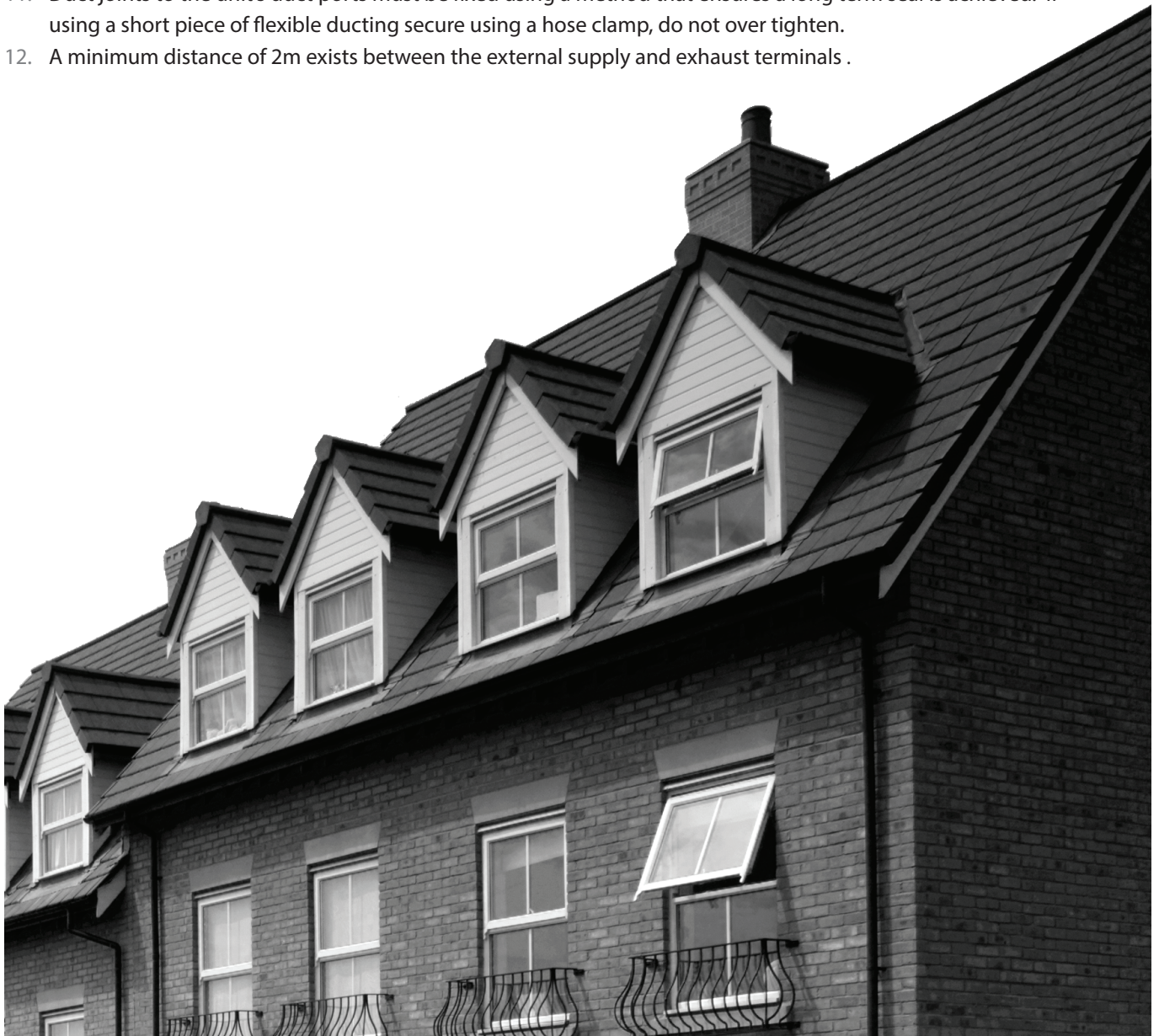

Product Description

The HRVs are Mechanical Ventilation with Heat Recovery (MVHR) units. They are designed for the energy efficient ventilation of dwellings. The units are designed for continuous ventilation, exhausting stale moist air from bathrooms, toilets, kitchen and utility rooms. As the stale air is extracted, the unit's heat exchanger transfers heat, which would have been wasted, to the fresh air being supplied to the bedrooms and living rooms.

The units in this product manual are designed to work with the Titon aurastat®.

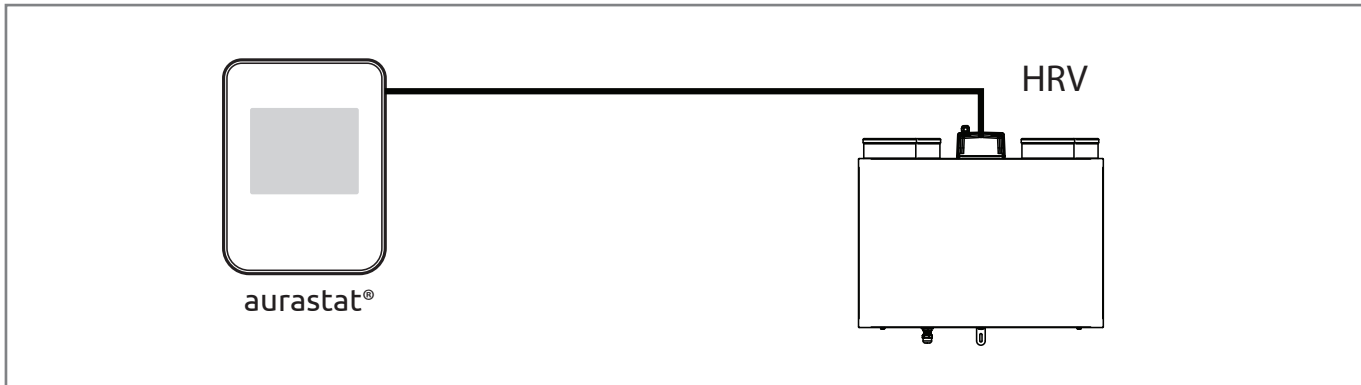

Packaging Contents

Inspect the unit when taking delivery. Check the unit for damage and that all accessories have been supplied. Package supplied with;

- HRV unit x 1
- Mounting Bracket x 2
- Safety Bracket x 1
- 15mm Condensate Drain Olive & Nut x 1
- M6x10mm Pan head screws x 4
- M6 washers x 4
- Transport Bungs x 4, supplied packed in Duct Ports
- Product Manual x 1
- User Guide x 1

Any shortages or damage must be immediately reported to the supplier.

Dimensions

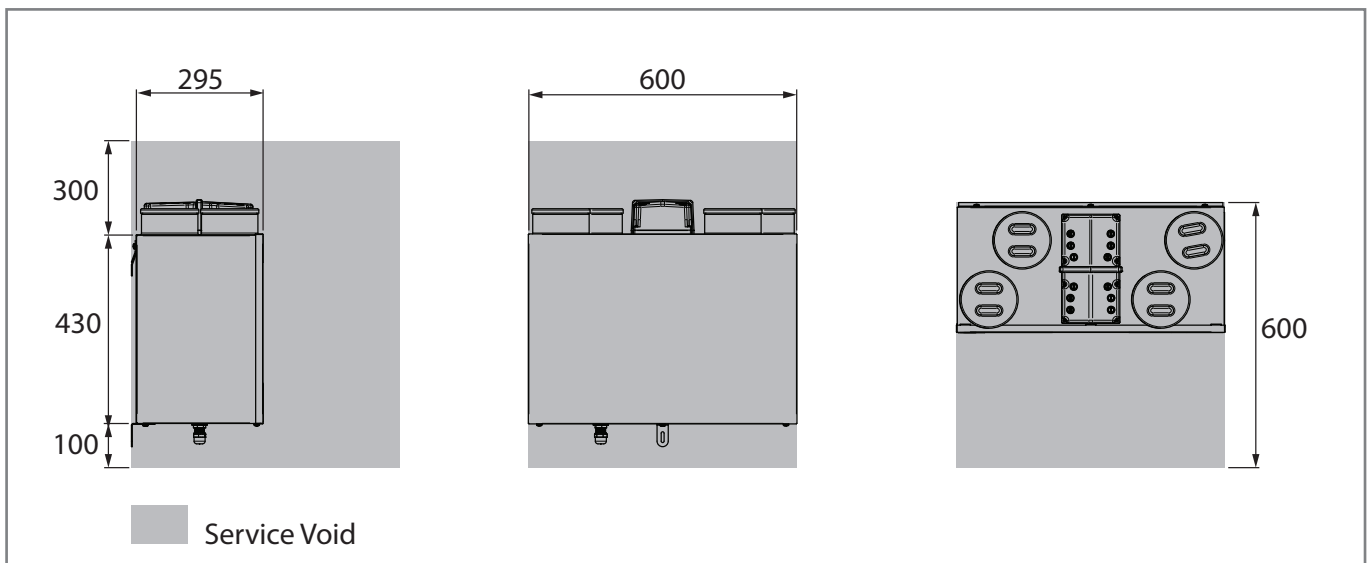

HRV 1 & 1.25 Q Plus DO NOT BOX IN UNIT

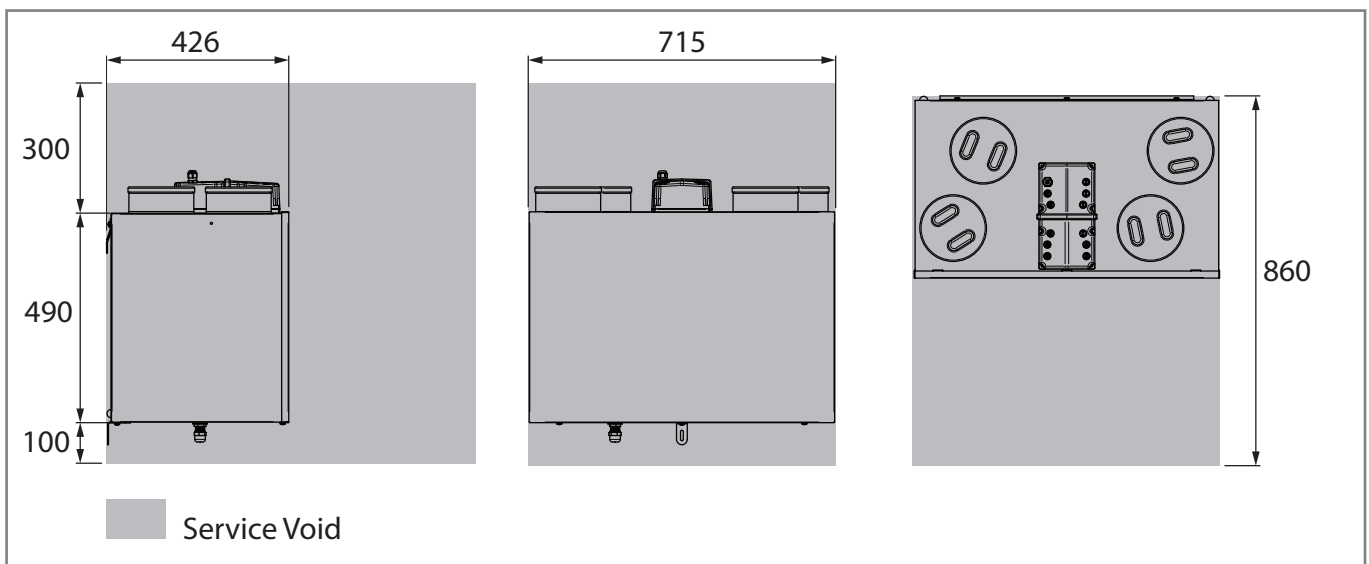

HRV 1.75, 2, 2.85 & 3 Q Plus DO NOT BOX IN UNIT

HRV 1,1.25,1.75, 2, 2.85 & 3 Q Plus

Read and observe the guidance & safety notices listed in Warnings, Safety Information and Guidance on page 3.

Titon recommend the use of guidance given in the Domestic Ventilation Compliance Guide 2010 Edition ISBN-978 1 85946 378 9 and Approved Document Part F 2010 ISBN-978 1 85946 370 3 for all installations in the United Kingdom.



The above documents can be downloaded free from www.planningportal.gov.uk.

Do not remove the Port Covers until connecting ducting. Port Covers are fitted to prevent debris falling into the unit and causing blockages and damage:

- The Titon HRV *Q Plus* is designed to be mounted on a wall or similar. The mounting surface must be sufficiently strong to support the unit.
- Consider the positioning of electrical services and the Condensate Drain when siting the unit.
- Ensure there is sufficient access around the HRV *Q Plus* for future maintenance.
- Do not 'box-in' the unit making access to the unit difficult for maintenance and repair.

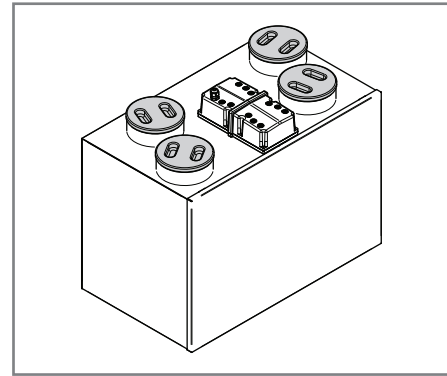

The Unit Must be mounted plumb and level front to back and side to side.

1. Mark a horizontal line on the wall using a spirit level. This line will be approximately 95mm below the location of the top face of the unit when fitted (excluding duct ports)
2. Use one of the Mounting Brackets as a template to mark the three fixing hole centres
3. Drill holes for fixings, always use a fixing suited to the wall type
4. Fix one Mounting Bracket to the wall ensuring the interlocking side is at the top, as shown
5. Fix the remaining Mounting Bracket to the unit using the M6 screws and washers provided, ensuring the interlock side is at the bottom. Do not overtighten
6. Mount the unit by locating the two Mounting Brackets together. Ensure a positive location is made between the two Mounting Bracket
7. The Safety Bracket MUST be fitted. Fix the lower Safety Bracket as shown using the remaining M6 screw, washer and suitable wall fixing. Packing to be used as required behind the Safety Bracket to ensure unit is level

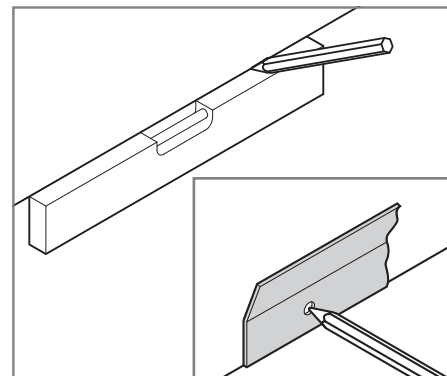
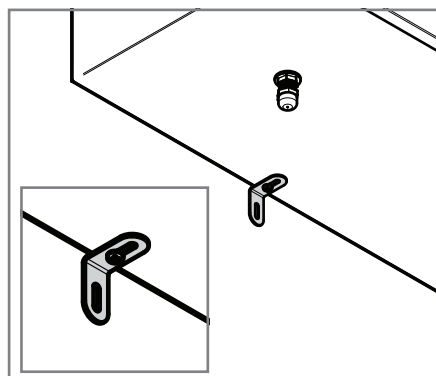
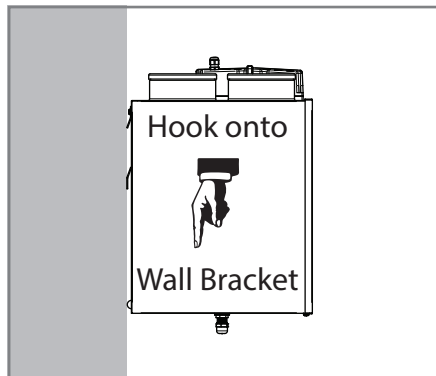

Mounting Bracket highlighted

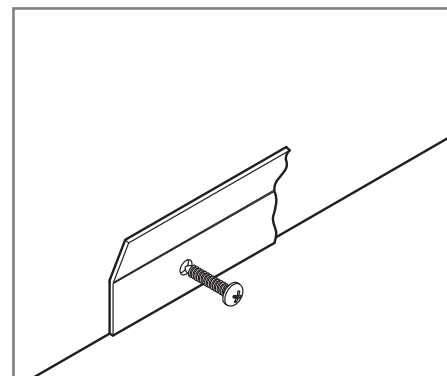

Safety Bracket highlighted

Condensate Drain

The unit's Condensation Drain Pipe must be fitted and connected to the dwelling's foul water drainage system in accordance with the relevant building regulations.

The Condensation Drain Pipe:

- Is attach via a 15mm compression fitting (drain pipe shown un-insulated for clarity), on the base of the unit
- Must incorporate a suitable trap, which must act as an air lock
- Must be adequate secured and be insulated with the equivalent of at least 25mm of insulating material with a thermal conductivity of 0.04 W/(mK) if any part of the pipe passes through an unheated void
- Should be installed to have a minimum 5° fall from the unit
- Titon recommend the use of diaphragm type waste valve in place of a conventional 'wet' trap which could dry out. Such as, BRE certificate no. 042/97 'Hepworth Hepv0 Hygienic self sealing plastic waste valve' recommended as an alternative to traditional U-Traps

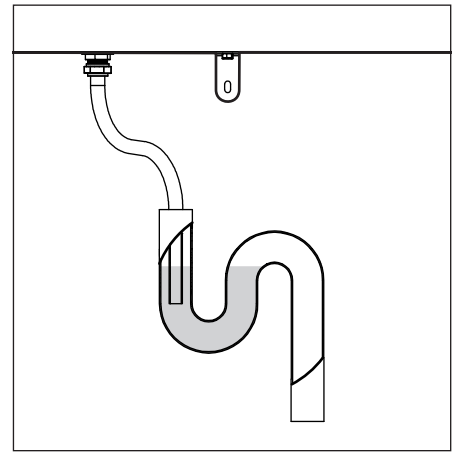
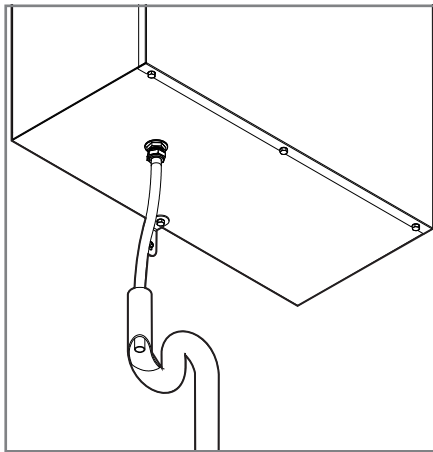

Ducting Connections

Read and observe the Warnings, Safety Information and Guidance.

Titon recommend the use of guidance given in the Domestic Ventilation Compliance Guide 2010 Edition ISBN-978 1 85946 378 9 and Approved Document Part F 2010 ISBN-978 1 85946 370 3 for all installations in the United Kingdom.



The above documents can be downloaded free from www.planningportal.gov.uk.

Once the unit has been installed and the ducting is ready to connect to the unit, remove the Port Covers from the Duct Ports.

The HRV unit has a label on the top with the icons indicating which port is which.

It is very important that ducting is connected to the correct ports in line with the icons below.



EXTRACT FROM DWELLING - This duct port is connected to the ducting that carries waste air from the 'Wet Rooms' to the HRV unit.



TO ATMOSPHERE - This duct port is connected to the ducting that carries the waste air to outdoors from the HRV unit.



SUPPLY TO DWELLING - This duct port is connected to the ducting that carries the fresh warmed air to the habitable rooms from the HRV unit.



FROM ATMOSPHERE - This duct port is connected to the ducting that carries fresh outdoor air to the HRV unit.

Wiring Connections Access

All wiring must conform to current I.E.E. Wiring Regulations and all applicable national standards and Building Regulations. Read and observe the Warnings, Safety Information and Guidance.

The electronics compartment is mounted on top of the unit. The compartment has two removable lids, front & rear. The front lid must always be removed before the rear lid; both lids are fixed by four screws. All wiring must be routed into the electronics compartment via the knock-outs and using cable glands or similar.

Wiring Diagrams

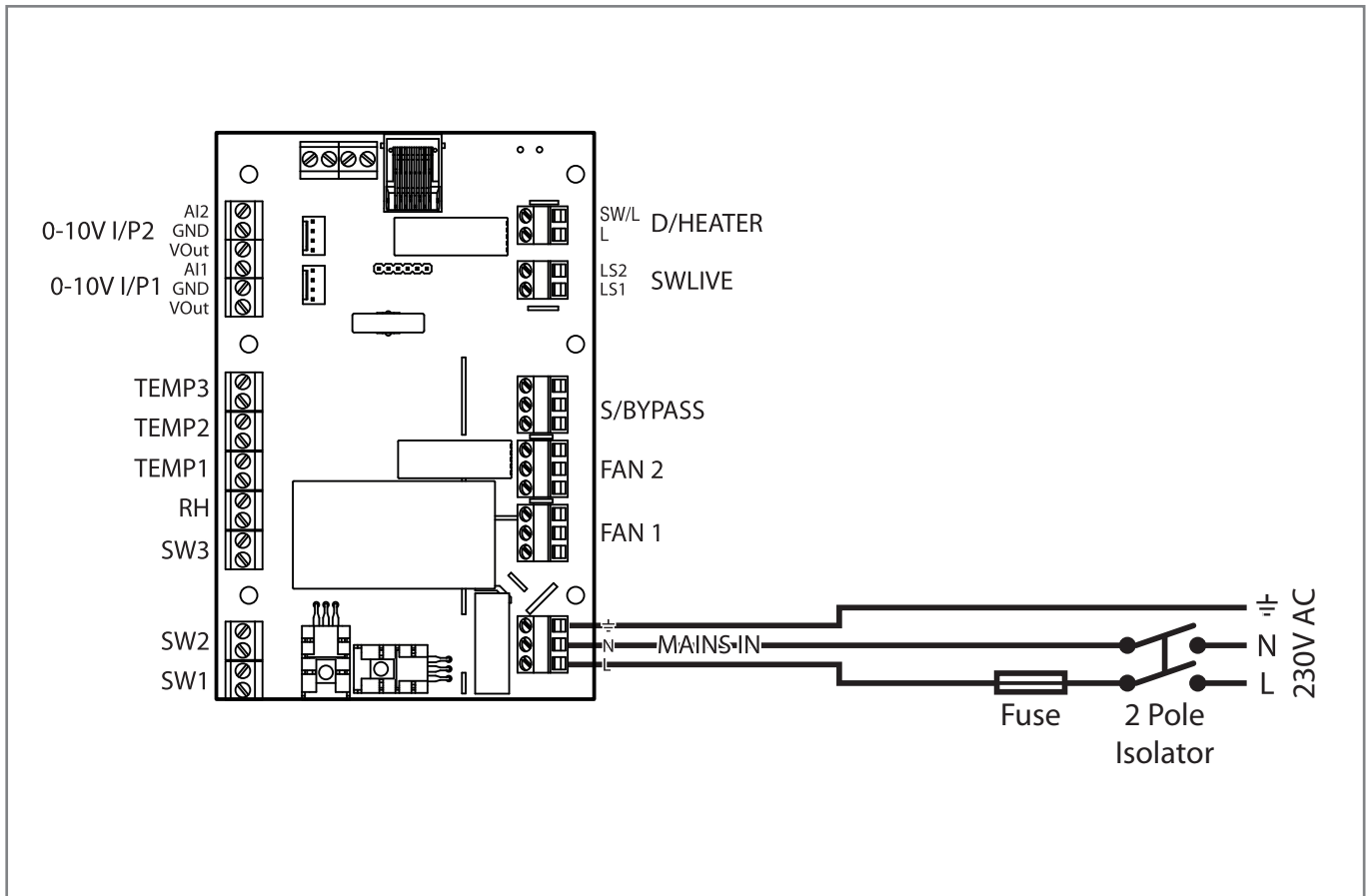

Supply wiring Ref EE167

The Switched Live (LS1, LS2) Boost(s) must be supplied via the same circuit as used to power the unit.
 A 3 (LS1 only) or 4 (LS1 & LS2) pole local isolator must be installed. The Boxed Relay (Part No. TP505) may be required to switch from other circuits.

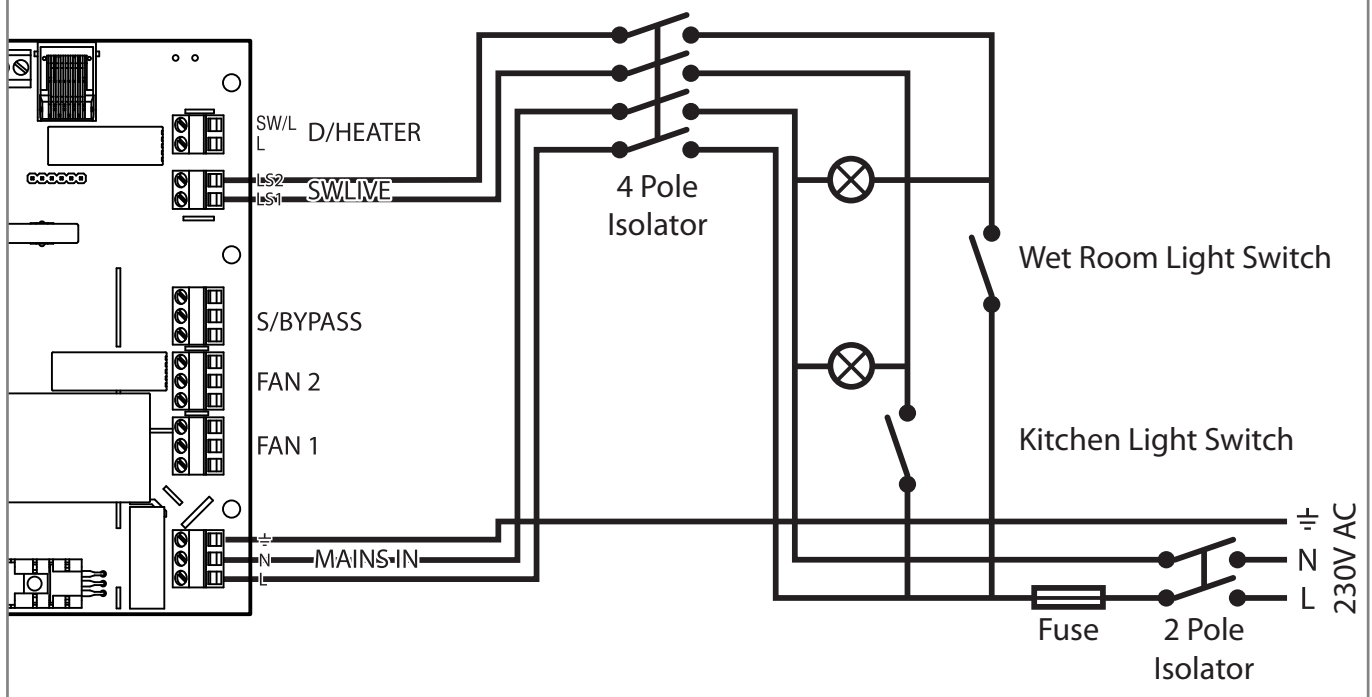

Supply wiring with switch inputs Ref EE166

Wiring Diagrams

Switch Defaults

- SW1 - Volt Free - Kitchen Boost.
- SW2 - Volt Free - Wet Room Boost.
- SW3 - Volt Free - SUMMERboost Control.

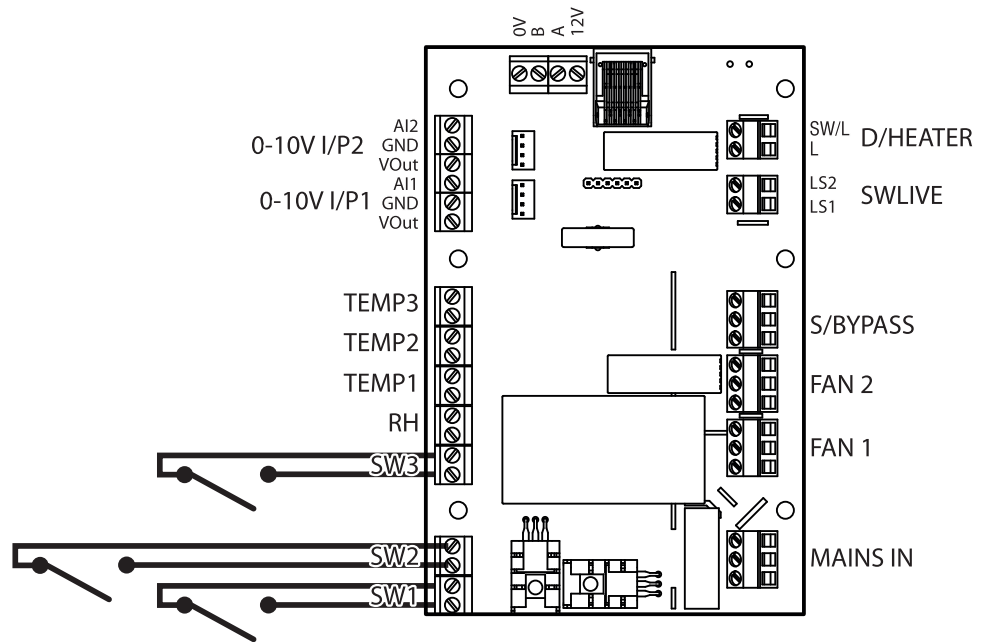

Volt Free switch inputs Ref EE163

Switch Defaults

- LS1 - 230V AC - Kitchen Boost
- LS2 - 230V AC - Wet Room Boost

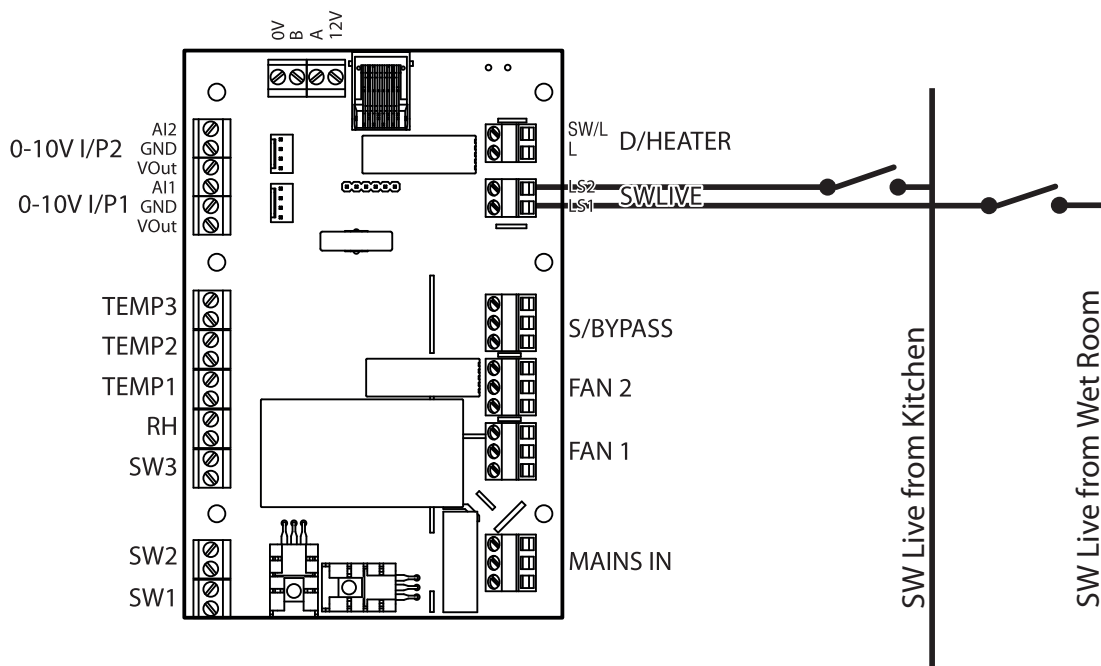

LIVE switch inputs Ref EE163

Wiring Diagrams

If sensors are fitted with switches ensure they are switched to VDC

Room Sensor 2
(default TP541 RSC Room CO₂ Sensor)

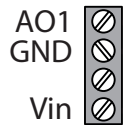

Room Sensor 1
(default TP542 RSH
Room Humidity Sensor)

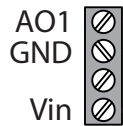

Additional Options:
TP540 RSQ Room Air Quality Sensor
TP543 RST Room Temperature Sensor

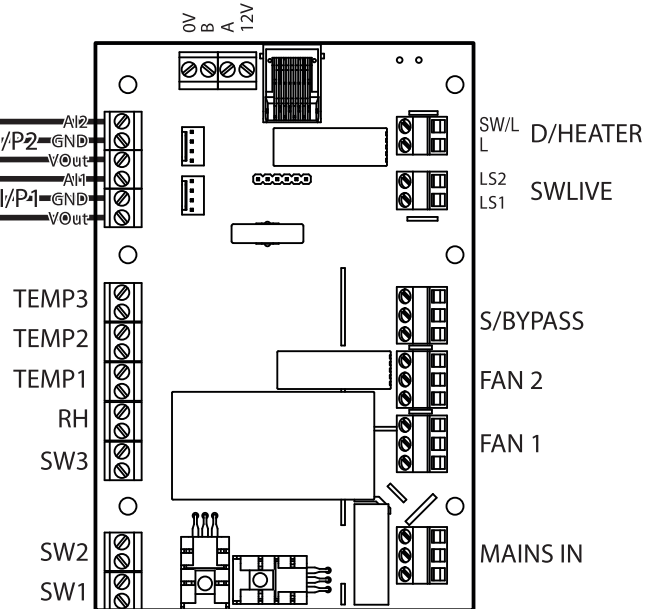

0-10V Sensor connections Ref EE161

Switch Positions TP508 Three Position Rotary Switch

- 1 - Setback Speed
- 2 - Continuous Speed
- 3 - Boost Speed

For this configuration to function correctly;
S1-1 Needs to be set to a Kitchen or Wet Room Boost switch,
S1-2 Needs to be set to a Setback switch.

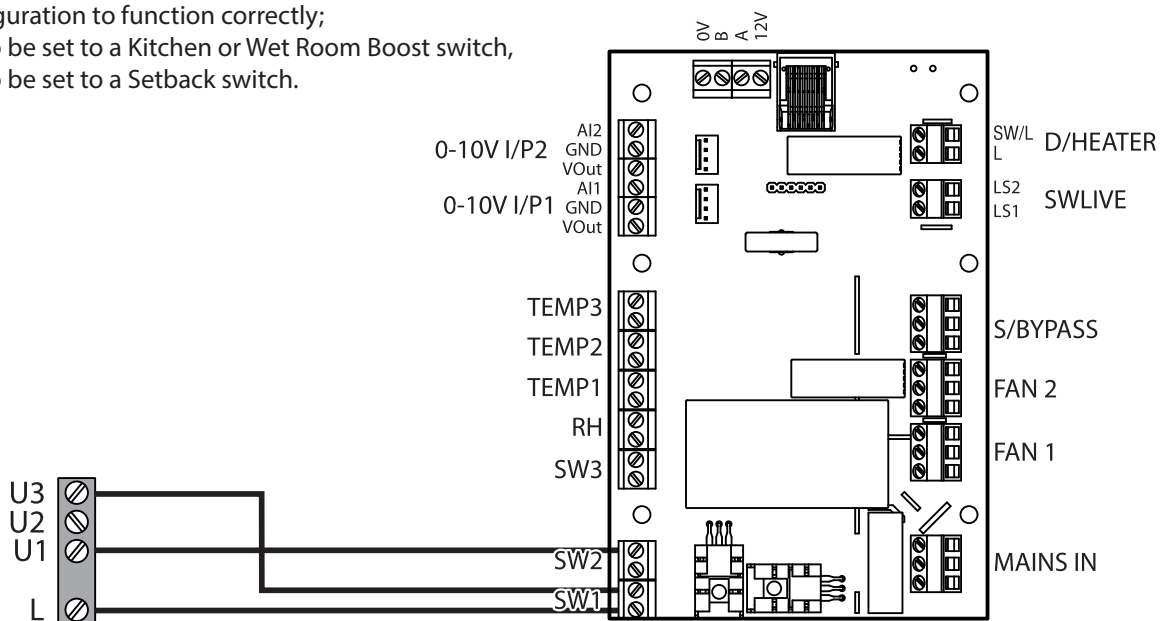

3-Way rotary switch Ref EE162

Wiring Diagrams

Any of these switch arrangements can be used in switch inputs SW1 to SW3 depending on their configuration and the type of MVHR.

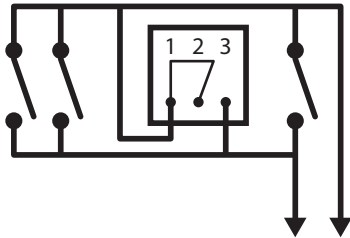

Volt-free boost switching of MVHR using single-pole switches TP502, TP503, TP507 and / or TP500/TP501 Humidistat.

There is a maximum of 10 single pole switches or Humidistats that can be used.



TP506 Latching Summer Mode switch / TP522 Latching SUMMERboost® switch.

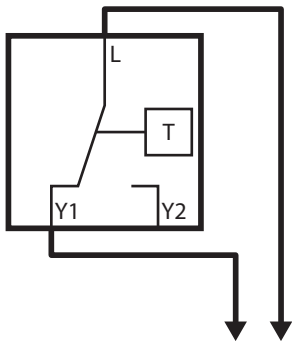

Volt-free control of SUMMERboost® using room thermostat. TP509 Room Thermostat

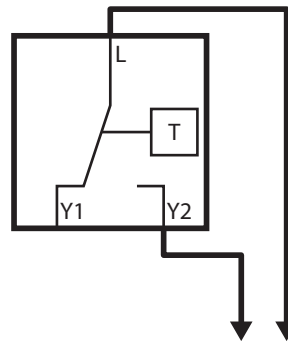

Volt-free activation of Summer Mode using room thermostat. TP509 Room Thermostat

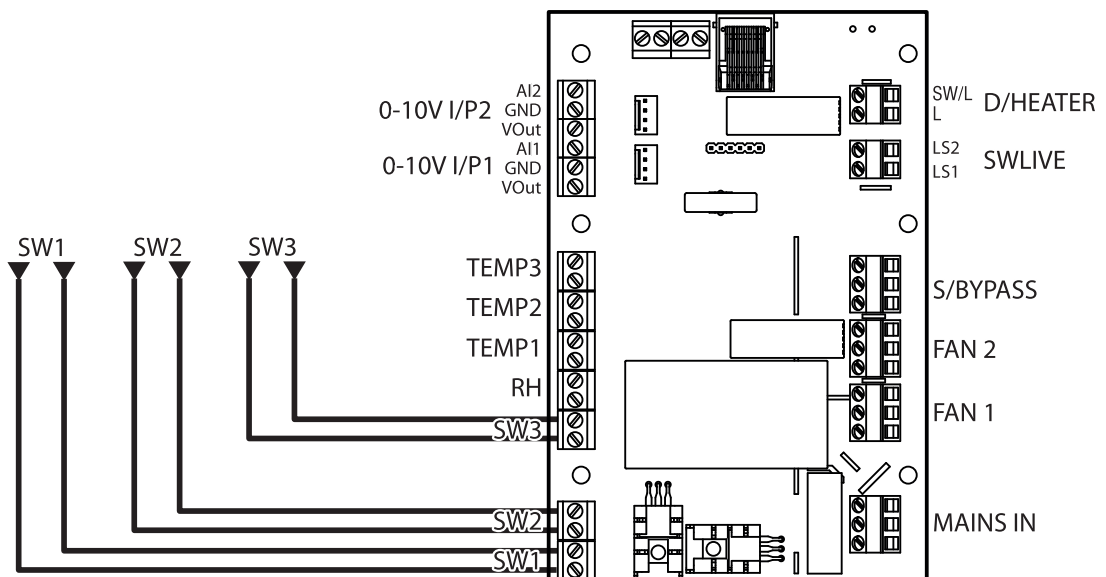

Duct Heater

Using the factory fitted PCB it is possible to control an external mains operated duct heater to pre-warm the incoming fresh air supply. During periods of cold weather, this reduces the possibility of ice build-up within the unit by raising the temperature of the incoming supply air. However there will be a significant increase in electrical energy use.

Fitting

1. The heater is designed for insertion into standard spiral steel ducting and is fixed to the ducting with screws.
2. The air must flow through the heater in the direction of the arrow (located on the side of the heater close to the connection box).
3. The heater can be fitted in either horizontal or vertical ducting. The electrical connection cabinet can be freely placed facing upwards or sideways to a maximum angle of 90°. Fitting with the box facing downwards is NOT allowed.
4. The access opening in the heater must be equipped with a fixed mesh or an intake air device which makes it impossible to touch the element inside.
5. A warning sign must be attached close to the air outlet, stating that the air outlet must not be covered.
6. The distance from (to) the heater to (from) a duct bend, valve, filter, etc should correspond to at least twice the duct diameter, otherwise there is a risk that the airflow through the heater is uneven which can cause activation of the overheating cut-out.



Duct Heater

7. The heaters may be insulated in accordance with valid regulations for ventilation ducting. However, the insulation material must be incombustible. The cover of the heater must be free from insulation so that the type plate is visible and the cover can be removed.
8. The parts of the ventilation system where heaters are installed must be kept accessible to allow replacement and service.
9. The distance from the heater's metal casing to any wood or other combustible material must NOT be less than 30 mm.
10. The maximum ambient temperature allowed is 40°C.
11. The air flow through the heater must have a speed of at least 1.5 m/s.
12. The maximum output temperature allowed is 40°C.

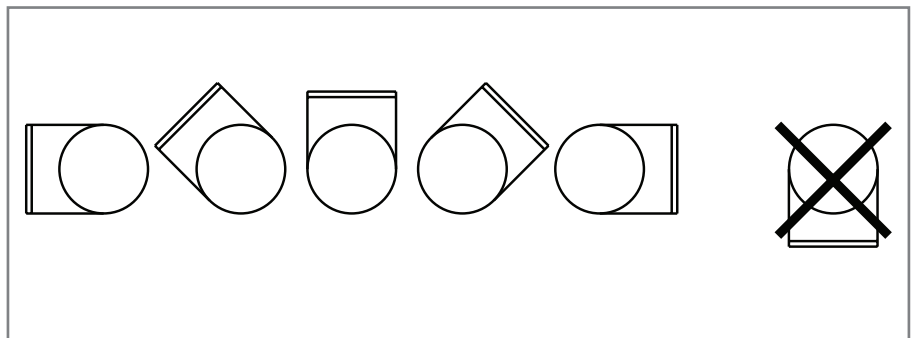

Duct Heater fitting orientation

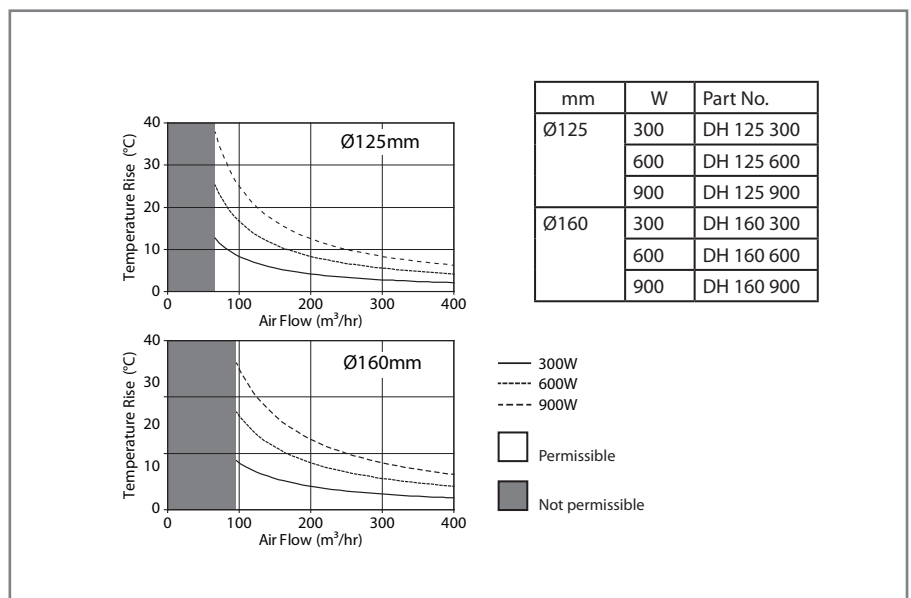

Duct Heater Operational Ranges

Connection to Mains

1. All wiring must conform to current I.E.E. Wiring Regulations and all applicable national standards and Building Regulations.
2. The installation MUST be carried out by a suitably qualified competent person.

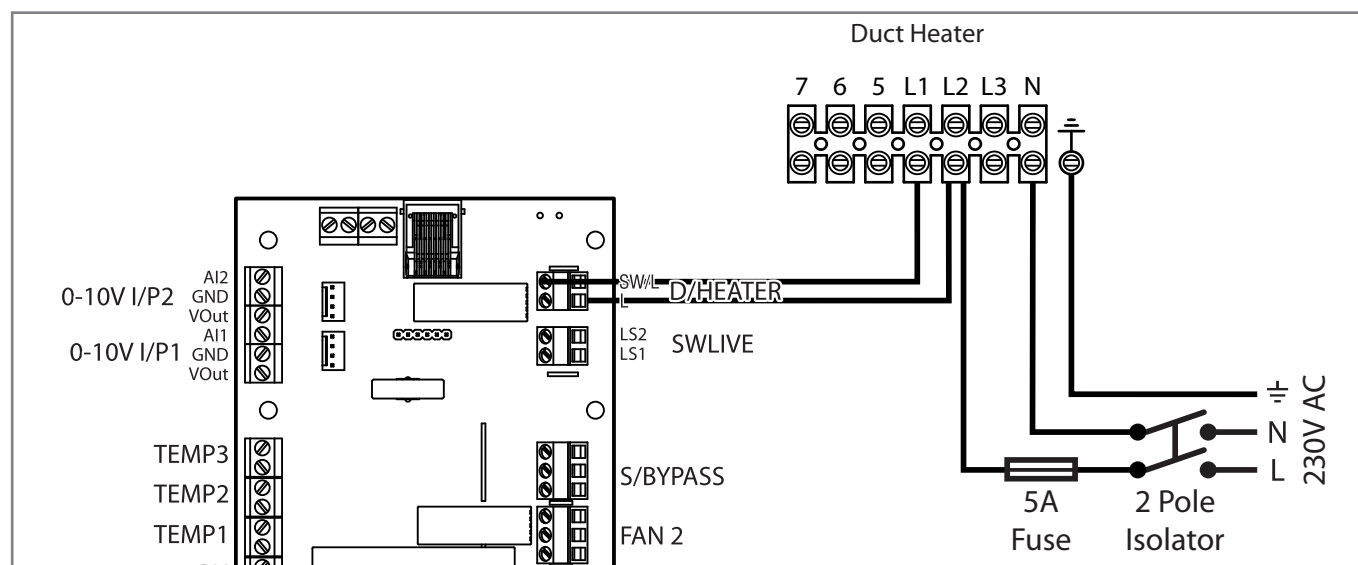

Duct Heater CV 12-09-1M Connection Wiring Diagram Ref EE165

3. The duct heaters are designed to operate on single phase alternating current. See the wiring diagram for the particular heater and the electrical data on the rating plate placed on the cover of the duct heater.
4. The duct heater must be connected to the mains supply with a fixed installed round cable. The heater must be equipped with a cable grommet or cable fitting designed for the cable, which ensures that the electrical protection class of the heater is retained. The standard design is IP43.
5. It must not be possible to switch on the power to the element unless the HRV10 *Q Plus* is operating. An all phase breaker or a double pole switch with a contact gap of at least 3mm must be included in the fixed installation.
6. The duct heater is equipped with two overheating cut-outs (one with manual reset) designed to prevent overheating when the airflow is too low or in the event of a fault in the system.
7. A drawing must be attached inside the fuse box or on the wall of the service room. The drawing shows the rating of the duct heaters and their location in the building, together with information about the measures to be taken in the event that the overheat protection cutout(s) is activated.

Maintenance

No maintenance is required except a periodic functional test.

Overheating

When the overheating cut-out with manual reset has been activated, the following should be observed:

1. The heater must not be interfered with in any way, such as removal of the cover, except by an authorised electrical fitter.
2. Turn off the mains power.
3. Investigate carefully the reason for activation of the cut-out.
4. When the fault has been eliminated, the cut-out can be reset.

The heater has a built in manual reset thermal protection with the reset button placed on the lid of the duct heater.

Routine Maintenance

All ventilation units require periodic maintenance. Routine maintenance, apart from filter changes, must only be carried out by a suitably qualified and competent person.

WARNING: The unit uses a 230V ~ supply and contains rotating mechanical parts. ISOLATE the unit from mains power supply and allow sufficient time for all moving parts to stop before undergoing any Servicing or Maintenance. The unit may be supplied with multiple live supply if a Duct Heater is fitted or uses switched live for Boost Speed control.

Front Cover Removal

1. ISOLATE the unit from mains power supply and allow sufficient time for all moving parts to stop
2. Loosen the two corner screws located on the bottom front of the unit
3. Completely remove the centre screw
4. Completely remove the Front Cover by pulling it away from the unit at the bottom and lifting

Cover replacement is the reverse of the above steps. Ensure it is securely located at the top before tightening screws.

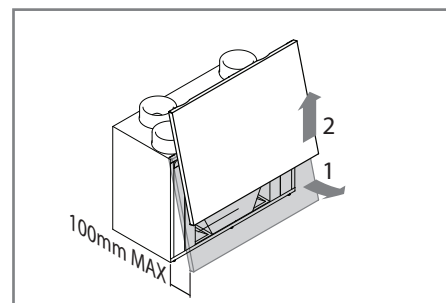
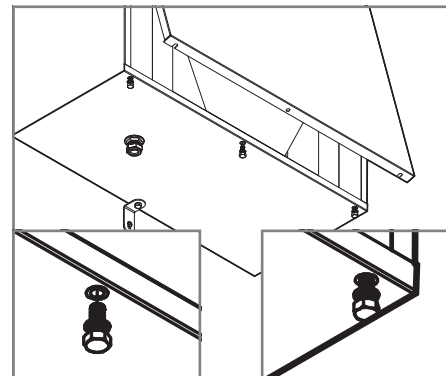

Cleaning Interior

For best results:

1. Slide out Filter Frames fitted either side of heat exchanger
2. Carefully remove any dust from face of heat exchanger, interior of the unit and the Bypass(if fitted) using a vacuum cleaner

Do not use water or any other fluids

Cleaning Exterior

For best results use a clean damp cloth. Do not use abrasive cleaners, solvents or any other fluids.

Condensate Tray

If the Condensate Tray is split a replacement must be ordered and fitted.

HRV1 & 1.25 Q Plus Part No. XP40042/012

HRV 1.75, 2, 2.85 & 3 Q Plus Part No. XP40142/012

Condensate Tray

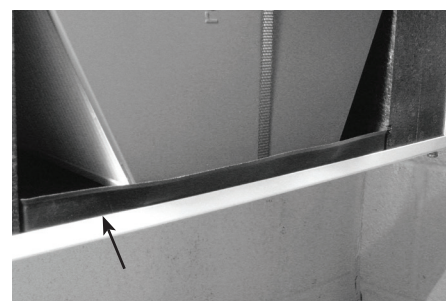

Filter Replacement



Filters should be replaced at least annually, or more regularly dependent on environmental conditions. The aurastat® will indicate filter change required in line with the Filter Change Interval setting. Replacement Filters are available from Titon Direct. www.titondirect.co.uk

Titon HRV *Q Plus* Filters are available in two grades G3 and G4. Filter media should be replaced like for like.

Filter Part numbers in table below. The Unit part number can be found on the serial number label fixed to the top and front of the unit.

G3 Filters - Both faces white.

G4 Filters - One face white, one face blue.

Model	Part Number	G3 Filter Set 2 framed filters	G4 Filters Set 2 framed filters
HRV1 <i>Q Plus</i>	TP410B	XP40032/099	XP46022/099
HRV1.25 <i>Q Plus</i>	TP416B		
HRV1.75 <i>Q Plus</i>	TP414B	XP40133/099	XP46133/099
HRV2 <i>Q Plus</i>	TP411B		
HRV2.85 <i>Q Plus</i>	TP417B		
HRV3 <i>Q Plus</i>	TP412B		

How to Change Filters

1. Remove Front Cover or Filter Covers.
2. Slide out Filters.
3. HRV 1.75, 2, 2.85 & 3 *Q Plus* models use unequal Filters. Make a note of which side of the unit the filter with the shorter filter media is. The positions of filters is mark on the units.

Shorter filter media

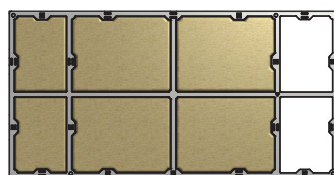

(HRV 1.75, 2, 2.85 & 3 *Q Plus*)

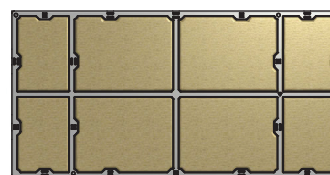

4. Replace Filters by carefully sliding in the replacement filters. Ensure that filters are replaced in the same positions as they were removed. The positions of filters is mark on the units.
5. Replace the Front Cover or Filter Covers.

In the event of any queries please contact the system installer.

Ensure this booklet is passed to the householder once installation & commissioning of the ventilation system is complete. This Product Manual must be kept in the Home Information Pack and used as a service record.

Installed by:



MARKETING DIVISION
International House, Peartree Road, Stanway, Colchester, Essex CO3 0JL
Tel: +44 (0) 1206 713800 Fax: +44 (0) 1206 543126
Email: ventsales@titon.co.uk Web: www.titon.com