

Section HMB/HMBE

auralite® compatible HRV units

HRV1.25 <i>Q Plus</i> ECO	TP406HMB
HRV1.35 <i>Q Plus</i> ECO	TP408HMB
HRV1.75 <i>Q Plus</i> ECO	TP404HMB
HRV2 <i>Q Plus</i> ECO	TP401HMB
HRV2.85 <i>Q Plus</i> ECO	TP407HMB
HRV3 <i>Q Plus</i> ECO	TP402HMB

HRV1.35 <i>Q Plus</i> ECO Enthalpy	TP408HMBE
HRV2 <i>Q Plus</i> ECO Enthalpy	TP401HMBE

Section B/BE

aurastat® and auramode® compatible HRV units

HRV1.25 <i>Q Plus</i> ECO	TP416B
HRV1.35 <i>Q Plus</i> ECO	TP418B
HRV1.75 <i>Q Plus</i> ECO	TP414B
HRV2 <i>Q Plus</i> ECO	TP411B
HRV2.85 <i>Q Plus</i> ECO	TP417B
HRV3 <i>Q Plus</i> ECO	TP412B

HRV1.35 <i>Q Plus</i> ECO Enthalpy	TP418BE
HRV2 <i>Q Plus</i> ECO Enthalpy	TP411BE
HRV3 <i>Q Plus</i> ECO Enthalpy	TP412BE

Heat Recovery Ventilation Units

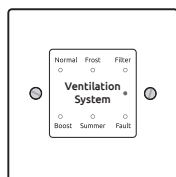

Compatible with HMB units

auralite®

TP518

LED Status Indicator

Product Manual



Warnings, Safety Information and Guidance

Important Information

Important: read these instructions fully before the installation of this appliance

1. Installation of the appliance and accessories must be carried out by a qualified and suitable competent person and be carried out in clean, dry conditions where dust and humidity are at minimal levels.
2. This manual covers the installation of the Heat Recovery Ventilation (HRV) unit
3. All wiring must conform to current I.E.E. Wiring Regulations and all applicable standards and Building Regulations.
4. Inspect the appliance and electrical supply cord. If the supply cord is damaged, it must be replaced by the manufacturer, their service agent or similarly qualified persons in order to avoid a hazard.
5. The unit is supplied with a mains rated 3 core flexible cord (PVC sheathed, brown, blue and green/yellow 0.75mm²).
6. The appliance must be connected to a local double pole isolation switch with a contact separation of at least 3mm.
7. The appliance must be earthed.
8. HRV1.25, 1.35, 1.75, 2 & 2.85 Q Plus units suitable for 230V ~ 50/60Hz single phase with a fuse rating of 3A.
9. HRV3 Q Plus suitable for 230V ~ 50/60Hz single phase with a fuse rating of 5A.
10. auralite® & aurastat®, control & communication cable access is via the fitted cable gland(s) which are suitable for Ø3- 6mm cable.
11. auralite® & aurastat® control & communication cable - Unshielded 4 Core 18-24AWG Stranded, Tinned Copper.
12. Control & communication cables should not be placed within 50mm or on the same metal cable tray as any 230V~ lighting or power cables.
13. Ensure all cable glands are fully tightened.
14. The unit must be stored in a clean and dry environment. Do not install the appliance in areas where the following may be present or occur;
 - Excessive oil or a grease laden atmosphere,
 - Corrosive or flammable gases, liquids or vapours,
 - Ambient temperatures above 40°C or below -5°C,
 - Humidity levels above 90% or is a wet environment.
15. The appliance is not suitable for installation to the exterior of the dwelling.
16. This appliance can be used by children aged from 8 years and above and persons with reduced physical, sensory or mental capabilities or lack of experience and knowledge if they have been given supervision or instruction concerning use of the appliance in a safe way and understand the hazards involved. Children should be supervised to ensure that they do not play with the appliance. Cleaning and user maintenance shall not be made by children without supervision.
17. Ensure that external grilles are located away from any flue outlet, in accordance with relevant Building Regulations.
18. The unit must not be connected to a tumble dryer or a cooker hood.
19. Precautions must be taken to avoid the back-flow of gases into the room from an open flue appliance.
20. Ensure all ducting, condensate drain and associated pipe work is free from debris and blockages before switching on the unit

Explanation of symbols on the appliance.



Read instruction Manual.



Risk of Electric Shock.



General hazard safety alert.



Disconnect the mains supply before removing this cover.

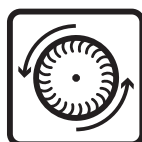

Wait until all machine components have completely stopped before touching them.

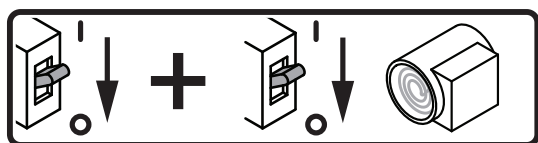

Disconnect the mains supply before removing this cover.

&

Before obtaining access to terminals or removing this cover, all supply circuits must be disconnected.

Titon Recommend:

1. A short piece of flexible ducting, approximately 200mm long is used to connect the unit to the ducting system.
2. Any flexible ducting used must be pulled taut.
3. A minimum distance of 200mm between the HRV unit and any sharp bends in duct work.
4. Ducting should be insulated where it passes through unheated areas and voids with the equivalent of at least 25 mm of a material having a thermal conductivity of $\leq 0.04 \text{ W/(m.K)}$ to reduce the possibility of condensation forming. Where a duct extends externally above roof level the section above the roof should be insulated or a condensate trap should be fitted just below roof level.
5. Ducts within the building heated envelope between the external terminals and the unit's From Atmosphere and To Atmosphere ports should be insulated and wrapped additionally with a vapour barrier outside the insulation.
6. Where ducts pass through fire barriers, they must be appropriately fire stopped in accordance with the requirements of Building Regulations.
7. A ducting condensate drain must be fitted to vertical To Atmosphere duct work.
8. Ducting must be installed in such a way that resistance to airflow is minimised.
9. Ducting connected to the From Atmosphere & To Atmosphere ports, must be to/from the external air outside the building envelope.
10. Duct joints to the unit's duct ports must be fixed using a method that ensures a long term seal is achieved. If using a short piece of flexible ducting secure using a hose clamp, do not over tighten.
11. A minimum distance of 2m exists between the external supply and exhaust terminals .

Warnings, Safety Information and Guidance

Important Information	2
Explanation of symbols on the appliance	3
Titon Recommend:	3

Product Information

Packaging Contents	5
Dimensions	6
HRV1.25 & 1.35 <i>Q Plus</i>	6
HRV 1.75, 2, 2.85 & 3 <i>Q Plus</i>	6

Installation

HRV1.25, 1.35, 1.75, 2, 2.85 & 3 <i>Q Plus</i>	7
Condensate Drain	8
Ducting Connections	9
Wiring Connections Access	9

Section TPxxxHMB/HMBE Product Overview

Controls & Features	10
Filter Covers	10
auralite®	10
Auto Setback Speed	10
Continuous Speed	10
Boost Speed with Overrun Timer	10
auralite® Boost Alert	11
Summer Bypass	11
SUMMERboost®	11
Automatic Frost Protection	11
Integrated Humidity Sensor	11
Enthalpy humidity-recovery	11
Wiring Diagrams	13
Supply	13
auralite®	13
Switching & Controls	14

Commissioning Units TPxxxHMB/HMBE

Controls	16
Control Parameters	16
Continuous Supply & Extract Speeds:	16
Boost Supply & Extract Speeds:	16
Boost Overrun	17
Humidity Sensor	17
Controller Reset	17
Hardware Reset	17

Section TPxxxB/BE Product Overview

Control & Features	18
Enthalpy humidity-recovery	18
Boost Overrun Timer	18
Boost Delay Timer	18
Boost Inhibit	18
Internal Humidity Sensor	18
Filter Change Alert	18
4 x Fan Speeds	18
Summer Mode	18
SUMMERboost®	18
Summer By Pass	18
Duct Heater Control	18
2 x Proportional Sensor Inputs	18
3 x Volt Free Inputs	18
2 x Live Switch Inputs	18
Frost Protection Program	18
Multiple Internal Temperature Sensors	18
Wiring Diagrams TPxxx B/BE Units	19
Supply	19
Switching & Controls	20
External Sensors	22
Duct Heater	24
Fitting	24
Duct Heater	24
Fitting	24
Connection to Mains	25
Maintenance	25
Overheating	25

Commissioning Units TPxxxB/BE

HRV Controller Options Manual	26
-------------------------------------	----

Maintenance

Routine Maintenance	28
Front Cover Removal	28
Cleaning Interior	28
Cleaning Exterior	28
Condensate Tray	28
Filter Replacement	29
How to Change Filters	29

The HRVs are Mechanical Ventilation with Heat Recovery (MVHR) units. They are designed for the energy efficient ventilation of dwellings. The units are designed for continuous ventilation, exhausting stale moist air from bathrooms, toilets, kitchen and utility rooms. As the stale air is extracted, the unit's heat exchanger transfers heat, which would have been wasted, to the fresh air being supplied to the bedrooms and living rooms.

Packaging Contents

Inspect the unit when taking delivery. Check the unit for damage and that all accessories have been supplied. Package supplied with;

- HRV unit x 1.
- Mounting Bracket x 2.
- Safety Bracket x 1.
- 15mm Condensate Drain Olive & Nut x 1.
- M6x10mm Pan head screws x 4.
- M6 washers x 4.
- Transport Bungs x 4, supplied packed in Duct Ports.
- Product Manual x 1.
- EuP Documentation.

Any shortages or damage must be immediately reported to the supplier.



When this document is viewed as a PDF the headings & sub headings on this page are hyper links to the content. Additionally the page numbers in this document are hyper links back to this contents page.

Dimensions

HRV1.25 & 1.35 Q Plus

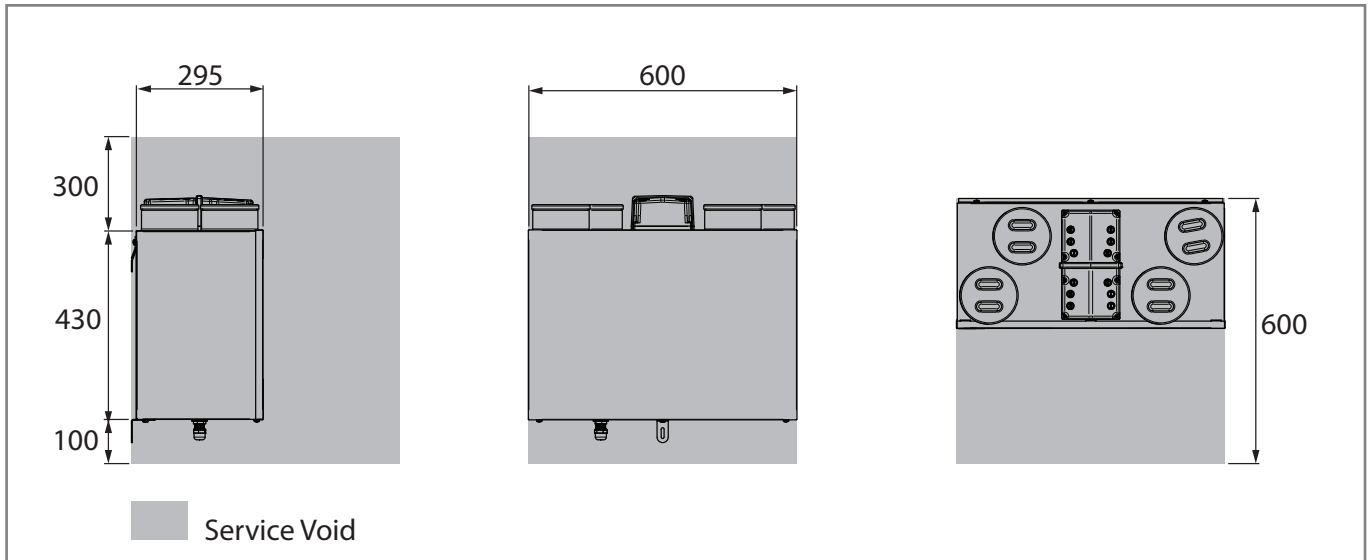

DO NOT BOX IN UNIT

HRV 1.75, 2, 2.85 & 3 Q Plus

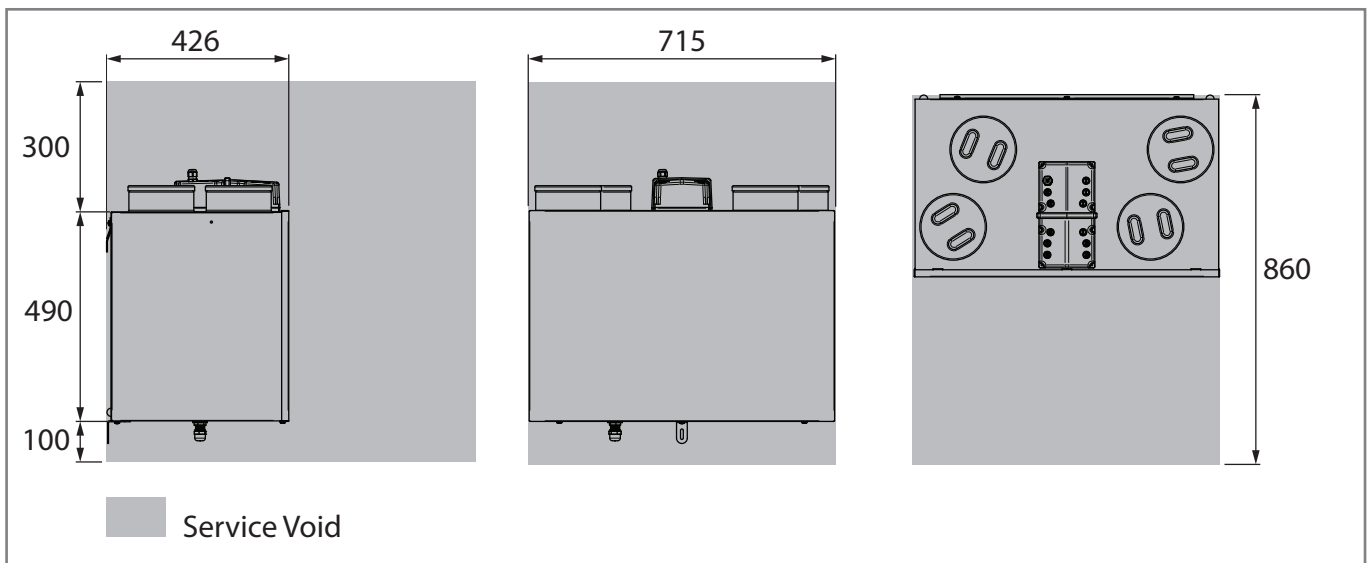

DO NOT BOX IN UNIT

HRV1.25, 1.35, 1.75, 2, 2.85 & 3 Q Plus

Read and observe the guidance & safety notices listed in Warnings, Safety Information and Guidance .

Do not remove the Port Covers until connecting ducting. Port Covers are fitted to prevent debris falling into the unit and causing blockages and damage:

- The Titon HRV *Q Plus* is designed to be mounted on a wall or similar. The mounting surface must be sufficiently strong to support the unit.
- Consider the positioning of electrical services and the Condensate Drain when siting the unit.
- Ensure there is sufficient access around the HRV *Q Plus* for future maintenance.
- Do not 'box-in' the unit making access to the unit difficult for maintenance and repair.

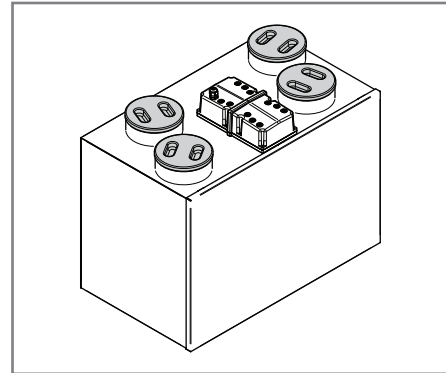

The Unit Must be mounted plumb and level front to back and side to side.

1. Mark a horizontal line on the wall using a spirit level. This line will be approximately 95mm below the location of the top face of the unit when fitted (excluding duct ports)
2. Use one of the Mounting Brackets as a template to mark the three fixing hole centres
3. Drill holes for fixings, always use a fixing suited to the wall type
4. Fix one Mounting Bracket to the wall ensuring the interlocking side is at the top, as shown
5. Fix the remaining Mounting Bracket to the unit using the M6 screws and washers provided, ensuring the interlock side is at the bottom. Do not overtighten
6. Mount the unit by locating the two Mounting Brackets together. Ensure a positive location is made between the two Mounting Bracket
7. The Safety Bracket **MUST** be fitted. Fix the lower Safety Bracket as shown using the remaining M6 screw, washer and suitable wall fixing. Packing to be used as required behind the Safety Bracket to ensure unit is level

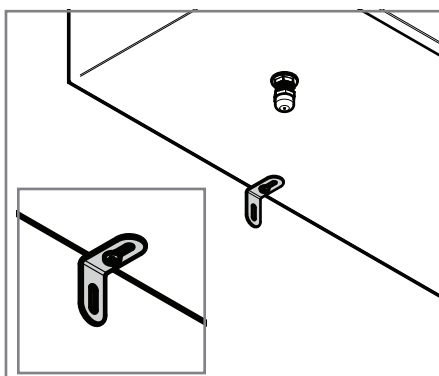
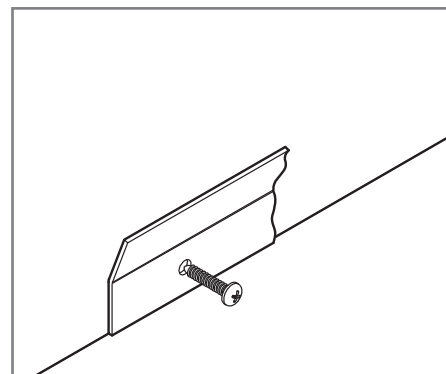
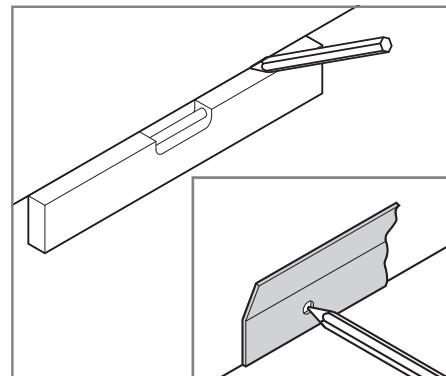

Safety Bracket highlighted

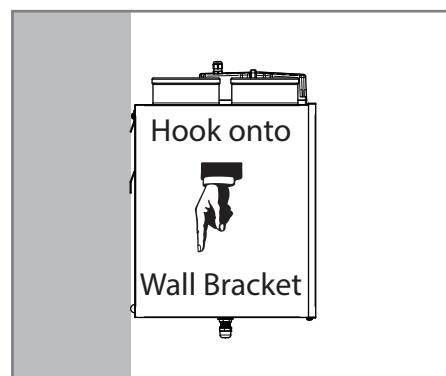

Condensate Drain

The unit's Condensation Drain Pipe must be fitted and connected to the dwelling's foul water drainage system in accordance with the relevant building regulations.

The Condensation Drain Pipe:

- Is attach via a 15mm compression fitting (drain pipe shown un-insulated for clarity), on the base of the unit
- Must incorporate a suitable trap, which must act as an air lock
- Must be adequate secured and be insulated with the equivalent of at least 25mm of insulating material with a thermal conductivity of 0.04 W/(mK) if any part of the pipe passes through an unheated void
- Should be installed to have a minimum 5° fall from the unit
- Titon recommend the use of diaphragm type waste valve in place of a conventional 'wet' trap which could dry out. Such as, BRE certificate no. 042/97 'Hepworth Hepv0 Hygienic self sealing plastic waste valve' recommended as an alternative to traditional U-Traps

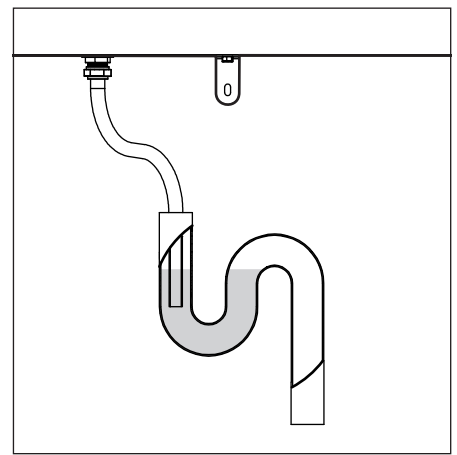
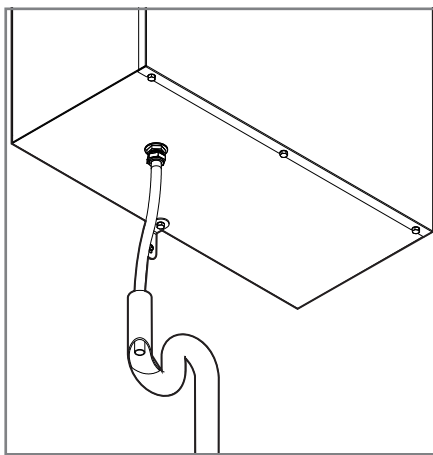

Ducting Connections

Read and observe the Warnings, Safety Information and Guidance.

The HRV unit has a labels with the icons indicating which port is which.

It is very important that ducting is connected to the correct ports in line with the icons below.



EXTRACT FROM DWELLING - This duct port is connected to the ducting that carries waste air from the 'Wet Rooms' to the HRV unit.



TO ATMOSPHERE - This duct port is connected to the ducting that carries the waste air to outdoors from the HRV unit.



SUPPLY TO DWELLING - This duct port is connected to the ducting that carries the fresh warmed air to the habitable rooms from the HRV unit.



FROM ATMOSPHERE - This duct port is connected to the ducting that carries fresh outdoor air to the HRV unit.

Wiring Connections Access

All wiring must conform to current I.E.E. Wiring Regulations and all applicable national standards and Building Regulations. Read and observe the Warnings, Safety Information and Guidance.

The electronics compartment is mounted on top of the unit. The compartment has two removable lids, front & rear. The front lid must always be removed before the rear lid; both lids are fixed by four screws. All wiring must be routed into the electronics compartment via the knock-outs and using cable glands or similar.

Section TPxxxHMB/HMBE Product Overview

Controls & Features

The auralite HRV *Q Plus* units are controllable by various volt free switches and sensors. The following describes the controls and features of the auralite HRV *Q Plus* units and how they are controlled. Ensure all controls are adequately labelled, indicating their function clearly.

Filter Covers

The units are fitted with removable filter covers on the front panel.

auralite®

auralite® is available separately as an optional add-on. auralite® is a low voltage hard wired remote LED ventilation system status indicator, designed to fit a standard UK patress or recessed backbox. The indicator has six LEDs which display:-

- Normal Solid light - Unit is running at Continuous Speed.
 Flashing light - Unit is running at Setback Speed.
- Frost Unit is in Automatic Frost Protection mode.
- Filter Filters require change.

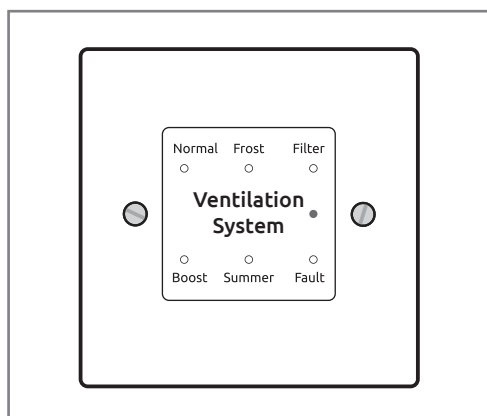

auralite® Indicator Panel

- Boost Solid light - Unit is running at Boost Speed.
 Flashing light Boost Alert is active.
- Summer Unit is in Summer bypass.
- Fault Unit has a fault - Contact the installer.

Auto Setback Speed

Setback Speed is used to reduce ventilation rates. Setback Speed is automatically set at the mid point between minimum possible Continuous Speed and the selected Continuous Speed. The Setback Speed can be enabled by connection of a volt free one-way switch, or combined with the Boost Speed with the 3 position switch TP 508.

Continuous Speed

Continuous Speed is the normal continuous extract and supply air flow running speed of the units.

Boost Speed with Overrun Timer

Boost Speed increases the extract and supply air flow. Boost Speed is configured with Step-less independent fan controls and includes an Overrun Timer variable between 0 and 60 minutes. The Boost Speed can be triggered by any device which provides a volt free one-way switch, such as a PIR, thermostat, humidistat or a standard one-way switch. If the unit is left Boost (latching switch) for longer than 2 hours the Overrun Timer is disabled meaning the HRV will return to Continuous Speed as soon as the switch holding the unit in Boost is released.

auralite® Boost Alert

Boost Alert is a timer designed to prevent the HRV being inadvertently left in Boost for long periods of time. Once the HRV is placed in Boost the timer is started and after 2 hours Boost Alert will be activated. This is indicated by the Boost LED on the auralite® Indicator Panel flashing. Once Boost Alert has been activated the Overrun Timer is disabled meaning the HRV will return to Continuous Speed as soon as the switch holding the unit in Boost is released.

Summer Bypass

Summer Bypass is designed to operate during hot periods where fresh air can be vented straight into the property without being preheated by the extracted stale air. Summer Bypass operation is automatically controlled. The Summer Bypass mechanism diverts the stale air being extracted from the dwelling around the heat cell so that its heat energy is not transferred to the fresh air being supplied to the property.

SUMMERboost®

An optional SUMMERboost® facility is available that allows both the supply and extract fans to run at full speed whenever the Summer Bypass is activated.

By default SUMMERboost® is disabled by a Link Wire, see Wiring Diagrams.

Removal of the link wire will enable SUMMERboost®.

When SUMMERboost® is triggered by Summer Bypass the increased fan speed can be prevented either Manually or Automatically.

Manual - This is by means of a volt-free switch wired directly into the controller PCB.

Automatic - This is by means of a dedicated wall mounted room thermostat. SUMMERboost® will only operate when the temperature has exceeded the thermostat setting. Should the room temperature fall below the thermostat setting, then SUMMERboost® will not operate.

Automatic Frost Protection

During very cold weather, Automatic Frost Protection will detect temperatures that could form ice inside the unit. It will reduce the supply ventilation rate to prevent ice build up within the heat cell. Automatic Frost Protection reduces the flow rate of cold air, thus allowing the warmer stale air to raise the temperature within the heat cell to such a level that prevents the formation of ice. As internal temperatures rise Automatic Frost Protection will increase the supply ventilation flow rate back to the commissioned settings.

Integrated Humidity Sensor

Units are fitted with an Integrated Humidity Sensor. This continuously monitors the relative humidity (RH) of the extracted air and triggers Boost Speed when the relative humidity rises over the set threshold. The Humidity Sensor's trigger point is variable from 55%RH to 85%RH and is configured using step-less independent potentiometer.

Enthalpy humidity-recovery

Units with the E suffix use an enthalpy heat recovery core that recovers some of the humidity as well as heat.



TPxxxHMB/HMBE Units ONLY

Wiring Diagrams

Supply

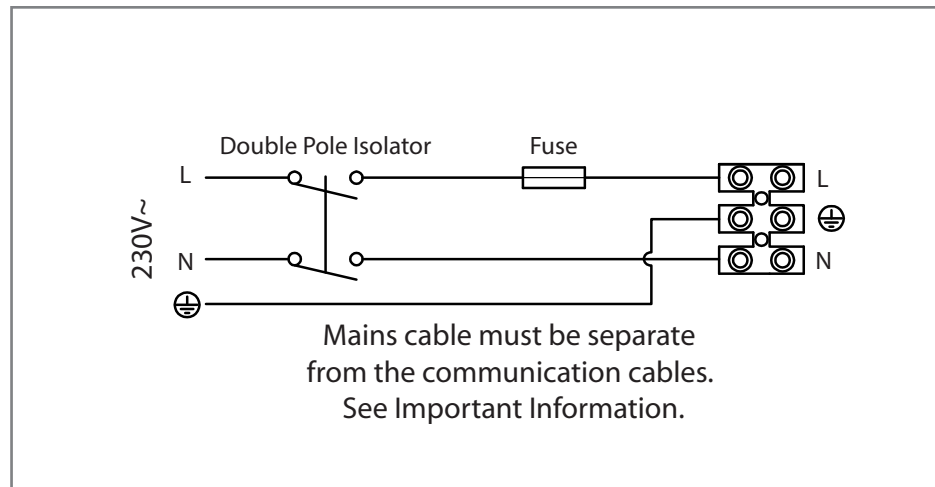

Supply wiring diagram 230V~ ref EE141

auralite®

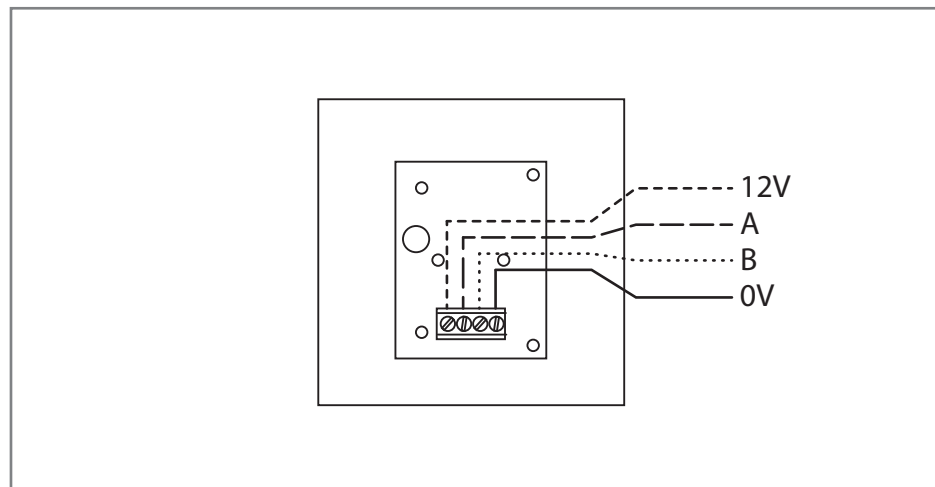

auralite® connection at Indicator ref EE180

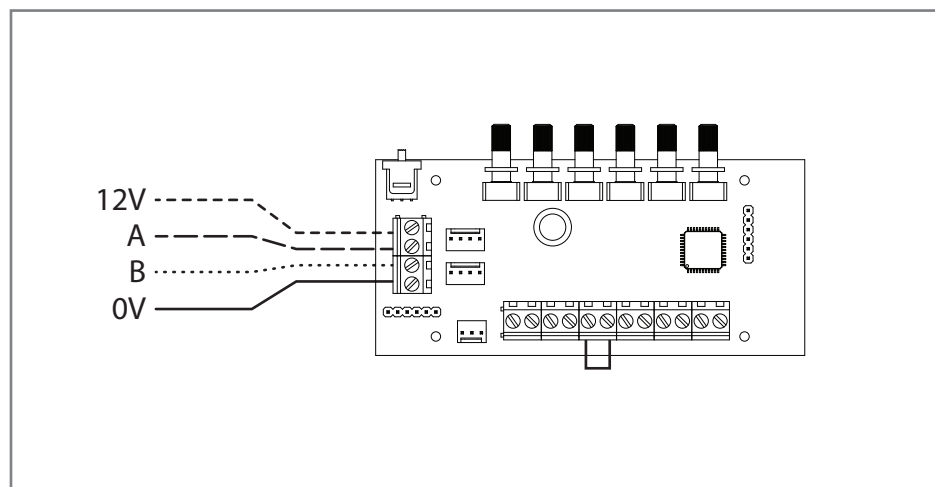

auralite® connection at Unit ref EE180

TPxxx HMB/BE Units ONLY

Switching & Controls

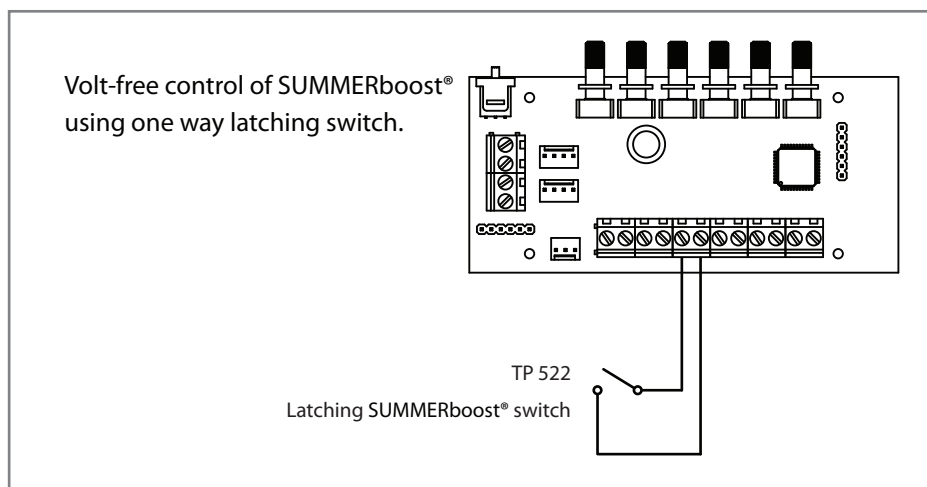

SUMMERboost® switch connection ref EE178

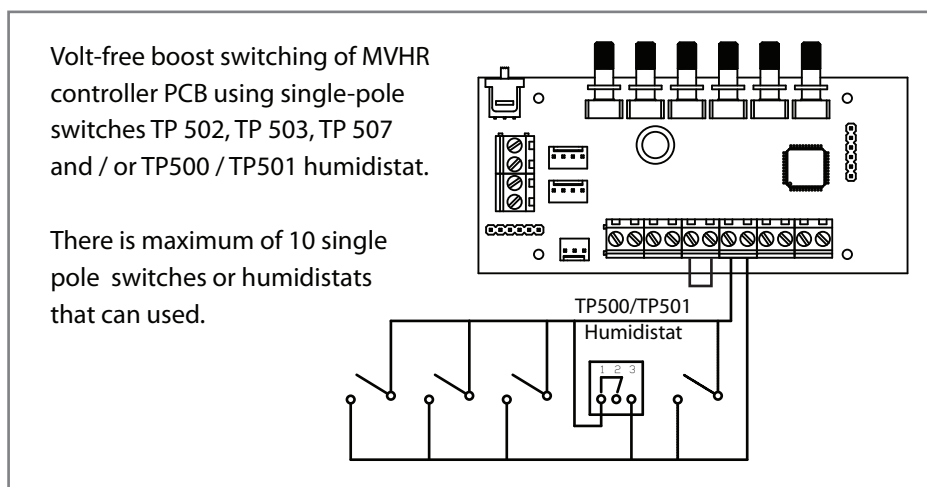

Boost switching and Humidistat connection ref EE173

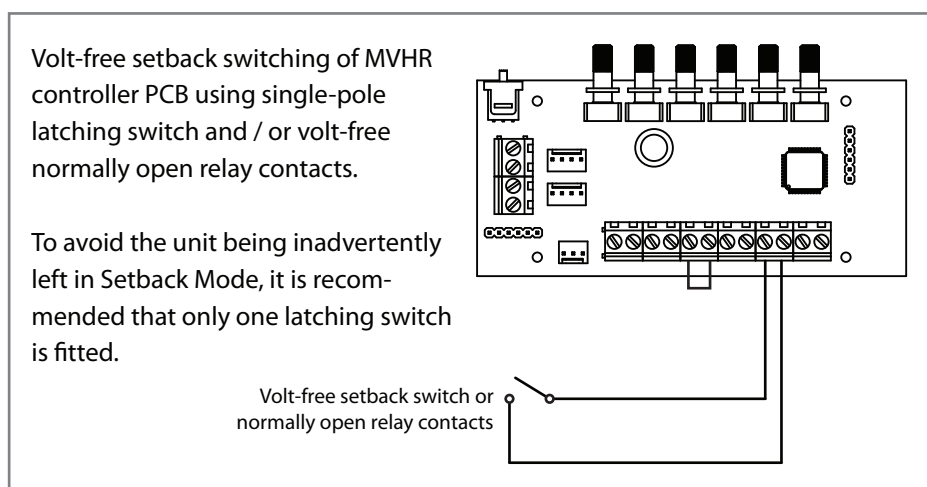

Setback Mode switching and connection ref EE177

TPxxx HMB/HMBE Units ONLY

SWITCH POSITIONS

- 1 - Setback Speed
- 2 - Continuous Speed
- 3 - Boost Speed

TP 508
Three position rotary switch

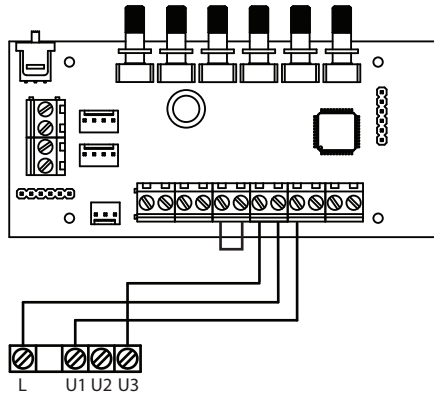

Three Position Rotary Switch TP 508 switching and connection ref EE175

SUMMERboost® Link Wire must be removed to enable SUMMERboost®.

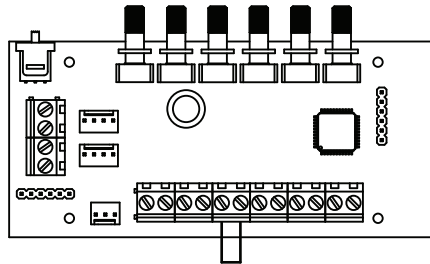

SUMMERboost® Link Wire

SUMMERboost® Link Wire

Volt-free control of SUMMERboost® using room thermostat.

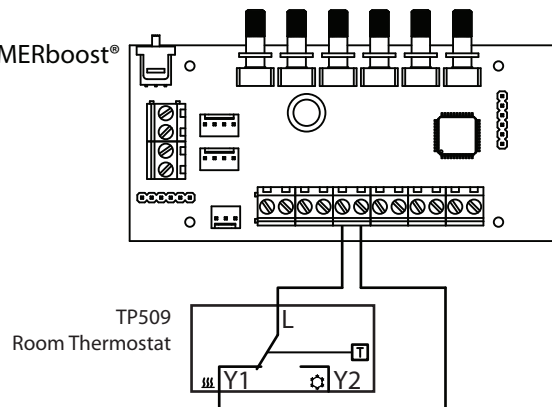

SUMMERboost® thermostat connection ref EE178

Commissioning Units TPxxxHMB/HMBE

Controls

The fan speeds of the Titon HRV *Q Plus* will require adjustment to ensure the flow rates achieved provide adequate ventilation. The Titon HRV *Q Plus* has 2 standard fan speed settings Continuous Speed and Boost Speed.

The Continuous Speed and Boost Speed are programmed by placing the controller into Program Mode via the Program/Run Switch and changing the position of rotary potentiometers.

When applying power for the first time, the unit can take up to four minutes to start operating.

Prior to the first commission set Continuous Speed potentiometers to minimum and Boost Speed potentiometers to maximum or reset the controller.

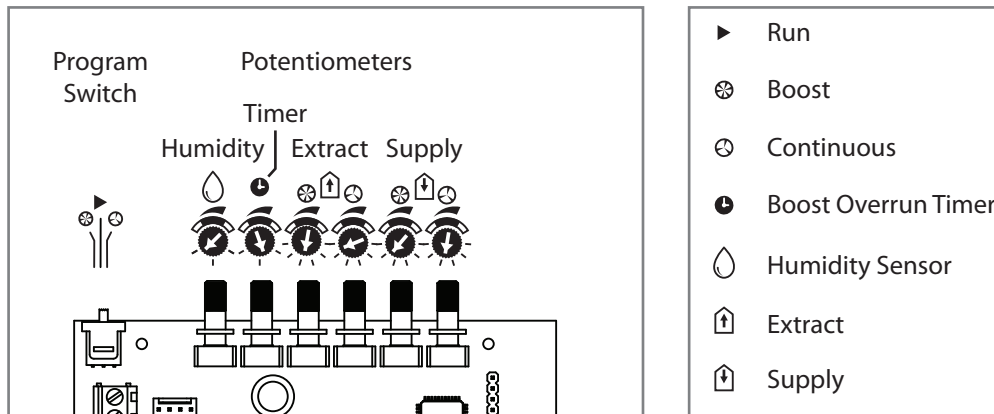

Control Identification

Control Parameters

- The Boost Speed cannot be set lower than the Continuous Speed.
- The Continuous Speed cannot be set higher than the Boost Speed.
- All switching inputs are disabled when the Program/Run Switch is in Continuous or Boost positions.
- Speed control potentiometers are disabled when the Program/Run switch is in centre Run position.

For the commissioning settings to be stored the unit needs to be powered up.

Continuous Supply & Extract Speeds:

1. Move Program/Run Switch to Continuous position.
2. Rotate supply fan Continuous Speed adjustment potentiometer to achieve required supply continuous air flow.
3. Rotate extract fan Continuous Speed adjustment potentiometer to achieve required extract continuous air flow.
4. Return Program/Run Switch to centre position to exit commissioning.

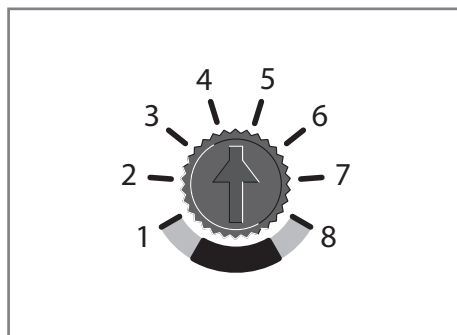

Commissioning Pot positions

Boost Supply & Extract Speeds:

1. Move Program/Run Switch to Boost position.
2. Rotate supply fan Boost Speed adjustment potentiometer to achieve required supply boost air flow.
3. Rotate extract fan Boost Speed adjustment potentiometer to achieve required extract boost air flow.
4. Return Program/Run Switch to centre position to exit commissioning.

Boost Overrun

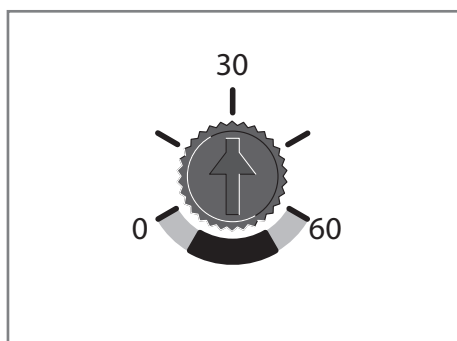

Boost Overrun Timer is variable between 0 and 60 minutes. Rotate potentiometer to change overrun time. This can be done at any time.

Humidity Sensor

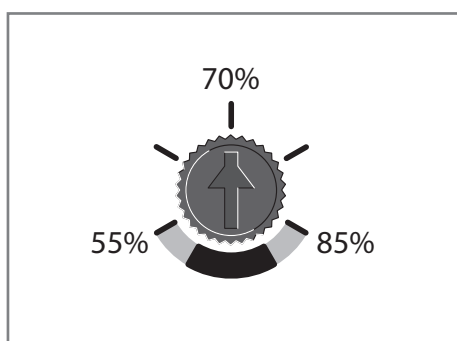

The Humidity Sensor's trigger point is variable from 55%RH to 85%RH. Rotate potentiometer to change trigger point. Humidity Sensor adjustment can be done at any time without the need to move the Program / Run Header Link.

Controller Reset

Following a controller reset the ventilation system will need to be fully commissioned.

The procedure to reset the Titon HRV *Q Plus* controller is a simple three step operation. The unit will need to be powered up during the reset procedure.

1. Rotate the Supply and Extract Continuous Speed potentiometers fully anti-clockwise.
2. Rotate Supply and Extract Boost Speed potentiometers fully clockwise move the Run/Program Switch from the Run position to the Continuous position, from the Continuous position to the Boost position and back to the Run position. To ensure that the reset switch movements are registered by the controller wait two seconds between each switch movement. Controller reset is now complete.

Hardware Reset

Certain conditions (repeated supply interruptions etc.) can activate the automatic motor protection mode. Whereby the fan motors are prevented from operating. This requires a hardware reset to return the unit to normal operating mode, to achieve this power to the unit should be switched off for 5 minutes, restoring the power after this time will reset the hardware of both the motor and PCB. Commissioning settings are not affected during a hardware reset.

Section TPxxxB/BE Product Overview

Control & Features

The TPxxx B and BE units are programmable with the aurastat® or auramode® controllers.

Enthalpy humidity-recovery

Units with the E suffix use an enthalpy heat recovery core that recovers some of the humidity as well as heat.

Boost Overrun Timer

A programmable timer that controls the time the HRV remains at Boost Speed after all boost switches have been released.

Boost Delay Timer

A programmable timer which can be used to delay the HRV running at Boost Speed after a boost switch has been activated.

Boost Inhibit

A programmed time period that prevents the HRV switching into Boost Speed or SUMMERboost®.

Internal Humidity Sensor

The HRV has a relative humidity (RH) sensor. The RH sensor can be programmed to switch the HRV into Boost Speed.

Filter Change Alert

The unit can display a filter warning via a connected controller

4 x Fan Speeds

The units have 4 programmable speed settings. All speeds allow independent speed setting of both supply and extract ventilation rates

Summer Mode

Summer Mode operates by slowing or stopping the supply fan. This reduces the supply of From Atmosphere air to the dwelling. Summer Mode is triggered automatically or via a Volt

Free input. Summer Mode must not be enabled or installed in dwellings where open flue combustion appliances are used.

SUMMERboost®

SUMMERboost® allows both the supply and extract fans to run at full speed whenever the Summer Bypass is activated. By default SUMMERboost® is enabled.

Summer By Pass

Summer Bypass is designed to operate during hot periods where fresh air can be vented straight into the property without being preheated by the extracted stale air. Summer Bypass operation is automatically controlled. The Summer Bypass mechanism diverts the stale air being extracted from the dwelling around the heat cell so that its heat energy is not transferred to the fresh air being supplied to the dwelling.

Duct Heater Control

To maintain ventilation flow rates where prolonged periods of very low temperatures occur, the facility for the control of an electrically powered Duct Heater is provided, MAX 1000W. The Duct Heater is placed in-line between the outside supply vent and the From Atmosphere terminal on the HRV. In these applications, the heater is used to pre-warm the outside fresh air supply before it enters the HRV.

2 x Proportional Sensor Inputs

Enables connection of environmental sensors to the HRV which can be used to proportionally control HRV fan speeds.

3 x Volt Free Inputs

Enables the connection of single pole momentary switches, latching switches or normally open relay contacts to the HRV. These can be used to switch between fan speeds or control SUMMERboost® and Summer Mode.

2 x Live Switch Inputs

These inputs are used to switch the HRV to Boost Speed via a switched live input.

Frost Protection Program

During very cold weather, the Frost Protection Program will detect temperatures that could cause ice to form inside the unit. It will reduce or stop the supply ventilation rate, thus allowing the warmer stale air to raise the temperature within the unit cell to such a level that prevents the formation of ice. As temperatures rise the Frost Protection Program will increase the supply ventilation flow rate back to the commissioned settings.

Multiple Internal Temperature Sensors

The unit measures From Atmosphere and To Atmosphere air temperatures in real-time. Additionally the temperature of the heat cell is monitored.

TPxxx B/BE Units ONLY

Wiring Diagrams TPxxx B/BE Units

Supply

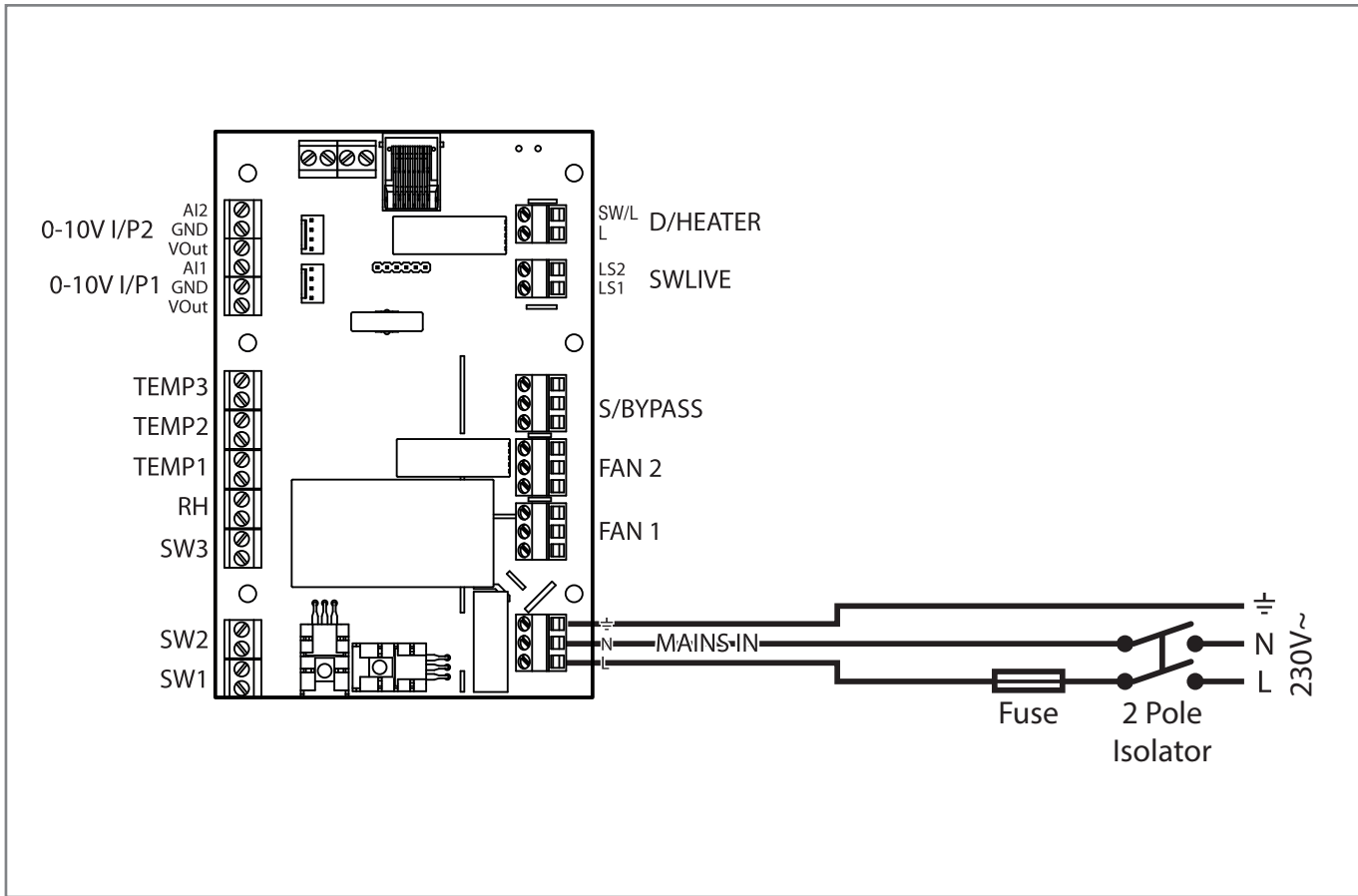

Supply wiring Ref EE167

TPxxxB/BE Units ONLY

Switching & Controls

The Switched Live (LS1, LS2) Boost(s) must be supplied via the same circuit as used to power the unit.
A 3 (LS1 only) or 4 (LS1 & LS2) pole local isolator must be installed. The Boxed Relay (Part No. TP505) may be required to switch from other circuits.

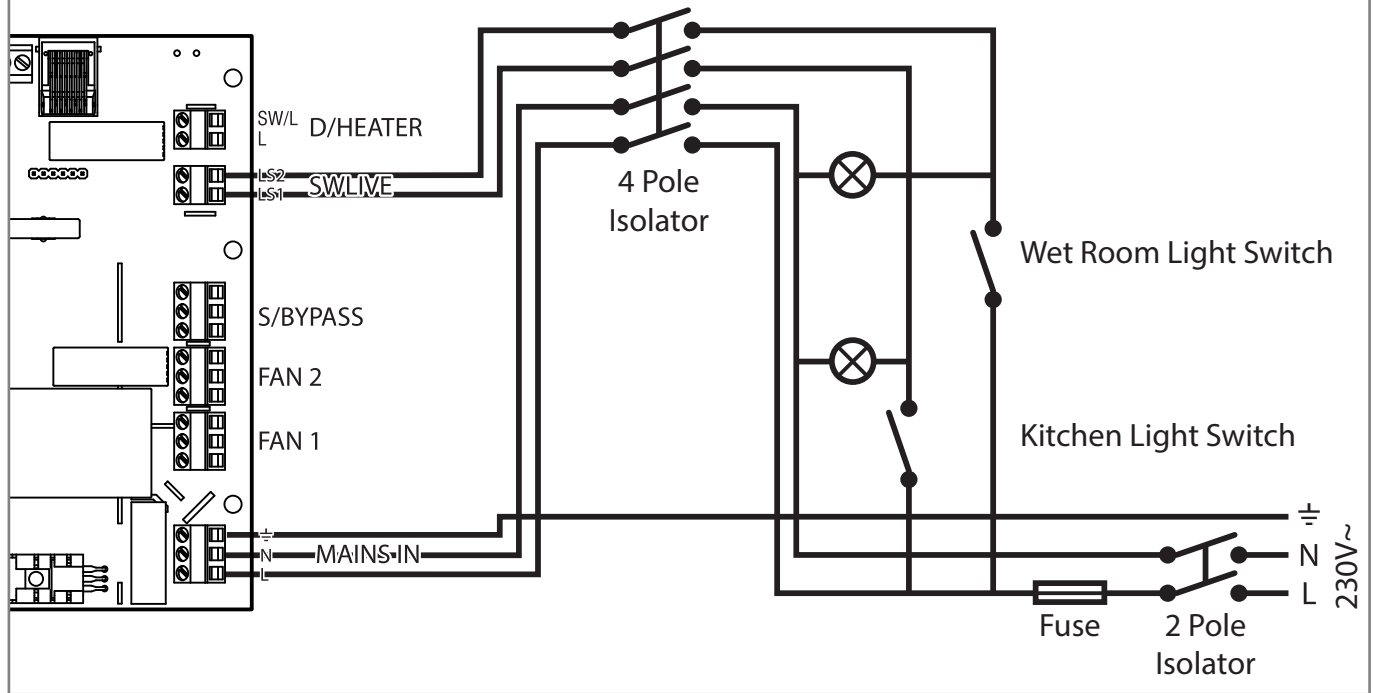

Supply wiring with switch inputs Ref EE166

TPxxxB/BE Units ONLY

Switch Defaults

- SW1 - Volt Free - Kitchen Boost.
- SW2 - Volt Free - Wet Room Boost.
- SW3 - Volt Free - SUMMERboost Control.

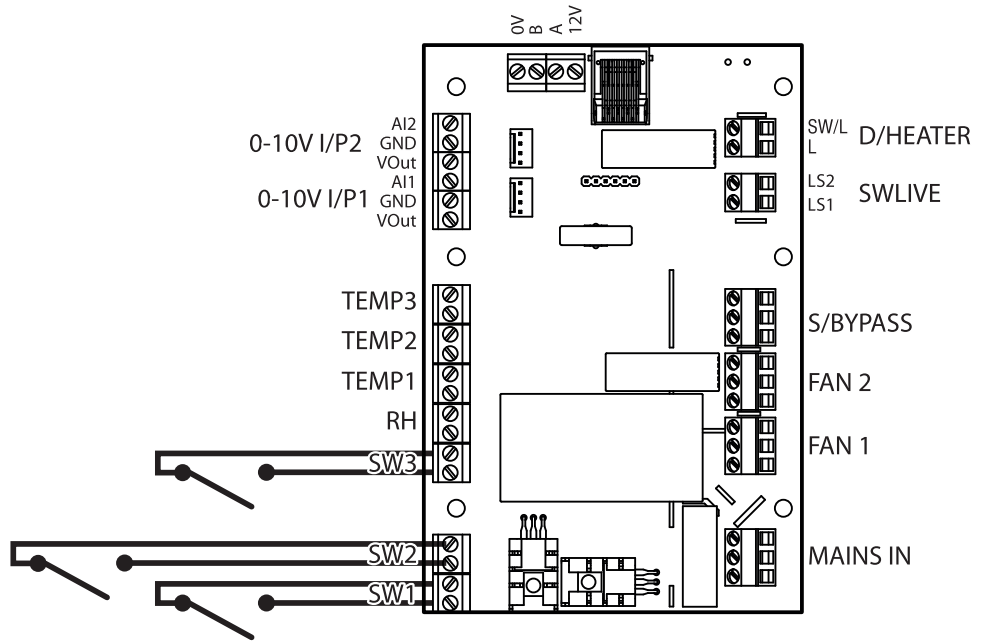

Volt Free switch inputs Ref EE163

Switch Defaults

- LS1 - 230V~ - Kitchen Boost
 - LS2 - 230V~ - Wet Room Boost
- The Switched Live (LS1, LS2) Boost(s) must be supplied via the same circuit as used to power the unit.

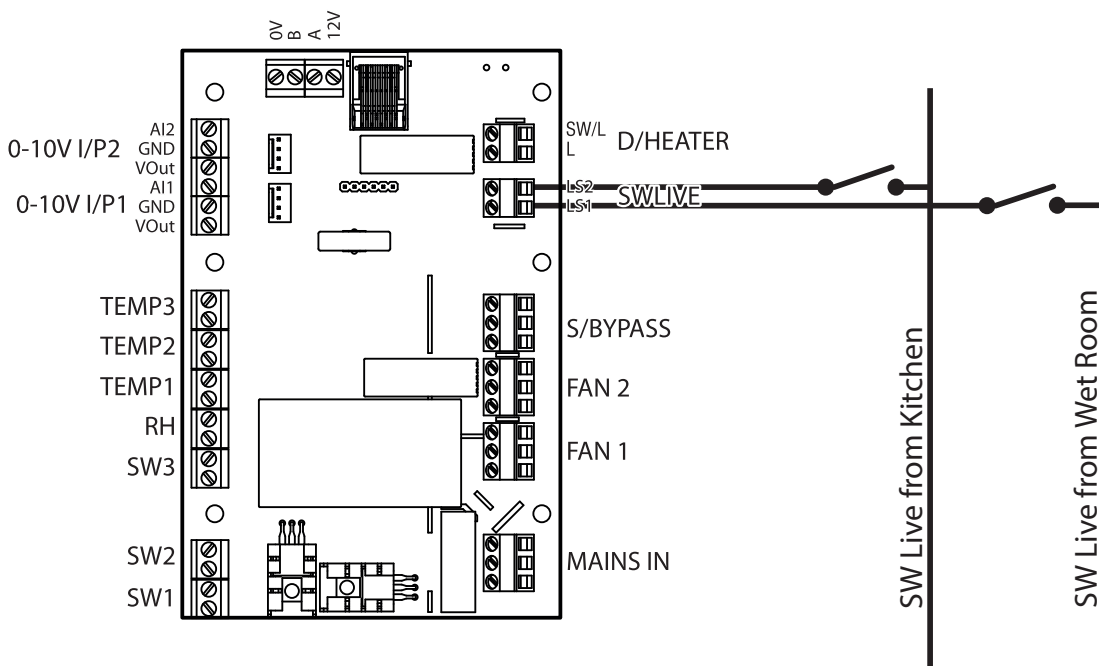

LIVE switch inputs Ref EE163

TPxxxB/BE Units ONLY

External Sensors

Any of these switch arrangements can be used in switch inputs SW1 to SW3 depending on their configuration and the type of MVHR.

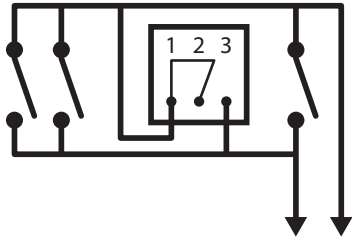

Volt-free boost switching of MVHR using single-pole switches TP502, TP503, TP507 and / or TP500/TP501 Humidistat.

There is a maximum of 10 single pole switches or Humidistats that can be used.



TP506 Latching Summer Mode switch / TP522 Latching SUMMERboost® switch.

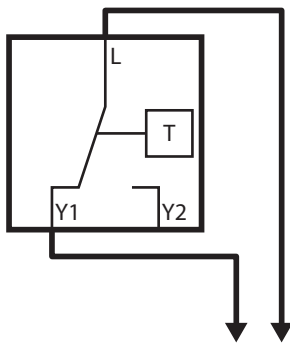

Volt-free control of SUMMERboost® using room thermostat. TP509 Room Thermostat

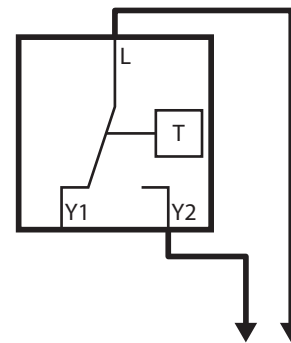

Volt-free activation of Summer Mode using room thermostat. TP509 Room Thermostat

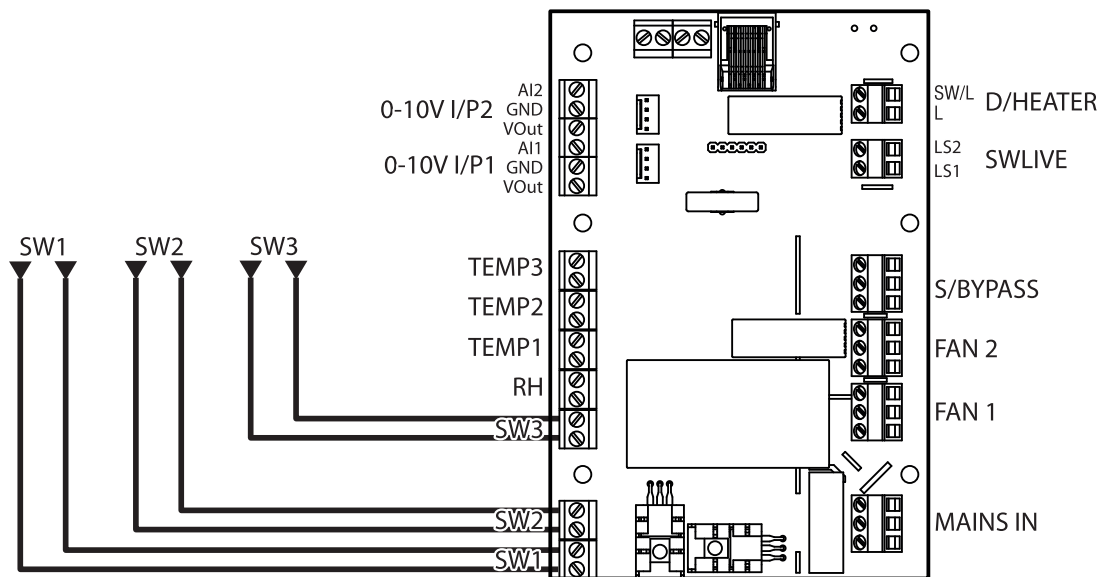

Connections Ref EE165

TPxxxB/BE Units ONLY

Switch Positions TP508 Three Position Rotary Switch

- 1 - Setback Speed
- 2 - Continuous Speed
- 3 - Boost Speed

For this configuration to function correctly;
 S1-1 Needs to be set to a Kitchen or Wet Room Boost switch,
 S1-2 Needs to be set to a Setback switch.

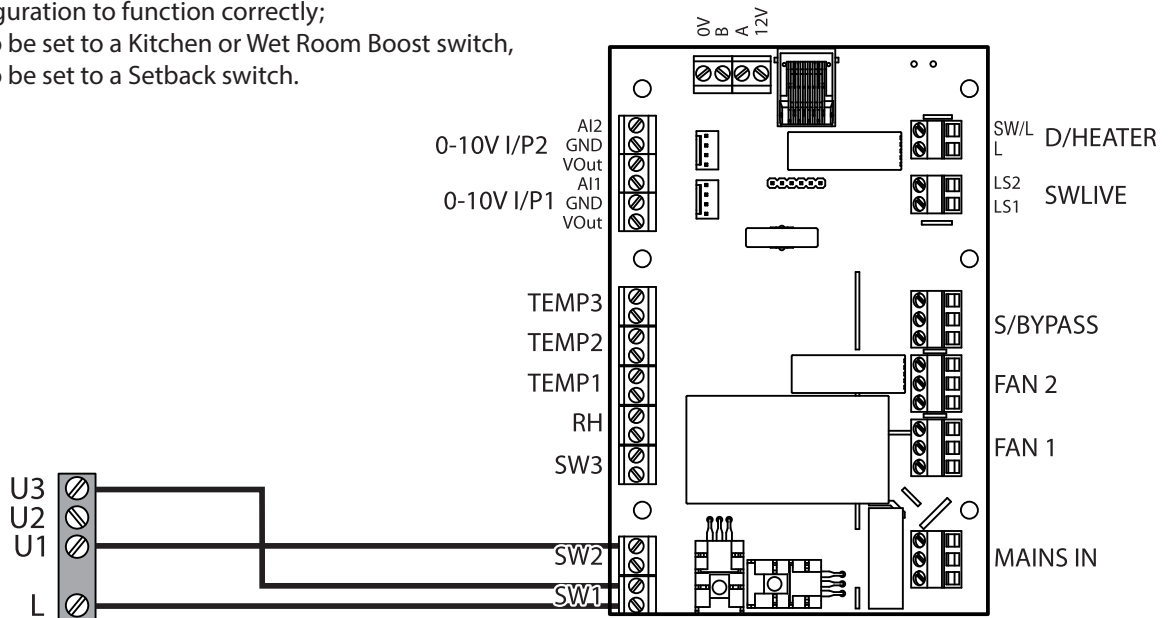

3-Way rotary switch Ref EE162

If sensors are fitted with switches ensure they are switched to VDC

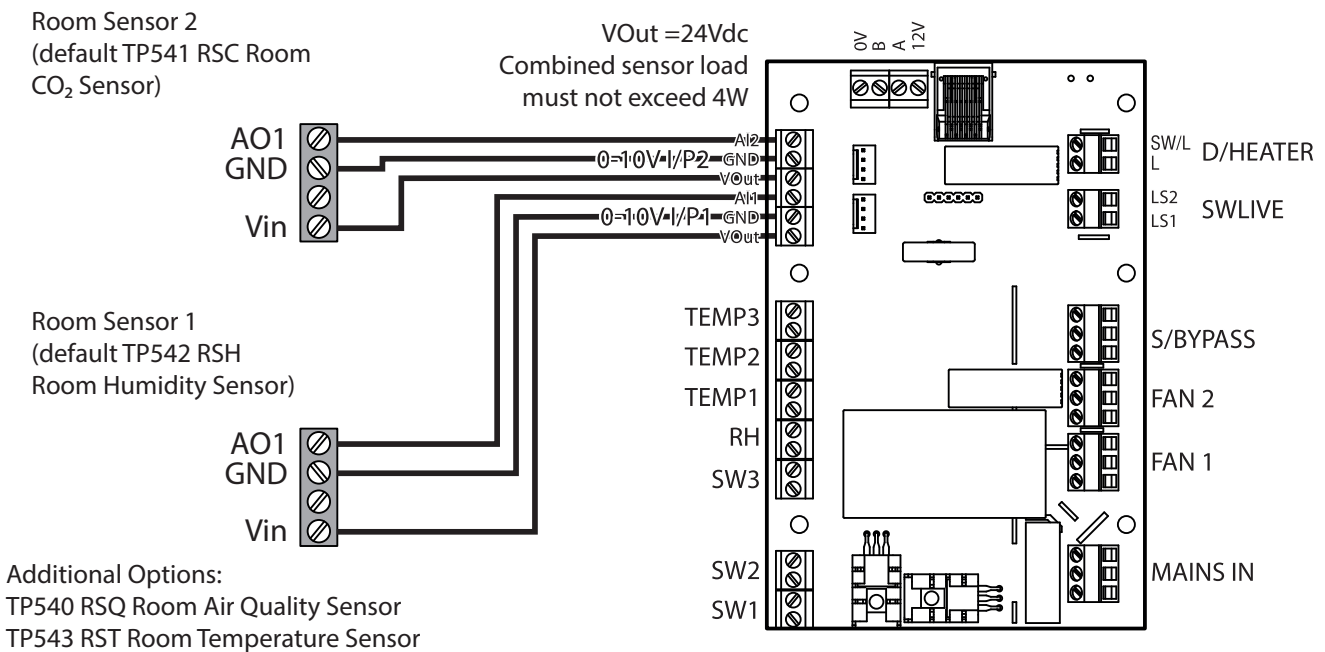

0-10V Sensor connections Ref EE161

Duct Heater

Using the factory fitted PCB TPxxxB models only it is possible to control an external mains operated duct heater to pre-warm the incoming fresh air supply. During periods of cold weather, this reduces the possibility of ice build-up within the unit by raising the temperature of the incoming supply air. However there will be a significant increase in electrical energy use.

Fitting

1. The heater is designed for insertion into standard spiral steel ducting and is fixed to the ducting with screws.
2. The air must flow through the heater in the direction of the arrow (located on the side of the heater close to the connection box).
3. The heater can be fitted in either horizontal or vertical ducting. The electrical connection cabinet can be freely placed facing upwards or sideways to a maximum angle of 90°. Fitting with the box facing downwards is NOT allowed.
4. The access opening in the heater must be equipped with a fixed mesh or an intake air device which makes it impossible to touch the element inside
5. A warning sign must be attached close to the air outlet, stating that the air outlet must not be covered.
6. The distance from (to) the heater to (from) a duct bend, valve, filter, etc should correspond to at least twice the duct diameter, otherwise there is a risk that the airflow through the heater is uneven which can cause activation of the overheating cut-out.
7. The heaters may be insulated in accordance with valid regulations for ventilation ducting. However, the insulation material must be incombustible. The cover of the heater must be free from insulation so that the type plate is visible and the cover can be removed.
8. The parts of the ventilation system where heaters are installed must be kept accessible to allow replacement and service.
9. The distance from the heater's metal casing to any wood or other combustible material must NOT be less than 30 mm.



Duct Heater

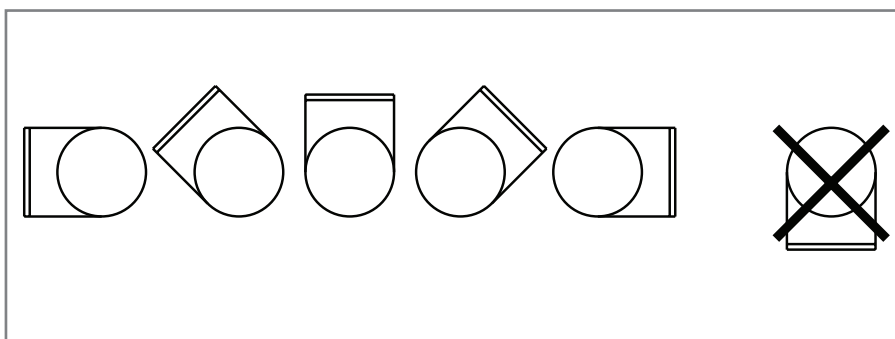

Duct Heater fitting orientation

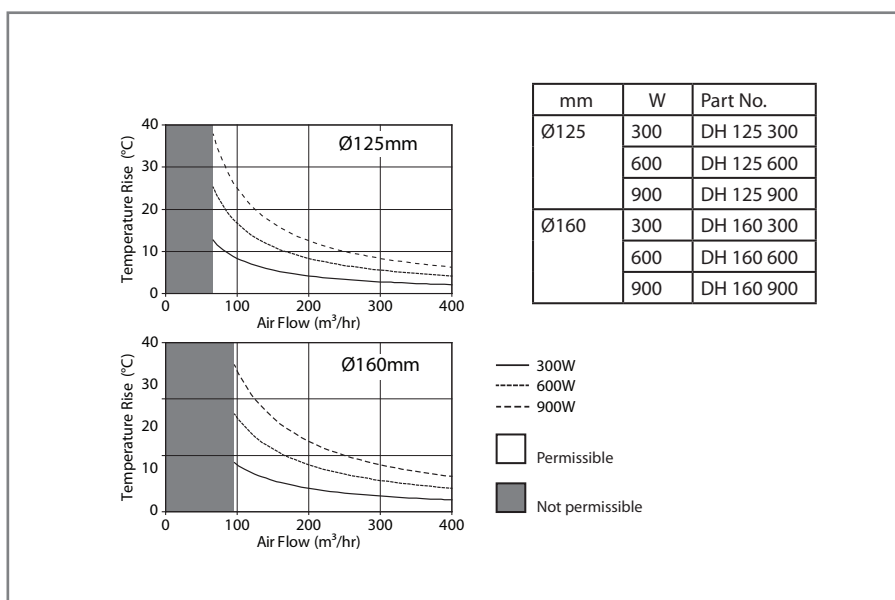

Duct Heater Operational Ranges

10. The maximum ambient temperature allowed is 40°C.
11. The air flow through the heater must have a speed of at least 1.5 m/s.
12. The maximum output temperature allowed is 40°C.

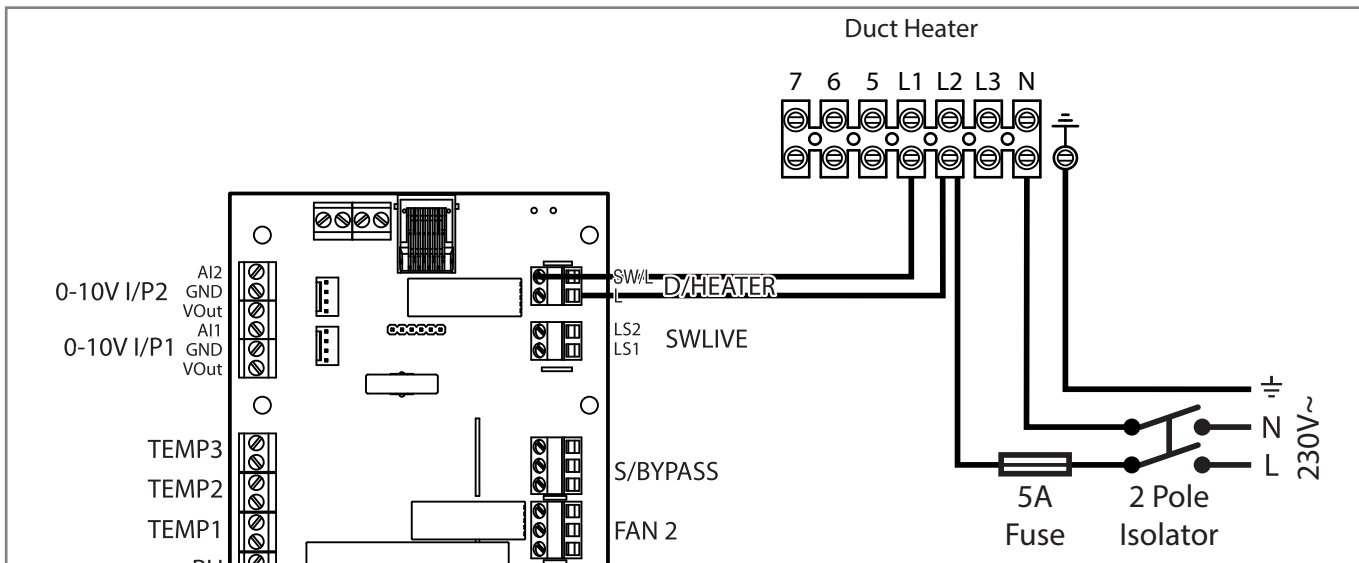

Duct Heater CV 12-09-1M Connection Wiring Diagram Ref EE165

Connection to Mains

1. All wiring must conform to current I.E.E. Wiring Regulations and all applicable national standards and Building Regulations.
2. The installation MUST be carried out by a suitably qualified competent person.
3. The duct heaters are designed to operate on single phase alternating current. See the wiring diagram for the particular heater and the electrical data on the rating plate placed on the cover of the duct heater.
4. The duct heater must be connected to the mains supply with a fixed installed round cable. The heater must be equipped with a cable grommet or cable fitting designed for the cable, which ensures that the electrical protection class of the heater is retained. The standard design is IP43.
5. It must not be possible to switch on the power to the element unless the *Q Plus* unit is operating. An all phase breaker or a double pole switch with a contact gap of at least 3mm must be included in the fixed installation.
6. The duct heater is equipped with two overheating cut-outs (one with manual reset) designed to prevent overheating when the airflow is too low or in the event of a fault in the system.
7. A drawing must be attached inside the fuse box or on the wall of the service room. The drawing shows the rating of the duct heaters and their location in the building, together with information about the measures to be taken in the event that the overheat protection cutout(s) is activated.

Maintenance

No maintenance is required except a periodic functional test.

Overheating

When the overheating cut-out with manual reset has been activated, the following should be observed:

1. The heater must not be interfered with in any way, such as removal of the cover, except by an authorised electrical fitter.
2. Turn off the mains power.
3. Investigate carefully the reason for activation of the cut-out.
4. When the fault has been eliminated, the cut-out can be reset.

The heater has a built in manual reset thermal protection with the reset button placed on the lid of the duct heater.

Commissioning Units TPxxxB/BE

HRV Controller Options

Once installation of the ducting, HRV and Controller is complete the ventilation system will need to be commissioned and setup. See the relevant HRV Controller Product Manual for how to change fan speeds and all adjustable settings.

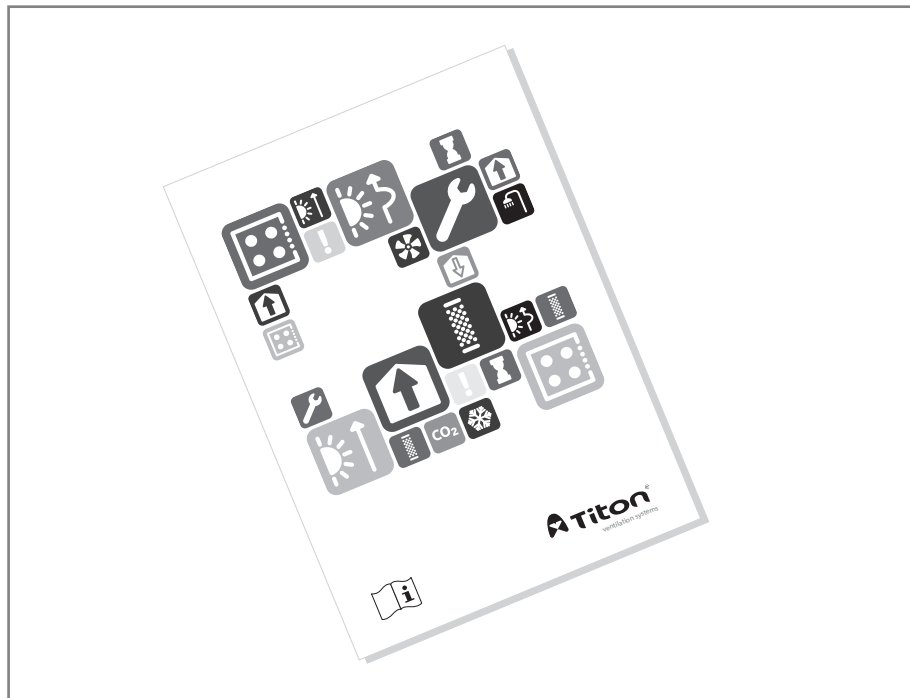

aurastat® HRV Controller Product Manual

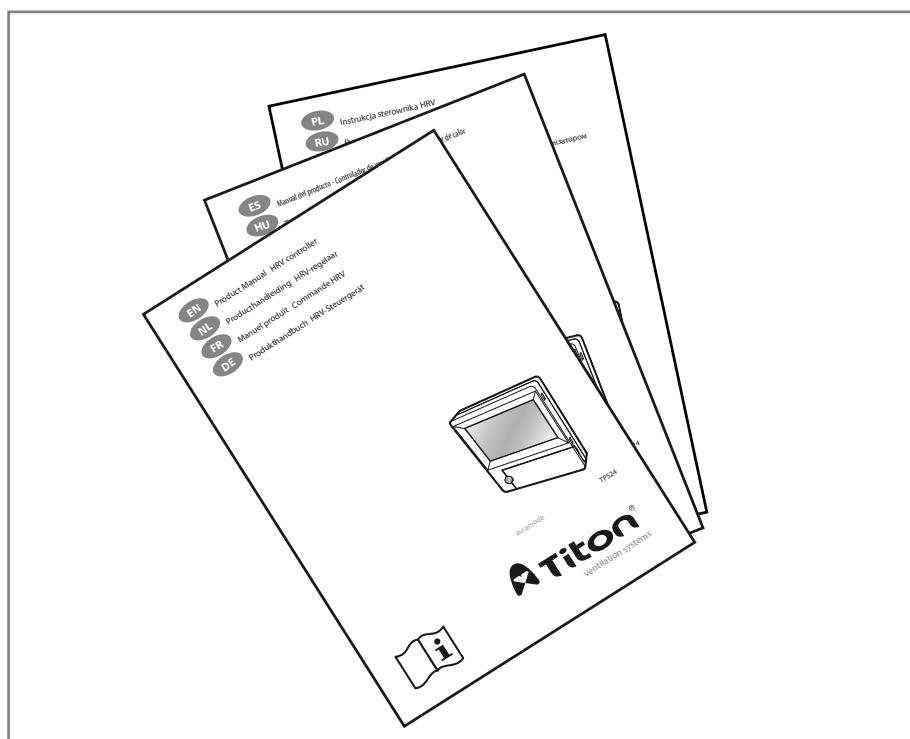

auramode® HRV Controller Product Manuals



Maintenance

Routine Maintenance

All ventilation units require periodic maintenance. Routine maintenance, apart from filter changes, must only be carried out by a suitably qualified and competent person.

WARNING: The unit uses a 230V ~ supply and contains rotating mechanical parts. ISOLATE the unit from mains power supply and allow sufficient time for all moving parts to stop before undergoing any Servicing or Maintenance. The unit may be supplied with multiple live supply if a Duct Heater is fitted or uses switched live for Boost Speed control.

Front Cover Removal

1. ISOLATE the unit from mains power supply and allow sufficient time for all moving parts to stop
2. Loosen the two corner screws located on the bottom front of the unit
3. Completely remove the centre screw
4. Completely remove the Front Cover by pulling it away from the unit at the bottom and lifting

Cover replacement is the reverse of the above steps. Ensure it is securely located at the top before tightening screws.

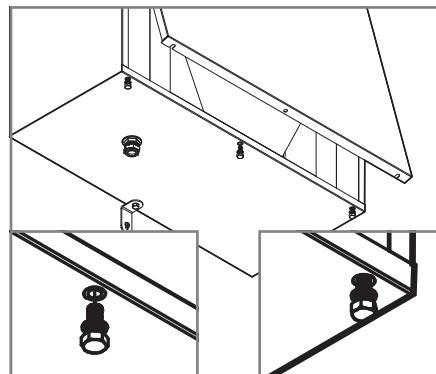

Cleaning Interior

For best results:

1. Slide out Filter Frames fitted either side of heat exchanger
2. Carefully remove any dust from face of heat exchanger, interior of the unit and the Bypass(if fitted) using a vacuum cleaner

Do not use water or any other fluids

Cleaning Exterior

For best results use a clean damp cloth. Do not use abrasive cleaners, solvents or any other fluids.

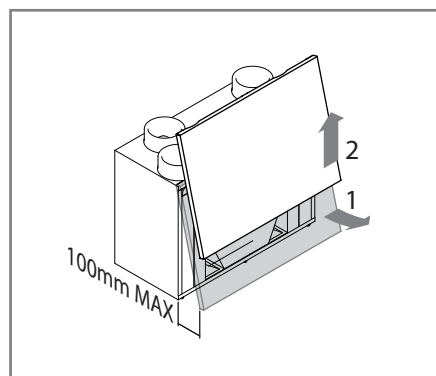

Condensate Tray

If the Condensate Tray is split a replacement must be ordered and fitted.

HRV1, 1.25 & 1.35 Q Plus Part No. XP40042/012

HRV 1.75, 2, 2.85 & 3 Q Plus Part No. XP40142/012

Filter Replacement

Filters should be replaced at least annually, or more regularly dependent on environmental conditions. The aurastat® will indicate filter change required in line with the Filter Change Interval setting. Replacement Filters are available from Titon Direct. www.titondirect.co.uk

Titon HRV *Q Plus* Filters are available in two grades G3 and G4. Filter media should be replaced like for like.

Filter Part numbers in table below. The Unit part number can be found on the serial number label fixed to the top and front of the unit.

G3 Filters - Both faces white.

G4 Filters - One face white, one face blue.

Model	Part Number	G3 Filter Set 2 framed filters	G4 Filters Set 2 framed filters
HRV1.25 <i>Q Plus</i>	TP406HMB TP416B	XP40032/099	XP46022/099
HRV1.35 <i>Q Plus</i>	TP408HMB TP408HMBE TP418B TP418BE		
HRV1.75 <i>Q Plus</i>	TP404HMB TP414B	XP40133/099	XP46133/099
HRV2 <i>Q Plus</i>	TP401HMB TP401HMBE TP411B TP411BE		
HRV2.85 <i>Q Plus</i>	TP407HMB TP417B		
HRV3 <i>Q Plus</i>	TP402HMB TP402HMBE TP412B TP412BE		

How to Change Filters

1. Remove Front Cover or Filter Covers.
2. Slide out Filters.
3. HRV 1.75, 2, 2.85 & 3 *Q Plus* models use unequal Filters. Make a note of which side of the unit the filter with the shorter filter media is. The positions of filters is marked on the units.



Shorter Media Filter

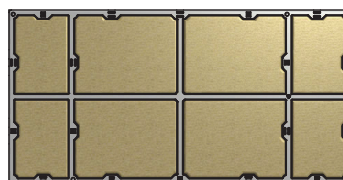

4. Replace Filters by carefully sliding in the replacement filters. Ensure that filters are replaced in the same positions as they were removed. The positions of filters is mark on the units.
5. Replace the Front Cover or Filter Covers.

In the event of any queries please contact the system installer.

Ensure this booklet is passed to the householder once installation & commissioning of the ventilation system is complete. This Product Manual must be kept in the Home Information Pack and used as a service record.

Installed by:



MARKETING DIVISION
894 The Crescent, Colchester Business Park, Colchester, CO4 9YQ
Tel: +44 (0) 1206 713800 Fax: +44 (0) 1206 543126
Email: ventsales@titon.co.uk Web: www.titon.com