



FoilBoard Suspended Installation Guide

TI 5005

FoilBoard for Suspended Floor Constructions

INTRODUCTION

Our FoilBoard suspended system provides assured performance in timber suspended floors. The nature of the foilboard panel to transfer heat efficiently increases performance by over 30% compared to systems that do not use heat diffusers.

The FoilBoard panels are laid between joists supported by brackets. This ensures that the system is in direct contact with the floor deck, maximising the transfer of heat from pipe to the deck. The panels are manufactured from XPS insulation. The panels have a pre-bonded soft temper aluminium diffuser making the panels easy to trim and adjust on site. Once the brackets are installed the panels drop into place in exactly the right position. Alternatively, battens can be used to support panels.

The standard product is available in 50mm and for joists at 400mm centres however other products are available.

INSTALLATION

1. Fix supporting brackets (or battens) to the side of the joist, ensuring that when the foilboard panels are installed there is no air gap between the panel and the floor.
2. Within each joist space lay a FoilBoard loop panel at each end of the run.
3. Lay FoilBoard straight panels between the loop ends, trimming where necessary.
4. Notch the joist wherever the pipe will cross, conforming to current regulations.
5. Starting at the manifold, lay the pipe into the FoilBoard according to the design.
6. Pressure test prior to laying floor deck and finish. Keep under pressure.

Note : Please refer to installation guides for full installation details

SPECIFICATION

Timoleon FoilBoard Suspended system comprising of 50mm XPS Insulation with pre-bonded heat diffusers to be installed between joists at 400mm centres. 16mm PE-RT pipe to be inserted into the pre-routed grooves. Floor Deck to be laid and fixed over. The system to be designed, installed and commissioned to BS1264.

TECHNICAL INFORMATION

Pipe – 16mm PE-RT pipe with EVOH oxygen barrier.

Foilboard Suspended Panel – XPS insulation with pre-bonded soft temper aluminium (k=0.033W/mK).

Heat outputs are dependent on the water temperature, floor construction, system dimensioning, floor finish & design conditions. Please call 01392 363605 for advice.

Heat Output Table (W/m ²)		Flow & return water temperature (°C)		
		50/40	45/35	40/30
Floor Finish	Tile Finish (0.01m ² K/W)	118	94	69
	15mm Wood Finish (0.1m ² K/W)	83	66	48
	Carpet & Underlay (0.15 m ² K/W)	70	55	41

Based on 16mm PE-RT pipe at 200mm centres using standard product (**high performance configurations available**) with 18mm chipboard laid over (plus 10mm ply for tiles). 0.15 m²K/W = 1.5 TOG. Air Temperature = 20°C

FoilBoard Installation guide TI5005 - Suspended

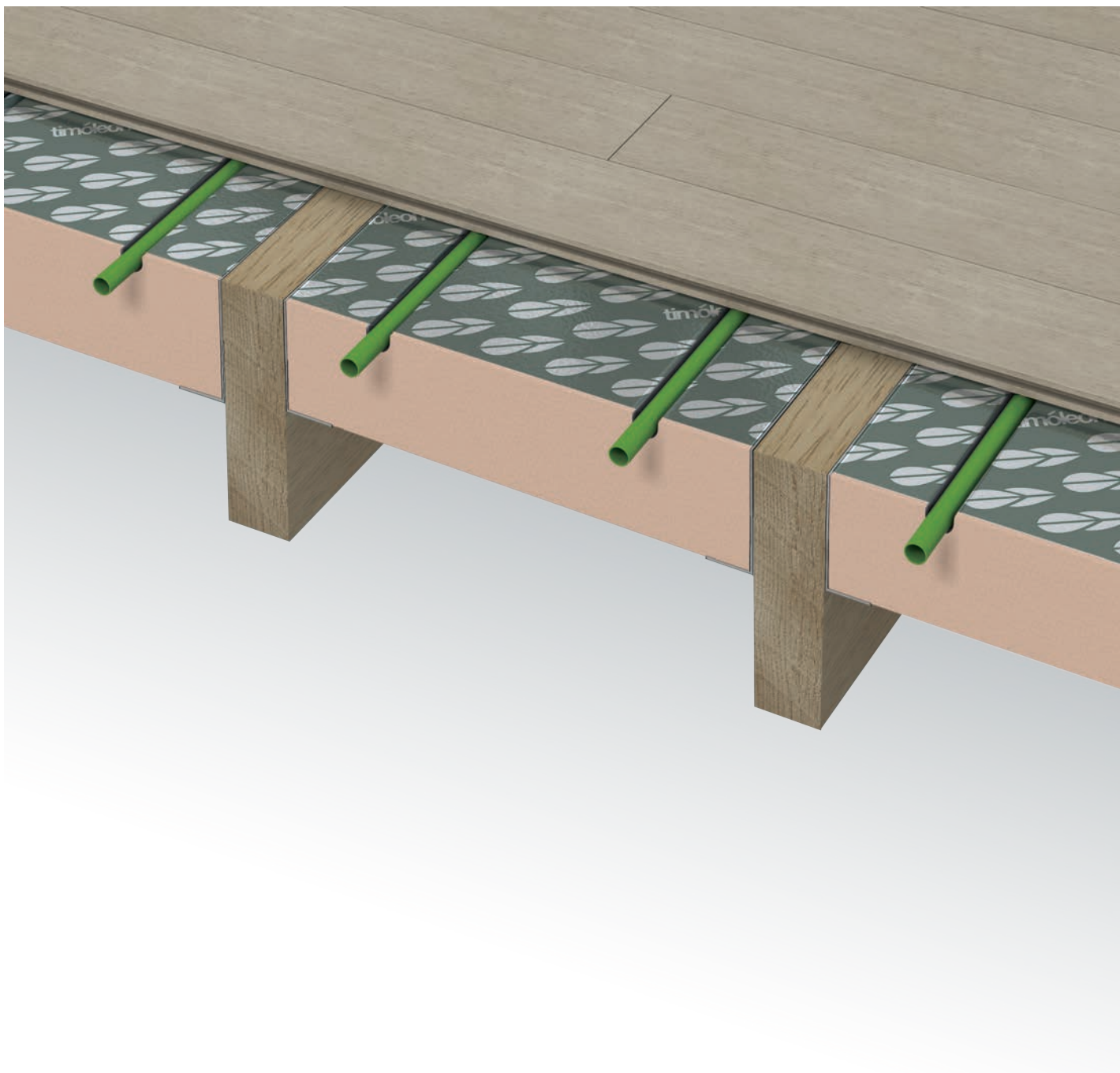

The FoilBoard panels are laid between joists supported by brackets, ensuring that the system is in direct contact with the floor deck, maximising the transfer of heat from pipe to the deck. The panels are manufactured from XPS insulation with pre-bonded soft temper aluminium, making the panel easy to trim on site. Once the brackets are installed the panels drop into place in exactly the right position.

The standard product is available in thicknesses from 50mm and for joists at 400mm centres however other products are available.



PRIOR TO INSTALLATION

If it is necessary to store the system once you have taken delivery ensure it is kept dry, out of direct sunlight and away from sharp objects or possible chemical spillage. Ensure the area is weather tight.

1

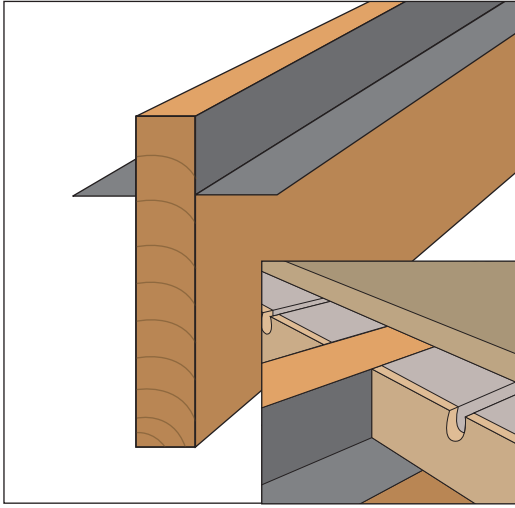

Fix the “L” shaped supporting brackets to the sides of the joists with the top of the bracket flush with the top of the joist. This ensures the FoilBoard panels are in tight contact with the underside of the floor deck when installed. (As shown inset)

Alternatively use wooden battens (typically 35x35) fixed onto the joist.

IMPORTANT - the space left only for the foilboard panel must be 1mm to 2mm less than the panel thickness.

2

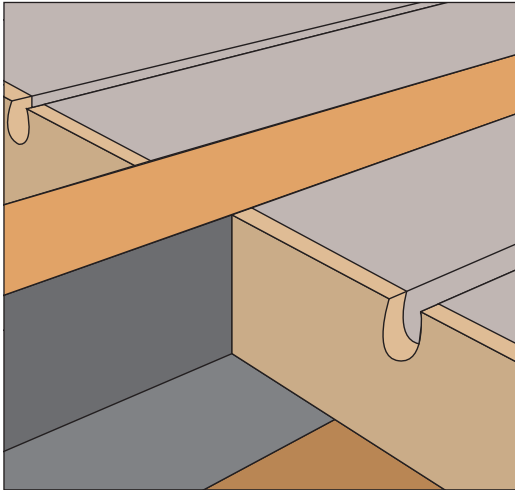

Each straight panel has a loop at one end. Within each joist space lay a FoilBoard panel with a loop panel at the each end of the run as detailed on the supplied CAD drawing.

3

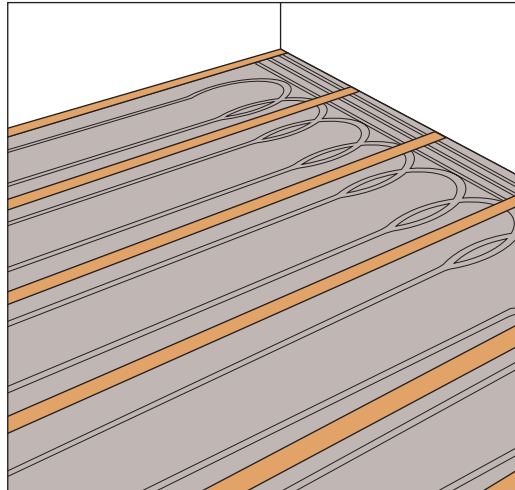

Lay FoilBoard panels between the loop ends, trimming where necessary and using the off-cut within the next joist space.

4

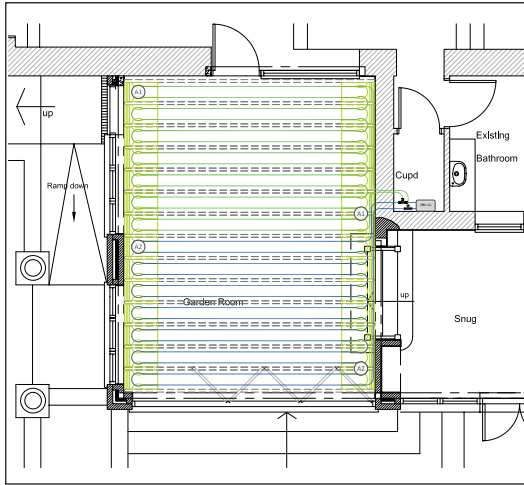

Install the pipe. Start at the manifold and follow the CAD drawing. Notching and drilling in solid wood joists must be done in accordance with Building Regulations Part A such that:

- a) Holes should be drilled through the neutral axis and should be positioned between 0.25 and 0.4 times the joist span length.
- b) Must not be less than 3 diameters (of the hole) apart.
- c) Notches must not be greater than 0.25 times the joist depth.

Flows and returns can be bunched together, insulated and run through the joists at the appropriate place or run individually through the tops of the joist following building regulations Part A.

5

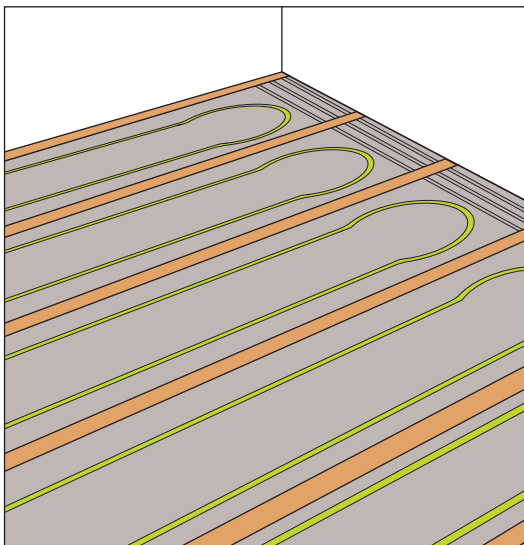

Repeat until all circuits are laid.

6

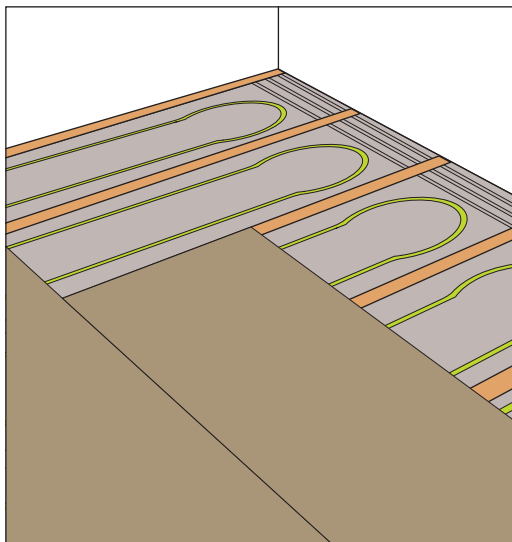

Pressure Test and keep under pressure whilst the floor deck and floor finish are being laid.



WARNING

If the pipe work is kinked during the installation, the coil must be replaced or the pipe repaired with a Timóleon connector and then pressure tested. No connections should be made unless accessible.

Filling/pressure testing

1. If the manifold is being used to pressure test all circuits close both primary isolation valves.
2. Connect a pressure tester to any drain valve and increase the pressure to 6 bar.
3. Once at this pressure, leave for 60 minutes. If the pressure has dropped examine the pipework. It may be necessary to pressure test individual circuits to determine if there has been damage to the pipe.
4. If the pressure is maintained and passes the test record the results on the pressure test certificate. Have the test witnessed and certified by a third party.
5. Maintain this test pressure whilst the floor deck is being laid.

Wood Floors

When hardwood floors are laid, the moisture-content of the timber should be 8-10%. Please check with the flooring supplier that the proposed floor is suitable with underfloor heating.

During the initial heat up, the mixing valve should be set to supply temperature between 20°C and 25°C which needs to be maintained for at least 3 days. After this period, the flow temperature can then be increased to the design maximum and should be held for a further 4 days to complete the process.

Accessories for this system

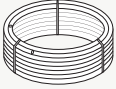
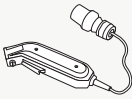
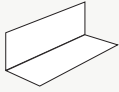
	16mm Underfloor heating pipe
Code	UPI-16XXX
Dimensions	16mm
	110V Hot blade cutter
Code	UAC-HBCUT
Dimensions	-
	L Brackets
Code	-
Dimensions	-

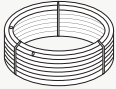
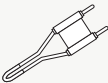
	12mm Underfloor heating pipe
Code	UPI-12XXX
Dimensions	12mm
	Blade 16mm
Code	UAC-HBL16
Dimensions	16mm

Polyethylene RT (PE-RT) Plastic pipe for underfloor heating

INTRODUCTION

Timoleon uses high quality PE-RT underfloor heating pipes from HakaGerodur AG. The five-layer structure achieves a high degree of oxygen tightness and ensures that this is retained even under rough building site conditions.

The entire HakaGerodur range is backed by decades of experience in plastics processing.



STRUCTURE/ MATERIAL

PE-RT heating pipes use a specially modified polyethylene of medium density, the molecular structure and composition of which ensures very good thermal stability and a high degree of mechanical strength.

The five-layer pipe structure is manufactured by means of extrusion in one single process. The EVOH layer provides a very good oxygen barrier while the outer PE-RT layer protects the pipe from damage.

DIMENSIONS & APPLICATIONS

- ↘ 12mm, 16mm, 20mm
- ↘ Not potable
- ↘ Not for high temperature systems
- ↘ Underfloor heating
- ↘ Ceiling cooling

APPROVALS & STANDARDS

- ↘ KOMO approval: K14254
- ↘ SKZ (Southern German Plastics Centre) monitored (SKZ symbol A236)
- ↘ Properties in accordance with DIN 16833 / 16834

ADVANTAGES

- ↘ Oxygen-tight with co-extruded EVOH layer in accordance with DIN 4726.
- ↘ Operational range max. 6 bar, max constant temperature 60 °C.
- ↘ Pipes made of PE-RT are corrosion free.
- ↘ Excellent stress crack resistance.
- ↘ Flexible and easy to lay.
- ↘ Tight bending radius.
- ↘ Resistant to numerous chemicals (details on request).
- ↘ No incrustation due to smooth inner pipe surface.
- ↘ Low weight.

