



FoilBoard Floating Installation Guide

TI 5004

FoilBoard system for Floating Floor Constructions

INTRODUCTION

Our FoilBoard Floating system is laid over a solid floor. The panels provide the support for the fully floating floor deck that is laid over. Each panel is manufactured from extruded polystyrene insulation which has a high compressive strength, suitable for floating floor applications.

The heat diffusers are pre-bonded and made from soft temper aluminium. As no thick rigid plates are used the panels are easily trimmed on site.

Once the insulation is laid a tongue and groove floor deck is laid over. The product is available in standard thicknesses from 25mm to 75mm, however other thicknesses are available to suit your project as required.

INSTALLATION

1. Lay the FoilBoard loop panels at each end of the room over a level floor according to the design.
2. Lay FoilBoard straight panels between the loop ends.
3. Use plain insulation of the same thickness and grade to complete the floor where necessary.
4. Starting at the manifold, push the pipe into the FoilBoard grooves according to the design.
5. Pressure test each circuit prior to laying floor deck and finish.
6. Lay a fully floating tongue and groove floor deck over. Keep under pressure.

Note : Please refer to installation guides for full installation details

SPECIFICATION

Timoleon FoilBoard Floating system using 16mm PE-RT pipe installed into 50mm FoilBoard panels comprising of XPS extruded polystyrene with pre-bonded heat diffusers to be installed as a continuous insulation layer to support a fully floating floor. Tongue and groove floor deck to be laid over. The system to be designed, installed and commissioned to BS1264.

TECHNICAL INFORMATION

Pipe – 16mm PE-RT pipe with EVOH oxygen barrier.

FoilBoard Floating Panels – XPS extruded polystyrene panel with pre-bonded soft temper aluminium ($k=0.033W/mK$). Panel dimensions 1200mm x 600mm x 50mm (other thicknesses are available).

Heat outputs are dependent on the water temperature, floor construction, system dimensioning, floor finish & design conditions. Please call 01392 363605 for advice.

Heat Output Table (W/m ²)		Flow & return water temperature (°C)		
		50/40	45/35	40/30
Floor Finish	Tile Finish (0.01m ² K/W)	66	53	39
	15mm Wood Finish (0.1m ² K/W)	53	42	31
	Carpet & Underlay (0.15 m ² K/W)	47	38	28

Based on 16mm PE-RT pipe at 150mm centres using standard product with 18mm chipboard laid over.
0.15 m²K/W = 1.5 TOG.

FoilBoard Floating Installation guide TI5004

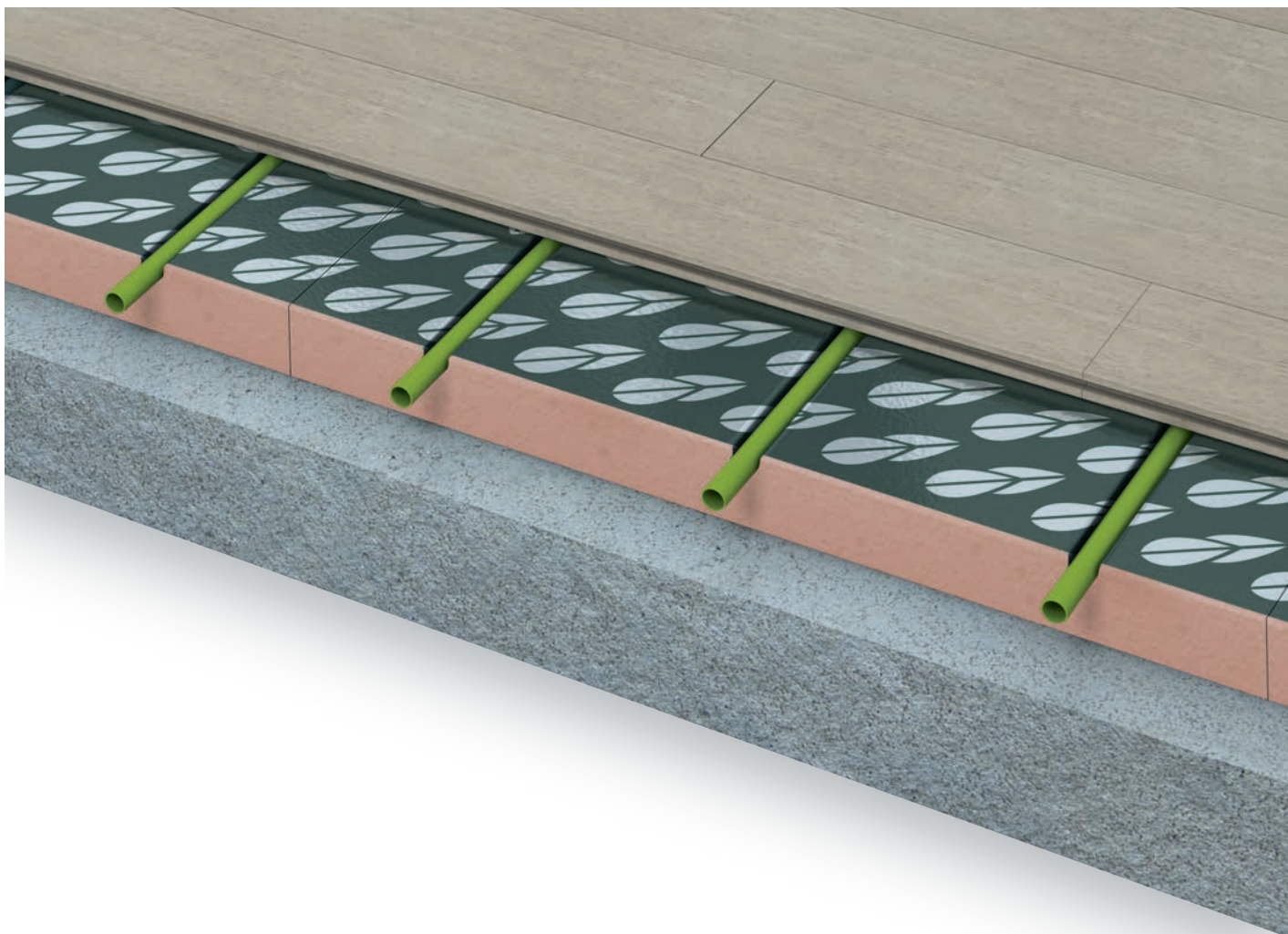

Our FoilBoard Floating system is laid over a solid floor. The panels provide the support for the fully floating floor deck that is laid over. Each panel is manufactured from XPS insulation which has a high compressive strength, suitable for floating floor applications.

The heat diffusers are pre-bonded and made from soft temper aluminium. As no thick rigid plates are used the panels are easily trimmed on site.

Once the insulation is laid a tongue and groove floor deck is laid over. The product is available in standard thicknesses from 25mm to 75mm, however other thicknesses are available to suit your project as required.



PRIOR TO INSTALLATION

If it is necessary to store the system once you have taken delivery ensure it is kept dry, out of direct sunlight and away from sharp objects or possible chemical spillage. Ensure the area is weather tight.

1

Ensure existing slab/floor deck meets at least SR2 (5mm deviation in 2m) requirements for floor regularity (BS8204) and preferably SR1 (3mm deviation in 2m). Note the floor batten or floor finish company may have their own requirements which take precedent.

2

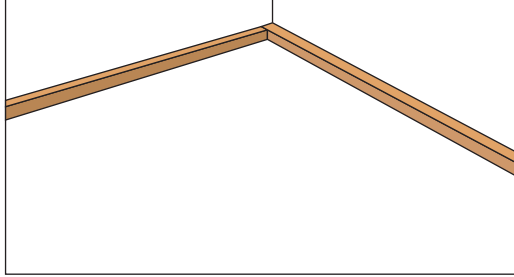

Lay a supporting batten around the perimeter of the room (the same thickness as the insulation being used).

3

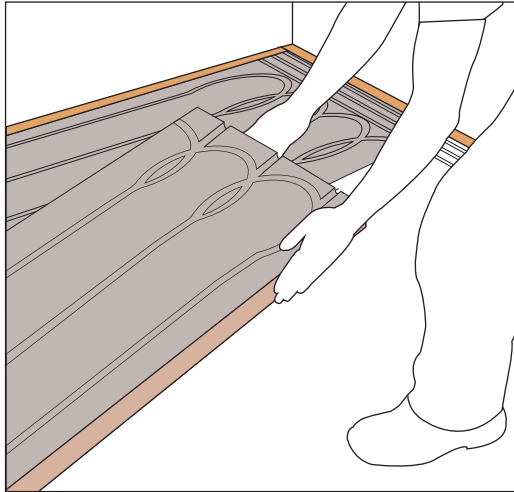

Starting at the corner, lay the foilboard panels trimming where necessary. Using the off-cut to start the next set of straight panels.

4

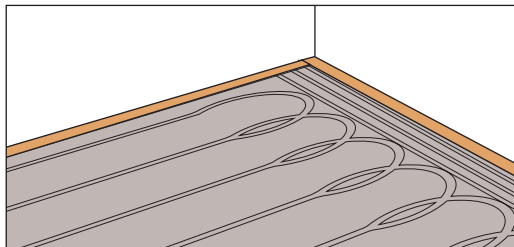

Use plain insulation of the same thickness and grade to complete the insulation layer where necessary.

5

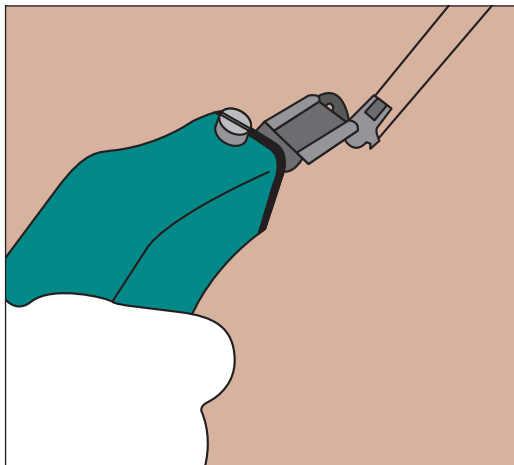

Use a hot blade cutter to create channels for flows and returns where required especially approaching the manifold (available from Timóleon).

Filling/pressure testing

1. If the manifold is being used to pressure test all circuits at once close both primary isolation valves.
2. Connect a pressure tester to any drain valve, vent the system of air and increase the pressure to 6 bar.
3. Once at this pressure, leave for 60 minutes. If the pressure has dropped examine the pipework. It may be necessary to pressure test individual circuits to determine if there has been damage to the pipe.
4. If the pressure is maintained and passes the test record the results on the pressure test certificate. Have the test witnessed and certified by a third party.
5. Maintain this test pressure whilst the screed is being laid.

Floating floors

The floor deck should be timber or timber composite with tongued and grooved edges.

Foilboard panels and plain insulation should butt tightly together with no gaps. Battens should be installed around room perimeters to support the floor deck and at access traps and in door thresholds. Insulation sheets should be laid so that joints are not co-incident with joints in the floor deck above.

Always refer to the flooring manufacturers' instructions.

During the initial heat up, the mixing valve should be set to supply temperature between 20°C and 25°C which needs to be maintained for at least 3 days. After this period, the flow temperature can then be increased to the design maximum and should be held for a further 4 days to complete the process.

Accessories for this system (dependent on room)

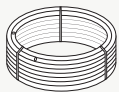
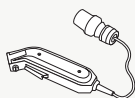
	25mm FoilBoard Floating
Code	UFU-025FL
Dimensions	1200 x 600 x 25
	16mm Underfloor heating pipe
Code	UPI-16XXX
Dimensions	16mm
	110V Hot blade cutter
Code	UAC-HBCUT
Dimensions	-

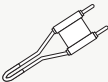
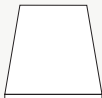
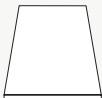
	Blade 16mm
Code	UAC-HBL16
Dimensions	16mm
	Plain Insulation
Code	UINXXXPP
Dimensions	1200x600mm
	SRB
Code	-
Dimensions	1200x600mm

*Other foilboard sizes are available.

Polyethylene RT (PE-RT)

Plastic pipe for underfloor heating

INTRODUCTION

Timoleon uses high quality PE-RT underfloor heating pipes from HakaGerodur AG. The five-layer structure achieves a high degree of oxygen tightness and ensures that this is retained even under rough building site conditions.

The entire HakaGerodur range is backed by decades of experience in plastics processing.



STRUCTURE/ MATERIAL

PE-RT heating pipes use a specially modified polyethylene of medium density, the molecular structure and composition of which ensures very good thermal stability and a high degree of mechanical strength.

The five-layer pipe structure is manufactured by means of extrusion in one single process. The EVOH layer provides a very good oxygen barrier while the outer PE-RT layer protects the pipe from damage.

DIMENSIONS & APPLICATIONS

- ↘ 12mm, 16mm, 20mm
- ↘ Not potable
- ↘ Not for high temperature systems
- ↘ Underfloor heating
- ↘ Ceiling cooling

APPROVALS & STANDARDS

- ↘ KOMO approval: K14254
- ↘ SKZ (Southern German Plastics Centre) monitored (SKZ symbol A236)
- ↘ Properties in accordance with DIN 16833 / 16834

ADVANTAGES

- ↘ Oxygen-tight with co-extruded EVOH layer in accordance with DIN 4726.
- ↘ Operational range max. 6 bar, max constant temperature 60 °C.
- ↘ Pipes made of PE-RT are corrosion free.
- ↘ Excellent stress crack resistance.
- ↘ Flexible and easy to lay.
- ↘ Tight bending radius.
- ↘ Resistant to numerous chemicals (details on request).
- ↘ No incrustation due to smooth inner pipe surface.
- ↘ Low weight.

