

The image features a dark blue background on the left side, which transitions into a white background on the right. A series of thin, yellow, curved lines flow from the top left towards the bottom right, creating a sense of movement and depth. The 'bre' logo is positioned in the upper left quadrant of the blue area.

bre

**Thermohouse – Thermal
Assessment of 300
Standard Element and
Roof Element**

Prepared for:

Jack O'Driscoll
Managing Director
Thermohouse
MCG Group Ltd

22nd September 2009

BRE report number 255996

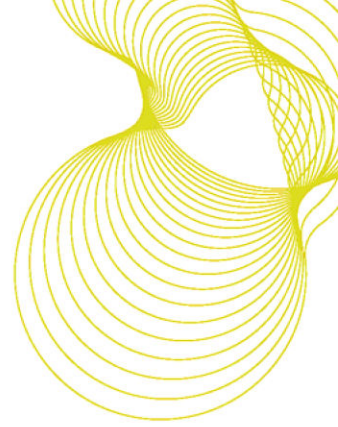

Prepared by

Name Sean Doran

Position Senior Consultant

Signature 

Approved on behalf of BRE

Name Brian Anderson

Position Technical Director

Date 22 September 2009

Signature 

BRE Scotland
Orion House
Bramah Avenue
East Kilbride
Glasgow, G75 0RD
T + 44 (0) 1355 576200
F + 44 (0) 1355 576210
E eastkilbride@bre.co.uk
www.bre.co.uk



This report is made on behalf of BRE. By receiving the report and acting on it, the client - or any third party relying on it - accepts that no individual is personally liable in contract, tort or breach of statutory duty (including negligence).

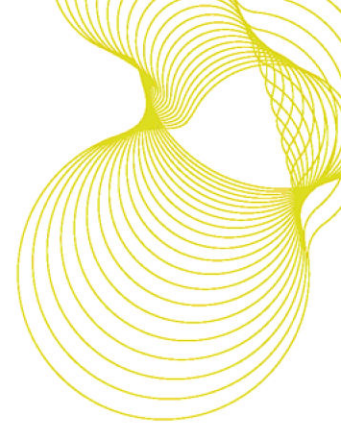

Executive Summary

BRE has been commissioned by Thermohouse of MGC Group Ltd. to undertake a three-dimensional thermal performance assessment of an ICF wall construction (Thermohouse 300). Two variations of the Thermohouse 300 ICF detail are modelled, with the thermal conductivity of the EPS at 0.035 W/m•K (higher conductivity) and 0.030 W/m•K (lower conductivity). Additionally, BRE has been asked to carry out calculations for a roof panel design.

Calculations have been carried out using the relevant standards BR497^[5] and EN ISO 10211^[1,2] and the following points are concluded:-

- The minimum surface temperatures for the ICF wall comply with the requirements in the BRE Information Paper IP 1/06^[4]. The higher conductivity model produced a minimum surface temperature factor (f_{Rsi}) of 0.967, the lower conductivity model produced a factor of 0.974.
- The U-value of the higher conductivity ICF model was found to be 0.23 W/m²K. As expected, the lower conductivity model produced an improved U-value of 0.20 W/m²K.
- The U-value was also calculated for the lower conductivity ICF model, but without taking into account the impact of the steel fixings. This resulted in a U-value of 0.18 W/m²K, meaning the steel fixings cause an increase to the U-value of 0.016 W/m²K.
- The U-value for the roof panel was found to be 0.15 W/m²K and its minimum surface temperature factor was found to be 0.98.

Details of the calculations are given in Appendix A of the report.

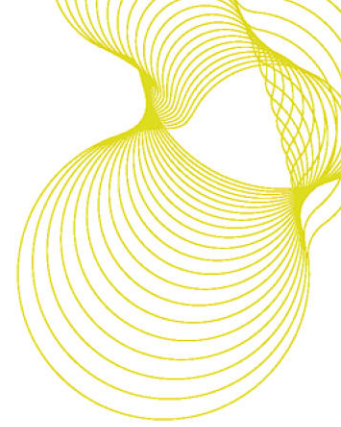

Contents

Introduction	1
The wall and roof constructions	2
The ICF wall construction	2
The roof panel construction	2
Results	3
The ICF wall	3
The roof panel	3
References	4
Appendix A: Technical Information regarding the ICF wall	5
Appendix B Technical information regarding the roof panel	12

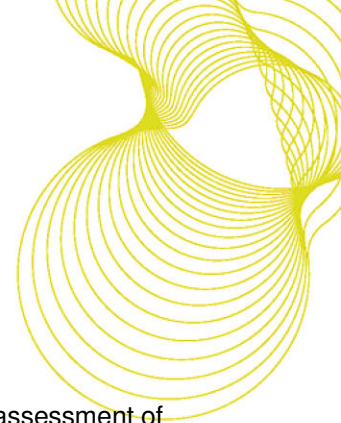

Introduction

BRE has been commissioned by Thermohouse, of MGC Group Ltd, in order to provide an assessment of the thermal performance of an ICF wall construction design and of a roof panel design. Thermohouse have provided drawings and for clarity the drawings are reproduced in this report.

A U-value is a measure of the quantity of heat that will flow through unit area in unit time, per unit difference in temperature between the internal and external environment. It is expressed in W/m^2K . A surface temperature factor (f_{Rsi} -factor) is an indication of the minimum temperature of an internal surface for a given set of internal and external conditions and this gives an indication of the risk of surface condensation.

Thermal performance requirements for buildings are set out in Part L of the Building Regulations^[Ref 3]. The thermal performance of external elements may be calculated using EN ISO 10211^[1,2] and this report sets out the results of 3-dimensional thermal performance calculations, using the methods in EN ISO 10211. The calculations were carried out using Physibel's Trisco software and this report presents the methodology, results and interpretation of the thermal performance calculations.

The minimum surface temperature factor (which is defined in BRE IP 1/06^[Ref 4]) is a measure of the degree of thermal bridging and it gives an indication of the risk of condensation. A high f_{Rsi} -factor indicates a relatively low risk of inside surface condensation while a low f_{Rsi} -factor indicates a high risk. The risk of condensation also depends upon the type of building and the use to which it is put. For example, a swimming pool or data centre may incur a higher risk of condensation than an office or warehouse. The relevant Building Regulations should be referred to in order to determine the requirements as regards thermal bridging and risk of surface condensation.

The results of these calculations are presented in the following sections and are intended to serve as guidance for assessing compliance with Building Regulations.

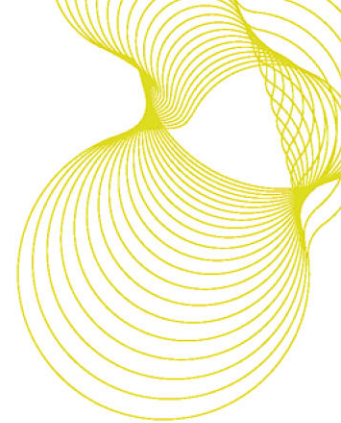

The wall and roof constructions

The ICF wall construction

The U-values of the ICF wall construction variations were evaluated using the procedures in EN ISO 10211, which give relevant guidance on numerical modelling. The modelling takes account of the dimensions and thermal conductivities of the materials making up the ICF external wall construction. It also takes account of the surface effects according to current standards. The external wall designs which were assessed are described in Appendix A.

The U-value and minimum surface temperature factor (f_{Rsi}) were calculated and the results are shown in Table 1.

	Higher Conductivity (EPS – 0.035 W/m·K)	Lower Conductivity (EPS – 0.030 W/m·K)
U-value (W/m ² K)	0.23	0.20
Minimum surface temperature factor, f_{Rsi}	0.967	0.974

Table 1 U-values and minimum surface temperature factors of the variation of Thermohouse 300

The roof panel construction

The roof panel design consists of 235 mm expanded polystyrene (0.030 W/m·K) with 15mm top ribs, with a 15 mm internal layer of gypsum plaster (thermal conductivity 0.26 W/m·K). Steel channels penetrate the insulation to provide mechanical support. Immediately above the roof space is a set of battens and counterbattens and a breathable membrane with roof tiles above the membrane. Details of the roof panel are shown in Appendix B.

The U-value and minimum surface temperature factor (f_{Rsi}) were calculated and the results are shown in Table 2.

	Roof panel (EPS – 0.035 W/m·K)
U-value (W/m ² K)	0.15
Minimum surface temperature factor, f_{Rsi}	0.983

Table 2 U-values and minimum surface temperature factors for the roof panel

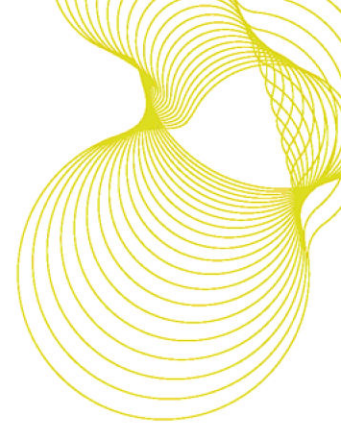

Results

Results are given for both the ICF wall design and the roof panel construction.

The ICF wall

The U-value and minimum surface temperature factors (f_{Rsi}) of the proposed ICF wall construction variations have been determined by numerical modelling and conclusions presented in this report. The following points are concluded:-

- The minimum surface temperatures are compliant with the requirements in the BRE Information Paper IP1/06. The minimum surface temperature factor (f_{Rsi}) was found to be acceptable. The higher conductivity model produced a minimum surface temperature factor of 0.967, the lower conductivity model produced a factor of 0.974.
- The U-value of the higher conductivity model ($\lambda = 0.035 \text{ W/m}\cdot\text{K}$) was found to be $0.23 \text{ W/m}^2\text{K}$. As expected, the lower conductivity model ($\lambda = 0.030 \text{ W/m}\cdot\text{K}$) produced an improved U-value of $0.20 \text{ W/m}^2\text{K}$.
- The U-value was also calculated for the lower conductivity model, but without taking into account the impact of the steel fixings. This resulted in a U-value of $0.18 \text{ W/m}^2\text{K}$, meaning the steel fixings cause an increase to the U-value of $0.016 \text{ W/m}^2\text{K}$

The roof panel

The U-value and minimum surface temperature factors (f_{Rsi}) of the proposed roof panel construction have been determined by numerical modelling and conclusions presented in this report. The following points are concluded:-

- The minimum surface temperatures are compliant with the requirements in the BRE Information Paper IP1/06. The minimum surface temperature factor (f_{Rsi}) of 0.98 was found to be acceptable.
- The U-value of the roof panel was found to be $0.15 \text{ W/m}^2\text{K}$.

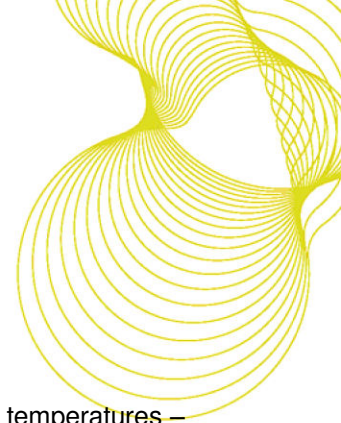

References

- [1] EN ISO 10211-1 Thermal bridges in building construction – Heat flows and surface temperatures – Part 1: General calculation methods
- [2] EN ISO 10211-2 Thermal bridges in building construction – Heat flows and surface temperatures – Part 2: Linear thermal bridges
- [3] Building Regulations 2008, Technical Guidance Document L, Conservation of Fuel and Energy, Department of the Environment, Heritage and Local Government
- [4] BRE Information Paper IP 1/06
- [5] BR497 Conventions for calculating linear thermal transmittance and temperature factors, T Ward and C Sanders, IHS BRE Press 2007

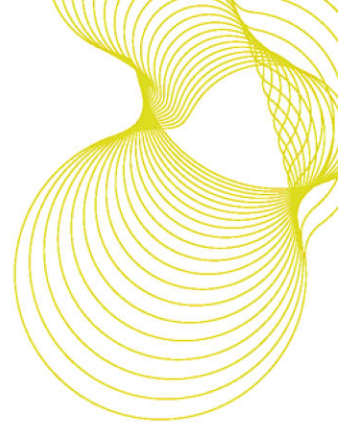

Appendix A: Technical Information regarding the ICF wall

Figure A.1.1 shows a cross-section of the external wall design and Figure A1.2 shows an overview.

The external wall variations were modelled in order to assess their thermal performance. The calculations were carried out with a notional internal temperature of 20°C and a notional external temperature of 0°C.

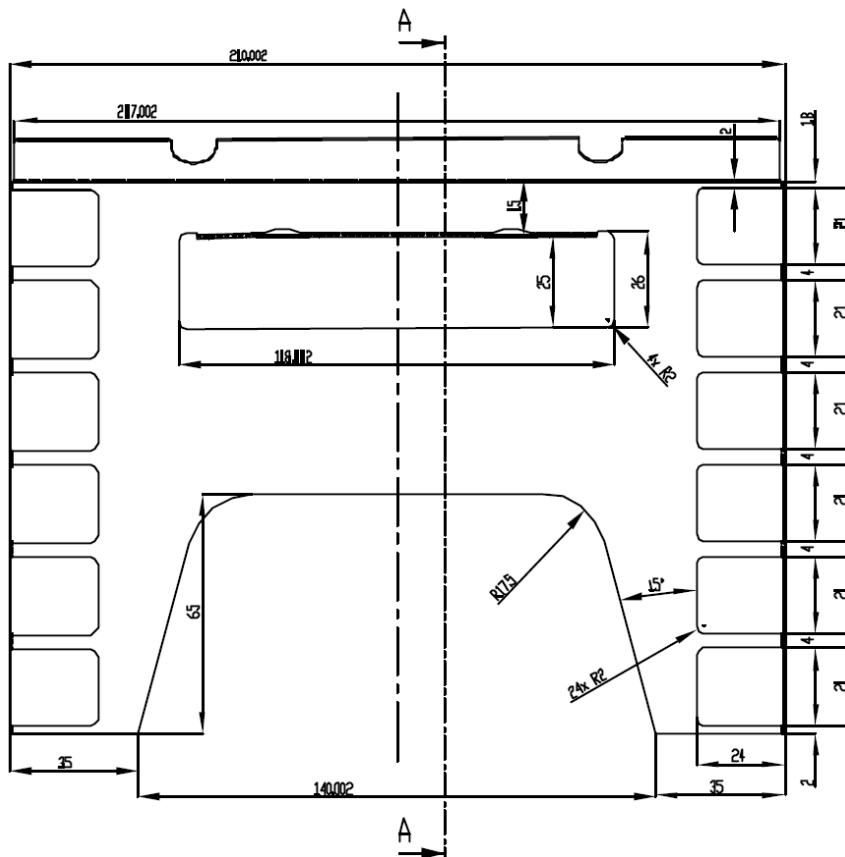

Figure A.1.1 The ICF wall construction design as provided by MCG Group Ltd (note: there are three modifications. (A) An external render of 12.5mm has been included. (B) A 50mm cavity with 50x50mm timber studs at 400mm centres has been included. (C) An internal plasterboard finish of 12.5mm has been included.

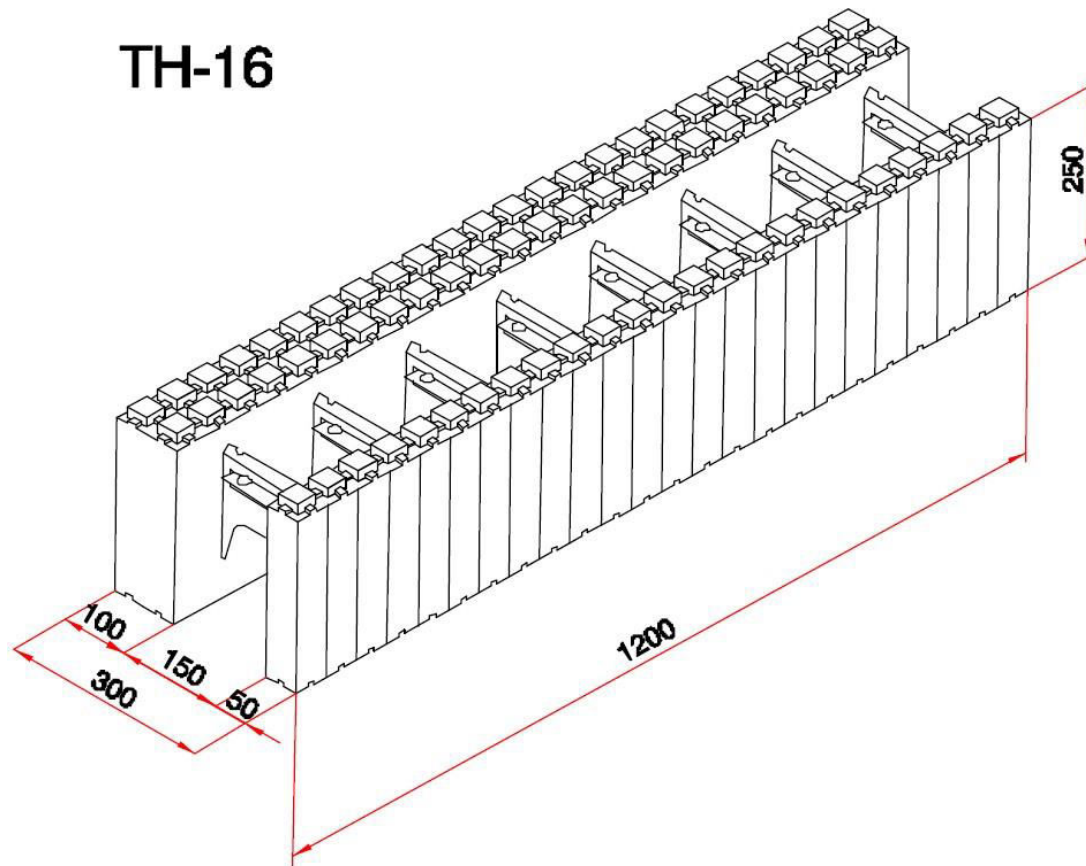

Figure A.1.2 An overview of the wall system. The poured concrete is dense structural concrete with a typical density of 2400 kg/m^3 . Guidance is given in Technical Guidance Document L of the building regulations.

Table A.2.1 shows the conductivities of the materials and air spaces used in the numerical modelling.

Material	Thermal conductivity in W/m·K
Plasterboard	0.21
Cavity (50mm)	0.277
Timber (softwood)	0.13
EPS (Higher Conductivity)	0.035
EPS (Lower Conductivity)	0.030
Concrete (Density of 2400 kg/m^3)	2.0
Render	0.26
Steel	50.0

Table A.2.1 Thermal conductivities of the materials

The layers for Thermohouse 300 are as in Tables A.2.2 and A.2.3.

Outer extent of section	Inner extent of section	Thickness (mm)
Internal side of gypsum skim	Outer side of gypsum skim	4
Internal side of plasterboard	Outer side of plasterboard	12.5
Inner side of cavity	Outer side of cavity	50
Inner side of EPS	Outer side of EPS	50
Inner side of concrete	Outer side of concrete	150
Inner side of EPS	Outer side of EPS	100
Inner side of render	Outer side of render	12.5

Table A.2.2 Section dimensions used in the numerical modelling

Top of layer	Bottom of layer	Thickness (mm)
Adiabatic boundary	Top of upper section of construction	50
Top of upper section of construction	Top of steel fixing	150
Top of steel fixing	Top of lower section of construction	50
Top of lower section of construction	Adiabatic boundary	-

Table A.2.3 Layer dimensions used in the numerical modelling

U-Value and minimum internal surface temperature factor calculations are in Tables A3.1, 3.2 and 3.3.

'Higher Conductivity' ICF Wall	Result	Unit
Thickness of internal gypsum skim	4	mm
Total heat transfer, Φ	1.35130	W
Lateral dimension of model, b_1 (horizontal)	1200	mm
Lateral dimension of model, b_2 (vertical)	250	mm
Area of model in plane perpendicular to principal direction of heat transfer, $b_1 \times b_2$	0.3	m ²
Internal environmental temperature, T_i	20	°C
External environmental temperature, T_e	0	°C
U-value, $\Phi / ((T_i - T_e) \times (b_1 \times b_2))$	0.225	W/m²K
Minimum internal surface temperature	19.39	°C
Minimum surface temperature factor, f_{Rsi}	0.97	-

Table A3.1 A summary of the results of the numerical modelling calculations for the Higher Conductivity variation (EPS – 0.035 W/m•K)

'Lower Conductivity' ICF Wall	Result	Unit
Thickness of internal gypsum skim	4	mm
Total heat transfer, Φ	1.1833	W
Lateral dimension of model, b_1 (horizontal)	1200	mm
Lateral dimension of model, b_2 (vertical)	250	mm
Area of model in plane perpendicular to principal direction of heat transfer, $b_1 \times b_2$	0.3	m ²
Internal environmental temperature, T_i	20	°C
External environmental temperature, T_e	0	°C
U-value, $\Phi / ((T_i - T_e) \times (b_1 \times b_2))$	0.197	W/m²K
Minimum internal surface temperature	19.47	°C
Minimum surface temperature factor, f_{Rsi}	0.974	-

Table A3.2 A summary of the results of the numerical modelling calculations for the Higher Conductivity variation (EPS – 0.030 W/m•K)

'Lower Conductivity' with no steel fixings	Result	Unit
Thickness of internal gypsum skim	4	mm
Total heat transfer, Φ	1.08781	W
Lateral dimension of model, b_1 (horizontal)	1200	mm
Lateral dimension of model, b_2 (vertical)	250	mm
Area of model in plane perpendicular to principal direction of heat transfer, $b_1 \times b_2$	0.3	m ²
Internal environmental temperature, T_i	20	°C
External environmental temperature, T_e	0	°C
U-value, $\Phi / ((T_i - T_e) \times (b_1 \times b_2))$	0.181	W/m²K
Minimum internal surface temperature	19.52	°C
Minimum surface temperature factor, f_{Rsi}	0.976	-

Table A3.3 A summary of the results of the numerical modelling calculations for the Higher Conductivity variation (EPS – 0.030 W/m•K) with the steel fixings removed

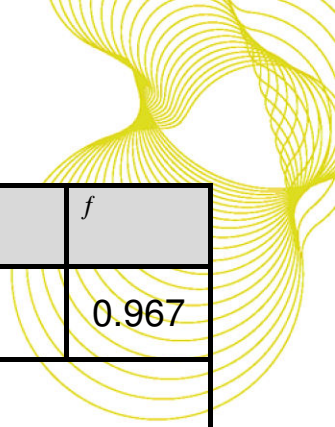

V_1	Thermodeck 300 EPS thermal conductivity – 0.035 W/m·K	U_{wall}	f
	ICF Wall Construction	0.23	0.967

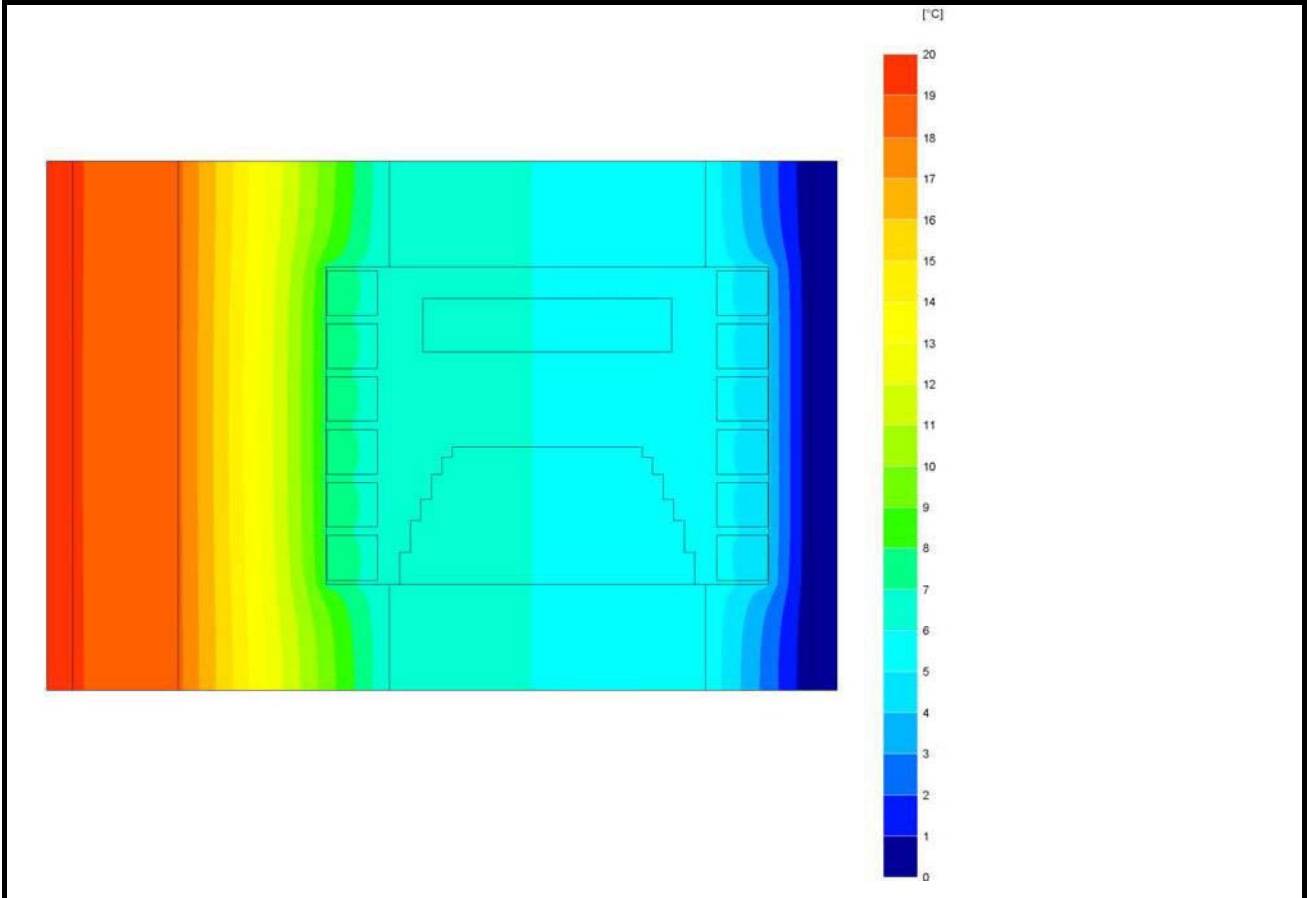
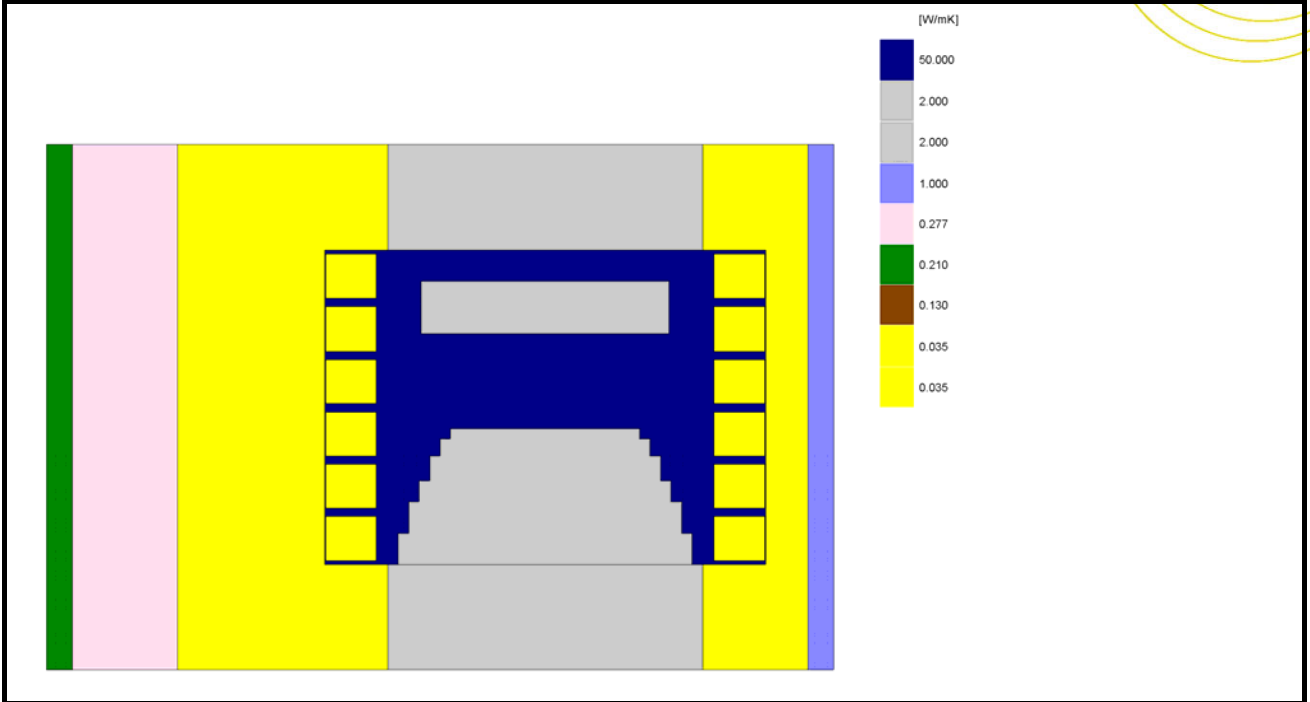

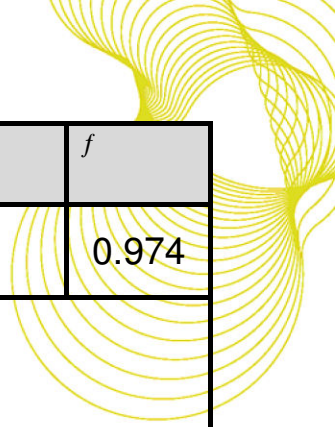

V_2	Thermodeck 300 EPS thermal conductivity – 0.030 W/m·K	U_{wall}	f
	ICF Wall Construction	0.20	0.974

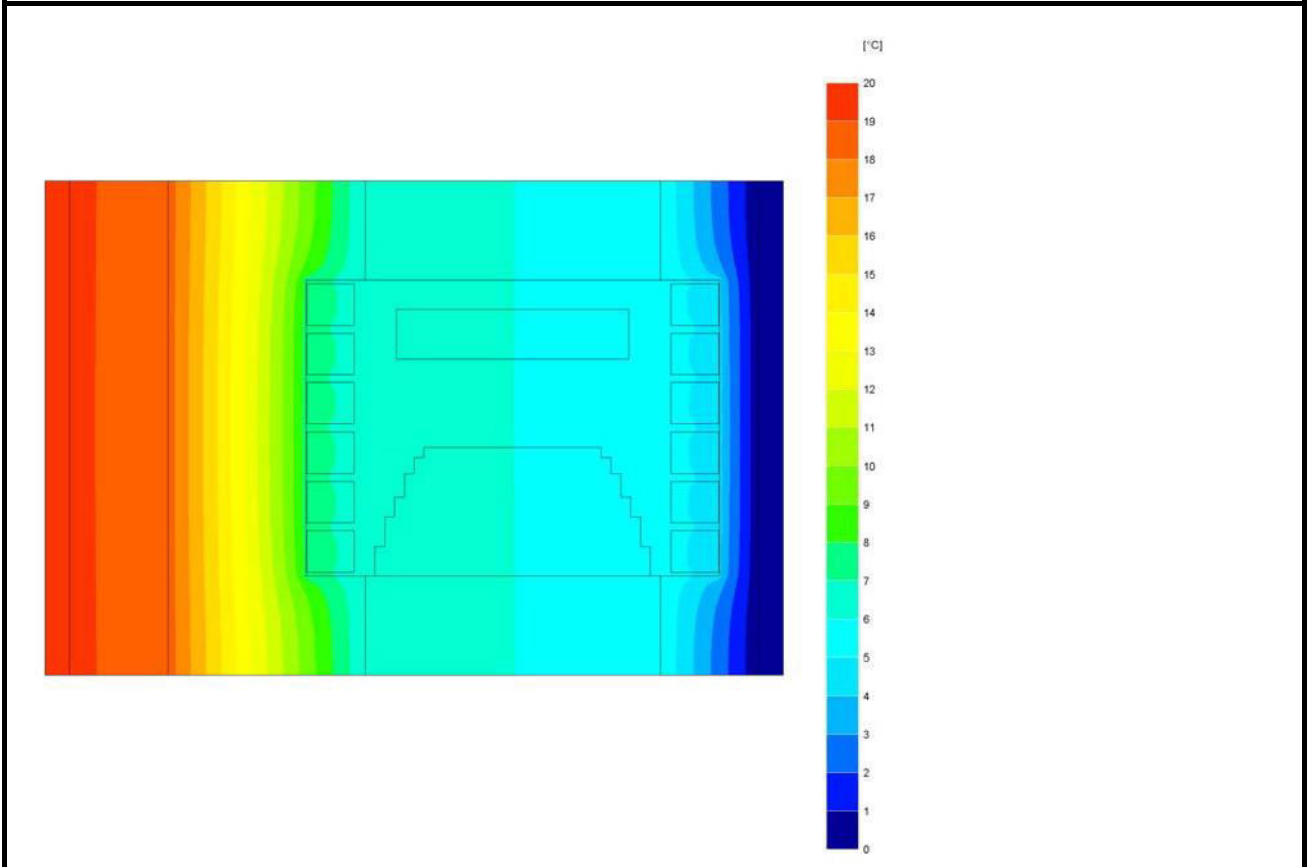
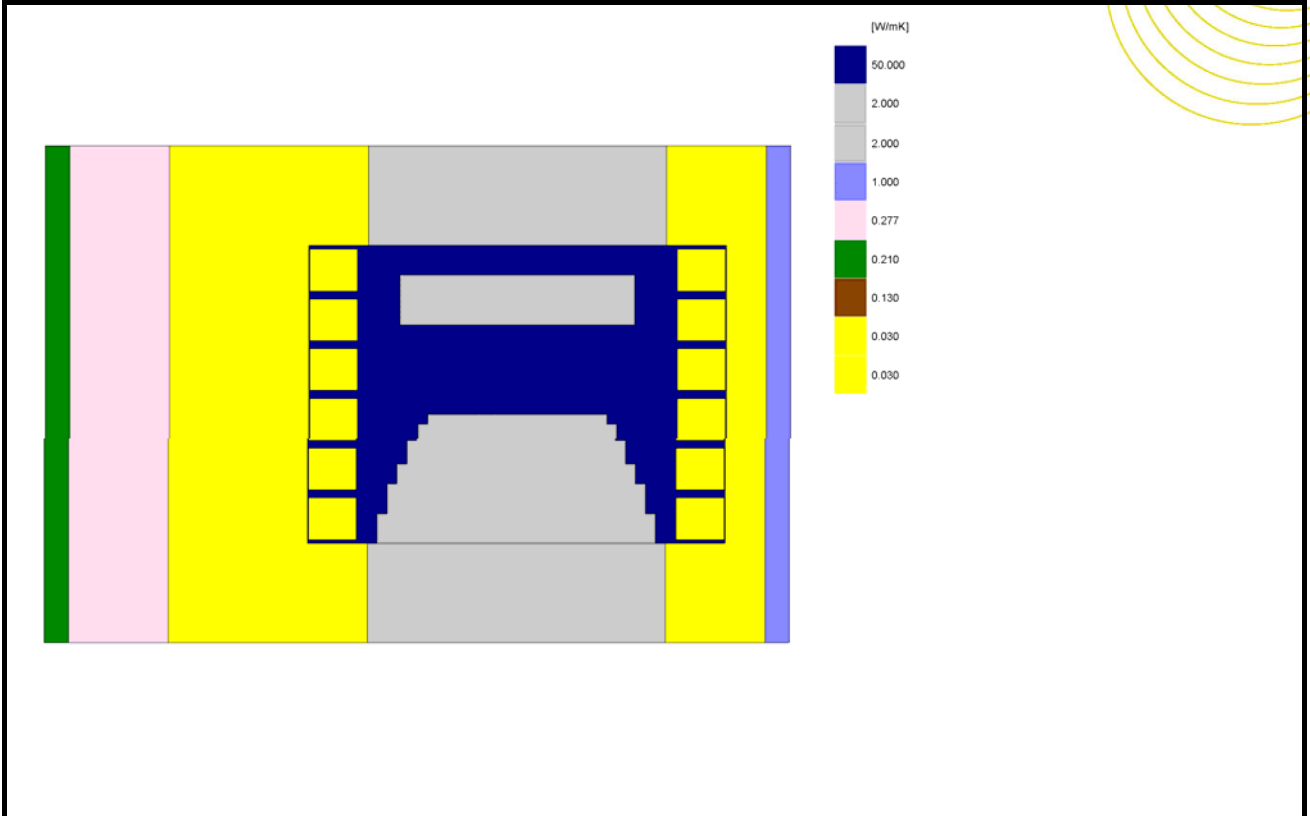

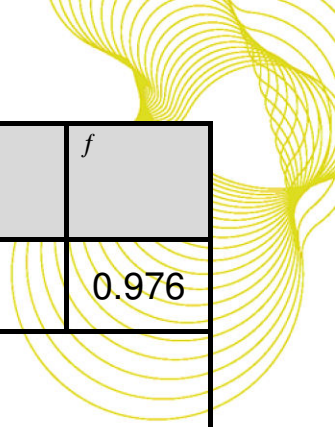

V_3	Thermodeck 300 EPS thermal conductivity – 0.03 W/m·K No steel fixings	U_{wall}	f
	ICF Wall Construction	0.18	0.976

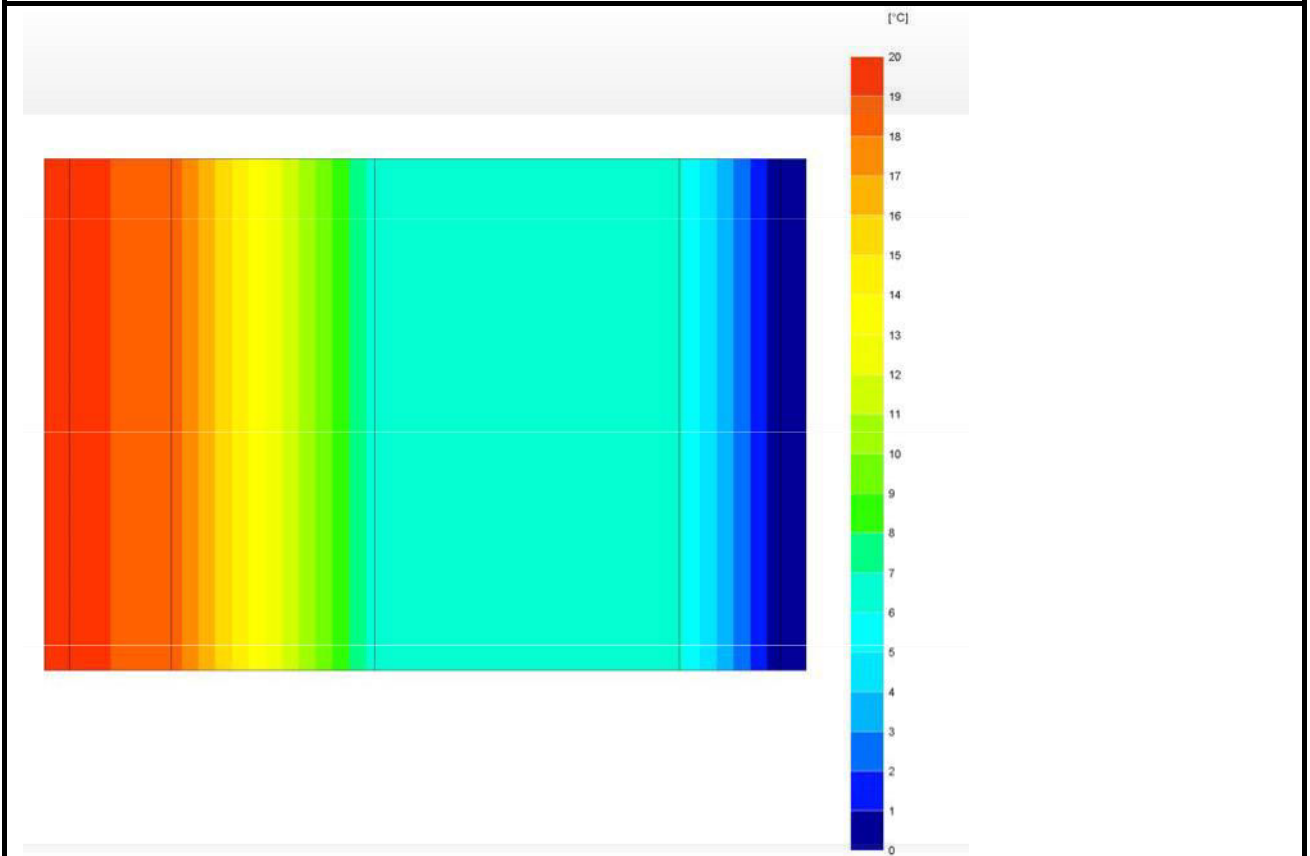
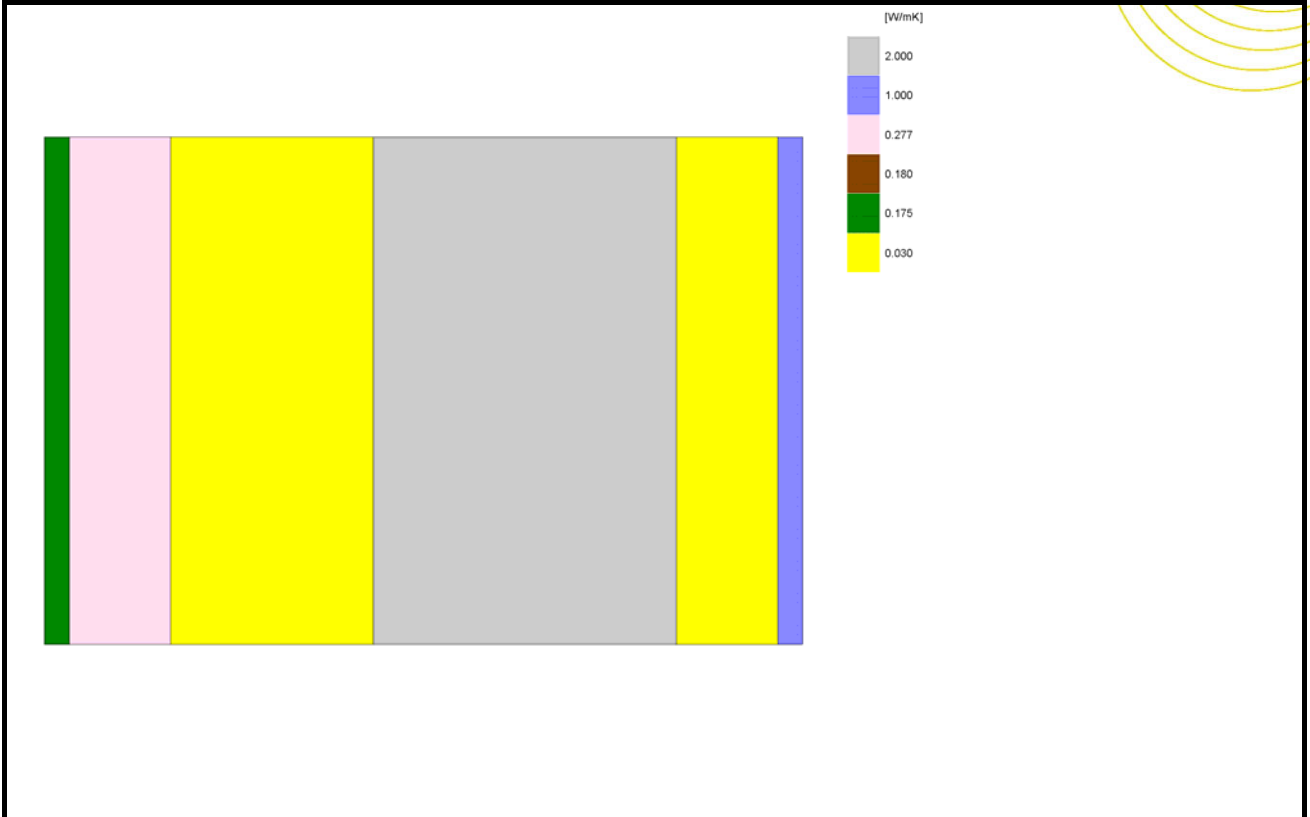

Appendix B Technical information regarding the roof panel

Thermal modelling calculations were carried out on a roof panel design consisting of 235 mm thick expanded polystyrene (250 mm thick at the ribs) with a 15 mm internal layer of gypsum plaster (thermal conductivity 0.26 W/m·K). To the external side of the expanded polystyrene is a roof space with 50 mm × 50 mm timber counter battens, 50 mm × 38 mm timber roof battens, one layer of breathable membrane and roof tiles. 100 mm high steel channels penetrate the insulation to provide mechanical support. The centre-to-centre spacing of the steel channels is 255 mm.

Table B.1 summarises the dimensions and thermal conductivity values of the various parts of the thermal model of the roof panel.

Description	Thermal Conductivity W/mK	Horizontal dimension mm	Vertical dimension mm	Minimum horizontal position mm	Maximum horizontal position mm	Minimum vertical position mm	Maximum vertical position mm
EPS	0.030	255	235	0	255	115	350
plaster	0.260	255	15	0	255	100	115
steel	50.000	50	1.2	102.5	152.5	220	221.2
steel	50.000	50	1.2	102.5	152.5	318.7	320
steel	50.000	1.2	100	151.3	152.5	220	320

Table B.1 The dimensions and thermal conductivities of the parts making up the model

Roof panel	Result	Unit
Lateral dimension of model, parallel to steel channels, b_1	1000	mm
Lateral dimension of model, perpendicular to steel channels, b_2	255	mm
Centre to centre spacing of the steel channels	255	mm
Thermal conductivity of the EPS roof insulation	0.030	W/m·K
Thermal conductivity of the 15 mm plaster	0.26	W/m·K
Thickness of steel channels	1.2	mm
Area through which heat passes	0.255	m ²
Heat transfer through the roof panel section	0.780	W
Temperature at warm side of panel	20	°C
Temperature at cold side of panel	0	°C
U-value of roof panel	0.15	W/m²K
Minimum surface temperature	19.66	°C
Minimum surface temperature factor	0.983	-

Table B.2 A summary of the results of the numerical modelling calculations for roof panel

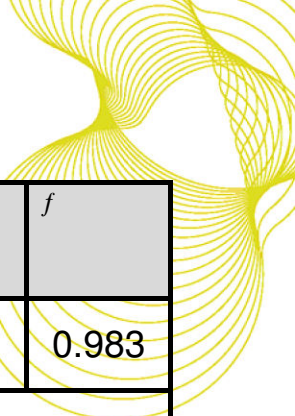

	Thermohouse roof panel	U	<i>f</i>
		0.15	0.983

