



NSAI
Agrément

CERTIFICATE NO. 08/0310

Thermohouse Ltd., Coolcaslagh,
Killarney, Co. Kerry.
Tel: 064 6631307
Fax: 064 6632394
Email: info@thermohouse.ie
Website: www.thermohouse.ie

Thermohouse ICF System

Système pour construction Bausystem

The **Irish Agrément Board** is designated by Government to issue European Technical Approvals.

Irish Agrément Board Certificates establish proof that the certified products are '**proper materials**' suitable for their intended use under Irish site conditions, and in accordance with the **Building Regulations 1997 to 2011**.

The **Irish Agrément Board** operates in association with the **National Standards Authority of Ireland (NSAI)** as the National Member of UEAtc.



PRODUCT DESCRIPTION:

This Certificate relates to the Thermohouse ICF (Insulating Concrete Formwork) System, which consists of modular interlocking expanded polystyrene (EPS) building blocks (standard white and grey) for permanent formwork for the construction of in-situ concrete walls. An external render system approved by NSAI Agrément for use with ICF systems is applied to the external polystyrene insulation of the Thermohouse ICF system as the external finish. Alternative finishes may be used in accordance with the Thermohouse ICF installation manual. Internally, the plasterboard is fixed directly through the EPS into the concrete core with plastic insulated anchors, or alternatively screwed to timber battens. An NSAI Agrément approved internal plaster may also be used as an alternative finish. This Certificate certifies compliance with the requirements of the Building Regulations 1997 to 2011.

USE:

The Thermohouse ICF System is certified for use in the construction of buildings up to six storeys in height.

The system has been assessed for use as load bearing and non-load bearing walls in the construction of specifically designed buildings. Fire and sound rated walls may also be constructed using the system.

MANUFACTURE AND MARKETING

The product is manufactured and marketed by:

Thermohouse Ltd.,
Coolcaslagh,
Killarney,
Co. Kerry.
Tel: 064 6631307
Fax: 064 6632394
Email: info@thermohouse.ie
Website: www.thermohouse.ie

1.1 ASSESSMENT

In the opinion of NSAI Agrément, the Thermohouse ICF System when used as specified in this NSAI Agrément certificate is satisfactory for the purpose defined above, and meets the requirements of the Building Regulations 1997 - 2011 as indicated in Section 1.2 of this Certificate.

1.2 BUILDING REGULATIONS 1997 to 2011

REQUIREMENT:

Part D - Materials and Workmanship

D3 – The Thermohouse ICF System, as certified in this Certificate, is comprised of proper materials fit for their intended use (see Parts 3 and 4 of this Certificate).

D1 – The Thermohouse ICF System, used in accordance with this Certificate, meets the requirements for workmanship.

Part A – Structure

A1 – Loading

The Thermohouse ICF System, as certified in this Certificate, has adequate strength and stability (see Parts 3 and 4 of this Certificate).

Part B – Fire Safety

B1 – Means of Escape In Case of Fire

The Thermohouse ICF System can be designed to meet the requirements in respect of means of escape in case of fire.

B2 – Internal Fire Spread (linings)

The NSAI Agrément approved internal plaster finish for ICF systems and plasterboard slabs used on the internal finish of the Thermohouse ICF System are non-combustible and have a Class 0 'spread of flame' rating. Surface spread of flame rating of the finished construction will be determined by the surface spread of flame rating of the lining materials used.

B3 – Internal Fire Spread (structure)

The Thermohouse ICF System, as certified in this Certificate, will meet this requirement.

B4 – External Fire Spread

External renders approved for use with the Thermohouse ICF System have a spread of flame rating equivalent to Class 0 on both faces. In respect of 'Spread of Flame', this is the highest performance classification set out in the Building Regulations 1997 to 2011.

Part C – Site Preparation and Resistance to Moisture

C3 – Dangerous Substances

Where it is shown that protection from dangerous substances such as radon is required, an approved gas resistant membrane and gas handling system must be provided under the ground floor, in accordance with Part C of the Building Regulations 1997 to 2011. The Thermohouse ICF System permits the easy

incorporation of the appropriate membrane, sump and gas handling system.

C4 – Resistance to Weather and Ground Moisture

The Thermohouse ICF System, used in accordance with Part 3 of this Certificate, will have adequate weather resistance in all exposures, will resist the passage of moisture from whatever source and will prevent surface or interstitial condensation.

Part E – Sound

E1 – Airborne Sound (Walls)

Compartment walls (i.e. party walls) are designed and constructed to meet the airborne sound requirements of this Regulation.

E2 and E3 – Airborne and Impact Sound (Floors)

Intermediate and separating floors can be constructed to meet the airborne sound requirements of this Regulation.

Part F – Ventilation

F1 – Means of Ventilation

A mechanical ventilation system should be installed into the thermal airtight envelope which the Thermohouse system provides. Alternatively, adequate building ventilation openings can be provided in walls constructed with the Thermohouse ICF System. It is essential that ventilation ducts through such walls are fully sealed within the walls or from contact with the cut edges of adjacent materials.

F2 – Condensation in Roofs

Adequate ventilation can be provided in roofs to meet this requirement in respect of the prevention of condensation.

Part J – Heat Producing Appliances

J3 – Protection of Building

When the Thermohouse ICF System is used in accordance with Section 4.1 of this Certificate, wall lining, insulation and separation distances meet the Regulation requirements.

Part L – Conservation of Fuel and Energy

L1 – Conservation of Fuel and Energy

The Thermohouse ICF System will contribute to enabling a building to meet this requirement. U value and Psi value calculations may be based on a λ value = 0.035 W/mK for standard white EPS and 0.030 W/mK for graphite-enhanced EPS. The calculated U-value for the standard Thermohouse ICF 150 and 200mm wall is 0.23W/m²K using standard white EPS, this value will improve to 0.20W/m²K when using graphite enhanced EPS. By increasing the external element of the formwork, this value can be improved, up to 0.10W/m²K.

Part M – Access for People with Disabilities

M1 – Access and Use

Buildings based on the Thermohouse ICF System can be designed to meet the access, circulation and facilities requirements of this Regulation.

2.1 PRODUCT DESCRIPTION

2.1.1 General

The Thermohouse ICF System consists of moulded panels of expanded polystyrene linked together with steel ties. The panels are butt jointed and are placed with staggered vertical joints. Thermohouse rebated blocks are used at each location where doors and windows are required.

The units are erected as formwork into which vertical and horizontal reinforcement is placed and then filled with concrete and vibrated to create a monolithic concrete wall. The poured wall then retains the Thermohouse formwork insulation for the life of the building.

The Thermohouse panels are manufactured from fire retardant grade in accordance with IS EN 13163:2001 *Thermal insulation products for buildings – Factory made products of expanded polystyrene – Specification*, without the use of HCFC's. The minimum density is 24kg/m³.

2.1.2 Structure

The concrete specification is as follows:

- Minimum concrete cube strength: C30/25
- Maximum aggregate size: 10mm
- Concrete slump: S3 (110 – 140mm)

2.1.3 Steel Reinforcement

The steel reinforcement to be used should be 12mm diameter round or deformed bars, high tensile to BS 4449:2005 *Steel for the reinforcement of concrete – Weldable reinforcing steel – Bar, coil and decoiled product – Specification*, BS 4482:2005 *Steel wire for the reinforcement of concrete products – Specification*, BS 4483:2005 *Steel fabric for the reinforcement of concrete – Specification*, and IS EN 10020:2000 *Definition and classification of grades of steel*, and have a maximum yield strength of 500N/mm².

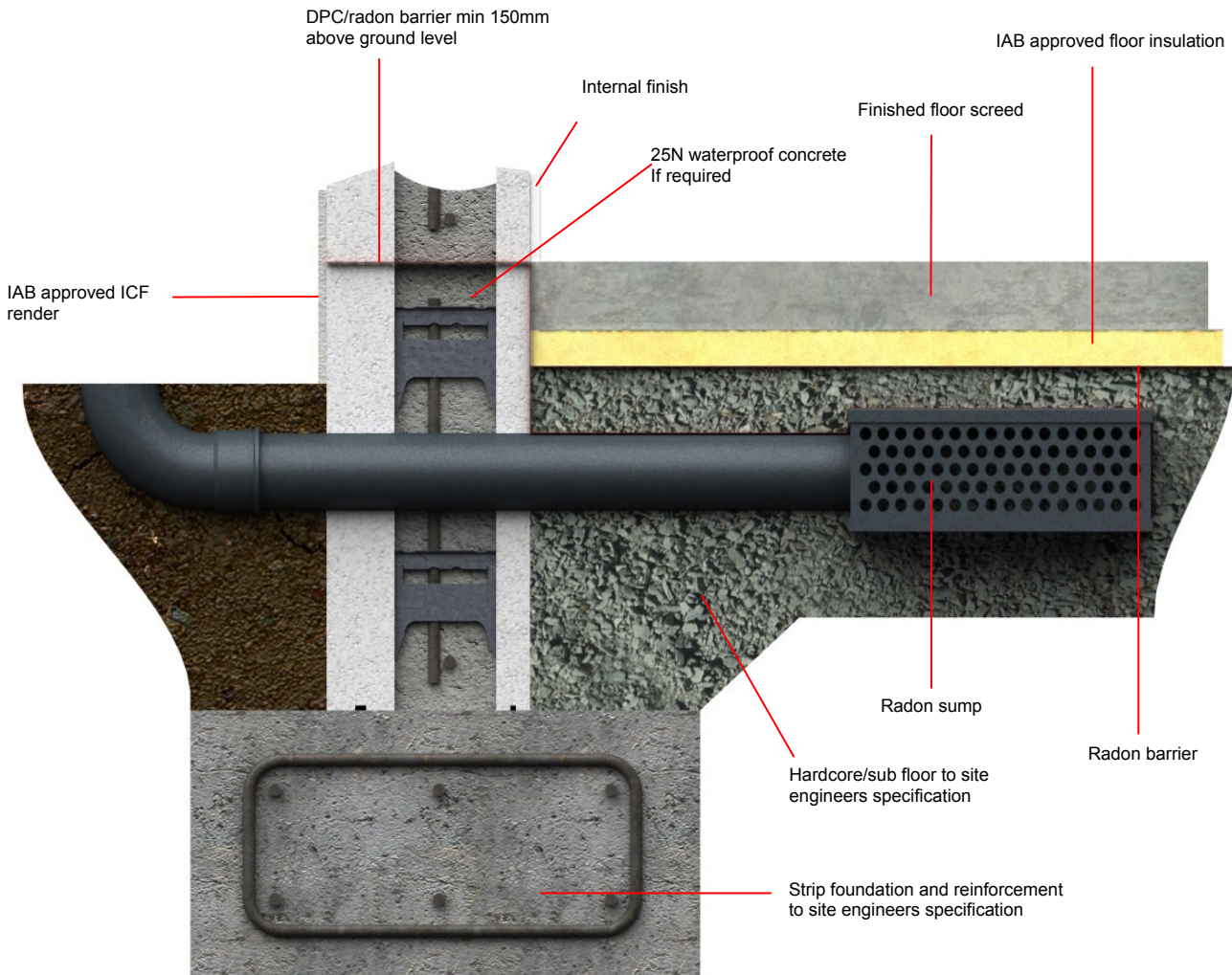

Figure 1: Strip Foundation Details

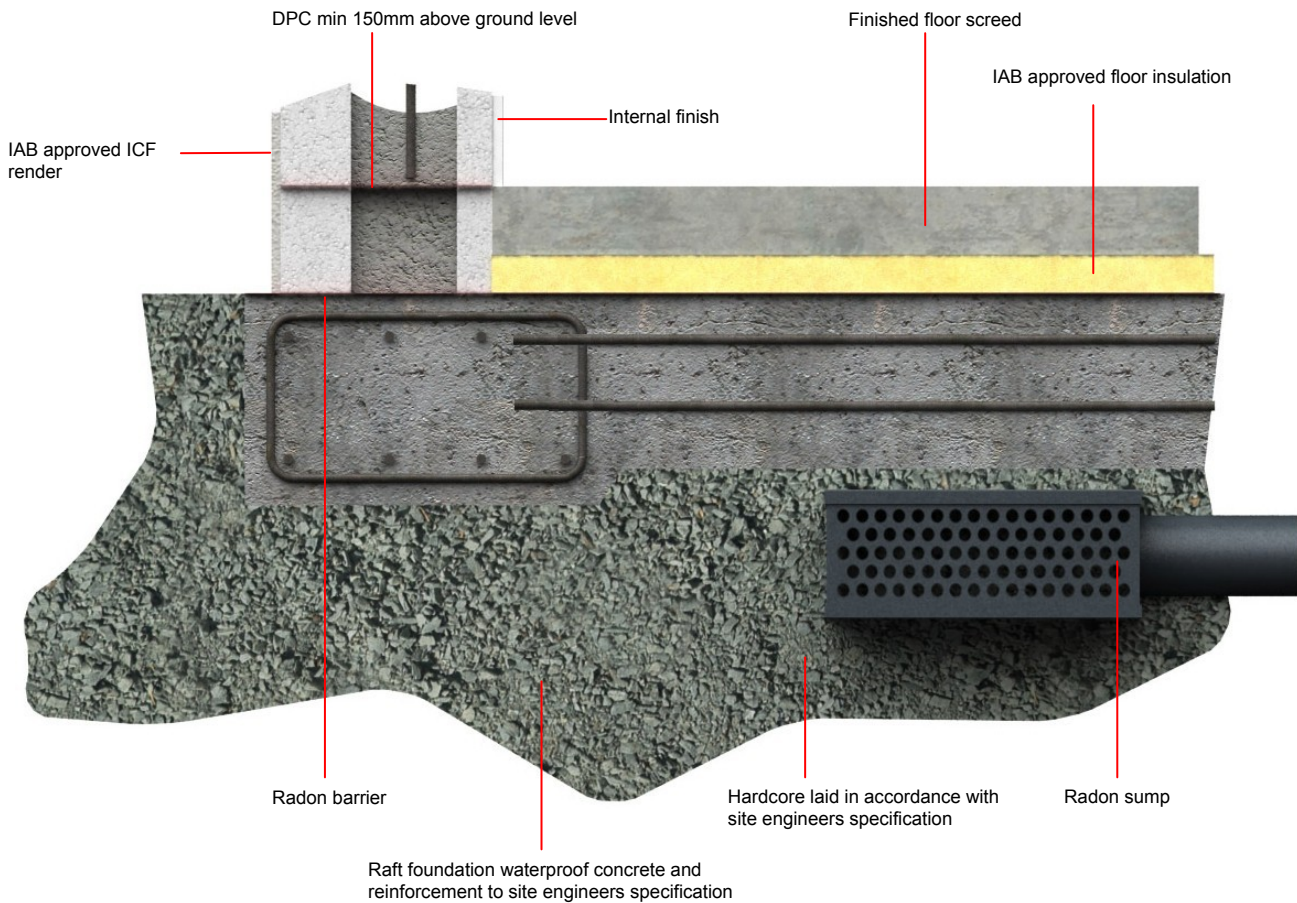

Figure 2: Raft Foundation Details

2.1.4 Foundations

The foundations are not part of the Thermohouse ICF System and are not covered by this Certificate. Foundation design must comply with Part A of the Building Regulations 1997 to 2011.

2.1.5 External Walls

The different elements of the external wall are as follows:

- 12mm minimum NSAI Agrément approved external render for use with ICF system
- 100 – 250mm ICF EPS outer leaf
- 150 – 200mm reinforced concrete core and ICF steel ties
- 50mm ICF EPS inner leaf
- 12.5mm plasterboard slabs fixed directly through the EPS into the concrete core with plastic insulated anchors, or alternatively screwed to timber battens. An NSAI Agrément approved internal plaster may also be used as an alternative finish
- 4mm gypsum skim coat plaster

The external renders certified for use with ICF systems are described in their own Certificates. Using the elemental U-value calculation method, the U-value of this wall varies from 0.23 – 0.10W/m²K.

2.1.6 Compartment Walls (Party Walls)

The compartment wall consists of the following:

- 4mm gypsum skim coat plaster

- 12.5mm plasterboard slabs fixed directly through the EPS into the concrete core with plastic insulated anchors, or alternatively screwed to timber battens. An NSAI Agrément approved internal plaster may also be used as an alternative finish
- 50mm EPS panel
- 200mm reinforced concrete core and steel ties
- 50mm EPS panel
- 12.5mm plasterboard slabs nail or screw fixed to timber battens fixed to the concrete core, or NSAI Agrément approved internal plaster finish for use with ICF systems
- 4mm gypsum skim coat plaster

With regard to sound transmission, the Thermohouse ICF 200mm wall has a mass of 490kg/m² and this meets the requirements of Diagram 5 of Technical Guidance Document (TGD) to Part E of the Building Regulations 1997 to 2011.

2.1.7 Internal Walls

Load bearing internal walls are constructed using either the 150mm or 200mm concrete core Thermohouse ICF forms, and slabbed and plastered as above for the party wall.

2.1.8 Floors

The Thermohouse wall system enables the use of different flooring systems including the Thermohouse Floor System, pre-cast concrete floors, metal decking

and timber joists. All flooring systems must be installed in accordance with the manufacturer's instructions.

2.1.9 Roof

The Thermohouse ICF System allows the use of the NSAI Agrément certified Thermohouse Roof System. The Thermohouse ICF System also allows for the supply by others of a conventional timber or trussed roof with slating or tiling in accordance with ICP 2:2002.

2.1.10 Stairs

Stairs are not part of the Thermohouse ICF System and are not covered by this Certificate.

Property	Test Method	Value
Declared Thermal Conductivity (50mm)	IS EN 12667	0.035W/mK Or 0.030 W/mK
Compressive Strength at 10% Deformation	IS EN 826	150kN/m ²
Bending Strength	IS EN 12089	2.0kN/m ²
EPS Density	IS EN 1602	Min 24kg/m ³
Reaction to Fire	IS EN ISO 11925-2, IS EN 13501-1	Euroclass E
Water Vapour Permeability	IS EN 12086, IS EN ISO 12572	33g/m ² /day

Table 1: Properties of Polystyrene used in Thermohouse ICF System

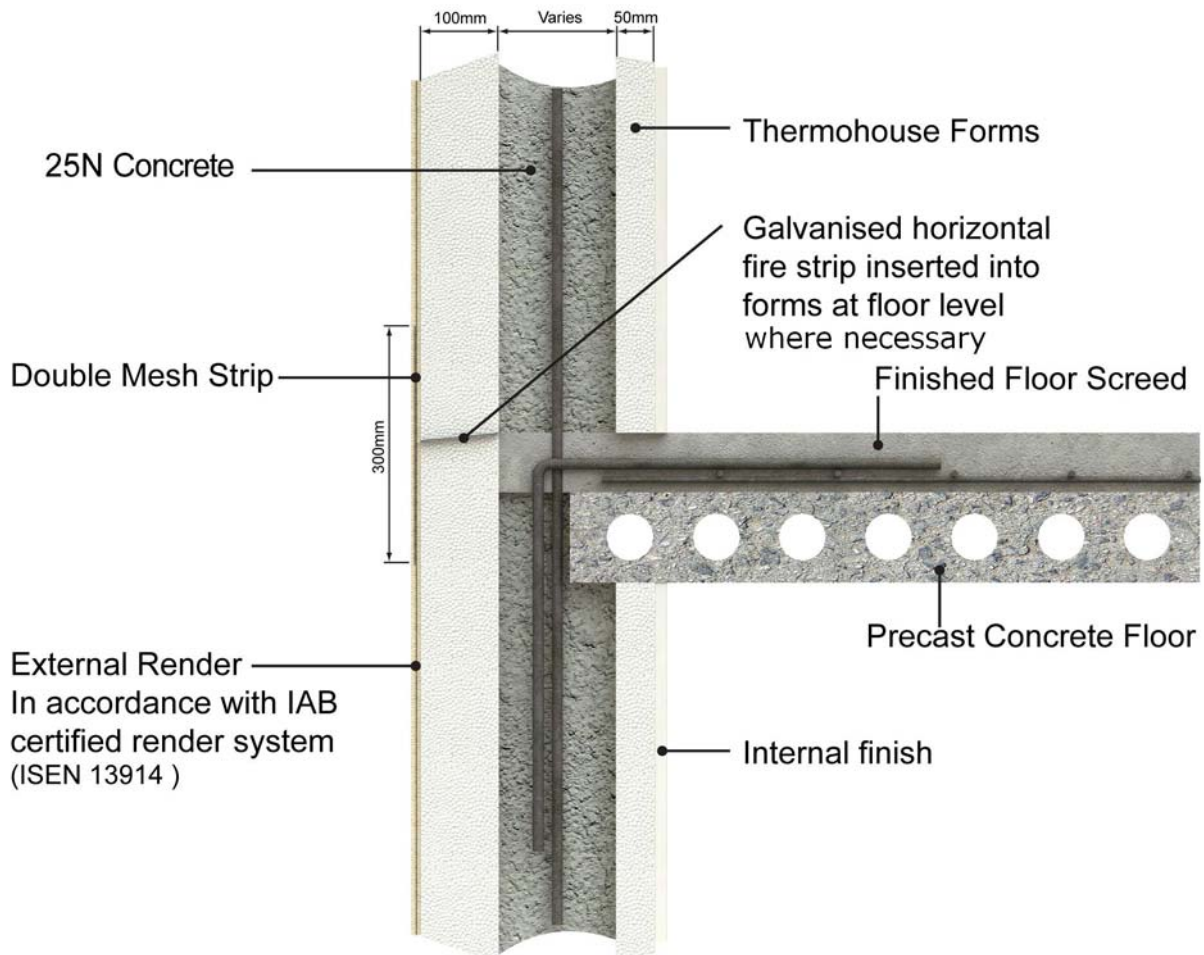

Figure 3: Precast Concrete Floor Details

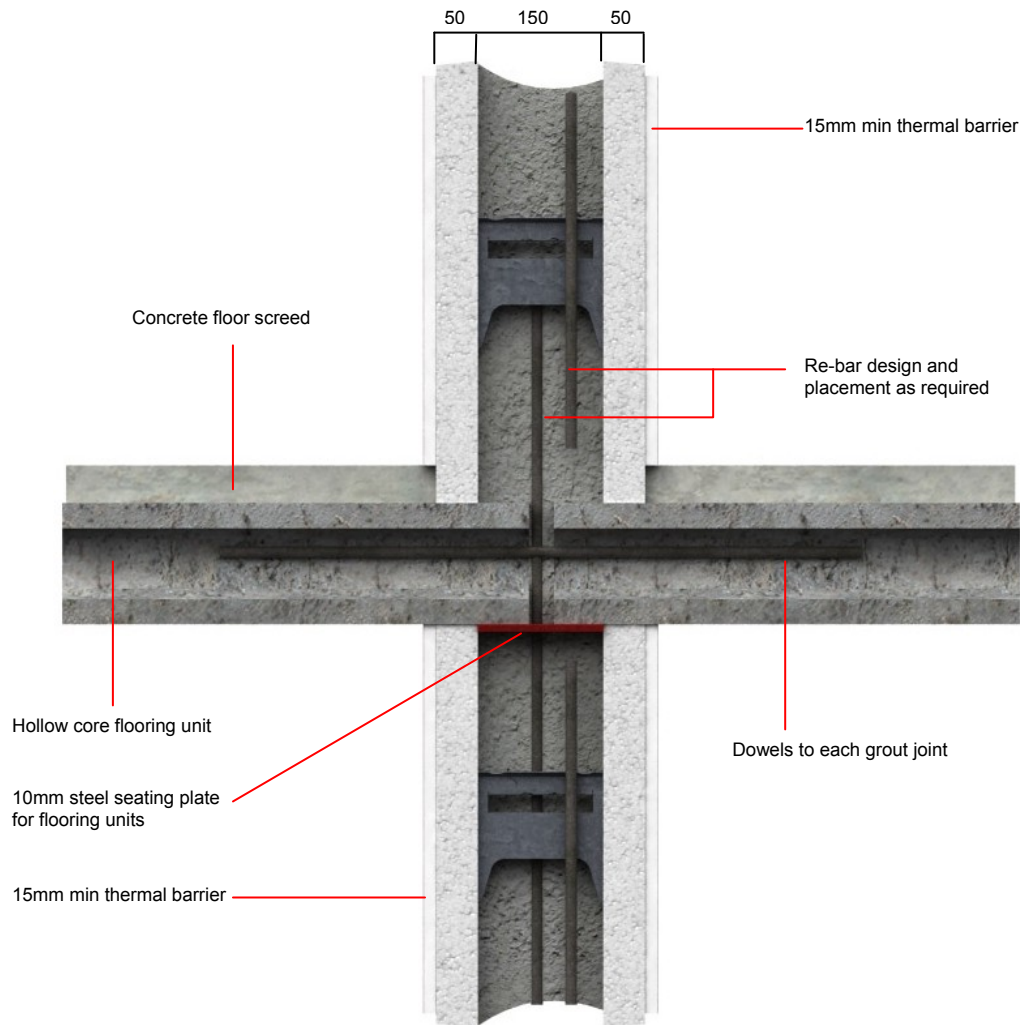

Figure 4: Precast Hollow Core Floor on 150mm Interior Wall

2.1.11 Chimney

Chimneys are not part of the Thermohouse ICF System and are not covered by this Certificate. However, the system can incorporate an NSAI Agrément approved pre-fabricated chimney system. The requirements of Clause 2.15 of TGD to Part J of the Building Regulations 1997 to 2011 require that combustible material such as polystyrene insulation have at least the following separation distance:

- 200mm from a flue, or
- 40mm from the outer surface of a brick or blockwork chimney or fireplace recess.

2.1.12 External Finish

An external render certified by NSAI Agrément for use with ICF systems is applied to the external polystyrene insulation of the Thermohouse ICF system. Alternative finishes may be used in accordance with the Thermohouse ICF installation manual. Before this can proceed the fire barriers must be fitted opposite all party walls (see Section 4.1.1). A standard external render system consists of the following:

- Fibre reinforced basecoat consisting of high polymer modified cement product, generally 6 to 8mm thick.
- Reinforcing mesh consisting of alkali resistant glass fibre mesh, 160g/m²

- Fibre reinforced second basecoat consisting of high polymer modified cement based product, generally 4 to 6mm thick (a total minimum thickness of 12mm of applied render must be achieved in all areas).
- Primer consisting of topcoat primer.
- Render Topcoat finish consisting of silicone/acrylic topcoat, available in a variety of colours and grain sizes up to 3mm.
- Ancillary items such as PVC beads, fixings and mineral wool fire stops.

2.1.13 Ancillary Items

- Anchor bolts
- ICF Connect Ltd multi hanger system
- Brickwork/stonework ties
- PVC pipe sleeves for penetrations
- Basement waterproofing membrane
- Fire stops.

2.2 MANUFACTURE

The EPS building panels are manufactured by Thermohouse Ltd. Each EPS building panel is manufactured with steel ties. Production is controlled at different stages through inspections and quality control checks.

2.3 DELIVERY, STORAGE AND MARKING

Forms are delivered to site in suitable protective packaging. All packaged components are clearly labelled with product type and production date allowing full traceability of supply. Thermohouse ICF System components should not deteriorate in normal storage conditions so long as they remain in their packaging protected from the environment and ultraviolet rays prior to use. Storage must be on firm, level and dry ground, and if the components are to be stored outside, they may be further protected from the weather by a secured covering.

Thermohouse ICF System materials should be protected from prolonged exposure to direct sunlight and must not be exposed to plastic materials containing plasticizers or to volatile aggressive solvents. The polystyrene must not come into contact with aggressive chemicals or deleterious agents e.g. diesel oil, petrol, various cleaning solvents, hydrocarbons, membranes containing coal tar pitches or building products containing solvents.

The forms are easily handled on site and may be readily cut or trimmed with a knife or fine toothed saw. Reasonable care must be taken, however, to prevent damage to forms before, during and after installation. The forms must not be punctured, split, deformed or unduly compressed before use.

2.4 INSTALLATION

2.4.1 General

Thermohouse Ltd. undertakes responsibility for the design and manufacture of the ICF system. An approved Technical Manual is available (see Section 3). Site construction is undertaken using approved installers in accordance with the Thermohouse ICF Installation Manual. Where applicable a pre-pour checklist report shall be completed before concrete pour commences into the ICF work. The external render system shall be applied by IAB registered installers of render onto ICF system in accordance with the render specification.

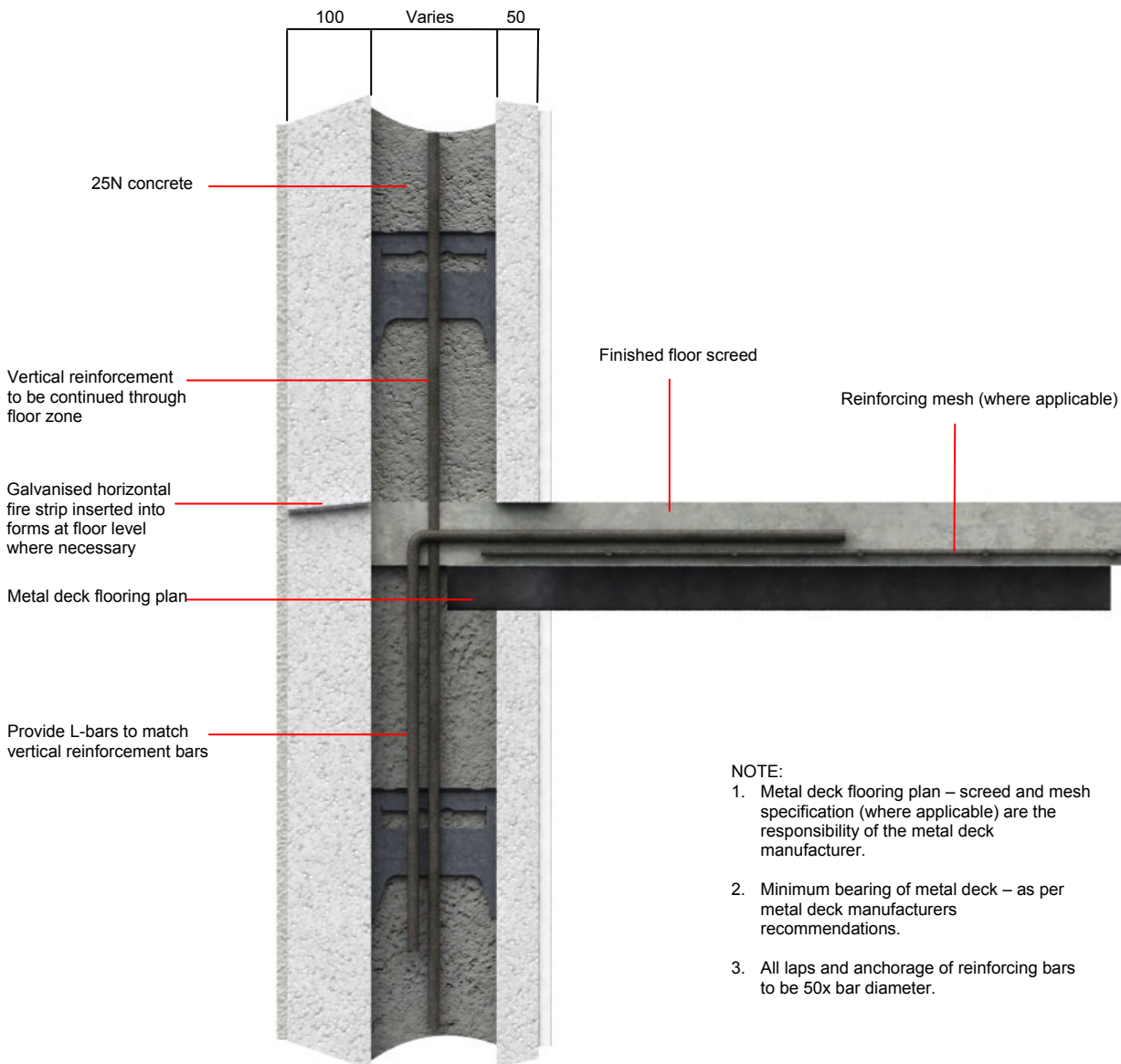

Figure 5: Typical Metal Deck Floor Detail

Concrete working best practice should be followed in both hot and cold conditions. The concrete may be placed when the air temperature is between 5°C and 30°C.

2.4.2 Foundations

Foundations are not covered by this Certificate. However, foundations and substructures must comply with the relevant clauses of BS 8004:1986 *Code of practice for foundations*, BS 8007:1987 *Code of practice for design of concrete structures for retaining aqueous liquids* and BS 8102:1990 *Code of practice for protection of structures against water from the ground as appropriate*, and must provide a flat and level footing for the shuttering, and must provide a flat and level footing for the shuttering. Any reinforcing bars cast into the substructure must be positioned such that they allow for compaction and located in the system with adequate concrete cover for protection. The foundation base from which the Thermohouse ICF System is to be built must be checked to ensure it is clean, flat and level.

2.4.3 Damp Proof Course (DPC)

Forms with appropriate materials and workmanship can produce adequately damp proof structures by using a layer of water resisting concrete, a minimum of 150mm above external ground level, in accordance with Type B structures defined in BS 8102:1990. Alternatively install a dpc e.g. brush applied liquid membrane. The external detail must be such that protection is provided up to a minimum of 150mm above the external ground level.

2.4.4 Wall Assembly

Prior to laying the first course of elements, the exact wall height required must be determined. As Thermohouse elements are 250mm high, if storey heights are not divisible by 250mm, Thermohouse height adjuster (TH10) is available in a height of 50mm and can be placed above the top course. Alternatively, the first or last course of elements can be cut horizontally.

Plan the outline of the building and the location of the door and window openings on a conventional footing or slab that is level, straight and square.

Place the end blocks on each corner, then lay the straight blocks towards the centre of each wall segment. Install the end blocks to form the closure at the location of each door. Complete installation of first course with straight blocks, cutting to length where required. Install horizontal steel reinforcement, where directed, by placing it on top of the internal webs within the block cavity.

Install the second course of blocks so that the second course is offset from the first, in a running bond pattern. At this point check for level across all of the blocks. If the courses are not level use shims or trim the block as required.

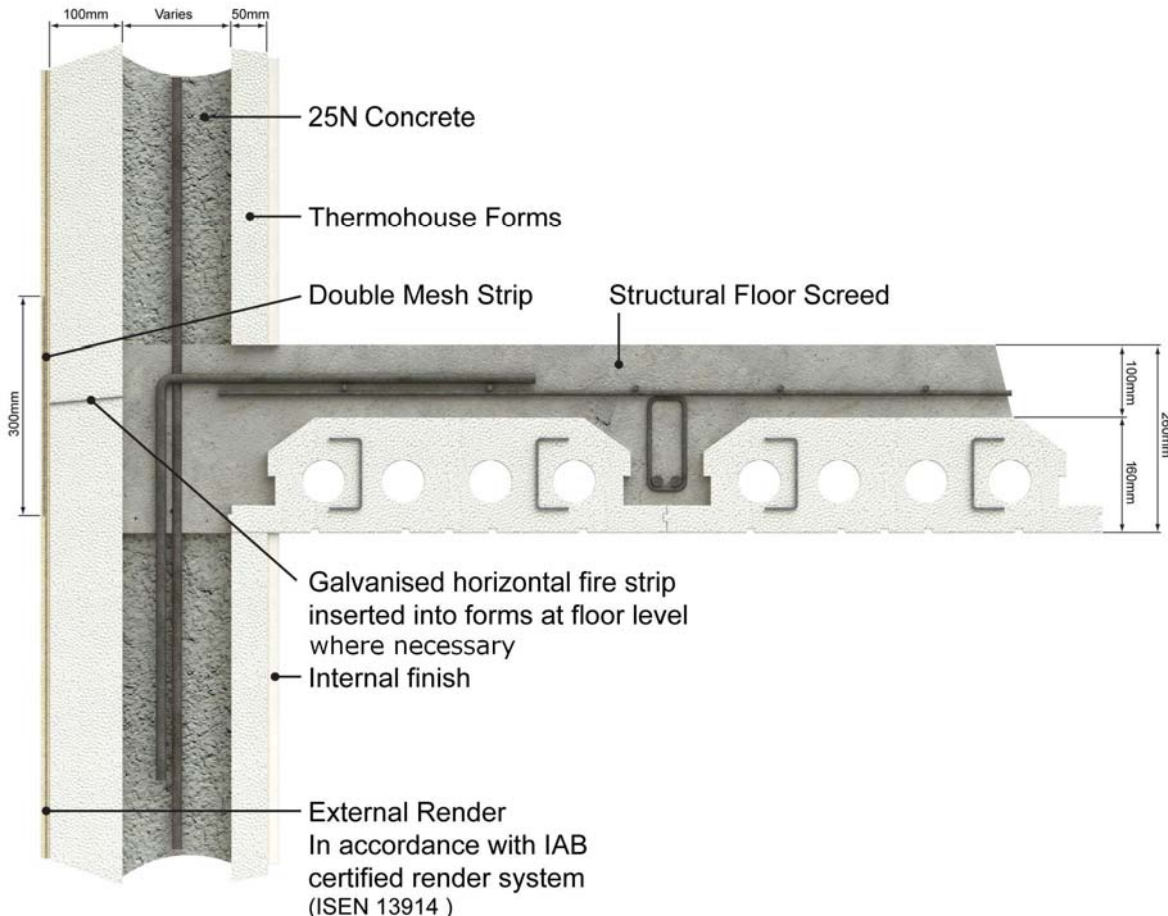

Figure 6: Section through Thermofloor 160 at External Wall

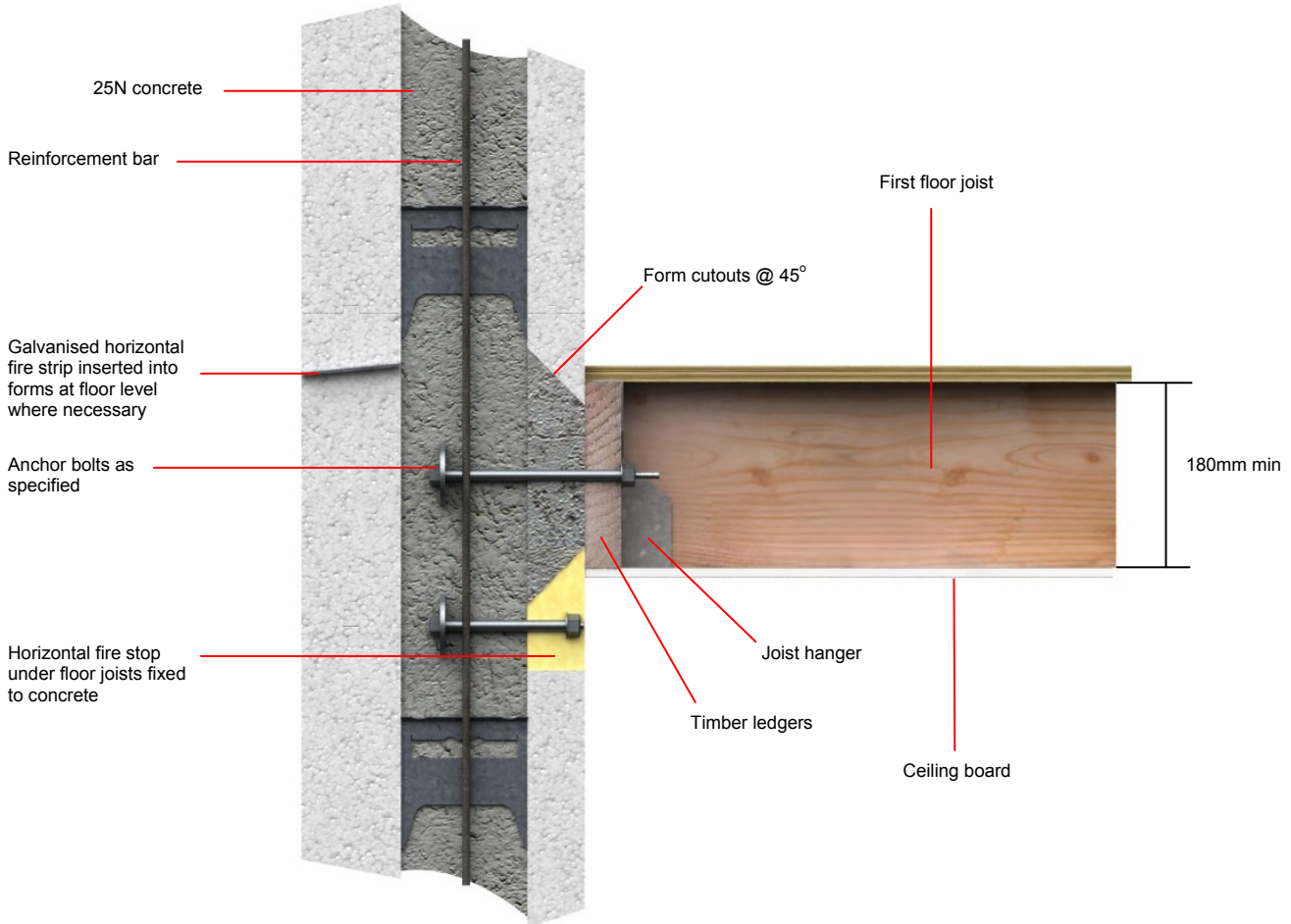

Figure 6a: Wall to Joist Details – Joist Hangers on Anchored Ledgers

Thermohouse rebated end blocks or reveal inserts must be used on the reveals at each location where external doors and windows are required, to eliminate any cold bridging.

Install additional courses of block by continuing to overlap the courses so that all joints are locked above and below by overlapping blocks.

Install alignment bracing on the inside, around the entire wall of the structure to ensure that the walls are straight and plumb and to enable alignment adjustment before and during the pour.

Place the blocks to full wall height for each storey construction. Cut the vertical reinforcing steel to length and install it from top of the wall.

Pour the concrete into the walls using a concrete pump. Start the pour into the central cavity away from the corners and not directly against the polystyrene units, allow concrete to free-flow into the corners and below window openings. The concrete should be poured in 1m lifts around the full build until full storey height is achieved. Use a slender vibrating poker (25mm) to vibrate the concrete, to remove all air pockets within the wall and to obtain full compaction of the concrete.

Screed off the concrete until it is even with the top block and install anchor bolts if necessary. These bolts can be used to install the wall plate if required. Remove bracing after the concrete has cured, and proceed with further stages of construction.

2.4.5 Reinforcement Placement

Horizontal reinforcement can be placed in different locations across the concrete fill void using the metal spacers. Horizontal reinforcing bars for lintels must be located within the lintel as specified in the structural design, the minimum length of bar being equivalent to the width of opening in the structure plus 500mm. Vertical reinforcement can then be secured to horizontal reinforcement at required centres using standard fixing methods. Bar lapping lengths as per BS 8110-1:1997 should be adopted. The system requires that in plain walls horizontal reinforcement be provided in top and bottom courses of every wall lift. The reinforcement is checked to ensure there is adequate concrete cover for protection and that compaction can take place. The horizontal and vertical reinforcement used is dia. 12mm at 1200mm centres in the wall as specified or otherwise by the engineer (see Section 3.1.1).

Heavy wall loads (such as wall units) should be supported by the concrete core and not the form tie/spacer flanges. This can be achieved by the use of timber blocks screwed or bolted into the concrete core or cast-in anchor bolts and metal plates.

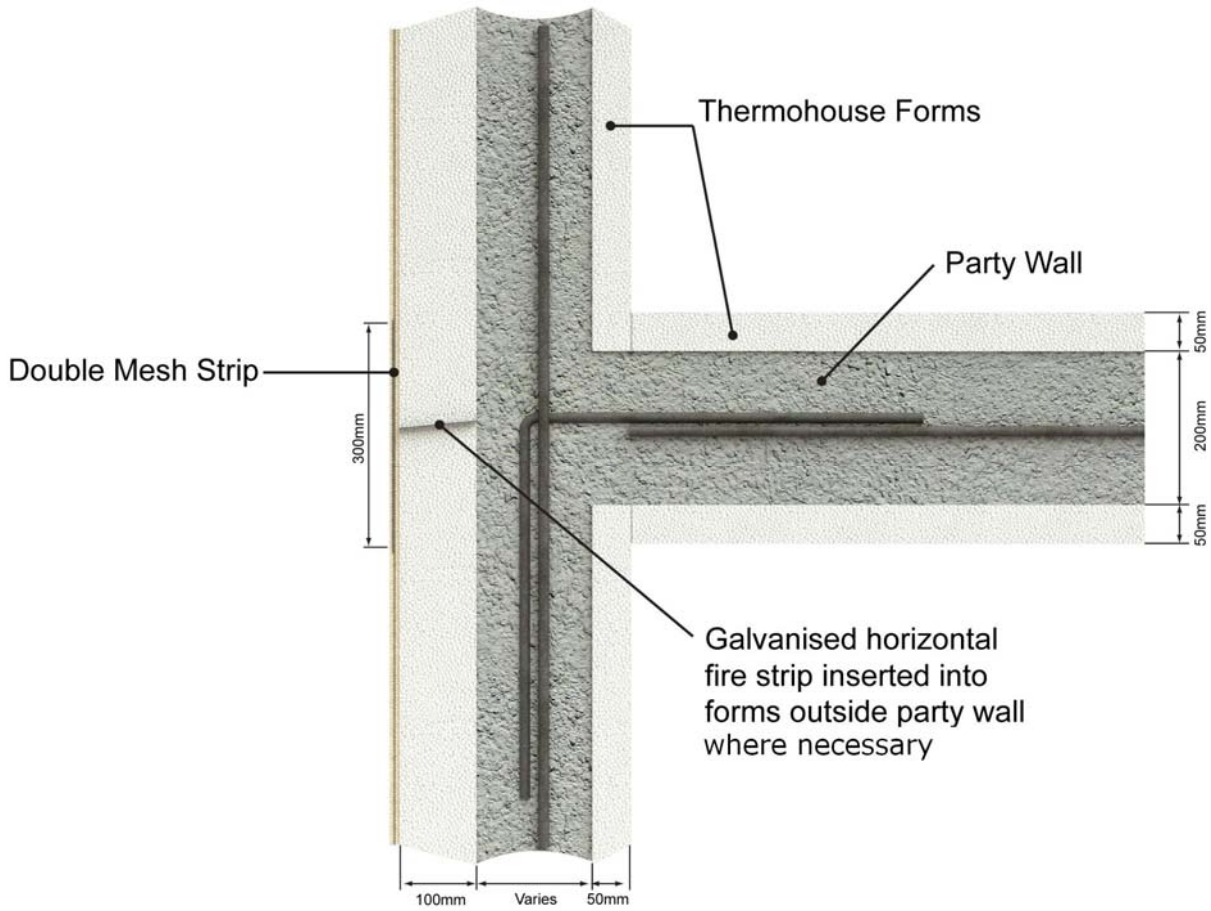

Figure 7: Typical 200mm Party Wall Detail – Plan View

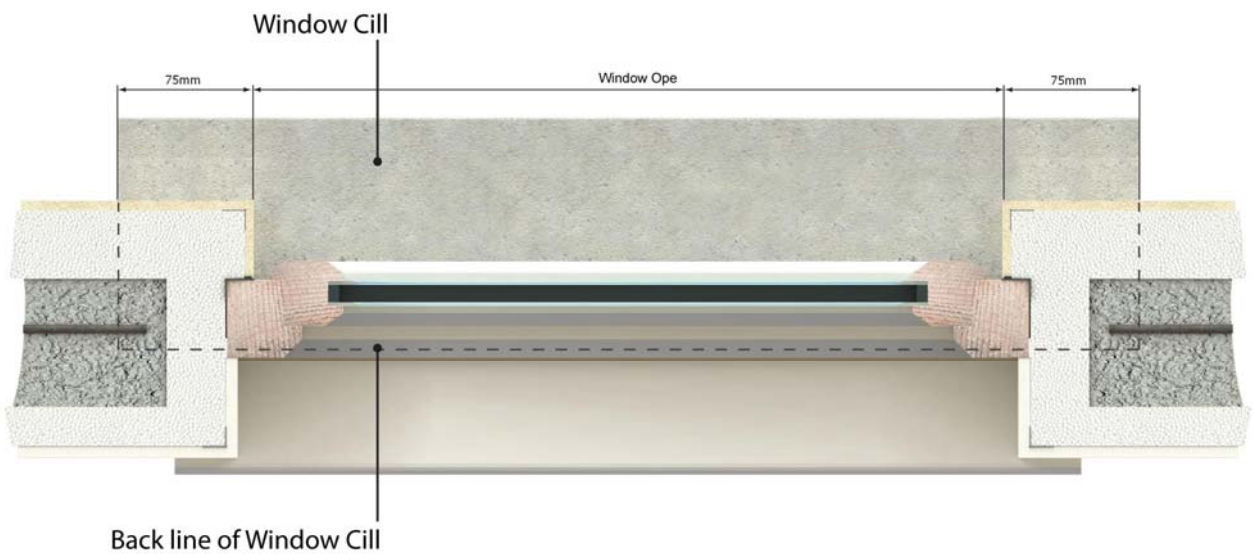
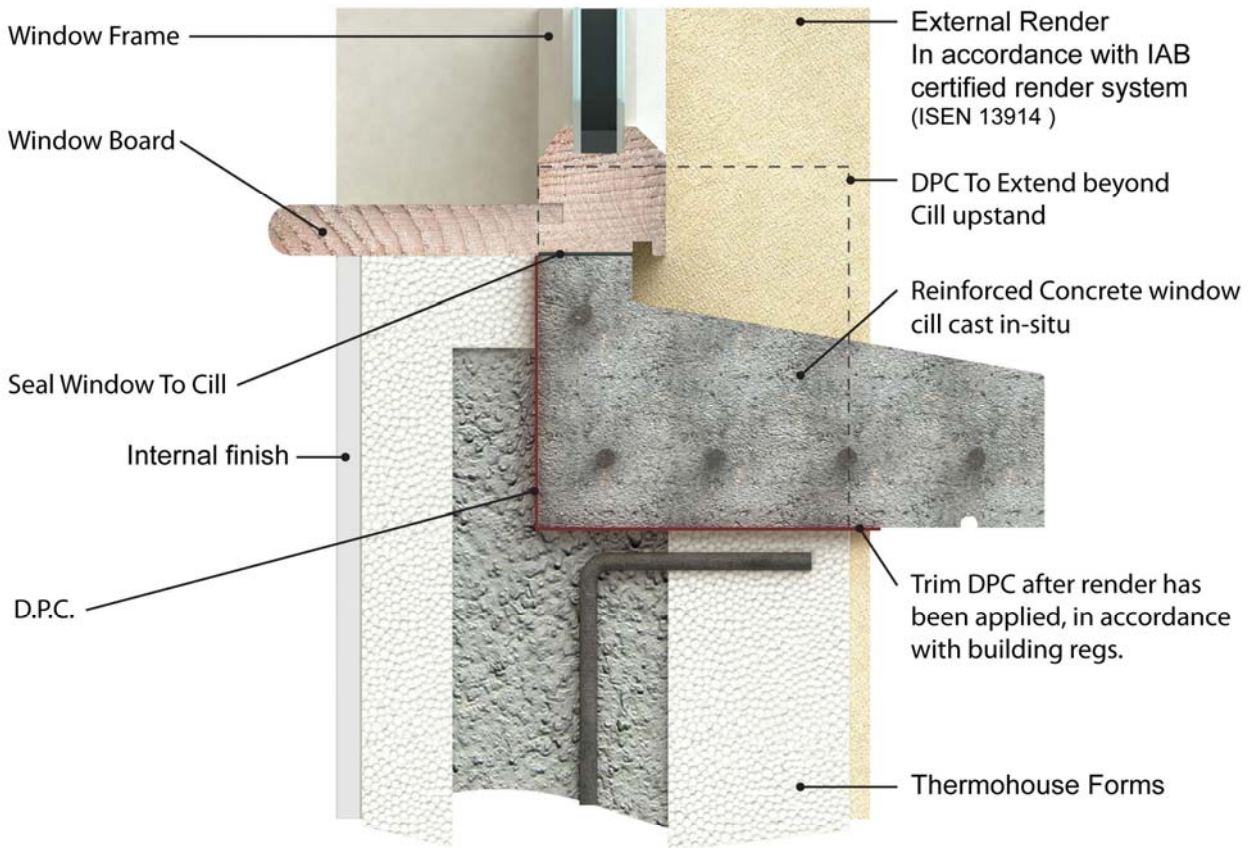

Figure 8: Concrete Window Cill Detail

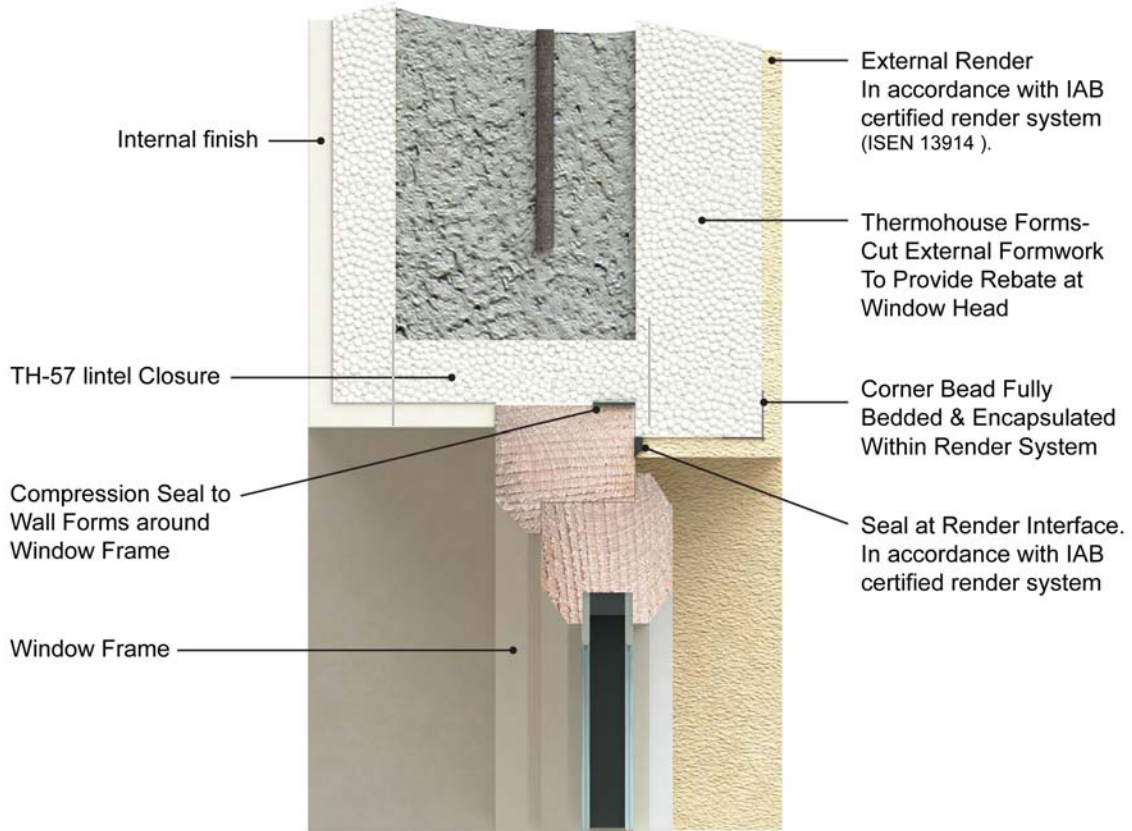

Figure 9: Window Head Detail

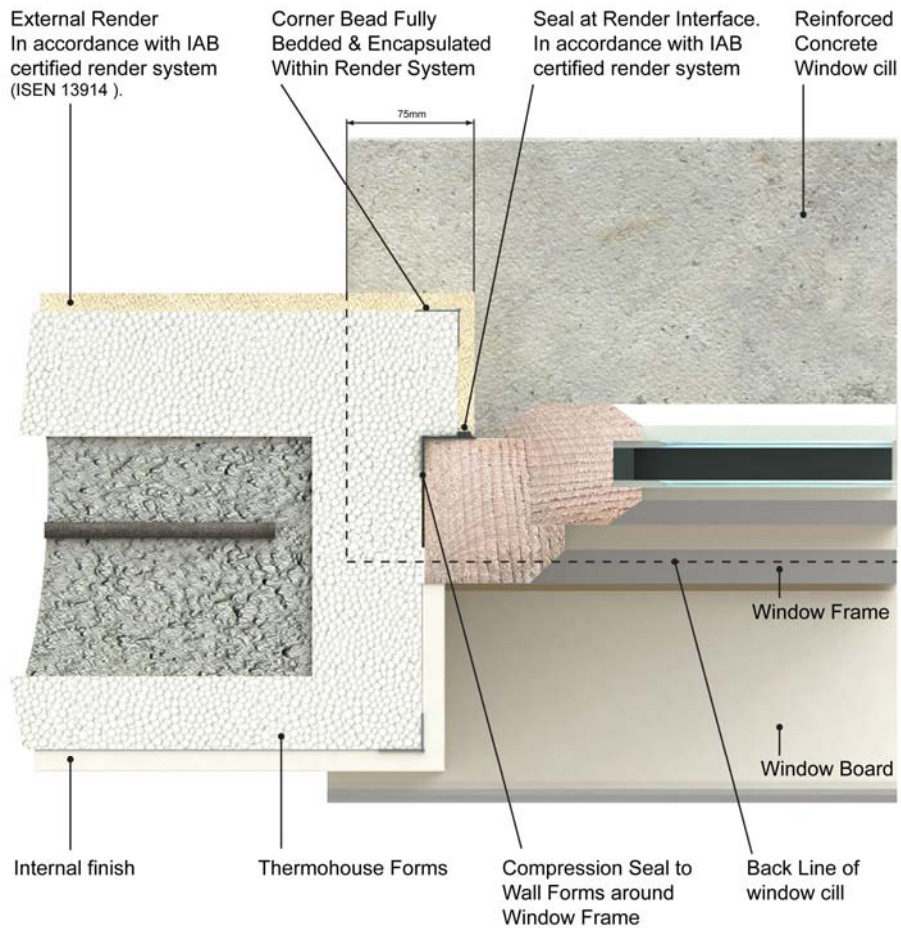

Figure 10: Detail at Window Jamb

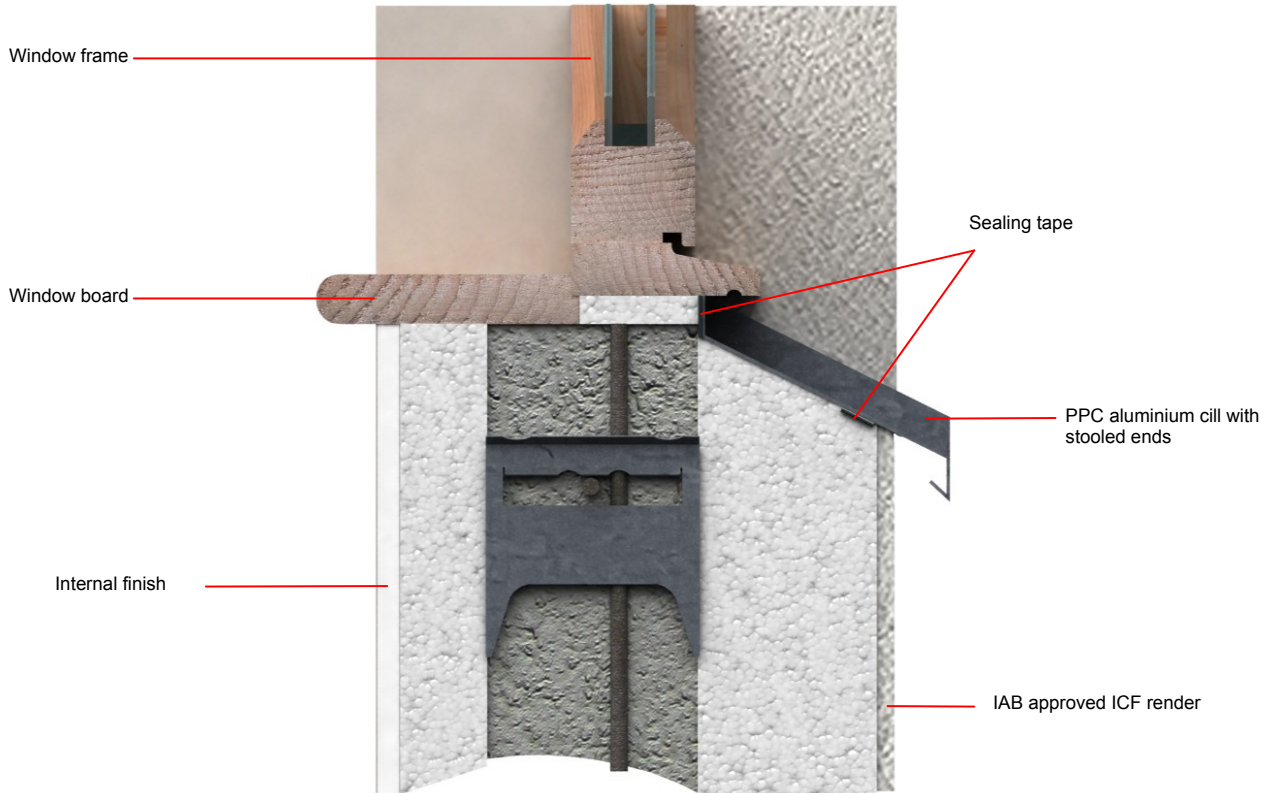

Figure 11: PPC Aluminium Window Cill Detail

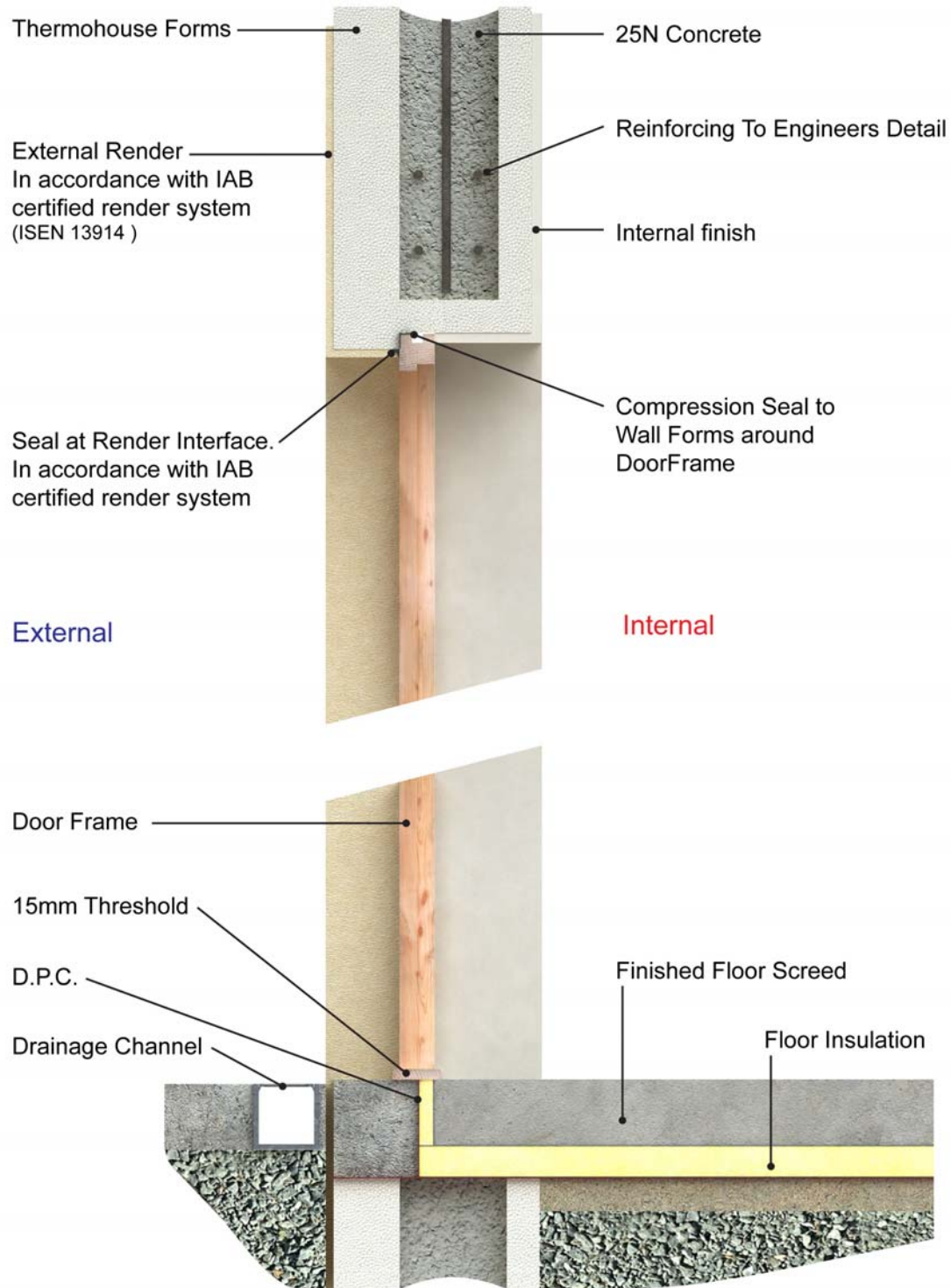

Figure 12: Section through Door Ope

2.4.6 Bracing

Install the bracing system after the second or third course has been stacked depending on the exposure of the site. Temporary bracing and propping during construction is essential to maintain alignment and adequate lateral stability during concrete filling. The installer is responsible for ensuring the adequacy of all temporary bracing. As a minimum, the full height of the assembled formwork system must be supported 700mm from corners and along the length of each wall at maximum horizontal centres of 1.2m.

All lintels must be adequately supported until the concrete has attained its minimum working strength. On exposed sites or in adverse weather conditions further support may be necessary.

Typically, the bracing and alignment systems are placed on one side of the formwork (usually the inside face) during construction, however, for very long or walls greater than one storey height, bracing on both sides may be required.

2.4.7 Openings/Services

The rigidity of the formwork is reduced by window or door openings, but is increased by the incidence of corner and crosswall details. Openings are formed during construction of the formwork. Timber headers are used as an additional bracing solution for the concrete pour. All lintels must be adequately supported until the concrete has attained its minimum working strength. On exposed sites or in adverse weather conditions further support may be necessary. Where joists are installed they must be adequately supported by the wall. The joists must not penetrate the external face of the formwork system. Locate and set items to be cast directly into concrete. Refer to Section 2.1.8 of this Certificate.

Wall openings or ducts for service penetrations can be positioned within the formwork prior to concrete pouring. At all service entry points, care must be taken to effect a properly sealed joint to prevent the ingress of vermin or moisture. Gaps in the insulation may be made good by filling and sealing with a self-expanding polyurethane foam. Service entry points to basement walls should be avoided.

Where services or flues are to penetrate the wall, a duct or sleeve through the Thermohouse ICF System should be inserted prior to placing the concrete. Electrical cables should be ducted (to avoid plasticizer migration). The cables must be placed in PVC conduit and must be sized to minimise heat build-up with resulting fire risk, in accordance with ETCI requirements (Electro-Technical Council of Ireland documents, ET 101:2000 *National rules for electrical installations*, and ET 207:2003 *Guide to the national rules for electrical installations as applicable to domestic and similar situations*).

2.4.8 Pre-Pour Checks

Once the bracing is erected, adjustments are made for plumb, alignment and level by use of the push/pull screws. Reinforcement should be checked for correct cover distance and rigidity. Before the initial pour and between concrete pours, care must be taken to remove any debris from inside the formwork. All reinforcement must be checked by engineer.

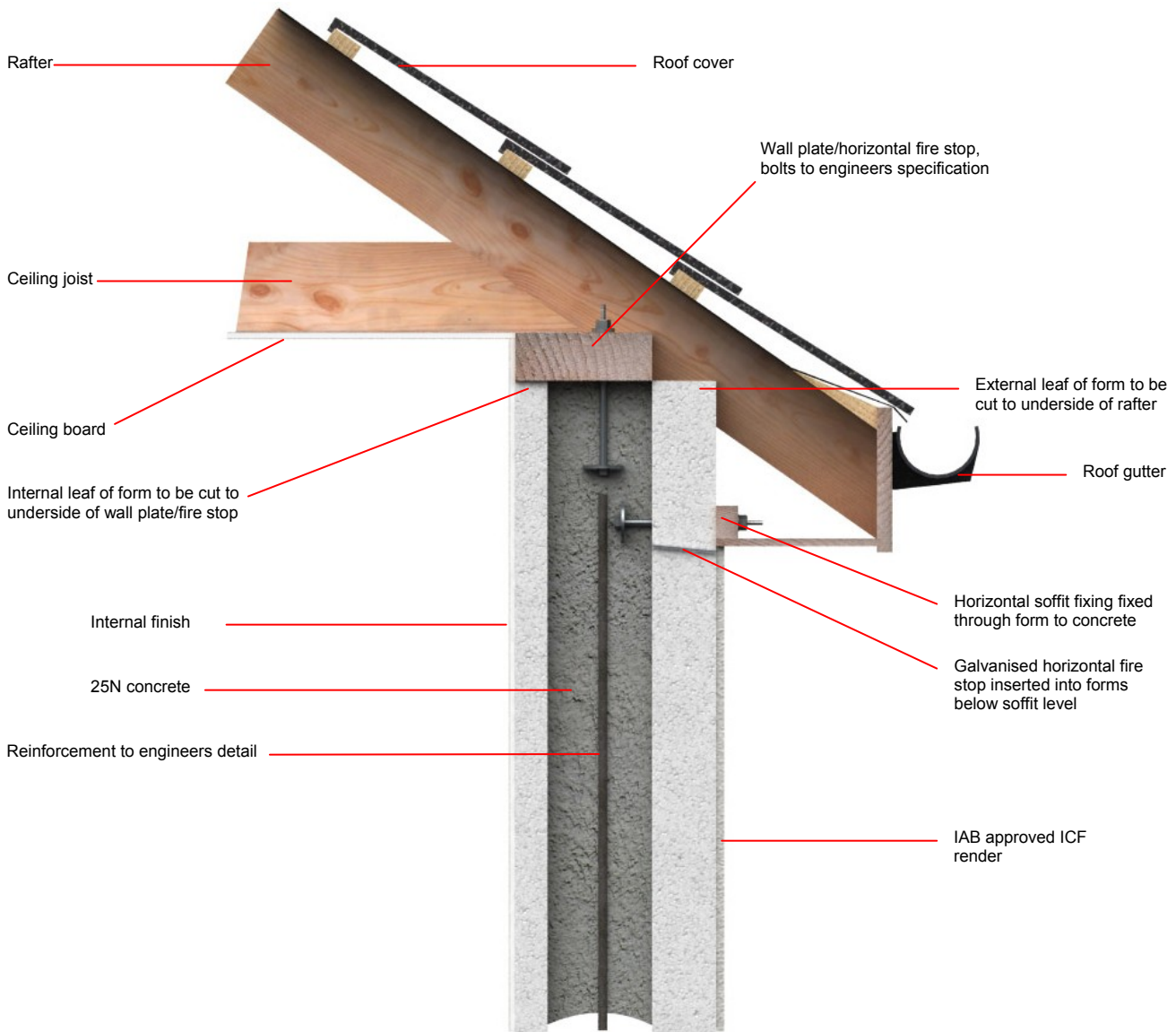

Figure 13: Wallplate Detail

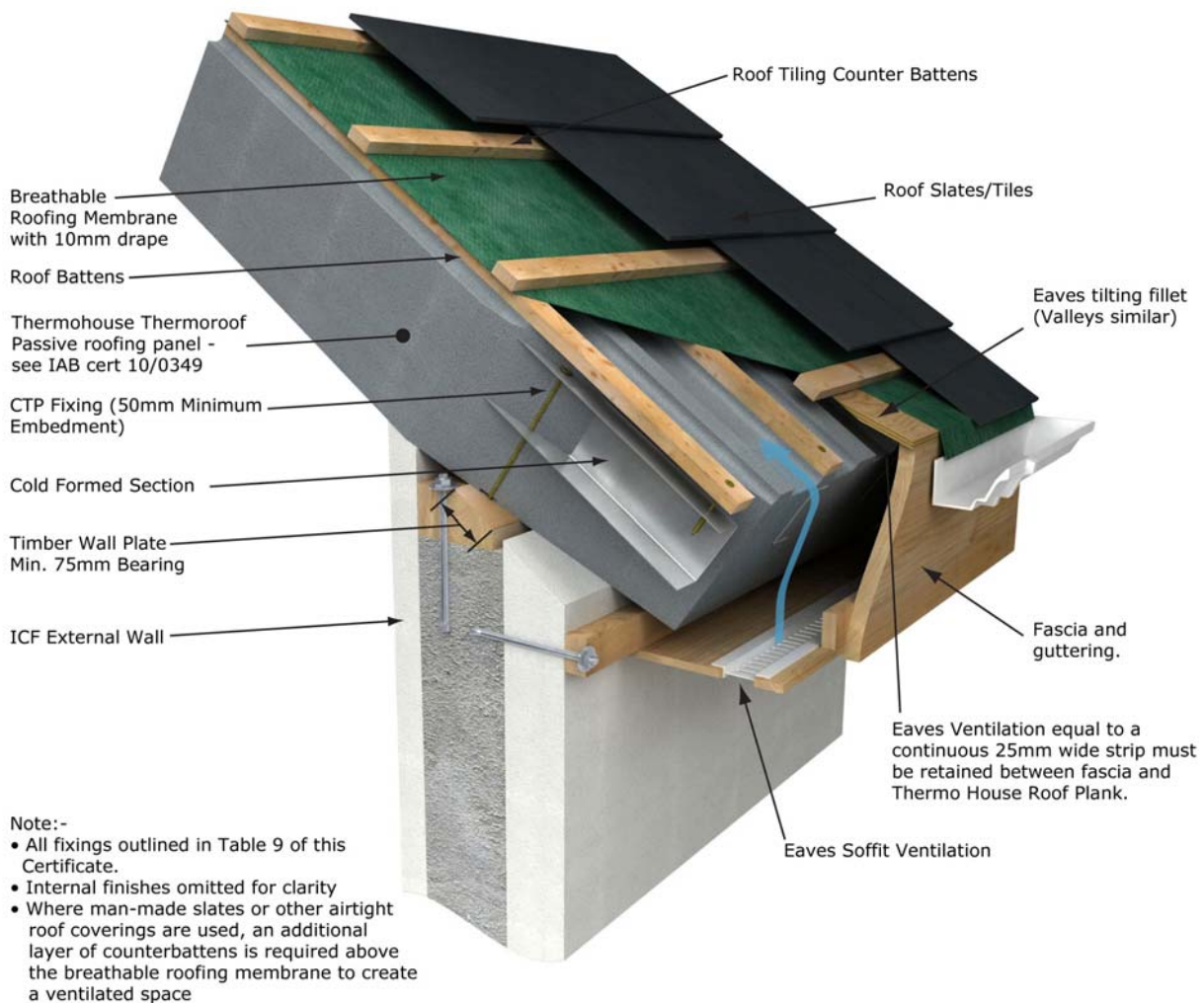

Figure 14: Eaves Detail

2.4.9 Concrete Placement

Adequate supervision and care by the installer is needed when placing concrete. Concrete can be placed using line pump or overhead boom from a concrete pump lorry. Small volumes of concrete can be placed by hand, e.g. to make up small deficiencies at the end of each pour or to the sill of window openings. The concrete should be directed into the central cavity away from corners and not directly against the polystyrene units in 1m lifts, to full storey height allowing concrete to free-flow into corners and below window openings. The first lift is allowed to stiffen before placing the second lift of concrete. Typically storey heights should be placed in three storey lifts. When forming construction joints between concrete pours, these should be located within 100mm of the top of the Thermohouse ICF System for ease of access and visual checking. Construction joints should be horizontal rather than vertical.

Lintels must be filled with concrete in a single operation, ensuring that the concrete integrates fully with the concrete in the walls at both ends. Particular attention should be paid at opening/lintel reinforcement as the steel can impede the flow of concrete around these sections. To prevent damage to the system, the use of poker vibrators above 25mm diameter is not recommended.

In very hot or freezing conditions, the top of the Thermohouse ICF System must be covered to protect the concrete from adverse curing conditions. The recommended concrete pour rate is 1000 to 1200mm/hr with a maximum of 1500mm/hr in warm temperatures.

The formwork system is filled and compacted progressively in layers not exceeding 1m lifts with a total daily concrete pour height not exceeding 3m (i.e. one storey height). This is to ensure adequate compaction is achievable and to avoid possible displacement of any reinforcement and excessive pressure being exerted on the Thermohouse ICF System.

2.4.10 Concrete Compaction

Adequate consolidation/compaction of the concrete in line with BS 8110-1:1997 is essential and the concrete must be placed so that it completely fills the Thermohouse ICF System without creating any voids. A 25mm vibrating poker should be used with care and kept back from the corners approximately 1m.

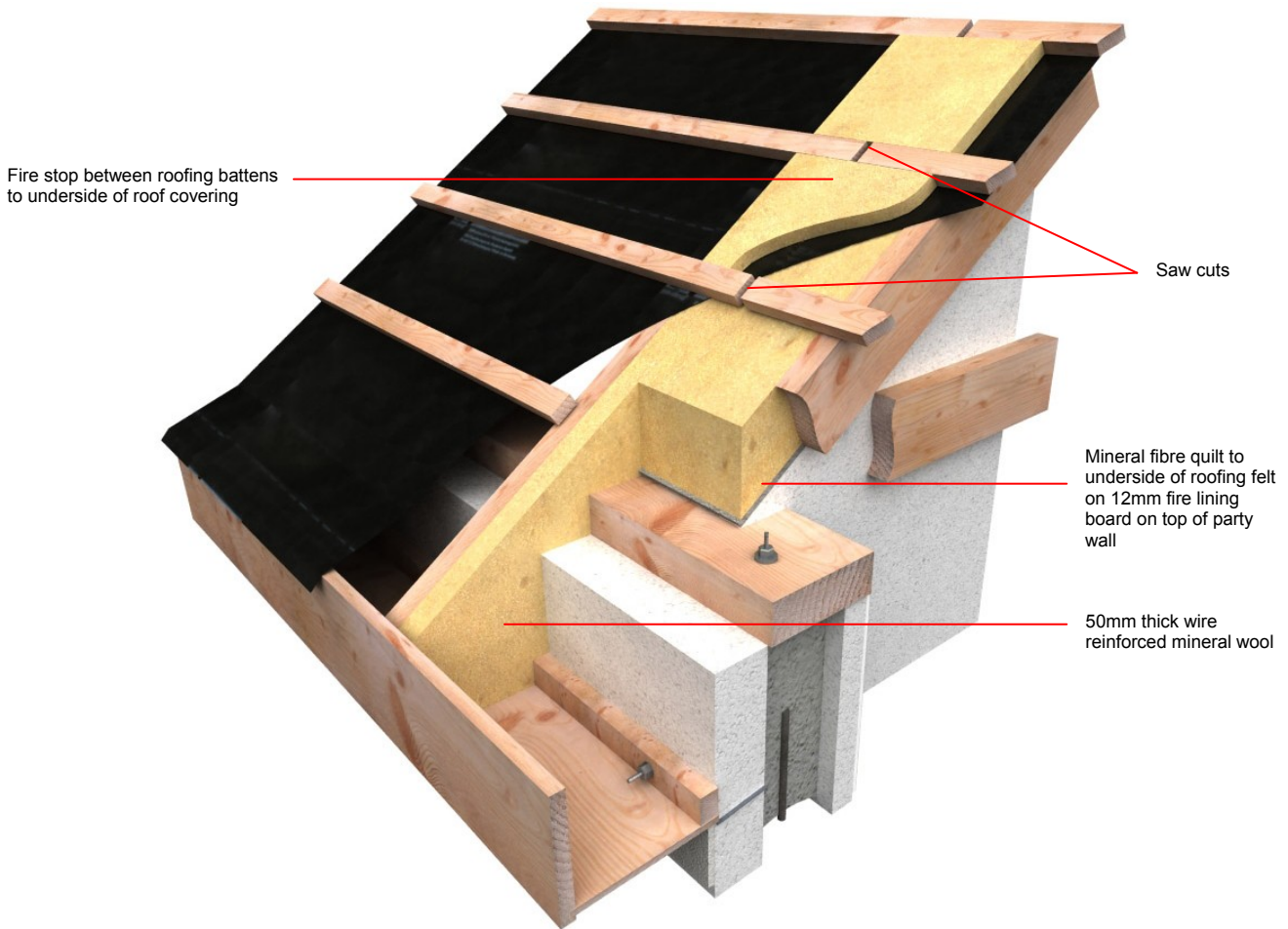

Figure 15: Fire Stopping at Party Wall

Particular attention should be given to basement walls and areas around openings. Particular attention should also be paid to the window and door openings where the steel reinforcement can impede the flow of concrete beneath these sections. Concrete in lintels must be mechanically tamped or vibrated to ensure proper compaction around any steel reinforcement.

For unreinforced walls, correct placement and specification of the concrete together with hand tamping or rodding is adequate. Where reinforcement is present for structural purposes, mechanical vibration is essential with internal poker vibrators smaller than 25mm diameter. Special care is required to avoid touching the formwork when using this equipment. Where internal poker vibrators are used, these should be confined to the central concrete core between reinforcement layers and used in accordance with the certificate holder's instructions.

The formation of construction joints between concrete pours should be located as close to the top of the form wherever possible for the formwork wall to enable visual checking and ease of access for the formation of these joints. The construction joints formed should be horizontal rather than vertical.

The completeness of filling of the formwork can be easily confirmed by tapping its surface (with the palm of the hand or a wooden mallet) – any voids will be detected by a distinctive hollow sound. This should be done as the

concrete is placed so that any voids detected can be easily corrected. The compaction of the concrete can be confirmed by tapping the surface as described up to 2.8m high walls. For load bearing walls above this height, the EPS can be removed to inspect the concrete core or alternatively, normal concrete cores can be taken as required.

2.4.11 Post-Pour Tasks

After pouring is complete, immediately check the walls are straight and vertical adjusting the bracing support as required.

Any damage to the forms should be repaired immediately and any concrete spillage or leakage of grout may be removed by hosing down the exposed face of the system before it sets.

The concrete in the Thermohouse ICF System must be left to cure until it has achieved a specified minimum strength, usually after two or three days, for construction to continue. Structural fixings should not be loaded until the concrete has achieved a sufficient strength, and supports should be left in place as long as required.

Where lateral bracing walls and other structures are intended to act in concert with the concrete filled forms, the polystyrene face must be removed to allow the required structural connection between the concrete core and the supplementary structure.

Backfilling around bottom layers of formwork to the ground floor walls should not take place until the concrete has reached sufficient design strength i.e. a minimum period of seven days.

Any damage to the faces of the Thermohouse ICF System should be made good prior to the application of the internal and external finishes.

Electrical and plumbing services can be fixed within the formwork or onto the concrete core by cutting chases into the EPS using a router or hot knife. Where chases are made in the polystyrene they should be kept to a minimum and need to be located at appropriate distances from separating walls.

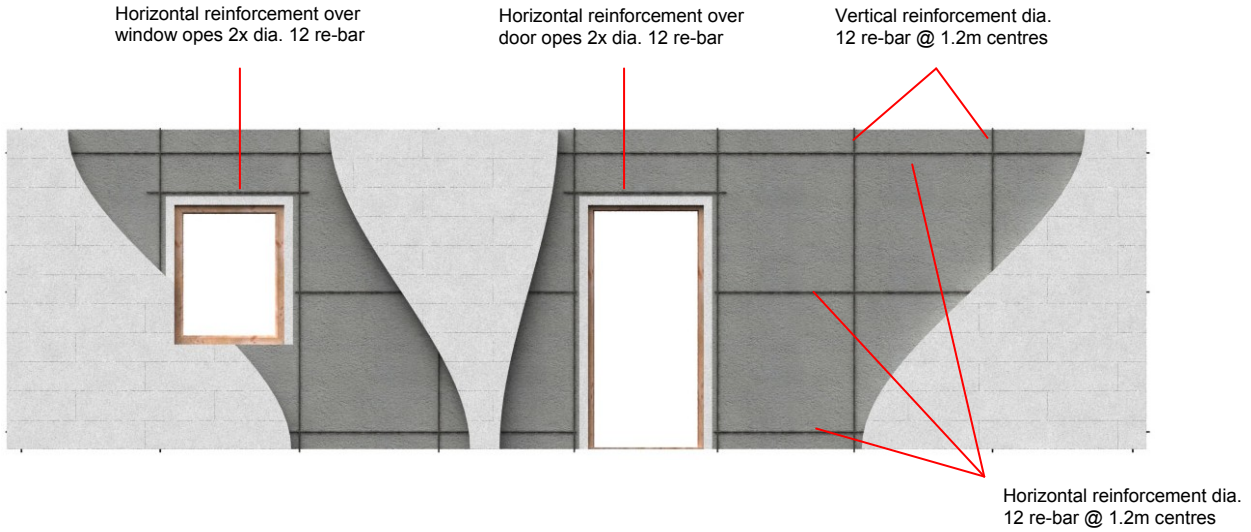

Figure 16: Minimum Necessary Reinforcing Steel

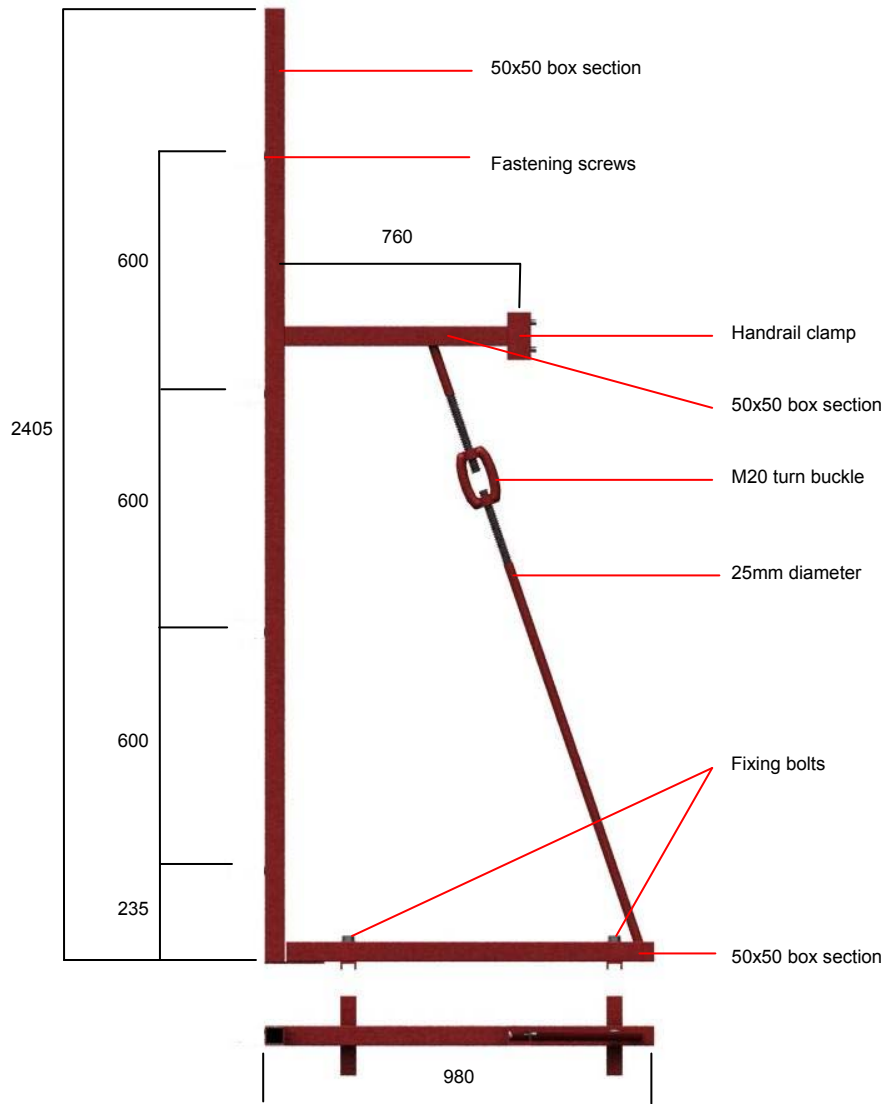

Figure 17: Wall Support & Scaffold Frame Support Details

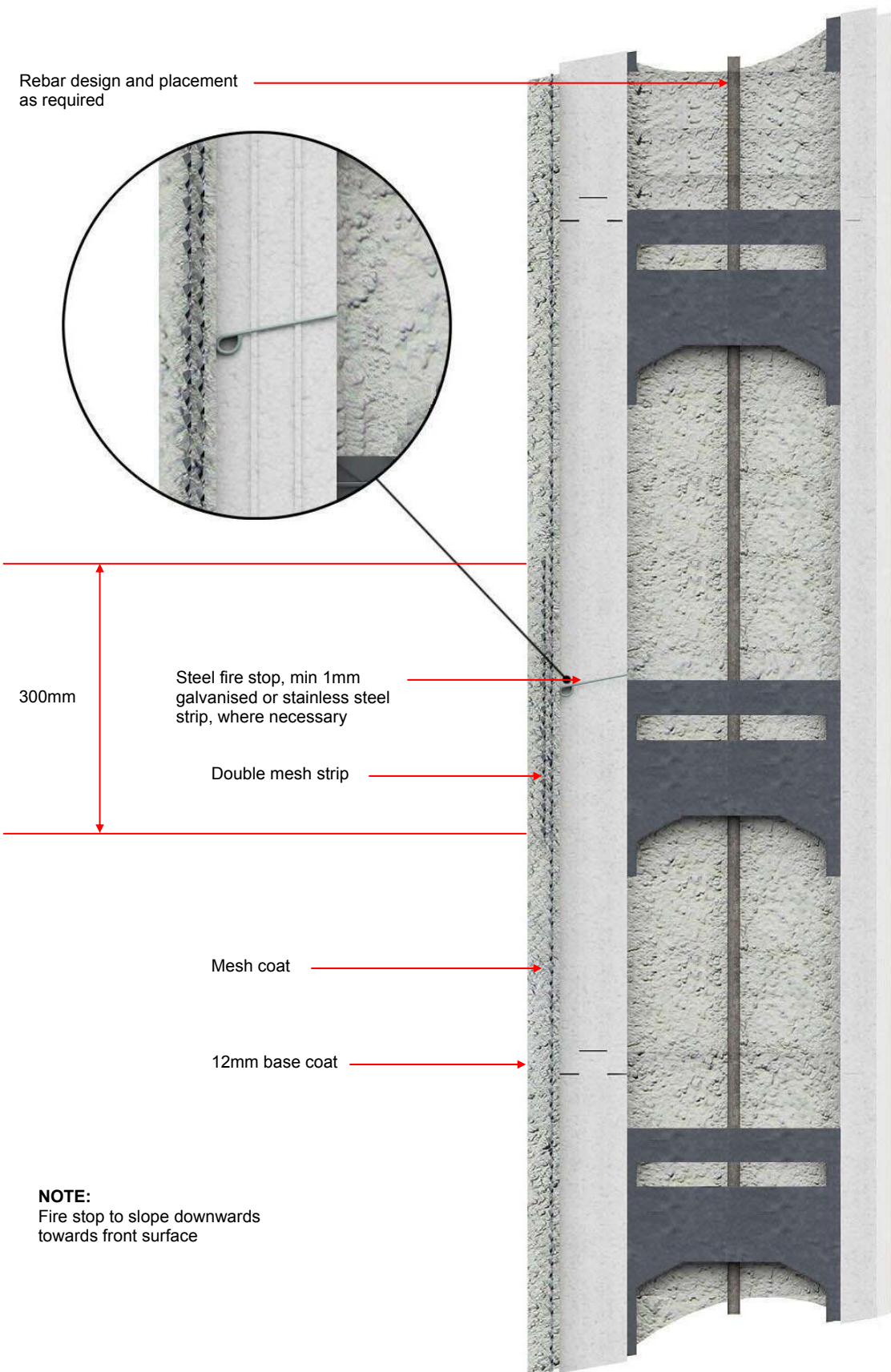

Figure 18: Fire Stop Detail

3.1 STRENGTH & STABILITY

3.1.1 General

The Thermohouse ICF System is intended for use where Architect's drawings are available and satisfy the Building Regulations 1997 to 2011 – the Architect and Engineer design team of the developer are responsible for the architectural drawings and overall building design to comply with the Building Regulations.

Buildings constructed using the Thermohouse ICF System shall be certified by a competent, chartered civil or structural engineer, with experience in design of buildings and structures incorporating the Thermohouse ICF System, as being in accordance with Part A of the Building Regulations 1997 to 2011.

3.1.2 Loading

The vertical imposed loads should not exceed the following:

Element	Loading	
Roof	Distributed Load	0.75kN/m ²
Floor	Distributed Load	1.50kN/m ²
Ceiling	Distributed Load	0.75kN/m ²

Table 2: Vertical Imposed Loads

The vertical dead loads should be calculated based on the self weight of materials to be used in construction, and reference should be made to BS 648:1964 *Schedule of weights of building materials* in this regard.

Designs for typical dwellings which have been completed have been examined by NSAI Agrément and comply with the following standards:

- BS 6399-1:1996 *Loading for buildings – Code of practice for dead and imposed loads*
- BS 6399-2:1997 *Loading for buildings – Code of practice for wind loads*
- BS 8200:1985 *Code of practice for the design of non-load bearing external vertical enclosures of buildings*

Reinforcement for intel load spans and spacings of anchor bolts must be as per the Thermohouse ICF Technical Manual.

Design snow and wind loads must be based on Diagram 14 and 15 of TGD to Part A of the Building Regulations 1997 to 2011. The maximum characteristic wind loading pressure for the Thermohouse ICF System has been calculated as 1.3kN/m², in accordance with BS 6399-2:1997.

Where timber elements are used they are designed in accordance with IS 444:1998 *The use of structural timber in buildings*, ENV 1955-1-1 *Design of timber structures – General rules and rules for buildings* and ENV 1955-1-2 *Design of timber structures – General rules for fire design*.

Panel designs are based on the wind exposure map provided in the TGD to Part A of the Building Regulations 1997 to 2011. For very exposed sites on hills above the general level of the surrounding terrain, the system can be specifically designed to withstand the unusually high wind loading. This is likely to involve the provision of additional ground anchorage and increased lateral bracing, both of which can be readily provided in the system.

3.1.3 Retained Earth

Differences in the final level of ground or floor slabs between one side of a wall and the other should not exceed four times the wall thickness unless designed by an Engineer, e.g. in basement construction using the 350mm Thermohouse element.

3.1.4 Stability

Because of the homogenous and boxed nature of the form of construction, domestic structures built using the Thermohouse ICF System will be stable in themselves. Normally the elements requiring particular care are the tying in of floors and roofs into walls and the bracing of any free standing or unbutressed sections of wall.

3.1.5 Impact Resistance

The Thermohouse ICF System provides a robust system that has a high resistance to hard and soft body impacts likely to be associated with normal use situations. The rendered wall is acceptable for all normal situations and is classed as Category 1, which is described in ETAG 004:2000 *External thermal insulation composite systems with rendering* as zone readily accessible at ground level to the public and vulnerable to hard body impacts but not subjected to abnormally rough use.

3.2 STRUCTURAL FIRE SAFETY

3.2.1 Internal Fire Spread (Linings)

The NSAI Agrément approved internal plaster finish for ICF systems and plasterboard slabs used on the internal finish are non-combustible and have a Class 0 'spread of flame' rating. Surface spread of flame rating of the finished construction will be determined by the surface spread of flame rating of the lining materials used.

3.2.2 Internal Fire Spread (Structure)

When the building has been designed and installed in accordance with the requirements of this certificate, the walls are capable of withstanding the effects of fire for 60 minutes without loss of stability.

3.2.3 External fire spread

The NSAI Agrément certified renders for use with ICF Systems have a spread of flame rating equivalent to Class 0 on both faces. In respect of 'Spread of Flame', this is the highest performance classification set out in the Building Regulations 1997 to 2011.

3.3 WEATHERTIGHTNESS

Externally the walls are protected by an approved render. A DPC/radon barrier is installed at ground level to prevent rising damp. A DPC is also used around

window sills, and a double seal is used at window reveals. In the case of aluminium window cills, they shall be provided with stop ends. In the case of concrete cills, they shall either be stooled or be 75mm wider than window ope and be provided with a wraparound DPC.

4.1 BEHAVIOUR IN RELATION TO FIRE

The fire resistance of load bearing wall, compartment wall and floor elements of the Thermohouse ICF System in two storey construction (not more than 7m in height) is 60 minutes. Based on Table 4 of BS 8110-2:1985 *Structural use of concrete – Code of practice for special circumstances*, and Thermohouse ICF 150mm wall has over 60 minutes fire performance. Minimum cover to reinforcement is 30mm (for durability), which exceeds the required cover of 25mm for fire protection.

Escape stairways constructed using the Thermohouse ICF System must be lined with fire retardant linings.

The concrete in the walls has a Class 0 rating and is non-combustible as per Tables A6 and A8 of TGD to Part B of the Building Regulations 1997 to 2011. The polystyrene used in the wall and floor panels is flame retardant.

External walls with the IAB approved external render for ICF systems applied have been tested as Class 1 as per BS 476-7:1997 *Fire tests on building materials and structures – Method of test to determine the classification of the surface spread of flame of products*. In the case of the internal wall, as the design is for the use of 12.5mm gypsum plasterboard slabs nail or screw fixed to timber battens fixed to the concrete core, the internal walls have a Class 0 rating and are acceptable for all areas according to the general provisions of Clause 2.1 of Section B2 of TGD to Part B of the Building Regulations 1997 to 2011.

4.1.1 Fire Barriers

There are no cavities in the walls. However, as the Thermohouse ICF System has polystyrene, it must be fire stopped opposite every compartment wall. The external render fire stops the insulation around the window and door openings. In the case of timber floors, a fire barrier must be provided at the top of plasterboard slabs. The location of fire barriers should be agreed with the Architect.

Fire stops are created by placing strips of galvanised steel 1mm thick (weight 2.68kg/m²) to the full depth of the expanded polystyrene, installed as shown in Figure 18 or as described in Section 3.3.4 of TGD to Part B of the Building Regulations 1997 to 2011. The fire stop must be placed level with any internal ceiling plasterboard at every floor level from the 2nd storey up. A strip of mesh reinforcement is placed along the length of the fire stop before a second layer of mesh reinforcement is placed over the entire wall.

4.1.2 Toxicity

The system is non-toxic in normal conditions. In fire conditions, the polystyrene will begin to soften, to contract and finally melt above 100°C. Ignition occurs between 350°C and 450°C. The mass of material present is low and hence the amount of heat released is low. When burning, EPS behaves like other hydrocarbons such as wood and paper. The products of

combustion are basically carbon monoxide and styrene: during a fire, the styrene may be further decomposed, giving off oxides of carbon, water and a certain amount of smoke. The polystyrene used in the Thermohouse ICF System is flame retarded.

4.1.3 Security of Fixings

With regard to security of fixings, there is the mechanical fire fixing for the Thermohouse ICF System of one per m² above two storeys. Also the mechanical fixings for the fire stopping are austenitic stainless steel. Eject supplementary polypropylene fasteners are also used whenever necessary to fix insulation to the wall.

4.2 THERMAL INSULATION AND U-VALUES

The thermal conductivity, λ , value of the Thermohouse ICF wall is 0.035W/mK for standard white EPS and 0.030W/mK for graphite-enhanced grey EPS. The calculated U-value for the Thermohouse ICF wall system varies from 0.23 to 0.10W/m²K depending on the thickness and type of EPS used in the particular wall. Check with manufacturer for details.

The linear thermal transmittance (ψ) or Psi describes the heat loss associated with junctions and around openings. The Thermohouse ICF System has been assessed and when detailed in accordance with this Certificate, these thermally bridged junctions can be compared with the requirements of Table D1 of Appendix D of TGD to Part L of the Building Regulations 1997 to 2011. ' ψ ' values for bridged junctions as outlined in Table 3 can be used for calculating the 'y' factor for a dwelling.

' ψ ' values for other junctions outside the scope of this Certificate should be assessed in accordance with the BRE IP1/06 "Assessing the effects of thermal bridging at junctions and around openings" and BRE Report BR 497 "Conventions for calculating linear thermal transmittance and temperature factors" in accordance with Appendix D of TGD to Part L of the Building Regulations 1997 to 2011.

4.3 CONDENSATION

The system was subjected to a condensation risk analysis, which concluded that the risk of surface and interstitial condensation is minimal and that no vapour barrier is required.

4.4 SOUND

The party wall requirement is met by the wall thickness of the Thermohouse 200mm wall which gives 490kg/m². This satisfies the requirement of 415kg/m² of Diagram 5 of TGD to Part E of the Building Regulations 1997 to 2011. With regard to compartment floors in apartments, the minimum required mass for hollowcore type floors with a screed and soft covering is 365kg/m² as per Diagram 10 of TGD to Part E.

4.5 DURABILITY

Buildings based on the Thermohouse ICF System, when rendered using the NSAI Agrément certified renders,

subject to maintenance, when constructed in accordance with the manufacturer's instructions and this Certificate, will have a minimum design life of at least 60 years in accordance with BS 7543: 1992 *Guide to Durability of Building Elements, products and components*.

4.6 MAINTENANCE

The rendering/concrete in the wall panels is maintenance free – however, the coloured rendering may discolour with time. It is considered that period re-coating of the silicone/acrylic top coat may be necessary every 18/20 years to improve the appearance. The external sealants around window and door frames should be inspected periodically and replaced when necessary.

4.7 PRACTICABILITY

A Technical/Installation Manual incorporating Health & Safety guidelines are provided by Thermohouse Ltd. Erection of the Thermohouse ICF System must be by approved trained installers.

4.8 TESTS AND ASSESSMENTS WERE CARRIED OUT TO DETERMINE THE FOLLOWING:

- Structural strength and stability
- Behaviour in fire
- Resistance to airborne and impact sound transmission
- Thermal transmittance values
- Condensation risks for external walls
- Impact resistance for external walls
- Site erection controls

4.9 OTHER INVESTIGATIONS

- The manufacturing process was examined including the methods adopted for quality control, and details were obtained of the quality and composition of the materials used
- Site visits were conducted to assess the practicability of installation
- Bought-in components were assessed for suitability for use
- No failures of the product in use have been reported to NSAI Agrément.

Target linear thermal transmittance (ψ) for different types of junctions.		Temperature Factor	TGP L Default Ψ -value (W/m.K)	Thermo House ICF Ψ -value (W/m.K)
Figure	Junction detail in external wall	Min = 0.75	(W/m.K)	(W/m.K)
10	Window/ Door Lintels	0.95	0.30	0.02
9	Sill - Aluminium	0.80	0.04	0.07
8	Sill - Concrete	0.77	0.04	0.24
11	Jamb	0.95	0.05	0.02
1	Ground floor - strip foundation	0.93	0.16	-0.04
2	Ground floor - raft foundation	0.93	0.16	0.06
3	Intermediate Concrete floor within a dwelling †	0.88	0.07	0.24
	Intermediate Concrete floor within a dwelling	>0.88	0.07	0.09
6	Intermediate timber floor within a dwelling †	0.91	0.07	0.14
	Intermediate timber floor within a dwelling	>0.91	0.07	0.04
13	Eaves: insulation at ceiling level		0.06	
14	Eaves: insulation between and below rafter level		0.04	
	Gable: insulation at ceiling level		0.24	
	Gable: insulation between and below rafter level		0.04	
	Corner: normal	0.94	0.09	0.06
	Corner: inverted		-0.09	
	Internal ICF partition wall	0.96	N/A	0.03
	Internal stud partition wall		N/A	
	200mm Party wall between dwellings*	>0.95	0.06	0.06
7	200mm Party wall between dwellings* †	0.95	0.06	0.12

* For these junctions half of the Ψ -value is applied to each dwelling.

† For these junctions the ψ -value includes the effects of the continuous 1mm galvanised steel strip fire stop.

Ψ -value for additional and improved junctions are available from the manufacturer.

Table 3: Linear thermal transmittance (ψ)

5.1 National Standards Authority of Ireland ("NSAI") following consultation with the Irish Agrément Board ("IAB") has assessed the performance and method of installation of the product/process and the quality of the materials used in its manufacture and certifies the product/process to be fit for the use for which it is certified provided that it is manufactured, installed, used and maintained in accordance with the descriptions and specifications set out in this Certificate and in accordance with the manufacturer's instructions and usual trade practice. This Certificate shall remain valid for five years from date of issue so long as:

- (a) the specification of the product is unchanged.
- (b) the Building Regulations 1997 to 2011 and any other regulation or standard applicable to the product/process, its use or installation remains unchanged.
- (c) the product continues to be assessed for the quality of its manufacture and marking by NSAI.
- (d) no new information becomes available which in the opinion of the NSAI, would preclude the granting of the Certificate.
- (e) the product or process continues to be manufactured, installed, used and maintained in accordance with the description, specifications and safety recommendations set out in this certificate.
- (f) the registration and/or surveillance fees due to IAB are paid.

5.2 The IAB mark and certification number may only be used on or in relation to product/processes in respect of which a valid Certificate exists. If the Certificate becomes invalid the Certificate holder must not use the IAB mark and certification number, and must remove them from the products already marked.

5.3 In granting Certification, the NSAI makes no representation as to;

- (a) the absence or presence of patent rights subsisting in the product/process; or
- (b) the legal right of the Certificate holder to market, install or maintain the product/process; or
- (c) whether individual products have been manufactured or installed by the Certificate holder in accordance with the descriptions and specifications set out in this Certificate.

5.4 This Certificate does not comprise installation instructions and does not replace the manufacturer's directions or any professional or trade advice relating to use and installation which may be appropriate.

5.5 Any recommendations contained in this Certificate relating to the safe use of the certified product/process

are preconditions to the validity of the Certificate. However the NSAI does not certify that the manufacture or installation of the certified product or process in accordance with the descriptions and specifications set out in this Certificate will satisfy the requirements of the Safety, Health and Welfare at Work Act 2005, or of any other current or future common law duty of care owed by the manufacturer or by the Certificate holder.

5.6 The NSAI is not responsible to any person or body for loss or damage including personal injury arising as a direct or indirect result of the use of this product or process.

5.7 Where reference is made in this Certificate to any Act of the Oireachtas, Regulation made thereunder, Statutory Instrument, Code of Practice, National Standards, manufacturer's instructions, or similar publication, it shall be construed as reference to such publication in the form in which it is in force at the date of this Certification.

The Irish Agrément Board

This Certificate No. **08/0310** is accordingly granted by the NSAI to **Thermohouse Ltd.** on behalf of The Irish Agrément Board.

Date of Issue: **April 2008**

Signed

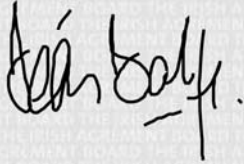

Seán Balfe
Director of the Irish Agrément Board

Readers may check that the status of this Certificate has not changed by contacting NSAI Agrément, NSAI, 1 Swift Square, Northwood, Santry, Dublin 9, Ireland.
Telephone: (01) 807 3800. Fax: (01) 807 3842. www.n sai.ie

Revisions: November 2010, June 2011, May 2013

- Cill details updated.
- Extension of certificate to 6 storeys in height, inclusion of graphite-enhanced EPS.
- General information and diagram updates.