



INSTYTUT TECHNIKI BUDOWLANEJ
PL 00-611 WARSZAWA
ul. Filtrowa 1
tel.: (+48 22) 825-04-71
(+48 22) 825-76-55
fax: (+48 22) 825-52-86
www.itb.pl



Member of



www.eota.eu

European Technical Assessment

**ETA-07/0018
of 13/06/2017**

General Part

Technical Assessment Body issuing the European Technical Assessment

Instytut Techniki Budowlanej

Trade name of the construction product

ICF SYSTEM

Product family to which the construction product belongs

Non load-bearing permanent shuttering kit based on elements of EPS

Manufacturer

Thermohouse Ltd
Coolcaslagh, Killarney
Co Kerry, Ireland

Manufacturing plant

Thermohouse Ltd
Coolcaslagh, Killarney
Co Kerry, Ireland

This European Technical Assessment contains

41 pages including 2 Annexes which form an integral part of this Assessment

This European Technical Assessment is issued in accordance with Regulation (EU) No 305/2011, on the basis of

Guideline for European Technical Approval ETAG 009, Edition June 2002 "Non load-bearing permanent shuttering kits/systems based on hollow blocks or panels of insulating materials and sometimes concrete", used as European Assessment Document (EAD)

This version replaces

ETA-07/0018 issued on 02/05/2012

This European Technical Assessment is issued by the Technical Assessment Body in its official language. Translations of this European Technical Assessment in other languages shall fully correspond to the original issued document and should be identified as such.

Communication of this European Technical Assessment, including transmission by electronic means, shall be in full. However, partial reproduction may be made, with the written consent of the issuing Technical Assessment Body. Any partial reproduction has to be identified as such.

Specific Part

1 Technical description of the product

The non load-bearing permanent shuttering kit ICF SYSTEM consists of the Thermohouse elements made of expanded polystyrene (EPS) applied as the formwork for plain or reinforced concrete walls cast in-situ. The Thermohouse elements comprise of two walls of expanded polystyrene separated by steel or expanded polystyrene spacers. The spacers incorporated during production, connect the shuttering leaves and resist the pressure of the concrete during filling.

The kit consists of four groups of standard shuttering elements: Thermohouse 250 of the overall thickness 250 mm, Thermohouse 300 of the overall thickness 300 mm, Thermohouse 400 of the overall thickness 400 mm and Thermohouse 450 of the overall thickness 450 mm. The thickness of the inner shuttering leaf in all these elements is 50 mm and the distance of two walls (the thickness of the concrete core) is 150 mm. The thickness of the outer shuttering leaf depends on the type of element (see Annexes A1 to A16). The height of the shuttering elements is 250 mm and the length of the standard elements is 750 mm or 1200 mm. The upper and the lower surfaces of the shuttering leaves are tongue and groove to lock elements together.

The kit consists of the following shuttering elements:

- a) standard elements (see Annexes A1 to A16):
 - Thermohouse 250 with polystyrene spacers: TH-1, TH-2, TH-2L, TH-2R,
 - Thermohouse 250 with steel spacers: TH-8, TH-9,
 - Thermohouse 300 with polystyrene spacers: TH-14, TH-15L, TH-15R, TH-18L, TH-18R,
 - Thermohouse 400 with polystyrene spacers: TH-20, TH-21L, TH-21R, TH-26L, TH-26R,
 - Thermohouse 400 with steel spacers: TH-20/B, TH-21L/B, TH-21R/B, TH-26L/B, TH-26R/B,
 - Thermohouse 450 with polystyrene spacers: TH-22, TH-23L, TH-23R, TH-25L, TH-25R,
 - Thermohouse 450 with steel spacers: TH-22/B, TH-23L/B, TH-23R/B, TH-25L/B, TH-25R/B,
- b) tie beam element TH-3 (see Annex A17),
- c) lintel element TH-4 (see Annex A17),
- d) hinge elements: TH-11/12, TH-13 (see Annex A18),
- e) additional elements: TH-16, TH-17, TH-19, TH-24, TH-27 (see Annexes A19, A20 and A21).

The views and vertical sections of standard shuttering elements are shown in Annexes A22 to A25. The dimensions and tolerances of the shuttering elements not indicated in Annexes A1 to A25 are given in the technical documentation of this ETA.

For the EPS shuttering elements and for the EPS leaves of the shuttering elements with steel spacers expanded polystyrene EPS-EN 13163-T1-L2-W2-S5-P5-BS200-CS(10)150-DS(N)2-DS(70,-)1-TR200-WL(T)3, density not less than 24 kg/m³, shall be used.

Special elements as lintel element, tie beam element, hinge elements (for curved walls) and additional elements are also part of the kit (see Annexes A17 to A21).

For the steel spacers the profiles made of galvanized steel sheet of the thickness not less than 0,5 mm, grade DX51D according to EN 10327, shall be used.

2 Specification of the intended use in accordance with the applicable European Assessment Document (EAD)

The non load-bearing permanent shuttering kit ICF SYSTEM is intended to be used for construction of load-bearing or non load-bearing internal or external walls, above or below ground, including those which are subjected to fire regulations.

When using this type of construction below ground a waterproofing as well as the layer protecting the waterproofing from mechanical damage shall be used according to the national provisions and to the ETA-holder's installation instruction.

The walls made of the shuttering kit ICF SYSTEM may be used in building works designed according to EN 1992-1-1 or to the applicable national rules. For the concrete walls of a grid type EN 1992 (parts 1-1 and 1-6) do not provide a design method for in plane shear forces. For this reason, Annex B of ETAG 009 gives a proposal that can be used in absence of applicable national or harmonised methods.

The walls made of the shuttering kit ICF SYSTEM influence the flanking transmission of sound in building. This shall be considered in calculations of the sound insulation, according to EN 12354-1.

The installation of shuttering elements, concreting and finishing are given in Annex B1.

The provisions made in this European Technical Assessment are based on an assumed working life of the shuttering kit of at least 50 years, provided that the shuttering kit in end use conditions is subjected to an appropriate use and maintenance. The indications given on the working life cannot be interpreted as a guarantee given by the manufacturer or the Assessment Body, but should only be regarded as means for choosing the right products in relation to the expected economically reasonable working life of the works.

3 Performance of the product and references to the methods used for its assessment

3.1 Performance of the product

3.1.1 Mechanical resistance and stability (BWR 1)

3.1.1.1 Resulting structural pattern

In end use conditions the walls made of ICF SYSTEM shuttering elements are walls of a grid type – in case of walls made of elements with expanded polystyrene spacers, and continuous type – in case of walls made of elements with steel spacers, according to ETAG 009, clause 2.2.

3.1.1.2 Efficiency of filling

Considering the instructions of Annexes A and B and the installation guide of the ETA-holder the efficient filling without bursting of the shuttering and without voids or any uncovered reinforcement in the concrete column is possible.

3.1.1.3 Possibility of steel reinforcement

The instructions in the installation guide of the ETA-holder enable installation of walls steel reinforcement according to EN 1992-1-1 or corresponding national rules.

3.1.2 Safety in case of fire (BWR 2)

3.1.2.1 Reaction to fire

Thermohouse shuttering elements are the products of the reaction to fire class E according to EN 13501-1+A1.

3.1.2.2 Resistance to fire

Fire resistance classification of the load-bearing walls made of Thermohouse 250, Thermohouse 300, Thermohouse 400 and Thermohouse 450 elements according to EN 13501-2+A1 is given in Table 1.

For the walls with other finishes: no performance assessed.

Table 1

Outer finish	Inner finish	Type of spacers	Maximum load, kN/m	Resistance to fire class
Rendering: mineral base coat + glass fibre mesh + mineral finishing coat	Gypsum plasterboards 2 x 12,5 mm	Expanded polystyrene or steel	105	REI 60(i→o), REI 60(o→i)-ef
	Gypsum plaster 25 mm thick			REI 30(i→o)
	Gypsum plasterboard 1 x 12,5 mm	Expanded polystyrene	67	REI 30(i→o), REI 60(o→i)-ef
		Steel		REI 60(i→o), REI 60(o→i)-ef
Note: The outer and inner finishes are not part of the kit covered by this ETA.				

3.1.3 Hygiene, health and the environment (BWR 3)

3.1.3.1 Content and/or release of dangerous substances

The manufacturer's declaration regarding to the chemical composition of the Thermohouse shuttering elements has been deposited in Instytut Techniki Budowlanej.

Regarding the dangerous substances, there may be requirements applicable to the products falling within its scope (e.g. transposed European legislation and national laws, regulations and administrative provisions). In order to meet the provisions of the Construction Products Regulation, these requirements need also to be complied with, when and where they apply.

3.1.3.2 Water vapour permeability

Results of the tests according to EN 12086 (test conditions A) indicate the water vapour diffusion resistance factor of expanded polystyrene $\mu = 51,4$.

The value of water vapour diffusion equivalent air layer thickness $s_d = 2$ m is assumed for the outer finish according to ETAG 004. The values for the water vapour diffusion resistance factor of concrete and other materials are tabulated in EN ISO 10456.

According to the calculations in accordance with EN ISO 13788, the annual moisture balance and the maximum amount of interstitial condensation will be on the safe side taking into account the inner and outer finishes given in Table 1.

3.1.4 Safety and accessibility in use (BWR 4)

3.1.4.1 Bond strength between the shuttering elements and the concrete column

The bond strength is at least equal to the resisting concrete pressure of the shuttering elements according to clause 3.1.4.2.

3.1.4.2 Resistance to concrete pressure

To resist the concrete pressure the bending tensile strength of the shuttering leaves shall be more than 200 kPa (see designation code of EPS given in clause 1), the tensile strength of the polystyrene spacers shall be more than 200 kPa (see also designation code of EPS given in clause 1) and the strength to pull out of the steel spacers more than 1000 N.

Additionally the fitness for the intended use in relation to resistance to concrete pressure has been determined by testing of the complete shuttering made of Thermohouse 250 elements with EPS spacers.

The requirements according to ETAG 009, chapter 6.4.2 are met.

3.1.4.3 Safety against personal injury by contact

Delivered on site the shuttering elements do not have sharp or cutting edges. The surface of the shuttering leaves is soft. There is no risk of abrasion or of cutting injuries.

3.1.5 Protection against noise (BWR 5)

3.1.5.1 Airborne sound insulation

Sound reduction indexes of external and internal walls made of Thermohouse shuttering elements, determined according to EN-ISO 717-1:1996, are given in Table 2.

For the walls with other finishes: no performance assessed.

Table 2

Type of the wall	Symbol of the element	Type of spacers	$R_w (C, C_{tr}), \text{dB}$
External walls			
<ul style="list-style-type: none"> - outer finish – rendering of the thickness 6 mm (mineral base coat + glass fibre mesh + mineral finishing coat) - inner finish – gypsum plasterboard of the thickness 12,5 mm bonded to the substrate using “dabs” of gypsum mortar 			
Thermohouse 250	TH-1	Expanded polystyrene	42 (-2, -4)
Thermohouse 300	TH-14		
Thermohouse 400	TH-20		
Thermohouse 450	TH-22		
Thermohouse 250	TH-8	Steel	44 (-4, -6)
Thermohouse 400	TH-20/B		
Thermohouse 450	TH-22/B		
Internal walls			
<ul style="list-style-type: none"> - outer and inner finishes made of gypsum plasterboard of the thickness 12,5 mm bonded to the substrate using “dabs” of gypsum mortar 			
Thermohouse 250	TH-8	Steel	45 (-1, -5)
Note: The outer and inner finishes are not part of the kit covered by this ETA.			

3.1.5.2 Sound absorption

No performance assessed.

3.1.6. Energy economy and heat retention (BWR 6)

3.1.6.1 Thermal resistance

The values of thermal resistance R of the shuttering elements in end use conditions (with concrete filling but without inner and outer finishes) are given in Table 3.

Table 3

Type of shuttering element	$R, \text{m}^2\text{K/W}$
Thermohouse 250 with expanded polystyrene spacers	3,1
Thermohouse 250 with steel spacers	1,9
Thermohouse 300 with expanded polystyrene spacers	4,5
Thermohouse 400 with expanded polystyrene spacers	7,5
Thermohouse 400 with steel spacers	7,1
Thermohouse 450 with expanded polystyrene spacers	8,9
Thermohouse 450 with steel spacers	8,5

3.1.6.2 Thermal inertia

The values of the heat capacity of concrete and expanded polystyrene are tabulated in EN ISO 10456.

3.1.6. Sustainable use of natural resources (BWR 7)

No performance assessed.

3.1.7. General aspects

3.1.7.1 Resistance to deterioration

Physical agents

As given in the designation code of the EPS material used (clause 1) the dimensions of the shuttering elements and the leaves in case of elements with steel spacers do not differ more than 1% after exposing them for 48 h at 70°C (DS(70,-)1).

Chemical agents

The steel spacers, necessary only for the resistance to concrete pressure, are made of galvanized steel sheet.

Biological agents

The application of EPS as thermal insulating material for decades has shown that it sufficiently protects against fungi, bacteria, algae and insects.

EPS does not provide a food value and in general it does not contain voids suitable for habitation by vermin.

3.1.7.2 Resistance to normal use damage

Incorporation of ducts

The instructions in the installations guide of the ETA-holder enable installation of horizontally passing ducts on site.

Fixing of objects

Fixing of objects in the shuttering elements is not possible, the part of fixings which is significant for the mechanical resistance shall be in the concrete core.

3.1.8. Methods used for the assessment

The assessment of fitness of the shuttering kit ICF SYSTEM for declared intended use has been made in accordance with the ETAG 009 *“Non-loadbearing permanent shuttering kits/systems based on hollow blocks or panels of insulating materials and sometimes concrete”*.

4 Assessment and verification of constancy of performance (AVCP) system applied, with reference to its legal base

According to Decision 98/279/EC of the European Commission the system 2+ of assessment and verification of constancy of performance (see Annex V to Regulation (EU) No 305/2011) applies.

5 Technical details necessary for the implementation of the AVCP system, as provided for in the applicable European Assessment Document (EAD)

Technical details necessary for the implementation of the AVCP system are laid down in the control plan which is deposited at Instytut Techniki Budowlanej.

For type testing the results of the tests performed as part of the assessment for the European Technical Assessment shall be used unless there are changes in the production line or plant. In such cases the necessary type testing has to be agreed between Instytut Techniki Budowlanej and the notified body.

Issued in Warsaw on 13/06/2017 by Instytut Techniki Budowlanej



Anna Panek, MSc
Deputy Director of ITB

TH-1

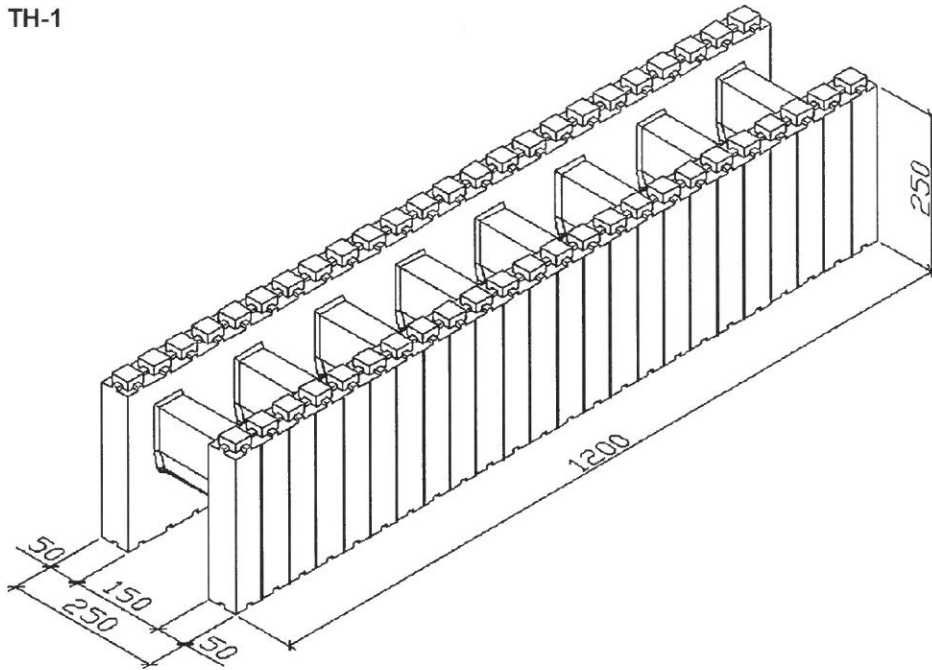

TH-2

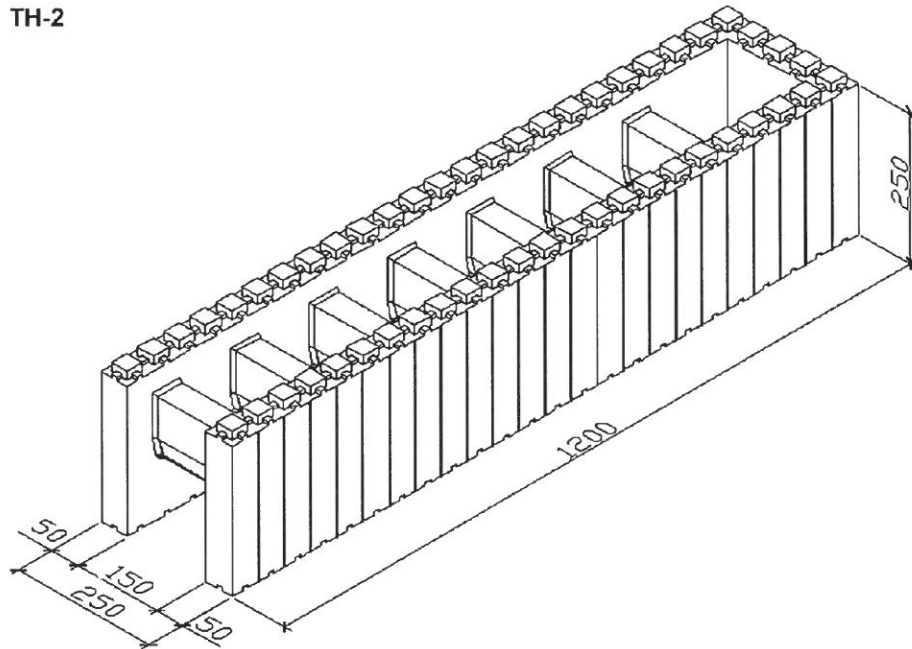

ICF SYSTEM

Thermohouse 250 standard elements

Annex A1
of European
Technical Assessment
ETA-07/0018

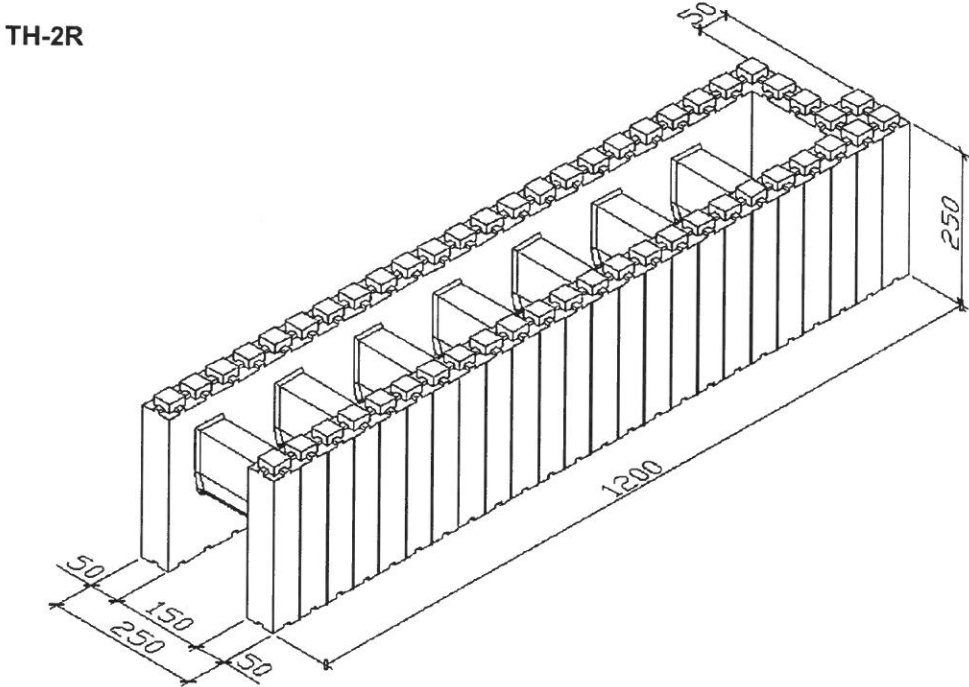
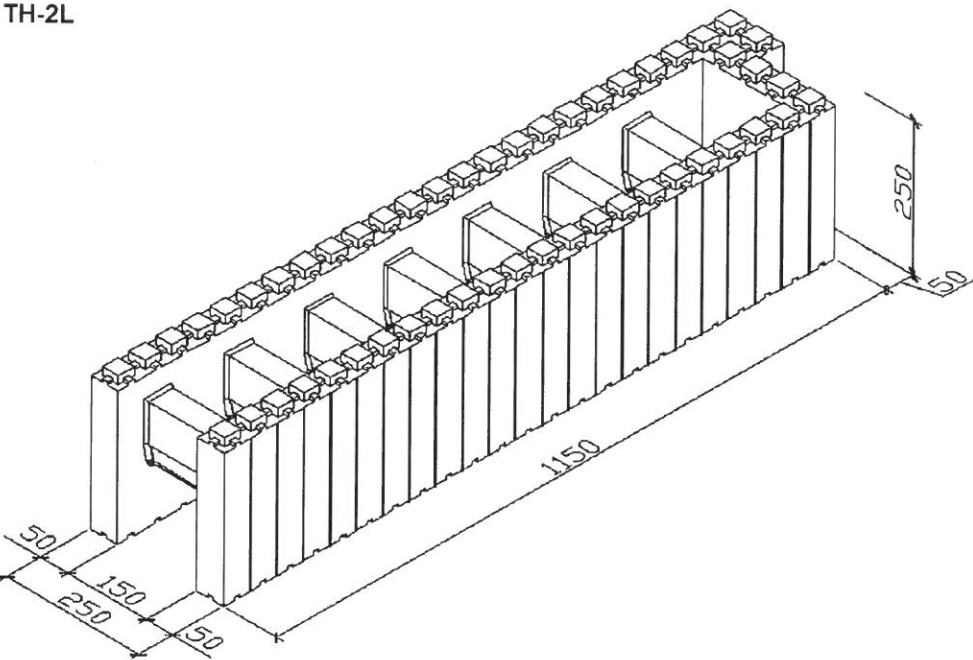

<p>ICF SYSTEM</p>	<p>Annex A2 of European Technical Assessment ETA-07/0018</p>
<p>Thermohouse 250 standard elements</p>	

TH-8

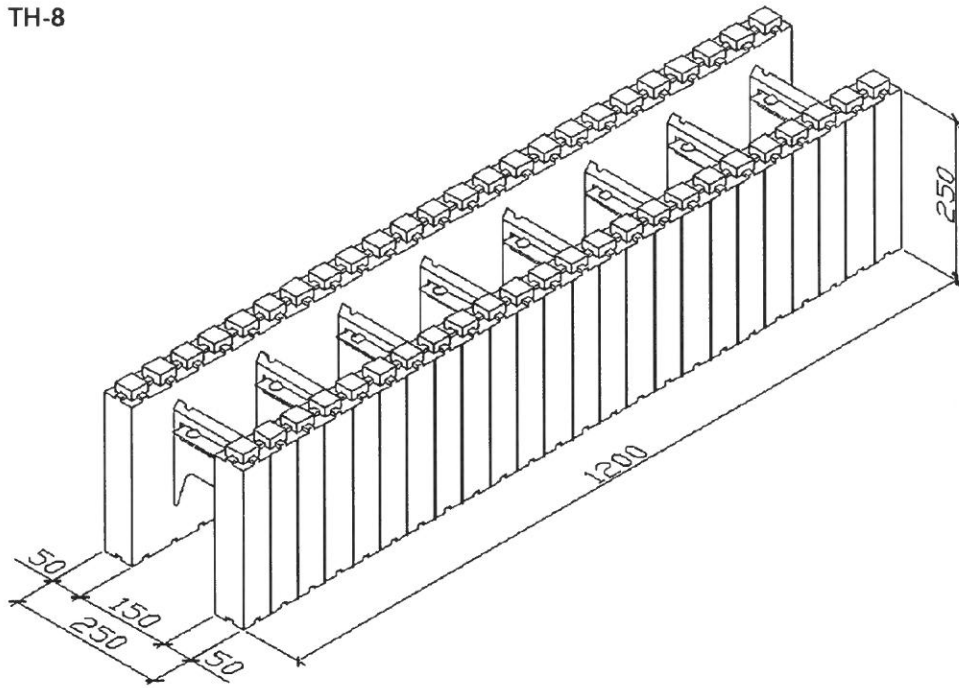

TH-9

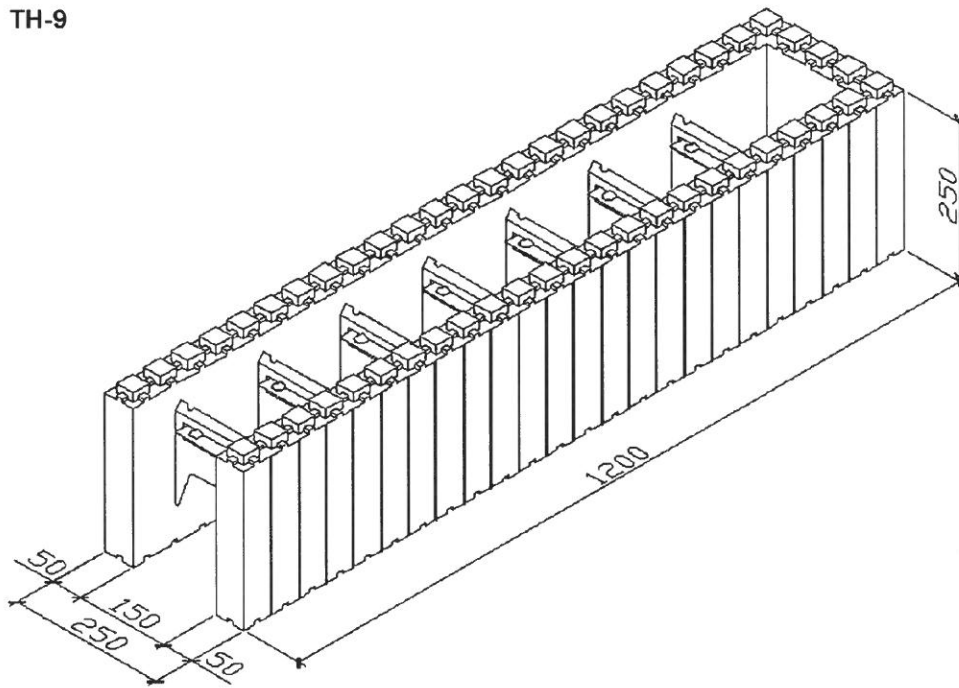

ICF SYSTEM

Thermohouse 250 standard elements

Annex A3
of European
Technical Assessment
ETA-07/0018

TH-14

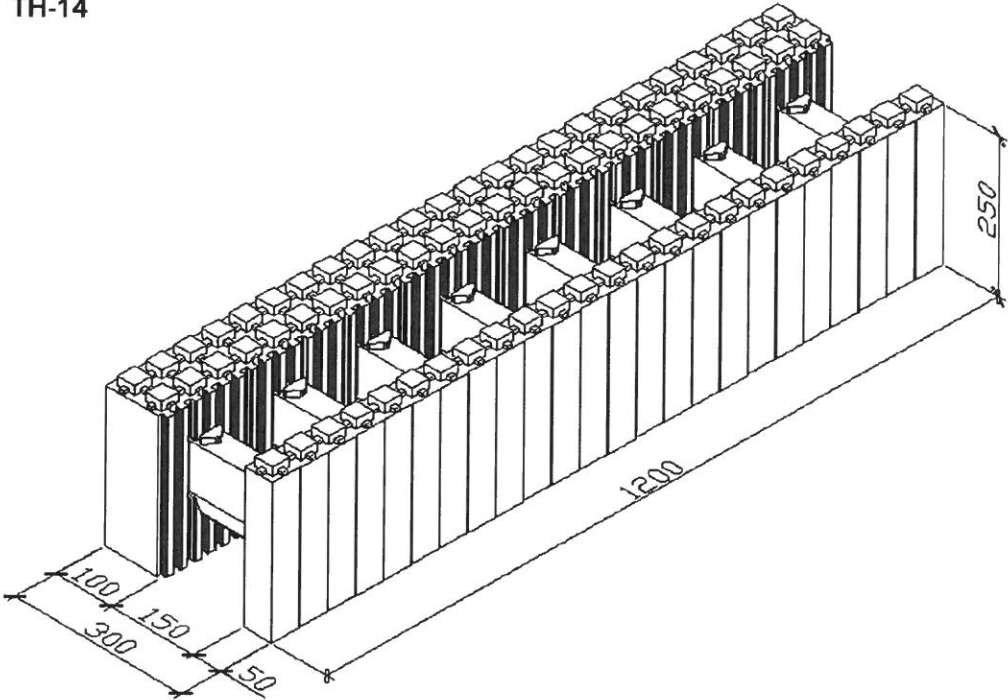

ICF SYSTEM

Thermohouse 300 standard elements

Annex A4
of European
Technical Assessment
ETA-07/0018

TH-15L

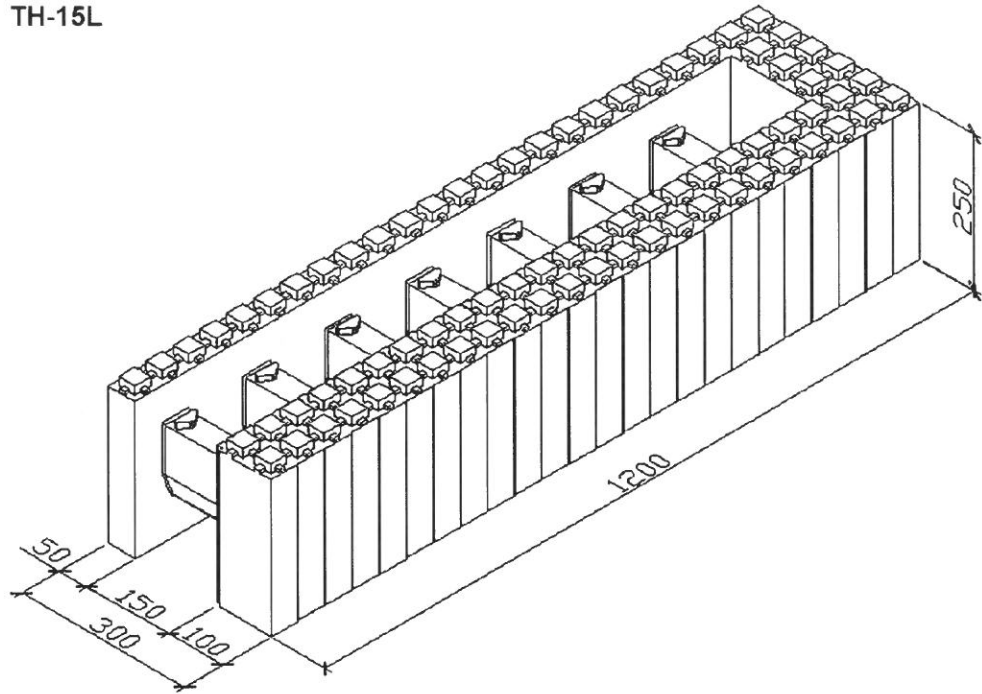

TH-15R

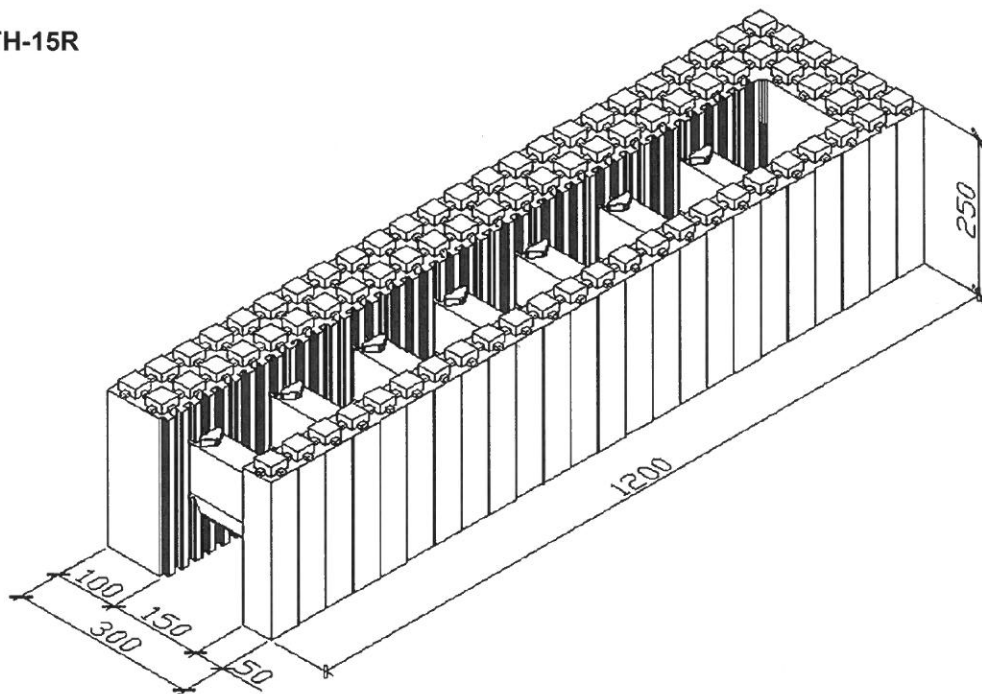

ICF SYSTEM

Thermohouse 300 standard elements

Annex A5
of European
Technical Assessment
ETA-07/0018

TH-18L

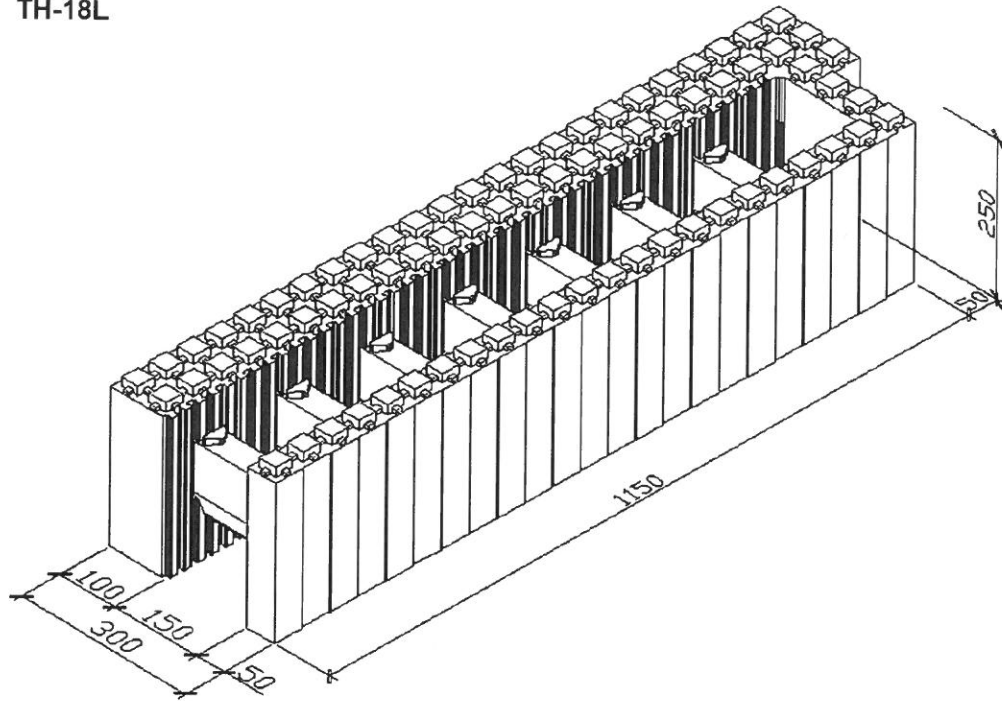

TH-18R

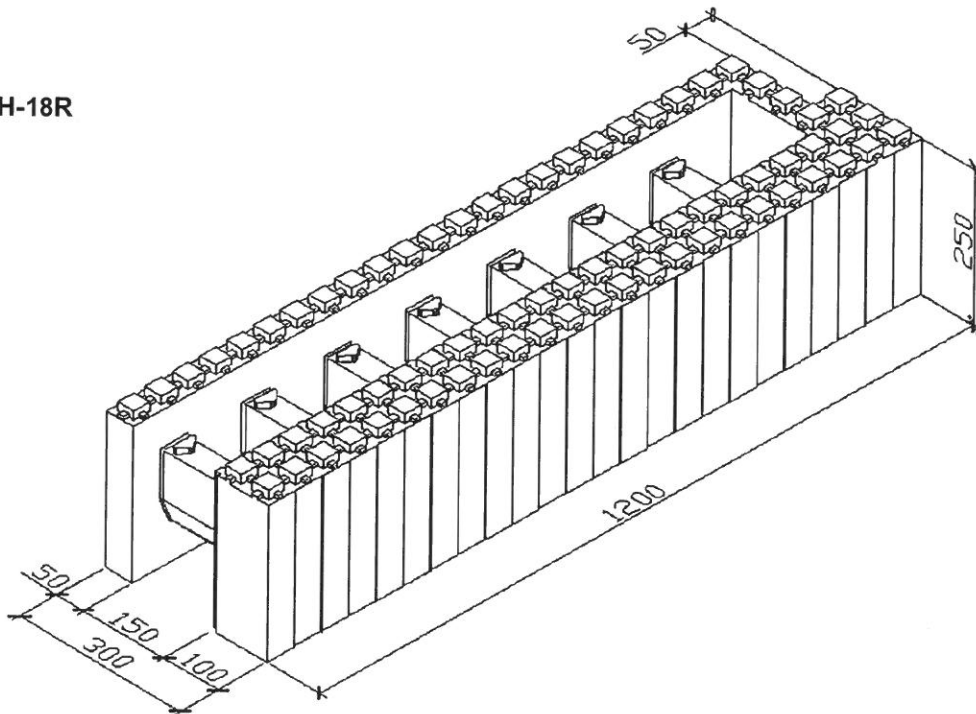

ICF SYSTEM

Thermohouse 300 standard elements

Annex A6
of European
Technical Assessment
ETA-07/0018

TH-20

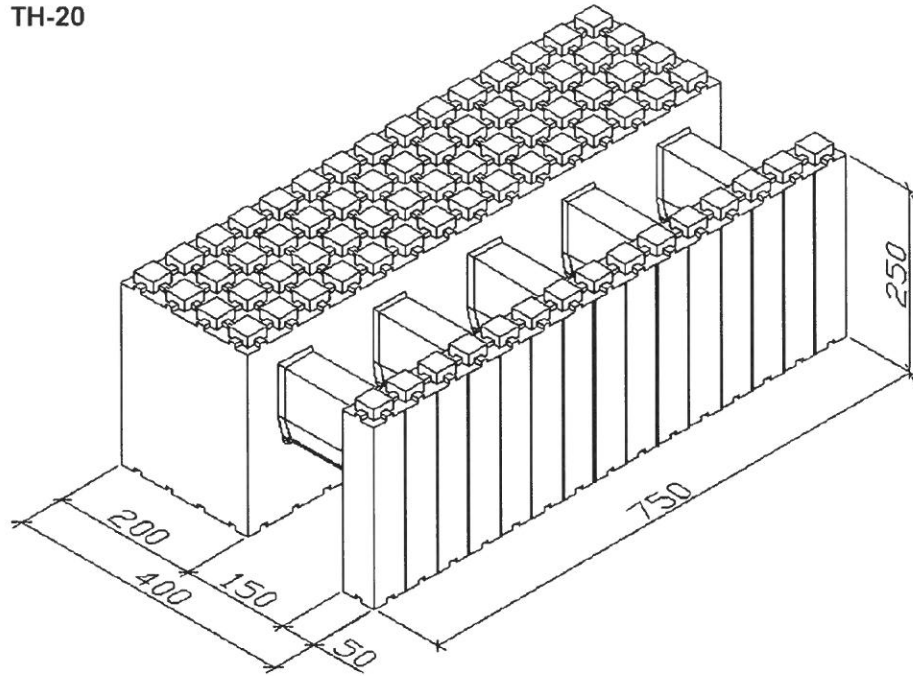

TH-20/B

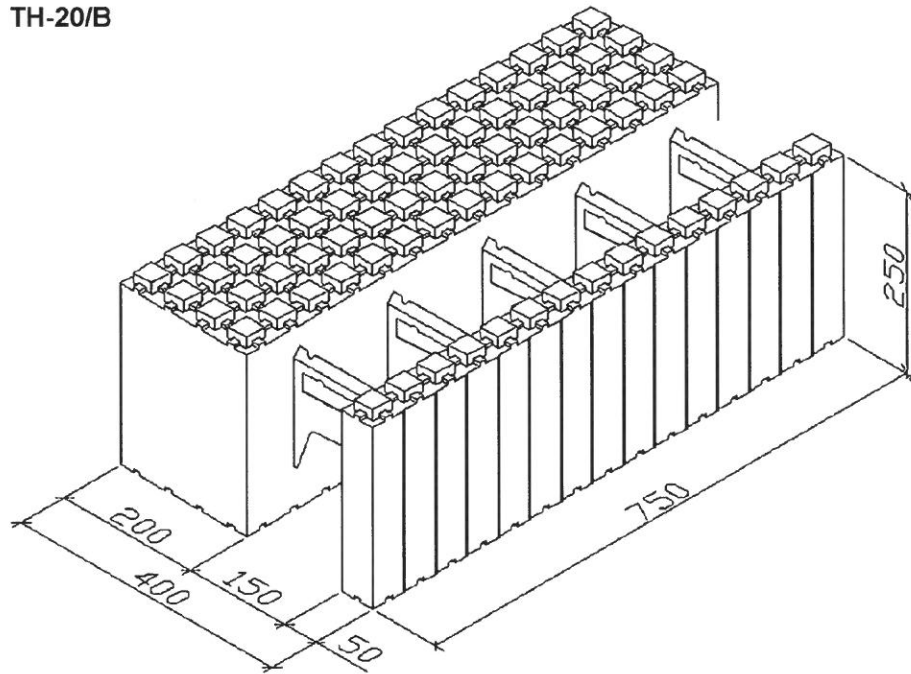

ICF SYSTEM

Thermohouse 400 standard elements

Annex A7
of European
Technical Assessment
ETA-07/0018

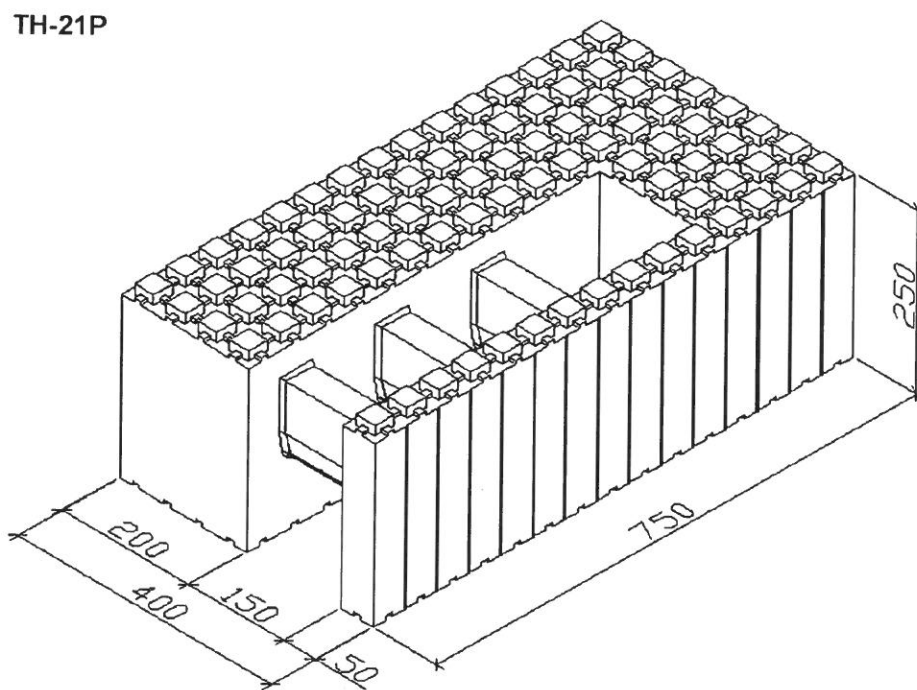
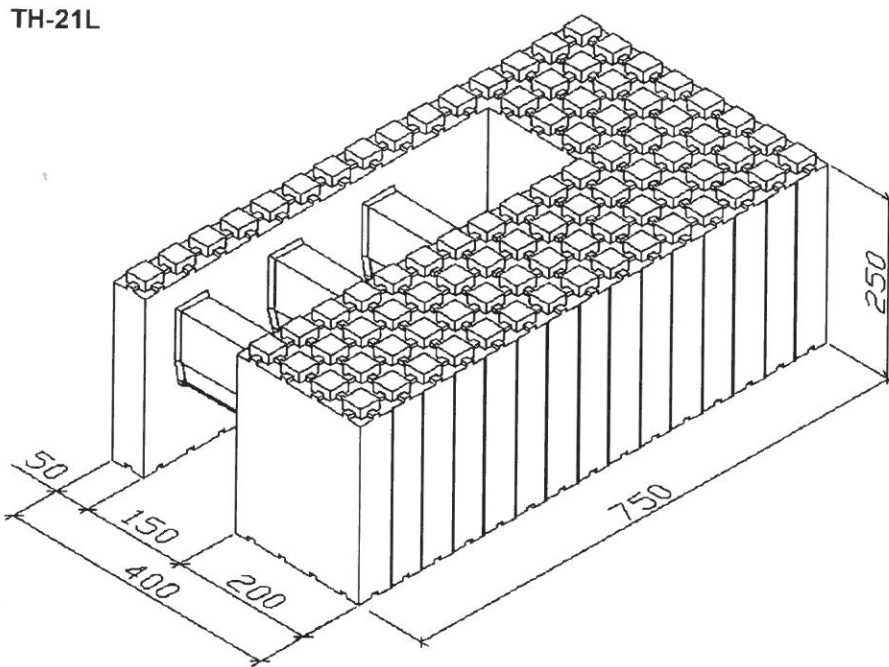

ICF SYSTEM

Thermohouse 400 standard elements

Annex A8
of European
Technical Assessment
ETA-07/0018

TH-21L/B

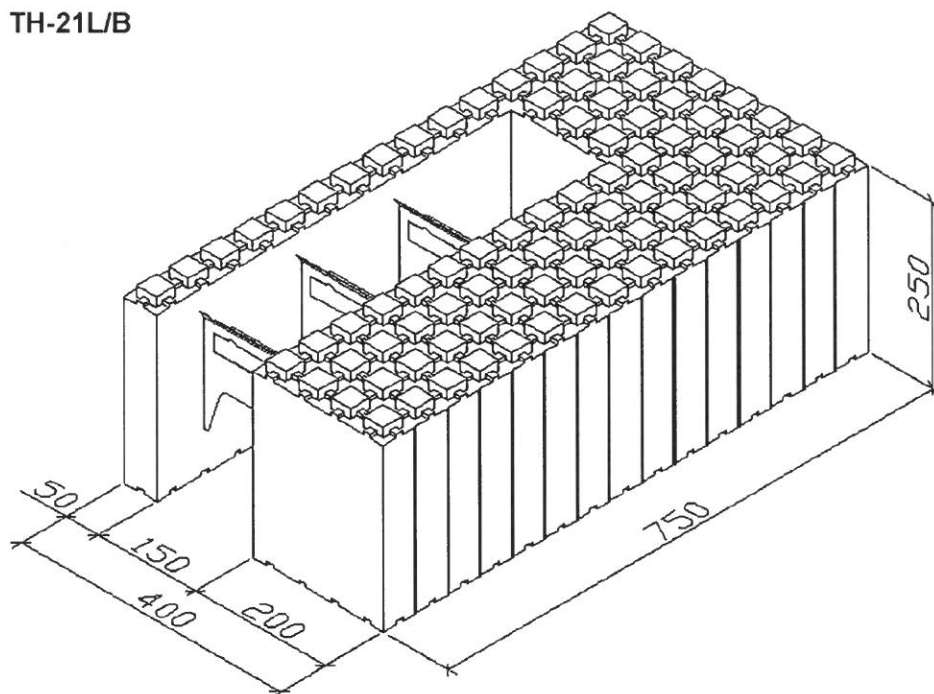

TH-21R/B

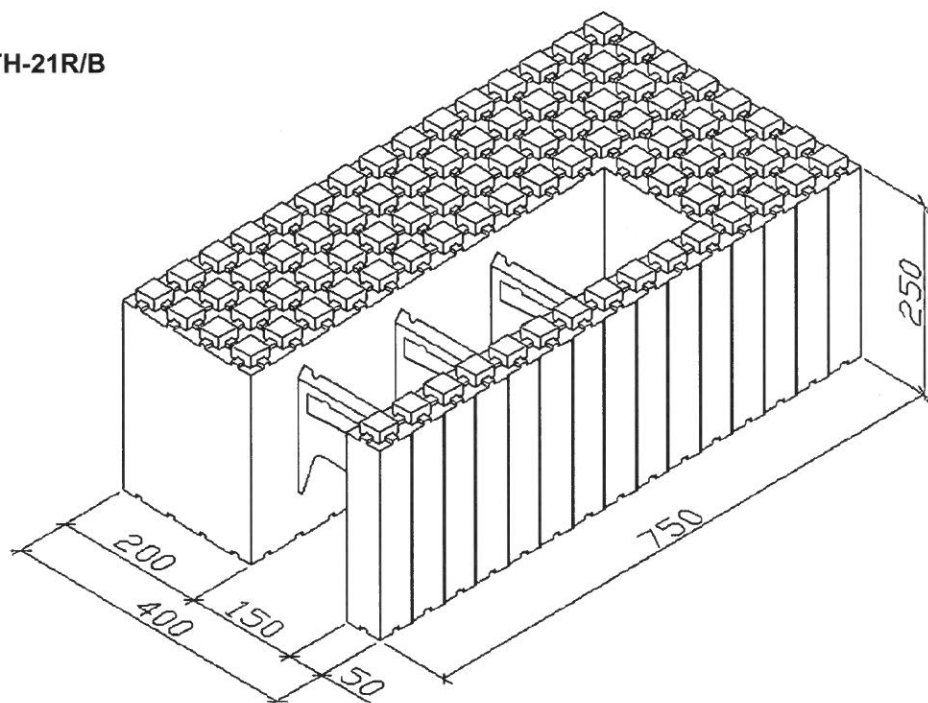

ICF SYSTEM

Thermohouse 400 standard elements

Annex A9
of European
Technical Assessment
ETA-07/0018

TH-26L

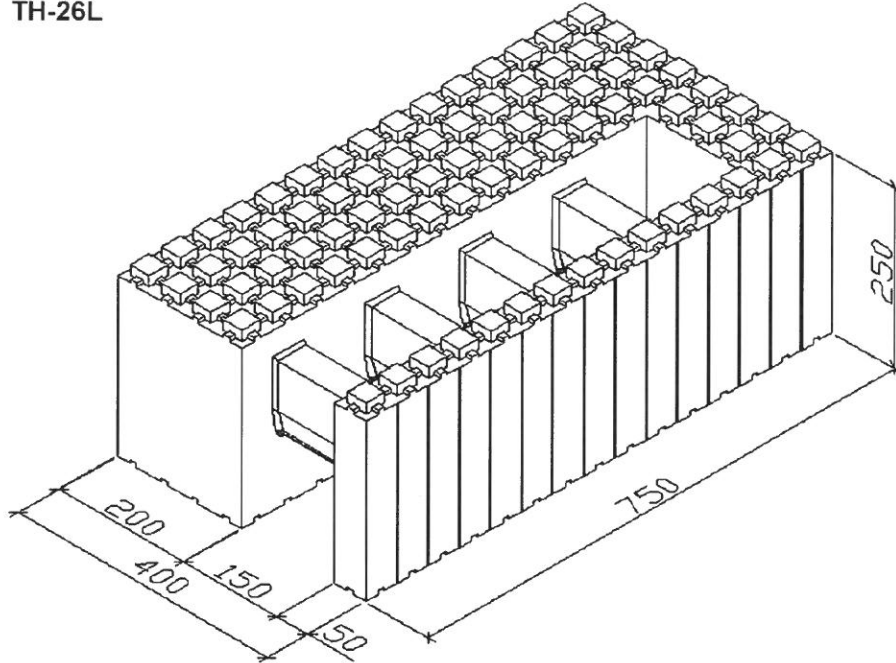

TH-26P

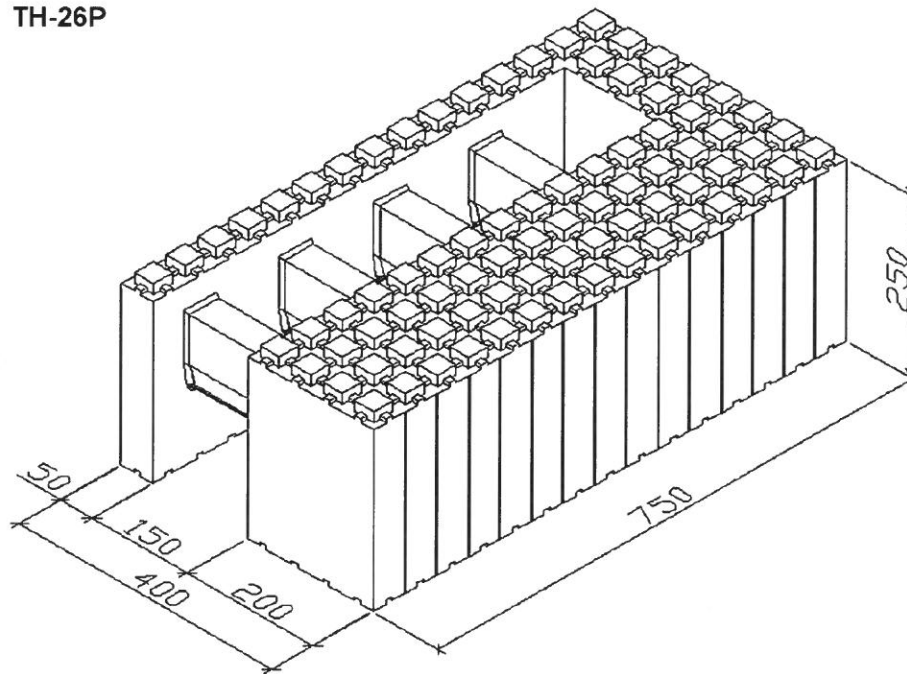

ICF SYSTEM

Thermohouse 400 standard elements

Annex A10
of European
Technical Assessment
ETA-07/0018

TH-26L/B

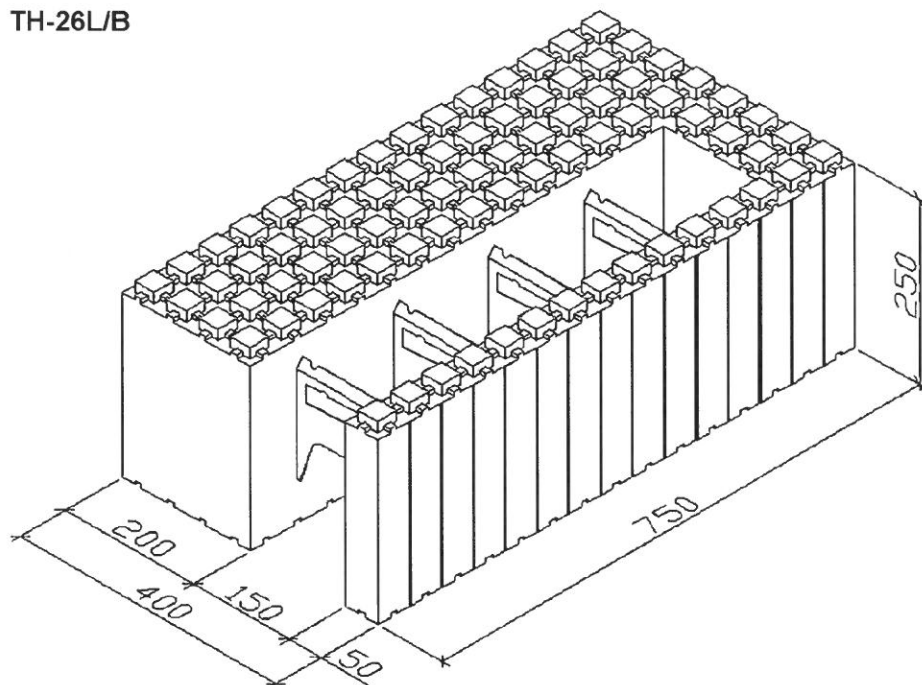

TH-26R/B

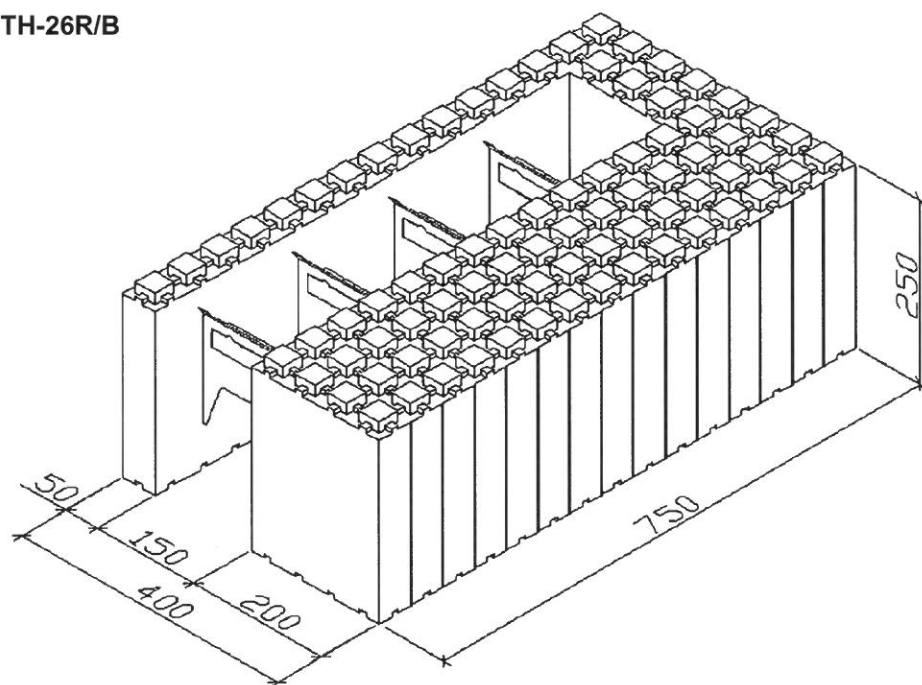

ICF SYSTEM

Thermohouse 400 standard elements

Annex A11
of European
Technical Assessment
ETA-07/0018

TH-22

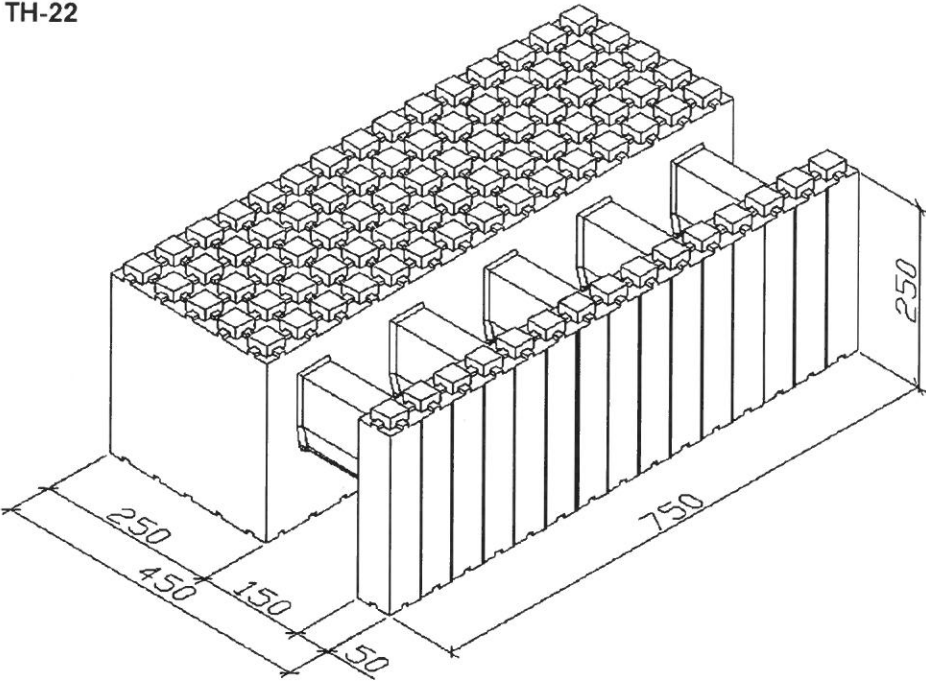

TH-22B

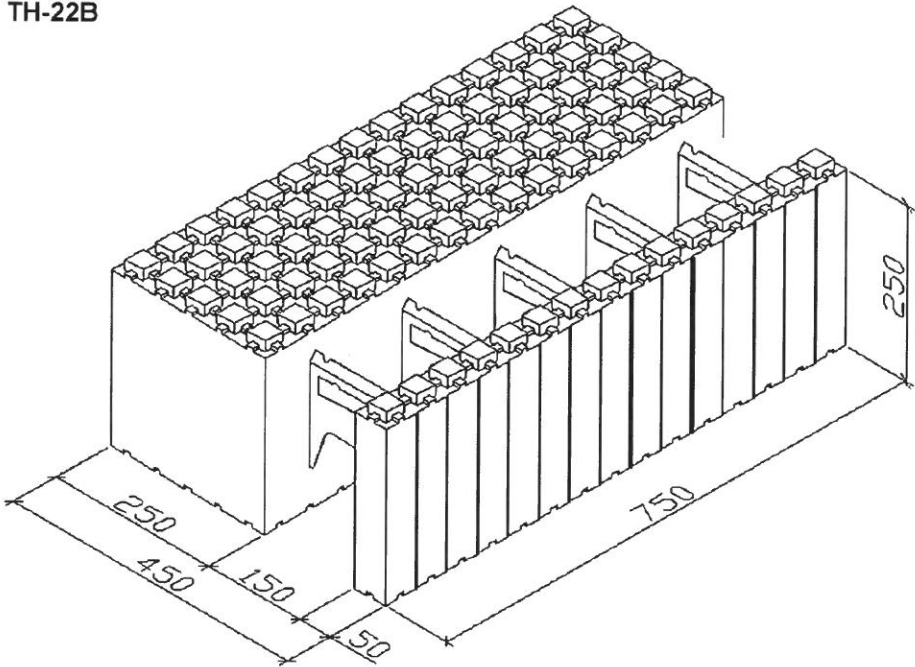

ICF SYSTEM

Thermohouse 450 standard elements

Annex A12
of European
Technical Assessment
ETA-07/0018

TH-23L

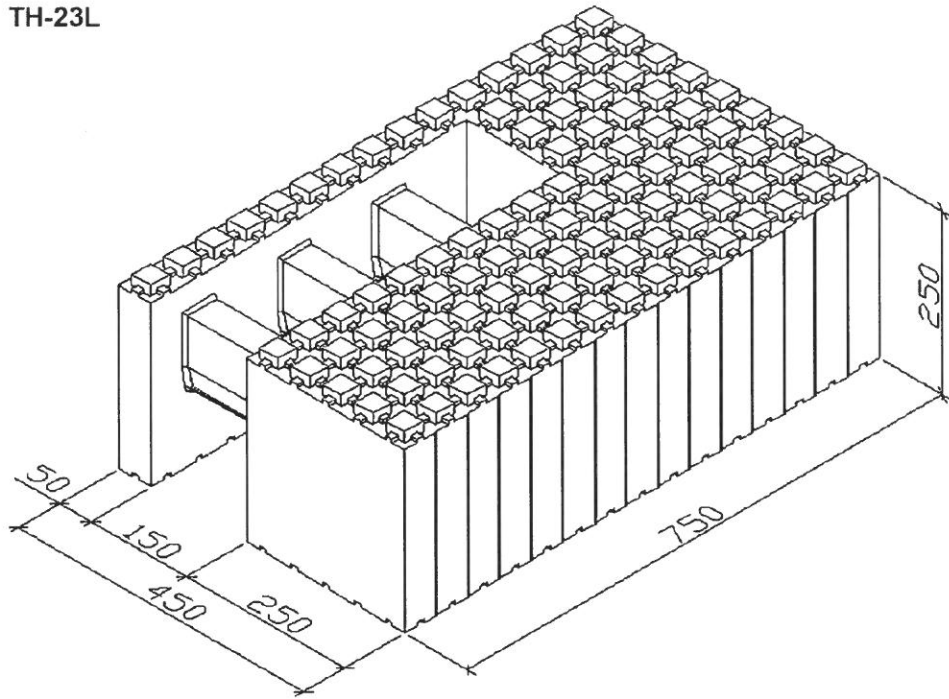

TH-23R

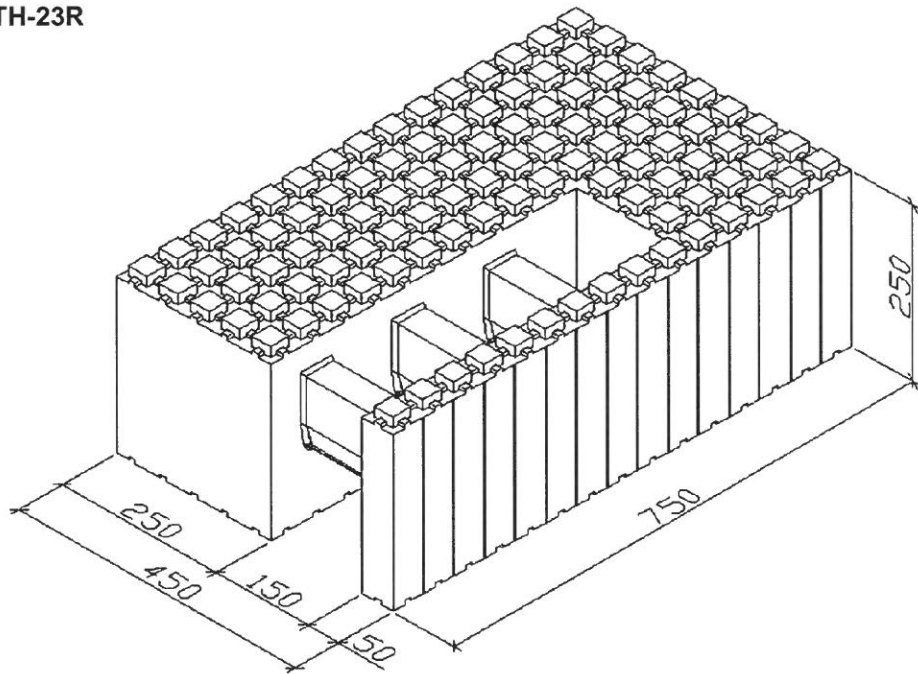

ICF SYSTEM

Thermohouse 450 standard elements

Annex A13
of European
Technical Assessment
ETA-07/0018

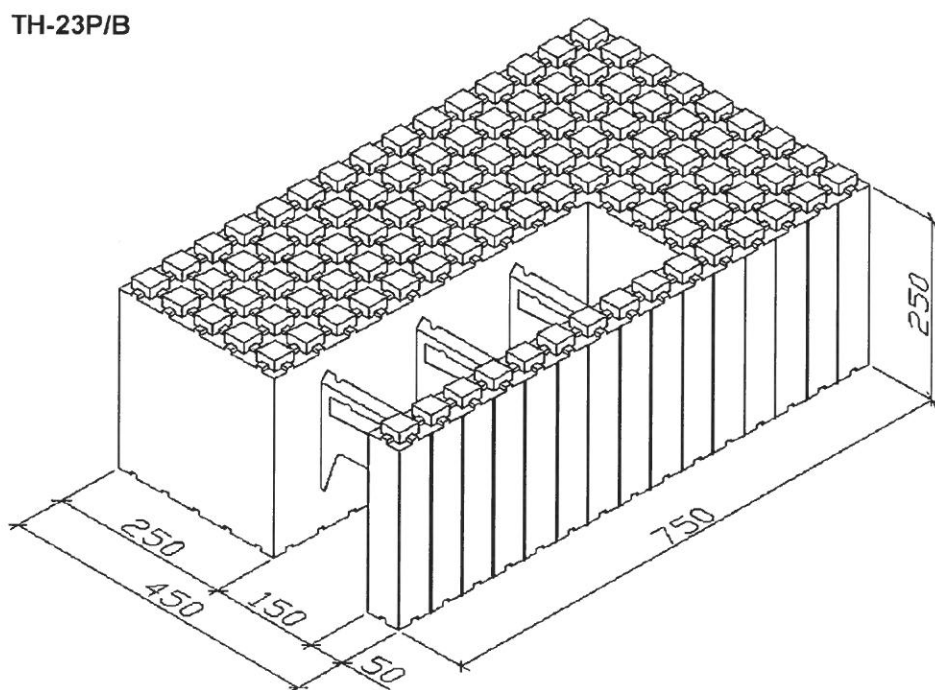
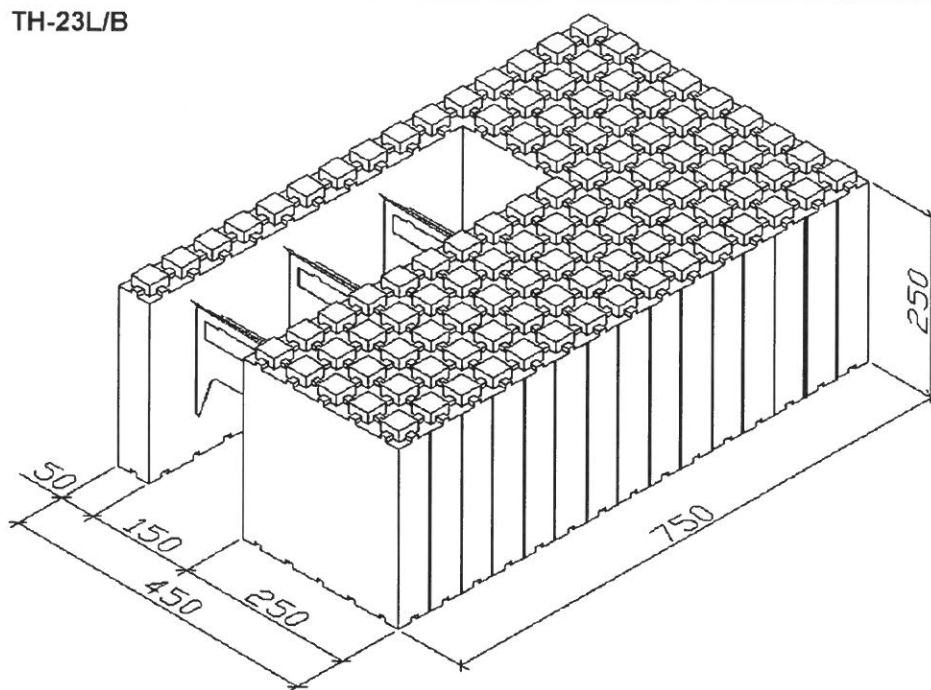

ICF SYSTEM

Thermohouse 450 standard elements

Annex A14
of European
Technical Assessment
ETA-07/0018

TH-25L

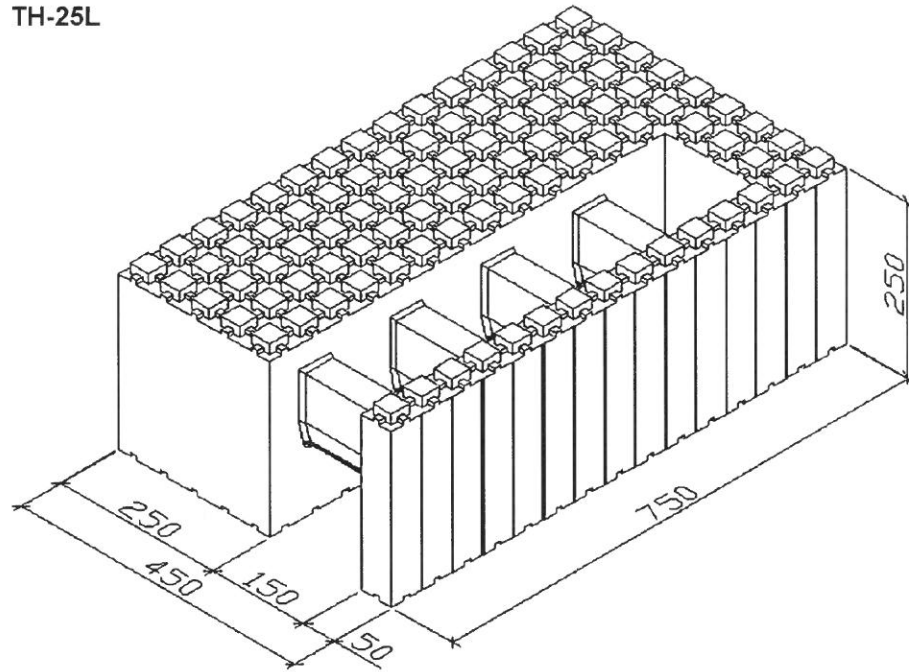

TH-25P

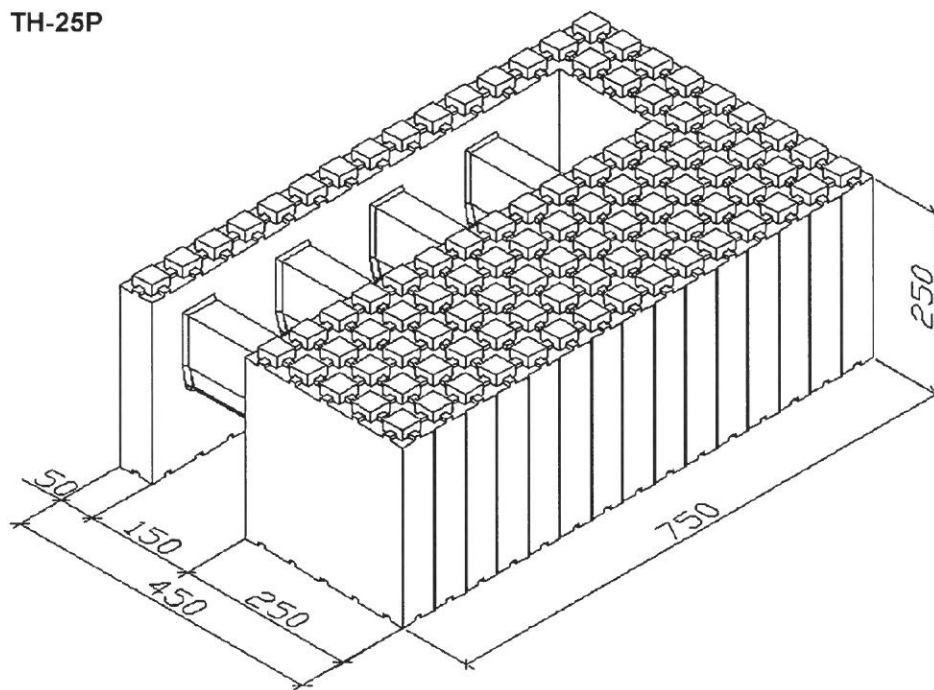

ICF SYSTEM

Thermohouse 450 standard elements

Annex A15
of European
Technical Assessment
ETA-07/0018

TH-25L/B

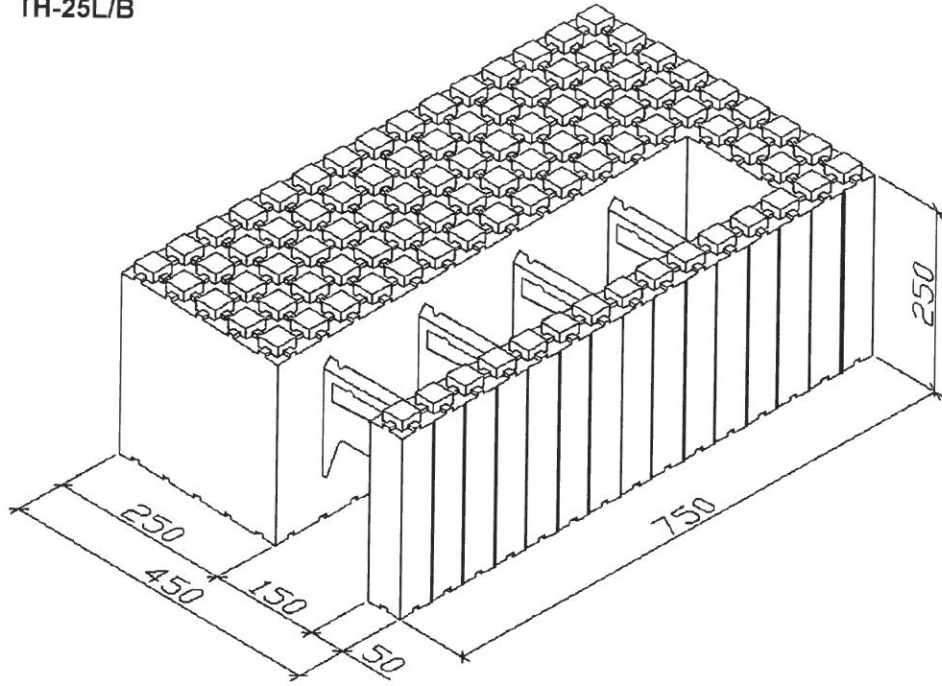

TH-25R/B

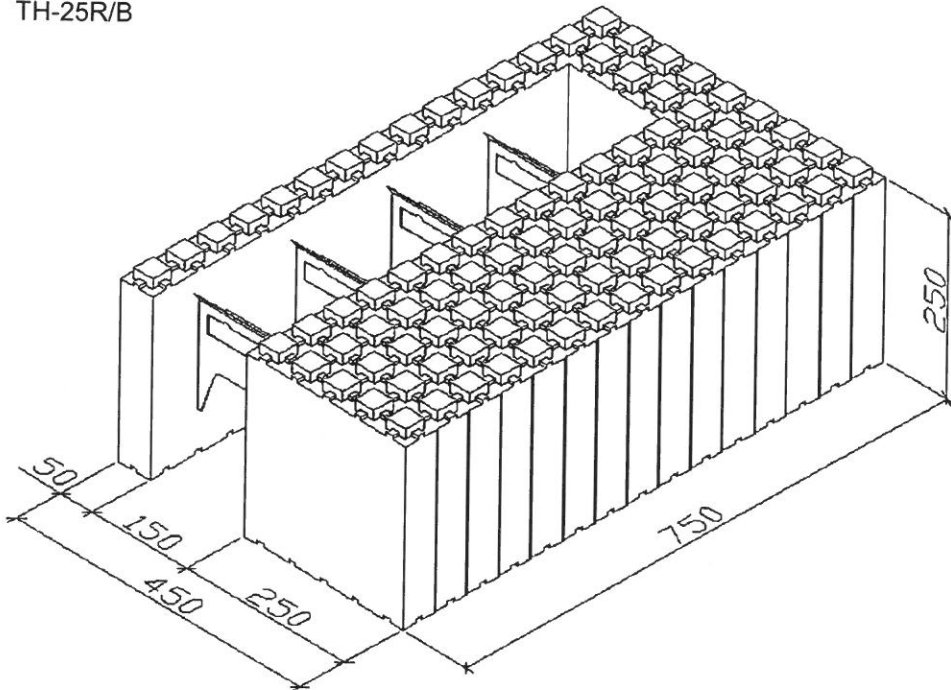

ICF SYSTEM

Thermohouse 450 standard elements

Annex A16
of European
Technical Assessment
ETA-07/0018

TH-3

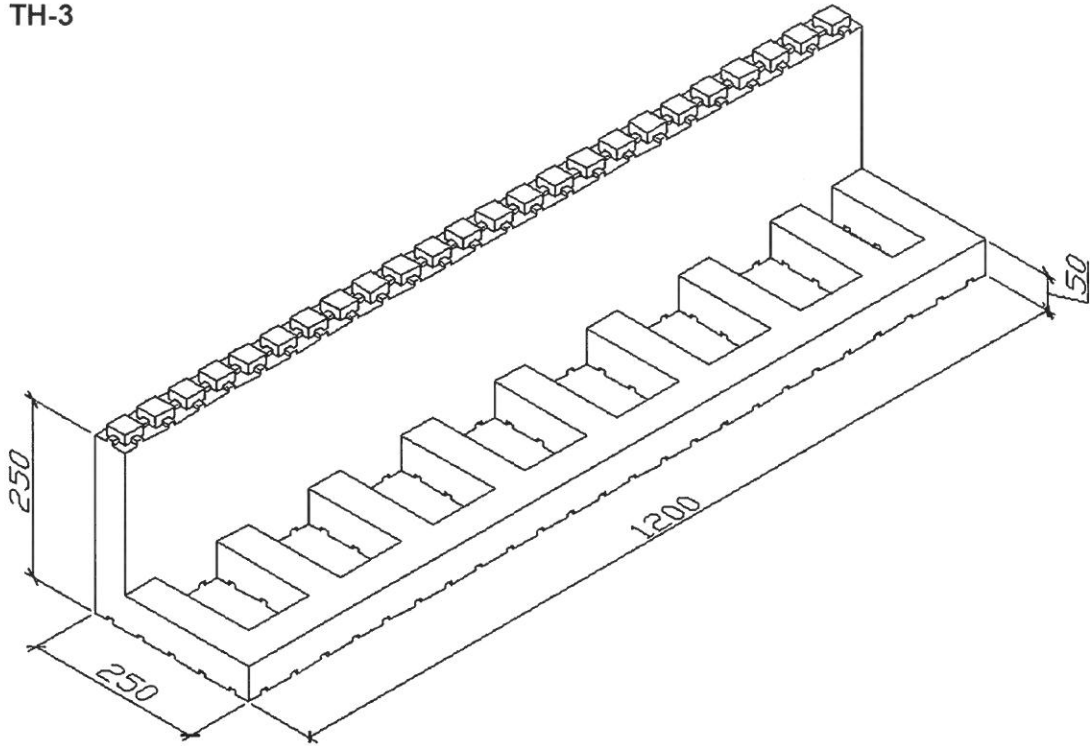

TH-4

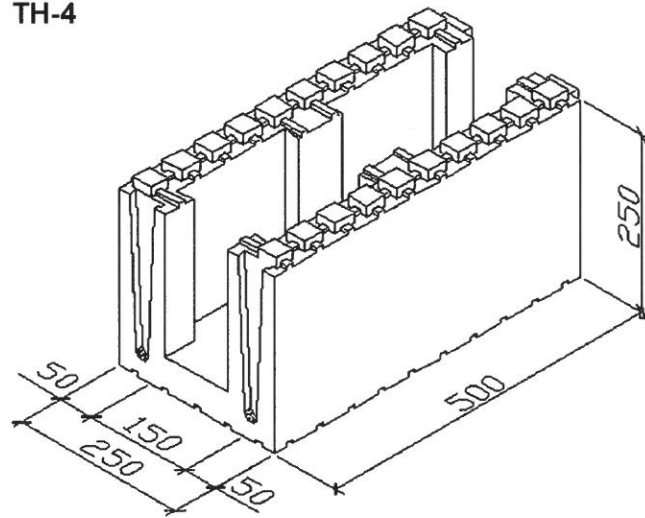

ICF SYSTEM

The beam TH-3 and lintel TH-4 elements

Annex A17
of European
Technical Assessment
ETA-07/0018

TH-11/12

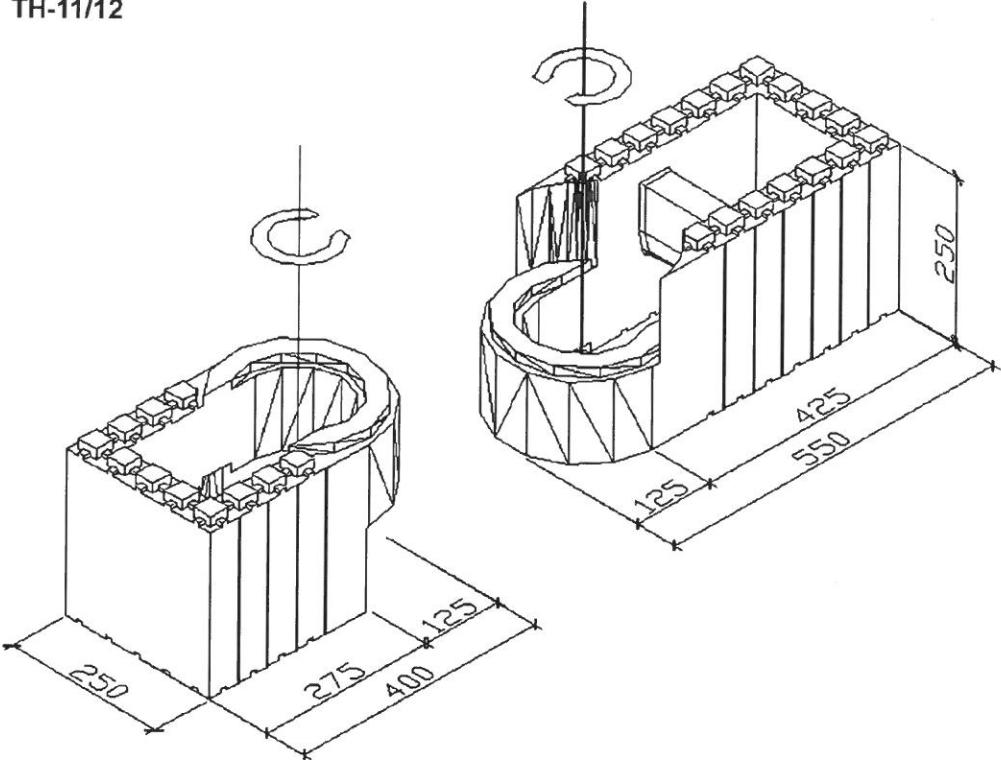

TH-13

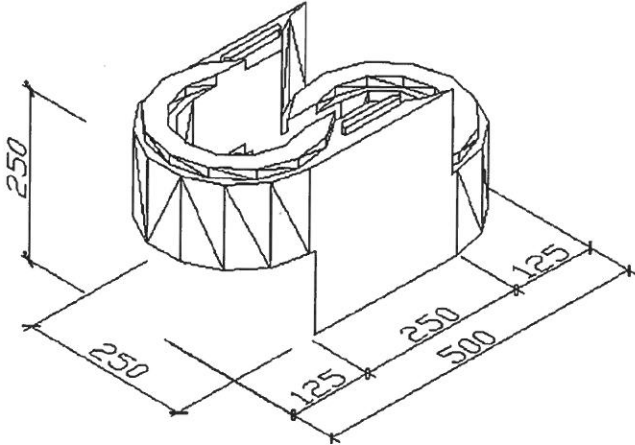

<p>ICF SYSTEM</p>	<p>Annex A18 of European Technical Assessment ETA-07/0018</p>
<p>Hinge elements</p>	

TH-16

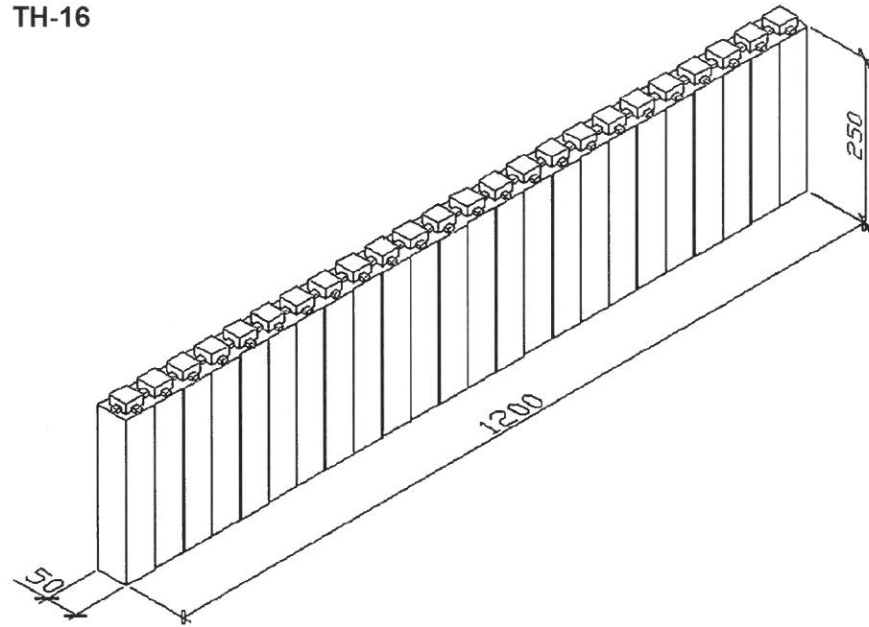

TH-17

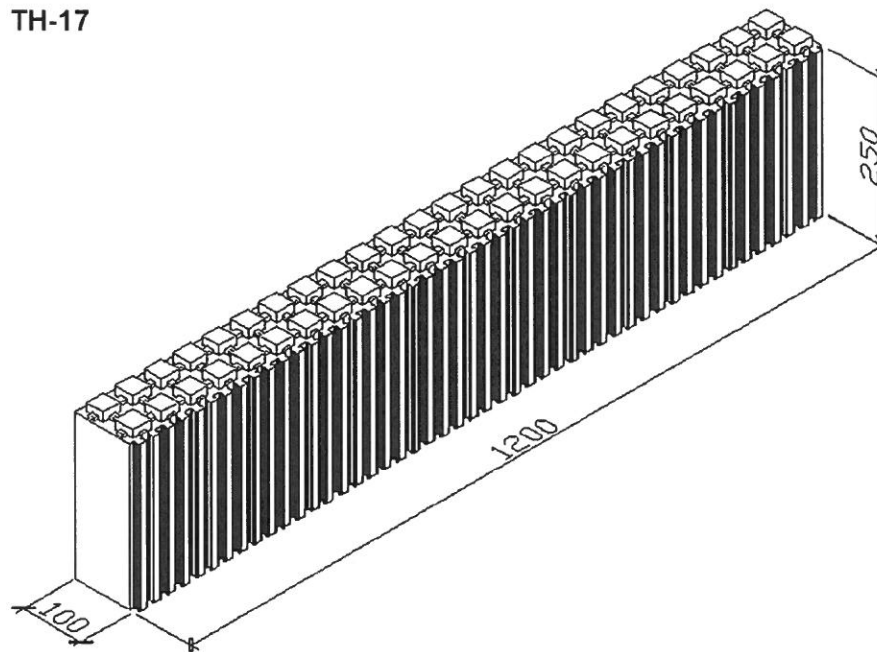

ICF SYSTEM

Additional elements

Annex A19
of European
Technical Assessment
ETA-07/0018

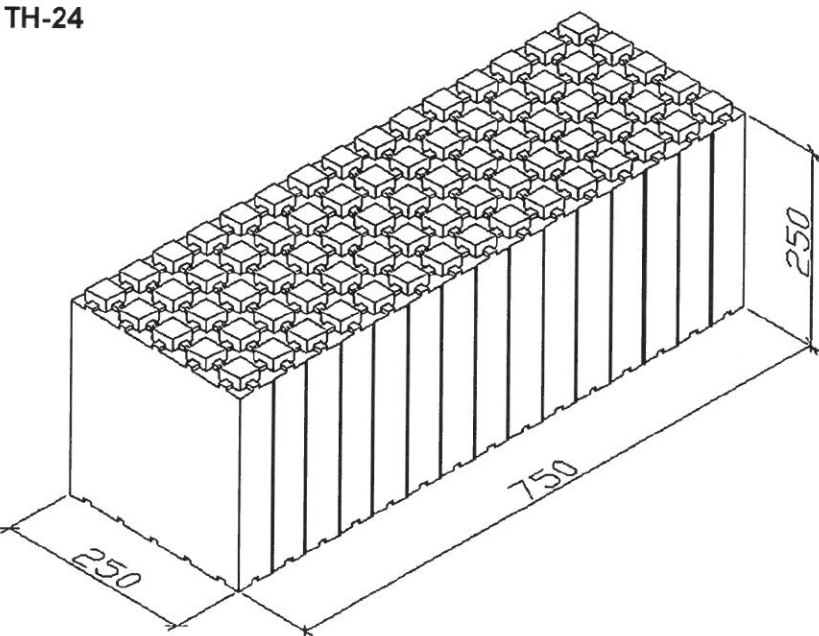
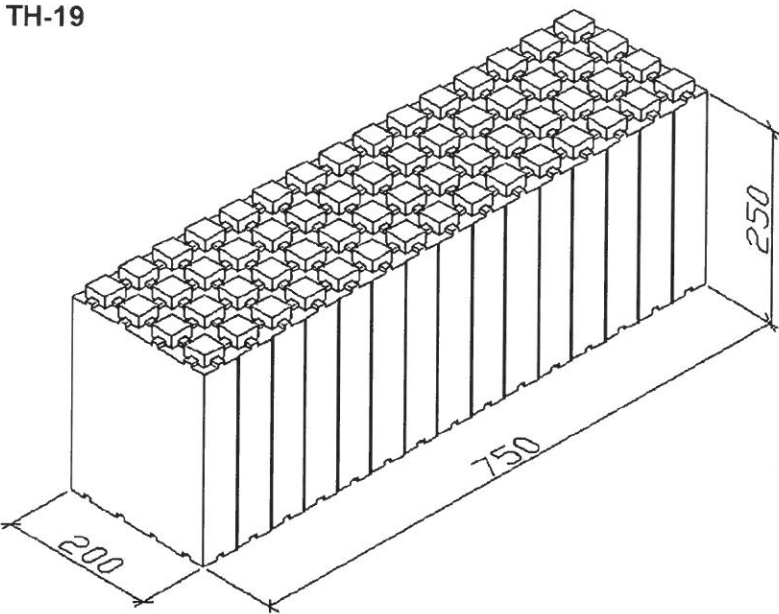

<p>ICF SYSTEM</p>	<p>Annex A20 of European Technical Assessment ETA-07/0018</p>
<p>Additional elements</p>	

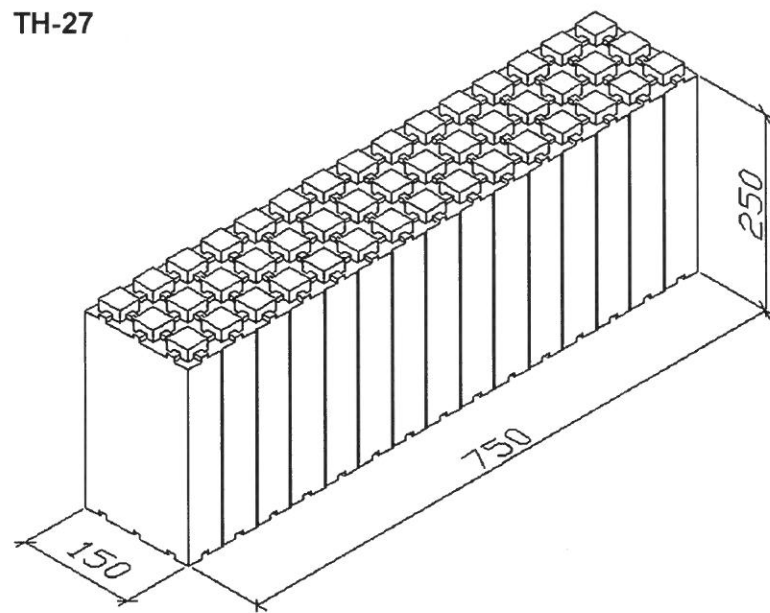

ICF SYSTEM

Additional elements

Annex A21
of European
Technical Assessment
ETA-07/0018

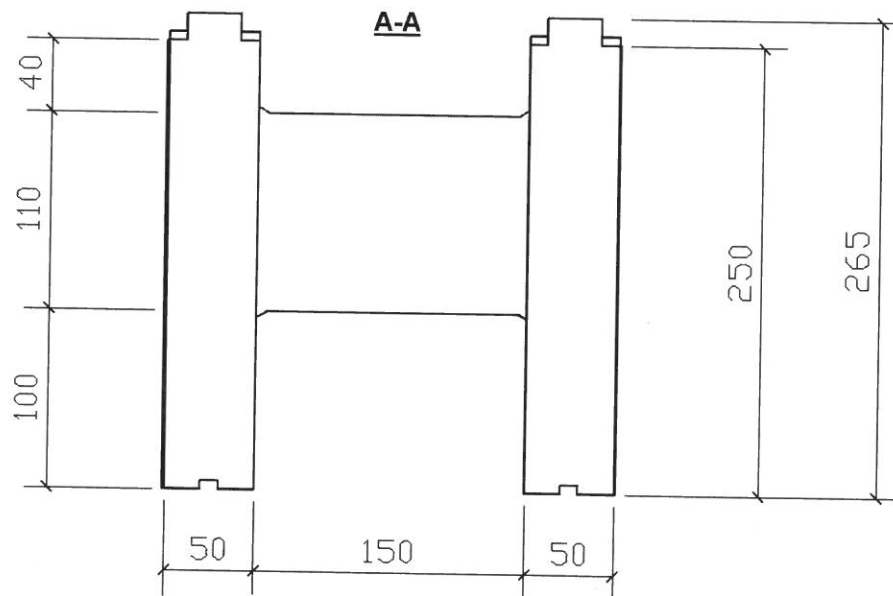
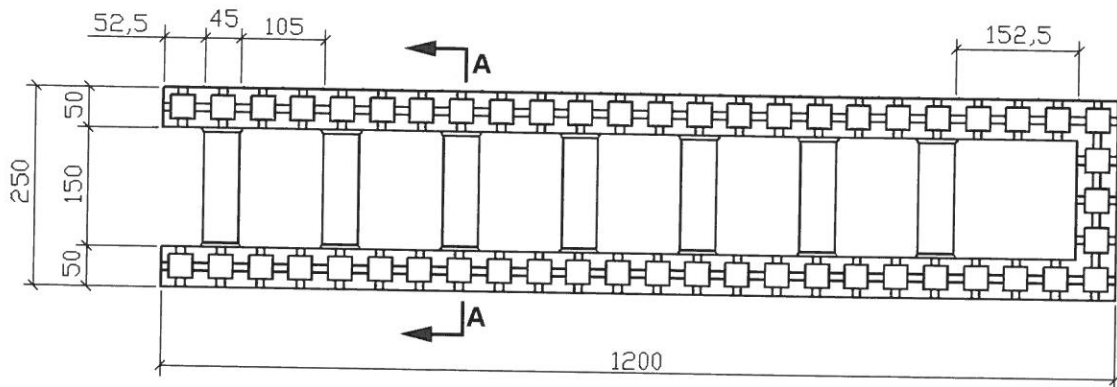

ICF SYSTEM

Thermohouse 250 standard element (view and vertical section)

Annex A22
of European
Technical Assessment
ETA-07/0018

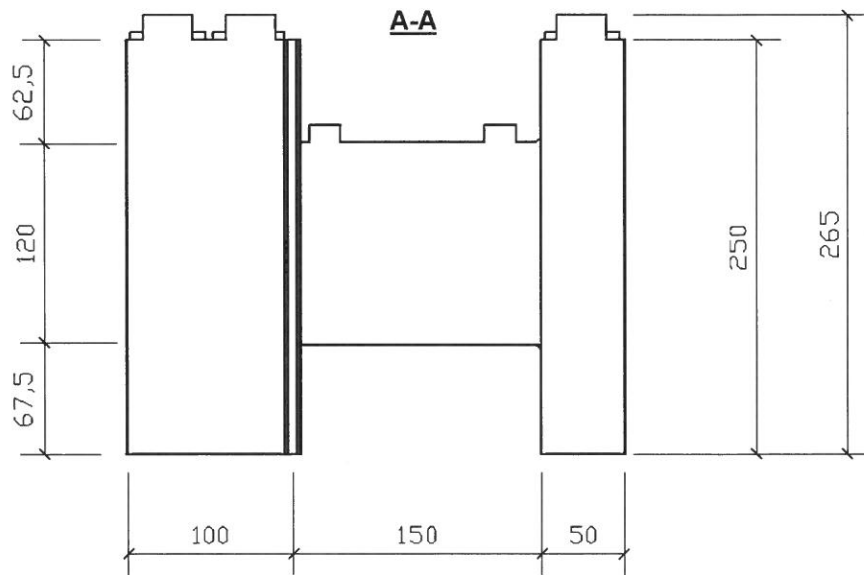
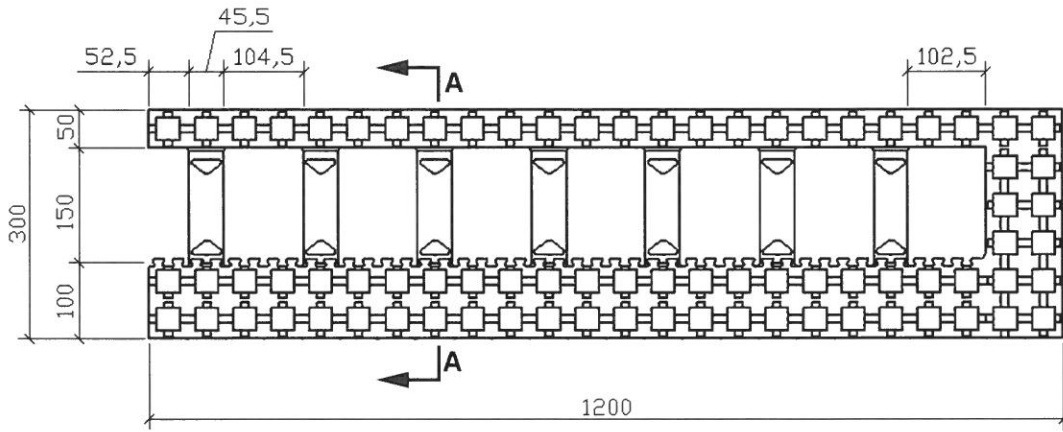

ICF SYSTEM

Thermohouse 300 standard element (view and vertical section)

Annex A23
of European
Technical Assessment
ETA-07/0018

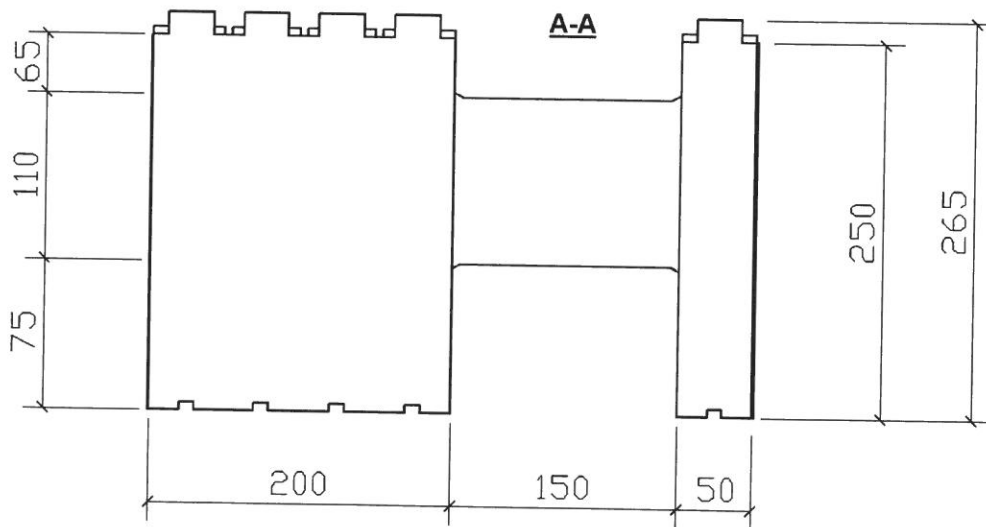
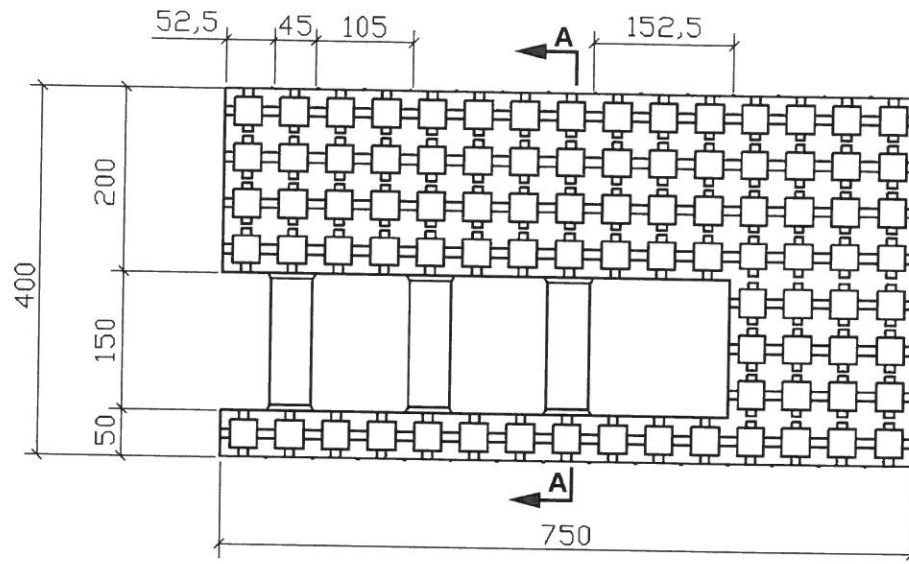

ICF SYSTEM

Thermohouse 400 standard element (view and vertical section)

Annex A24
of European
Technical Assessment
ETA-07/0018

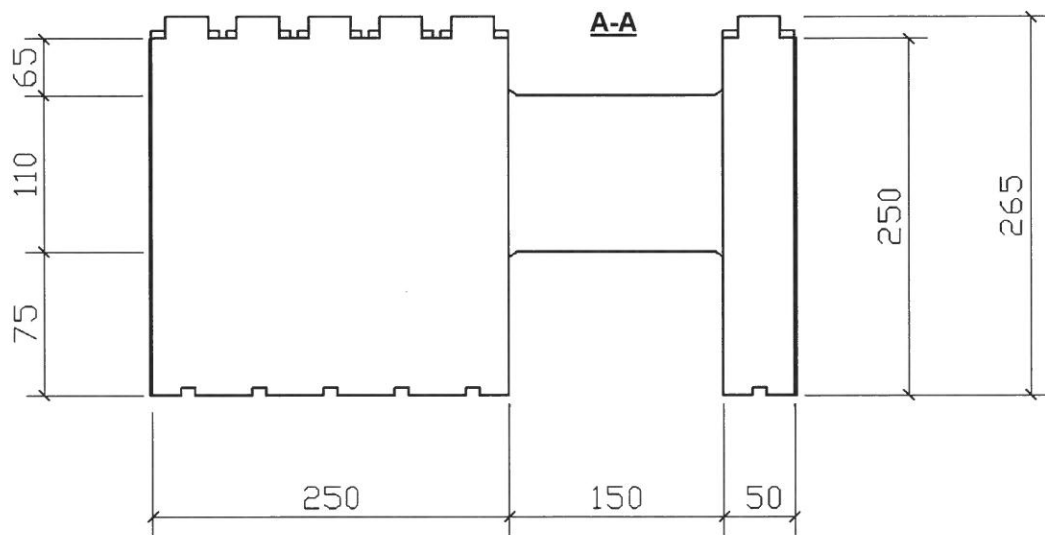
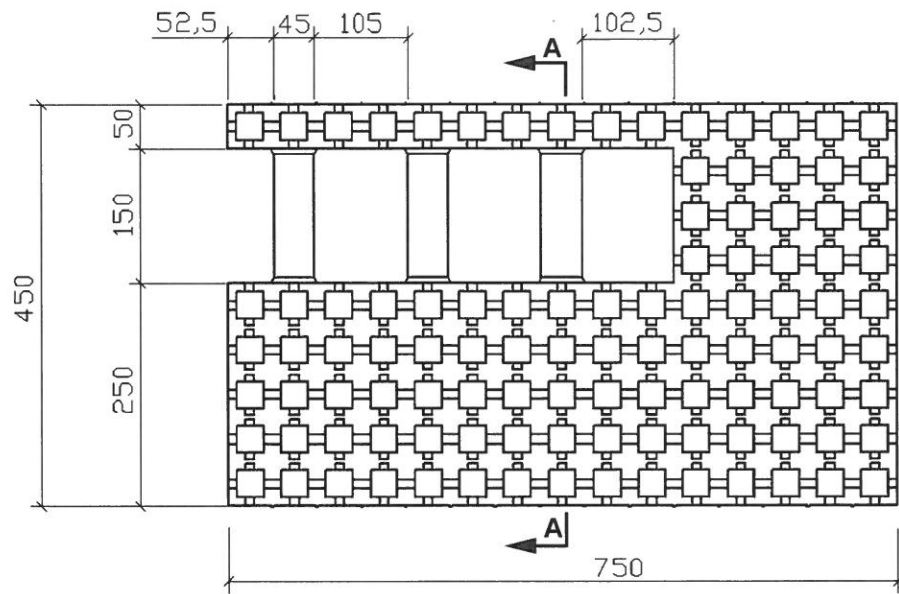

ICF SYSTEM

Thermohouse 450 standard element (view and vertical section)

Annex A25
of European
Technical Assessment
ETA-07/0018

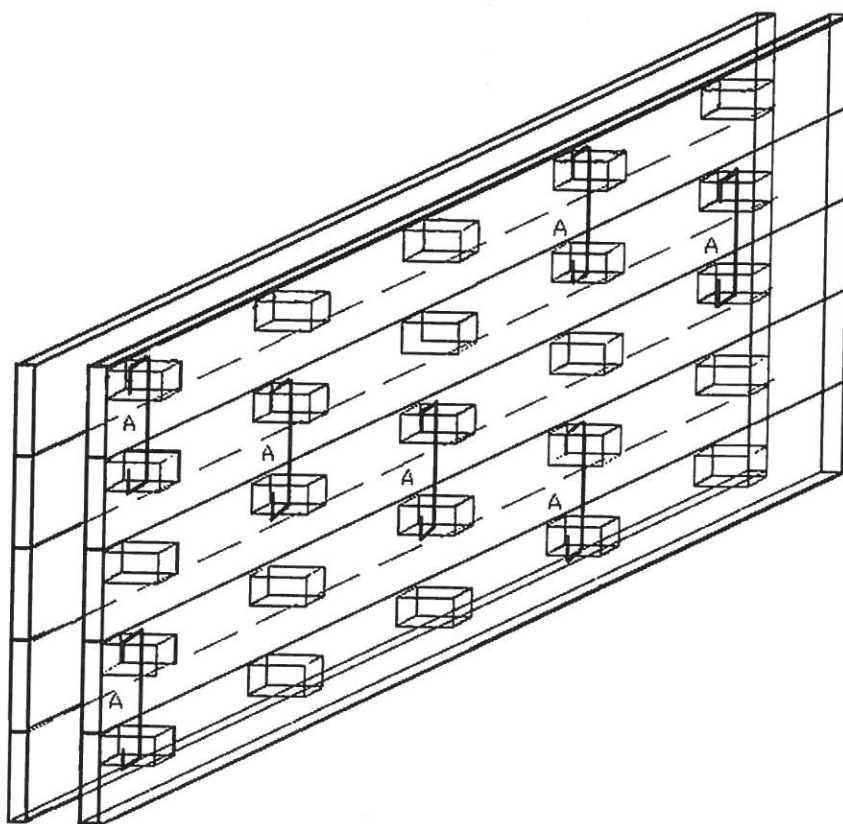
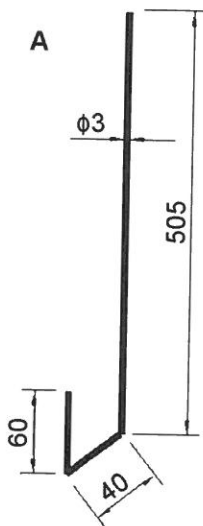

ICF SYSTEM

Clamps made of wire of the diameter $\phi 3$ mm using between two shuttering elements (8 clamps per m^2 of the wall)

Annex A26
of European
Technical Assessment
ETA-07/0018

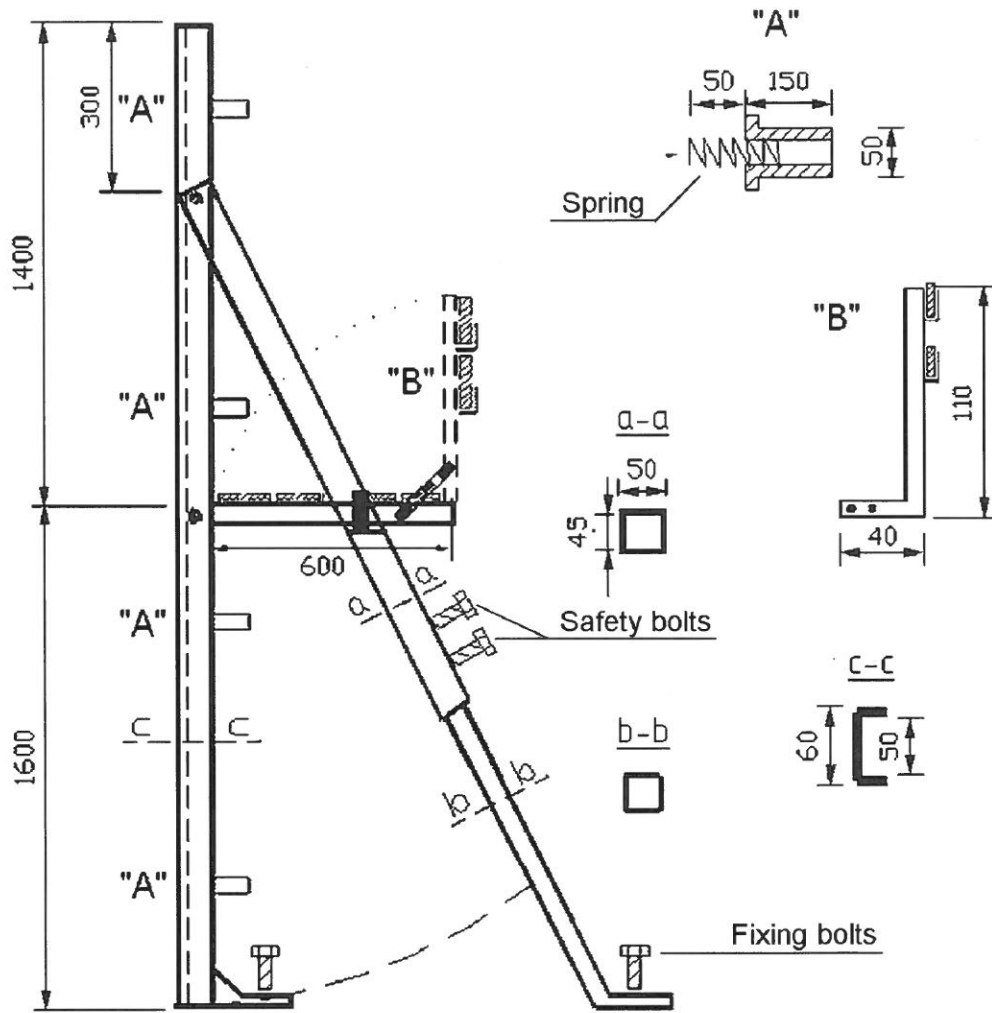

ICF SYSTEM

Bracing supports arranged at a maximum distance of 1,0 m

Annex A27
of European
Technical Assessment
ETA-07/0018

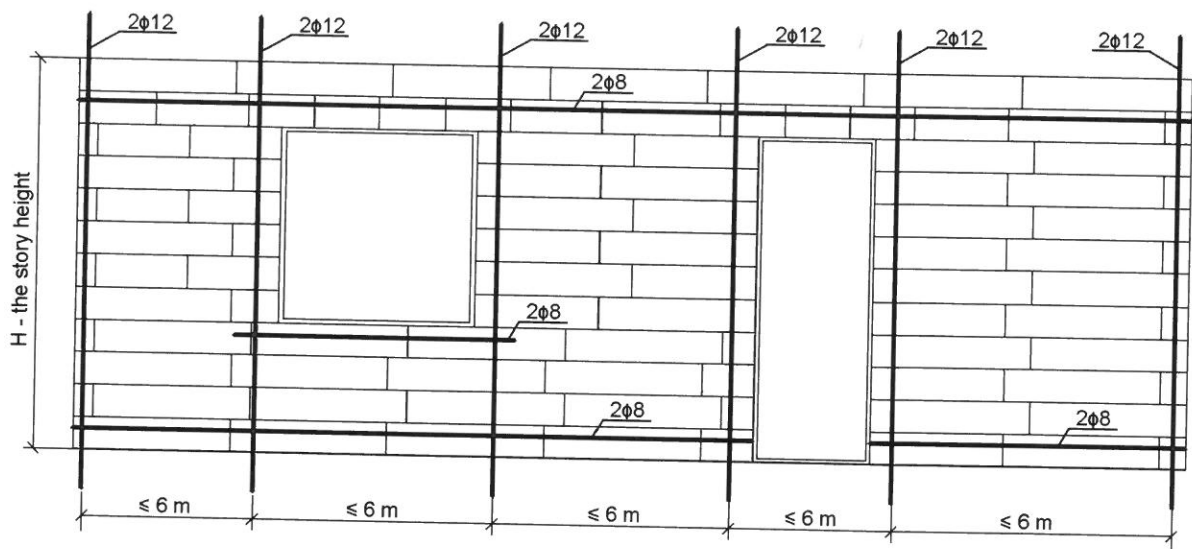

ICF SYSTEM

Minimum necessary steel reinforcement
(apart from the static calculation)

Annex A28
of European
Technical Assessment
ETA-07/0018

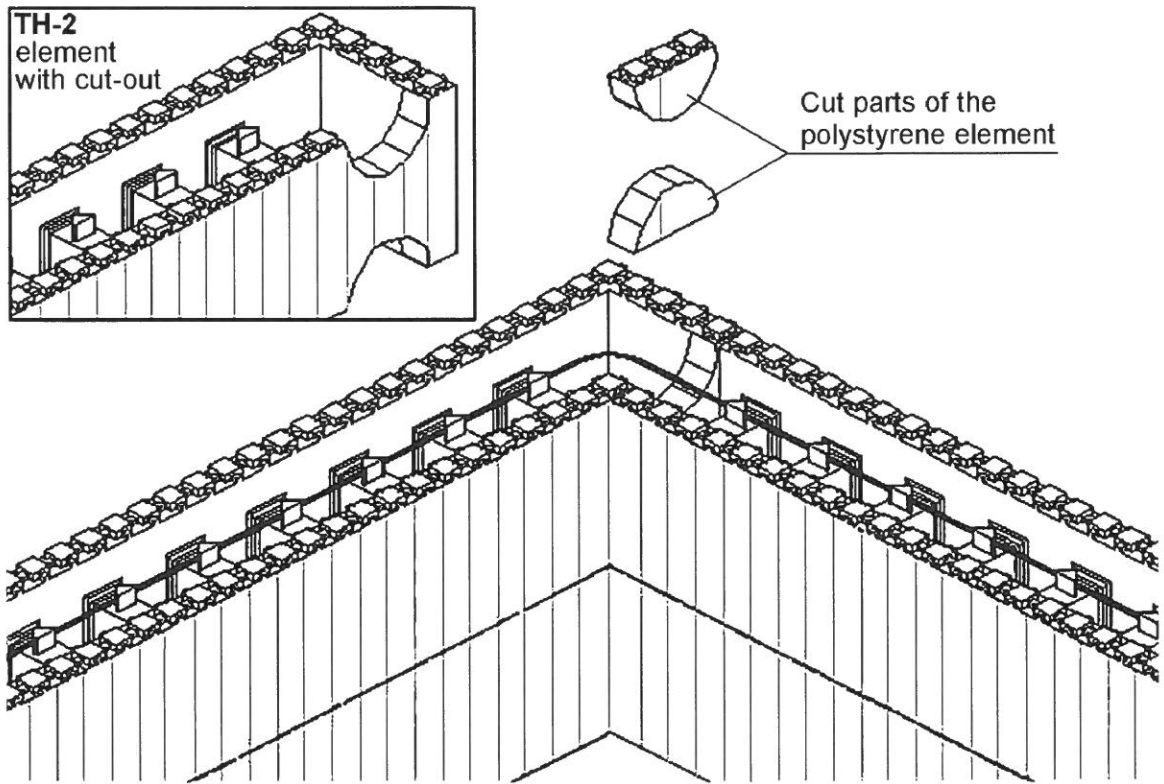

ICF SYSTEM

Construction of 90° corner

Annex A29
of European
Technical Assessment
ETA-07/0018

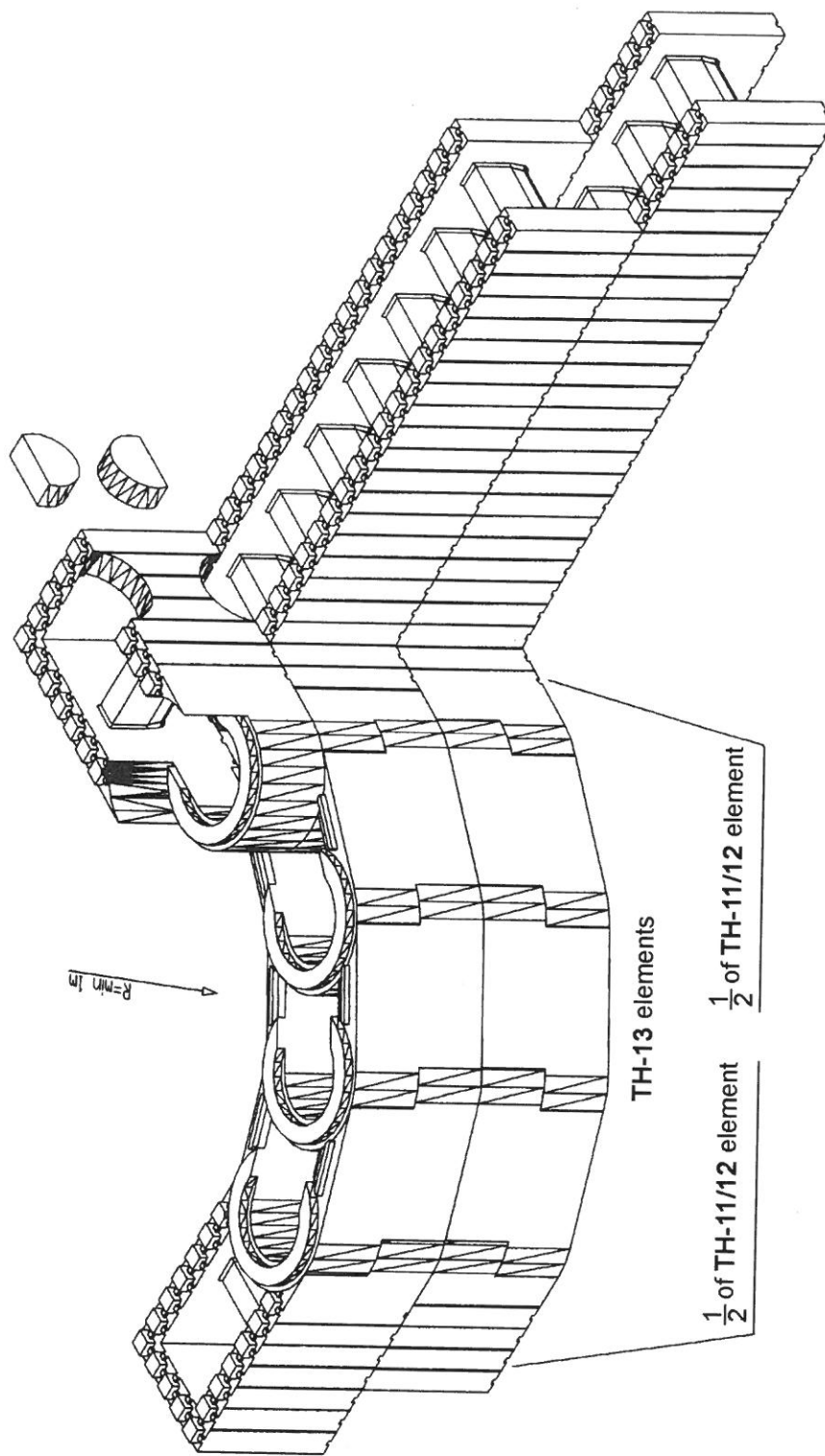

ICF SYSTEM

Construction of curved wall with TH-11/12 and TH-13 hinge elements

Annex A30
of European
Technical Assessment
ETA-07/0018

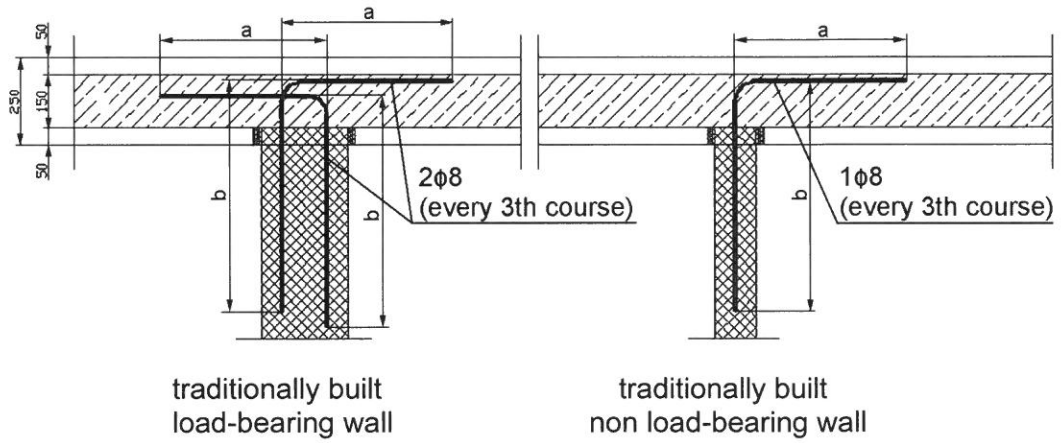
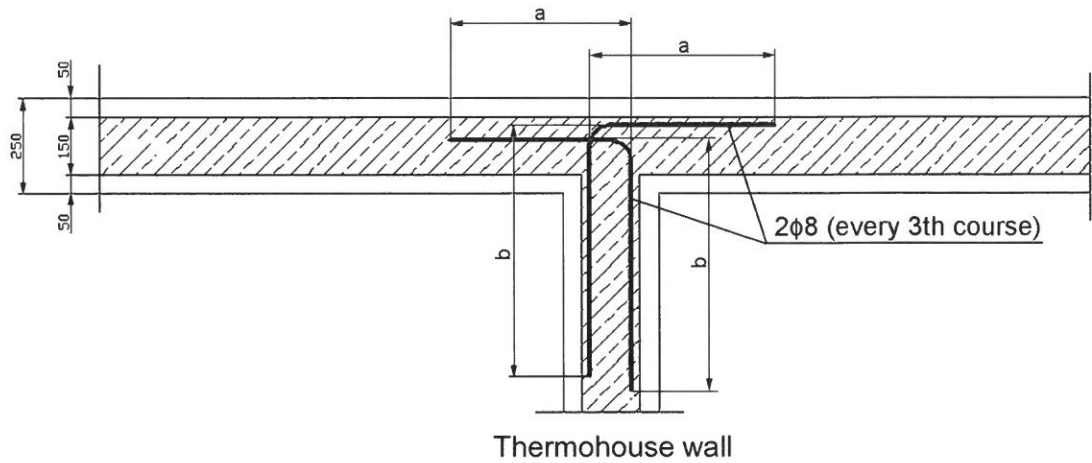

$a - 40 \times d_{\text{steel bar}}$

$b - 50 \times d_{\text{steel bar}}$

ICF SYSTEM

Placement of horizontal reinforcement steel in T-walls

Annex A31
of European
Technical Assessment
ETA-07/0018

1.0. Installation

1.1. General

The manufacturer shall ensure that the requirements in accordance with sections 1, 2 and 3 are made known to those involved in design and execution of construction works. The installation guide is deposited with Instytut Techniki Budowlanej and shall be available at every construction site.

After installation of the shuttering elements the site-mixed or ready mixed concrete is poured in and compacted. In end use conditions concrete walls of a grid type – in case of walls made of elements with expanded polystyrene spacers and continuous type – in case of walls made of elements with steel spacers, of plain or reinforced concrete will be formed according to EN 1992-1-1 or according to corresponding national rules.

1.2. Installation of the shuttering elements

The shuttering elements are put together on site in layers without adhesive. To receive stable floor high formworks the vertical connecting elements (clamps) made of wire of the diameter $\Phi 3$ mm between two shuttering elements have to be used – 8 clamps per m^2 of the wall. The clamps and the method of using them are shown in Annex A26.

According to the installation guide of the ETA-holder in order to keep the walls aligned vertically the bracing are to be used (see Annex A27). The bracing supports are to be arranged at a maximum distance of 1,0 m, to be connected over the entire wall height with the shuttering elements and to be fastened to the floor. They shall be used on one side of the wall only (usually inside).

The necessary steel reinforcement according to static calculation shall be installed. Apart from the static calculation the minimum required steel reinforcement is as following:

- horizontally - 2 $\Phi 8$ mm in the first and last layer of shuttering elements of the storey,
- vertically - 2 $\Phi 12$ mm in wall corners and around openings.

The minimum necessary steel reinforcement and the rules of its installation are shown in Annex A28. Construction of 90° wall corner, construction of curved wall with the hinge elements and placement of horizontal reinforcement steel in T-walls are shown in Annexes A29 to A31.

1.3. Concreting

For the production of normal concrete EN 206-1 shall apply.

In case of walls made of elements with expanded polystyrene spacers the maximum aggregate size shall be 8 mm and the flow class of fresh concrete shall be F5. The concrete shall be compacted by rodding. The maximum aggregate size shall be 8 mm and the flow class of fresh concrete shall be F5. In case of walls made of elements with steel spacers the maximum aggregate size shall be 16 mm and the flow class of fresh concrete shall be higher than or equal to F3. The consistency of concrete on compacting by vibration shall be within the lower consistency range of F3 and on compacting by rodding within the upper consistency range of F3. The concrete shall have rapid or middle strength development according to EN 206-1, Table 12. The concrete may fall freely up to a height of 3 m. Pouring the concrete shall be performed only by persons who were instructed in the works and in the proper handling of the shuttering system. Pouring the concrete shall be performed in layers of approximately 1,0 m at a maximum vertical concreting rate of 3 m^3/h . The requirements of the installation guide of the ETA-holder shall be taken into account during concreting. After concreting the walls may not deviate from the plumb line more than 5 mm per running meter of the wall height.

1.4. Finishing

Walls made of the shuttering kit ICF SYSTEM shall be protected by finishes. The choice of the finishes shall be examined and assessed by the designer case-by-case and depending on the particular use. Finishes are not part of the kit covered by this ETA. Preferably for external surfaces the rendering (base coat + glass fibre mesh + finishing coat) used shall meet the requirements of ETAG 004 "External Thermal Insulation Composite Systems with rendering".

ICF SYSTEM	Annex B1 of European Technical Assessment ETA-07/0018
Installation	

