

TSL-721

wc sensor flush valve kit

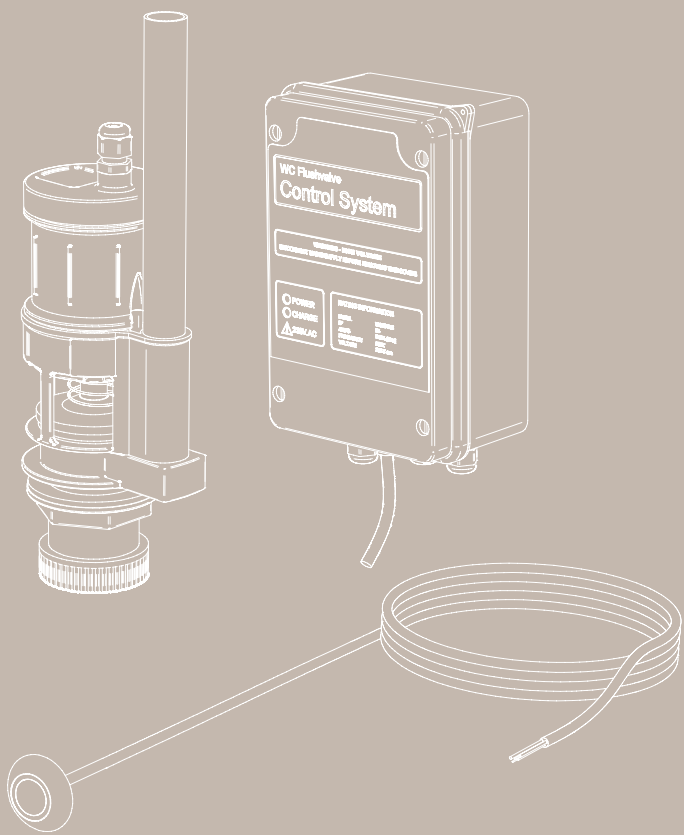

installation + maintenance



contents

3	Box Contents
4	Technical Data
5	Before You Install
6	How to install - Control Box
8	How to Install - Valve
10	How to Install - Sensor
11	How to install - Electrical Connection
13	Commissioning
14	Warranty
15	Contact Details

box contents

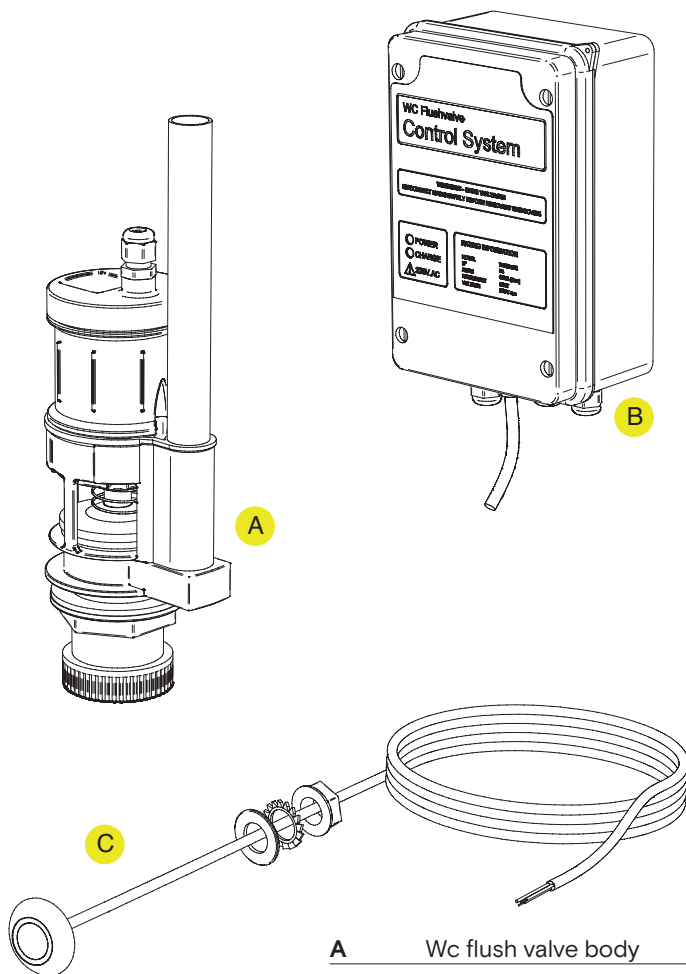

- A Wc flush valve body
- B Control enclosure
- C Wave-on sensor

technical data

Finishes (Bezel only)	CS (Brushed Stainless Steel)
	CP (Brushed Copper)
	BK (Brushed Black)
	BR (Brushed Brass)
	BZ (Brushed Bronze)
Weight	2.16Kg
Material - sensor	ABS Plastic
Material - bezel	AISI304 Stainless steel
Sensor activation	IR user-activated
Power supply	220 – 240V AC
Control	12V DC (integral transformer)
Sensor cable length	3m
Flush valve cable length	2m
Water connection	1 ½" BSP connection to WC flush pipe
Flush volume	Preset 4 litres (flow time can be adjusted on installation)
Ingress Protection rating	IP54
Warranty	12 months from date of purchase

before you install

- + It is recommended that the electrical part of the installation be carried out by a qualified electrician, in accordance with the current local regulations in force. It is also recommended that any plumbing is carried out by a qualified plumber.
- + The flush valve kit is a sophisticated electronic device and must be installed as described so that it operates correctly.
- + If the flush valve is to be used by persons (including children) with limited capabilities, or lack of experience and knowledge, adequate training must be given concerning use of the unit by person responsible for their safety.

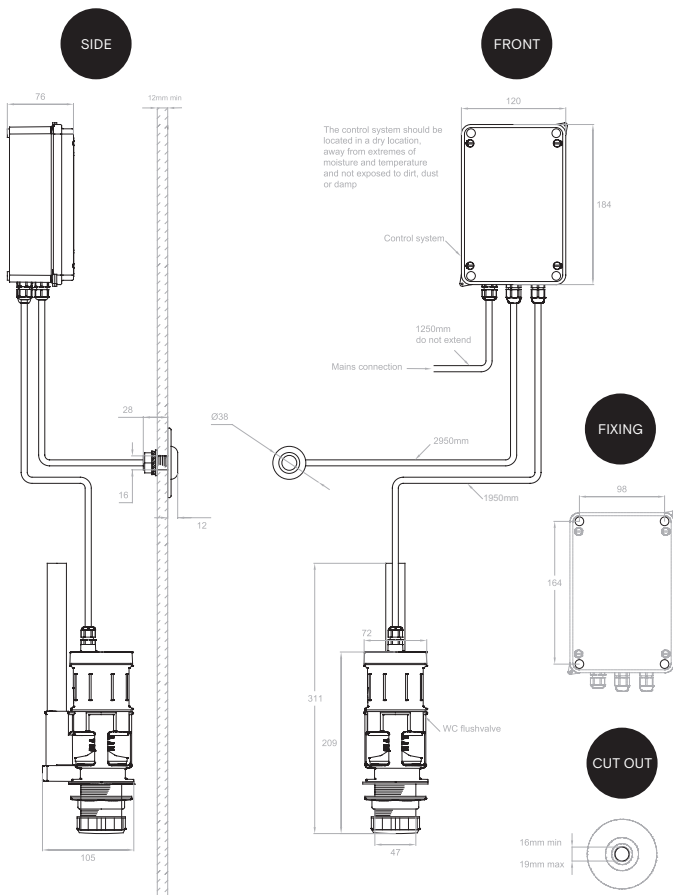

how to install – control box

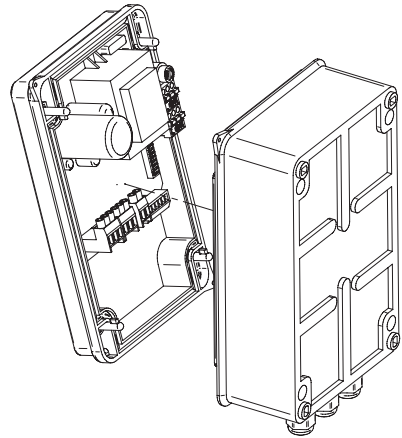
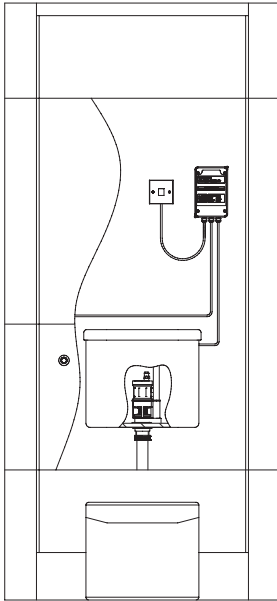

Location

- + The controller should be mounted in a dry location, away from extremes of moisture and temperature, and not exposed to dirt, dust or damp.
- + The unit must be accessible for both initial installation, commissioning and ongoing maintenance. Secure access areas and service ducts are recommended. The controller is not designed for direct surface mounting onto washroom walls.
- + Supply cable routes to the controller from the mains power supply should also be planned at this stage

1

Remove cover of control box to expose the fixing points.

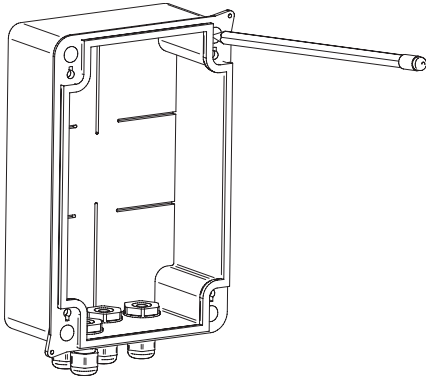

2

Drill through the marked areas away from the wall to avoid dust entering the enclosure, then hold control box against the wall and mark the fixings points on the wall. Fix to the wall with appropriate fixings for the wall substrate.

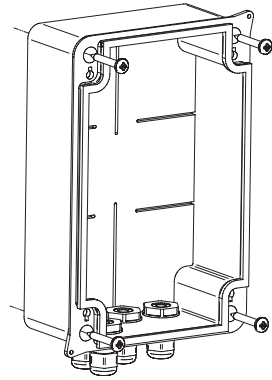

3

Securely mount the control box in a vertical orientation (with the cable entries at the bottom). This must be no more than 2 metres from the sensor.

NB The cable length to the flush-valve is 2 metres, and to the sensor is 3 metres

how to install - valve

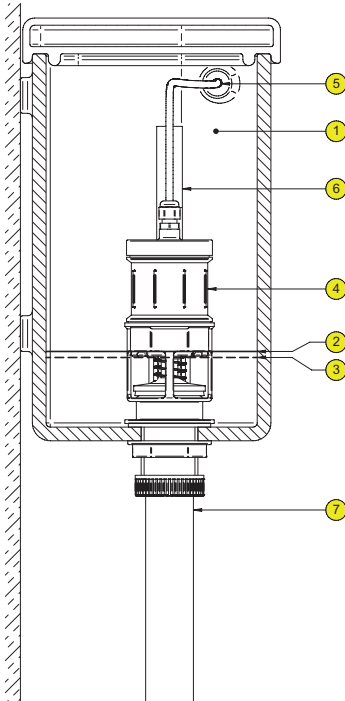

1. Max water level
2. Minimum water level
3. Top of flush-valve window
4. Flush-valve body
5. Sensor cable inlet
6. Overflow pipe

1

Ensure the inside of the cistern is clean, ensuring the area around the seals are free from any debris. Apply sealant tape to thread on flush valve and fit rubber seal provided.

3

Route and secure the valve cable to a convenient position for the control box. (within 2 metres)

2

Install the flush-valve in the cistern, secure with the back-nut provided and connect the flush-pipe. Trim the valve's integral overflow pipe so that it is at least 20mm lower than the cistern overflow.

4

Connect the water supply to the cistern, allow to fill and check for any leaks.

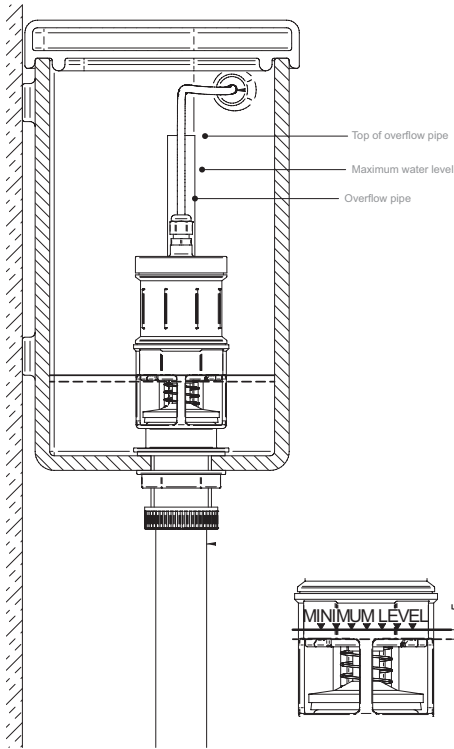

Maximum Water Level

- + The maximum water level must be below the top of the overflow pipe. This would normally be controlled by an inlet valve float switch. It is recommended that the maximum water level is set at this stage.

Minimum Water Level

- + The minimum water level after the flush cycle has completed must be 5mm above the flush valve window. It is critical that the minimum water level does not fall below this level, otherwise the valve operation will be more audible, and there is a risk of damage to the valve.
- + The minimum water level is controlled by the flush timing settings, as detailed in the Commissioning section (page 13). It is recommended that the minimum water level is set at the commissioning stage of installation.

how to install – sensor

Location

- + Care must be taken when positioning the sensor to ensure ease of use, and that general WC cubicle occupancy could not accidentally cause the valve to operate

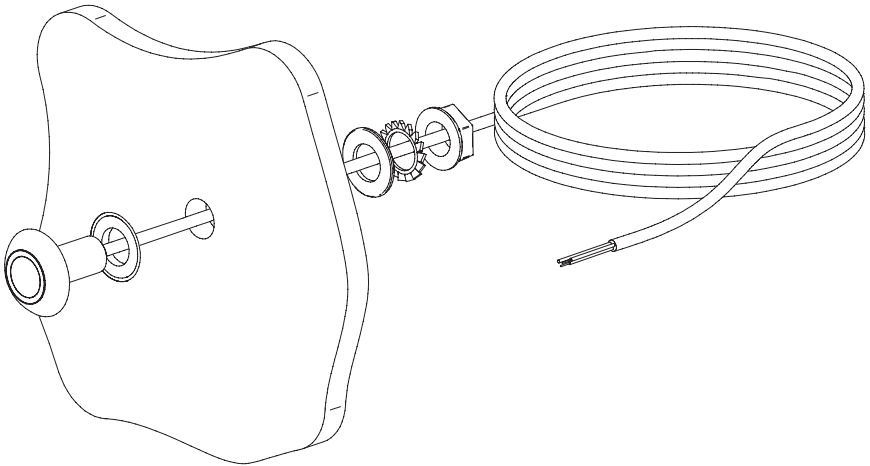

- + The sensor must be fitted on a vertical surface less than 2 metres from the controller, through a 17-25mm diameter pre-drilled hole.
- + Secure the sensor to the wall using the nut and washers supplied.

electrical connection

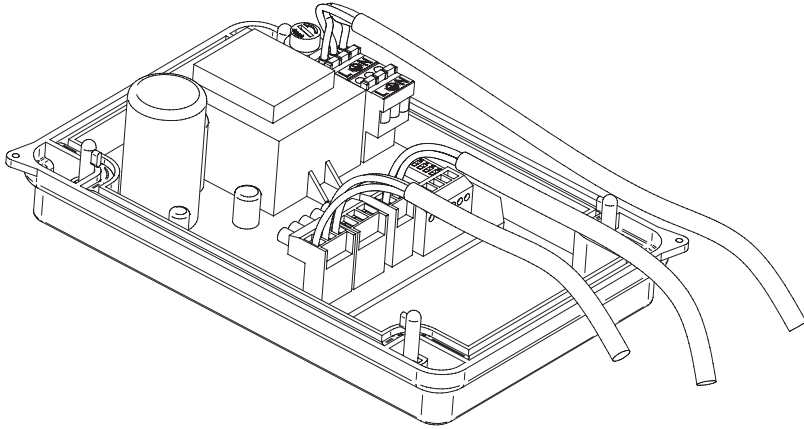

Power cable

- + The flush-valve cable should be trimmed to length and connected to the control box.
- + Connect the Blue wire to the Blue Terminal, and the Brown wire to the Brown terminal, ensuring that the cable is clean and dry prior to connection.
- + When each plug has been connected, the cables can be pulled back through the cable glands and the plug re-connected to the corresponding socket. Cables should not be left too taut or slack.

Sensor cable connection

- + The control system has two connections for sensors; one for half-flush settings and the other for full flush. The sensor can be fitted to either of the connections, or 2 sensors could be connected allowing both half- and full flush options to be utilised.
- + When each plug has been connected, the cables can be pulled back through the cable glands and the plug re-connected to the corresponding socket. Cables should not be left too taut or slack.

commissioning

Minimum Water Level

The minimum water level after the flush cycle has completed must be 5mm above the flush valve window. It is critical that the minimum water level does not fall below this level, otherwise the valve operation will be more audible, and there is a risk of damage to the valve.

The minimum water level is controlled by the flush timing settings.

Adjust the Time Settings

1. The settings are adjusted by altering the switches on the 'Flush Timing bar' on the control box cover.

Switch 1 = 3 second flush

Switch 2 = 2 second flush

Switch 3 = 1 second flush

Switch 4 = 0.5 second flush

Switch 5 = 0.25 second flush

The total flush time is determined as the sum of the times for each switch that is set to the 'ON' position.

The default setting is Switches # 1 and #3 are set to 'ON' giving a 4 second flush time. Settings below 1 second will automatically default to 1 second.

2. If the sensor cable is connected to the 'Half-Flush' terminal in the control box, then all flush timings will be half the time as determined on the 'Flush Timing Bar'

Start-up

1. When the flush valve and controller is first powered up, the LED power indicator on the front of the controller will illuminate.
2. The LED charge indicator will start up green, then change to red for the time that is set on the 'Flush Timing Bar'

Green	Normal
Red	Charging
3. When the red LED turns off for the second time, the system is ready for use. The system is now active and monitoring sensor inputs.
4. Upon a signal from the sensor, the valve will lift for the pre-set time. When the valve then drops, the red LED will illuminate for the charging period. No operation is possible when the system is recharging ie when the LED is red.
5. The Flushvalve system is now ready for use, and installation is complete.

contact



General information

info@thesplashlab.com

+44 (0) 161 482 7000

Technical support

technical@thesplashlab.com

For further contact information visit:

www.thesplashlab.com

