

Monolith 200

Wall Mounted
Basin

The monolith 200 is a slim wall mounted, **modular** basin system, crafted from solid-surface. Available in both standard and bespoke lengths; and in a wide range of colours the Monolith 200 is well suited to any washroom

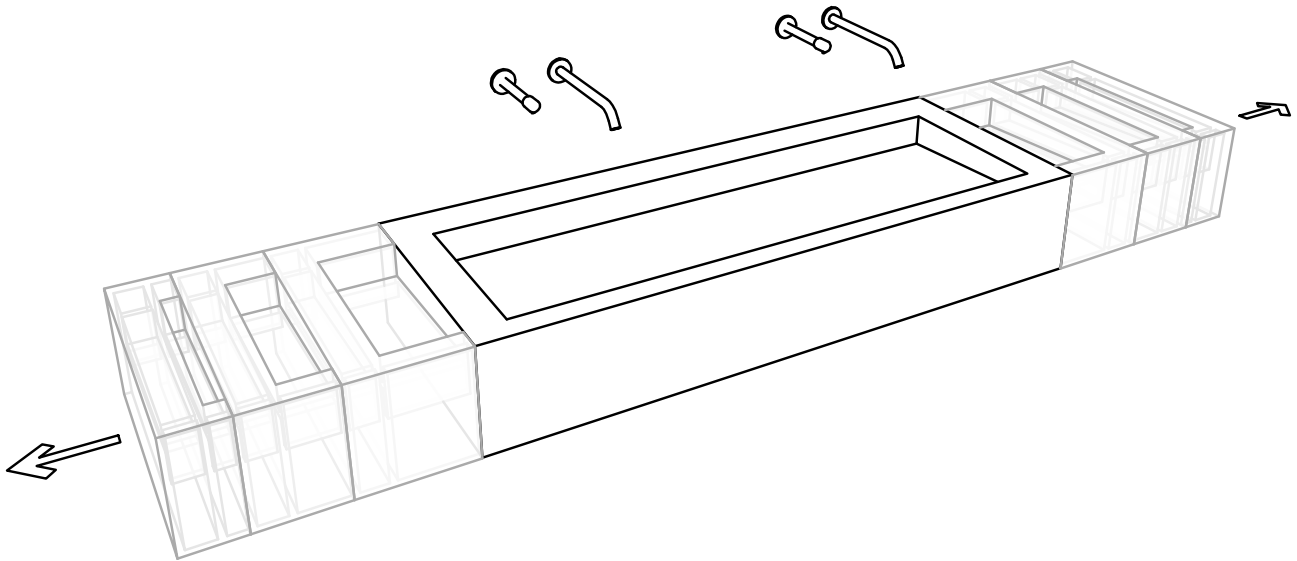

**Taps and Soap dispensers sold separately*

STANDARD DIMENSIONS

LENGTH (mm)	DEPTH (mm)	USERS	PRODUCT CODES	WEIGHT (KG)
600	300	1	TSL-Mono.600.300.200	11
600	450	1	TSL-Mono.600.450.200	16
600	600	1	TSL-Mono.600.600.200	21
1200	300	2	TSL-Mono.1200.300.200	19
1200	450	2	TSL-Mono.1200.450.200	26
1200	600	2	TSL-Mono.1200.600.200	33
1800	300	3	TSL-Mono.1800.300.200	27
1800	450	3	TSL-Mono.1800.450.200	36
1800	600	3	TSL-Mono.1800.600.200	45
2400	300	4	TSL-Mono.2400.300.200	35
2400	450	4	TSL-Mono.2400.450.200	46
2400	600	4	TSL-Mono.2400.600.200	57
3000	300	5	TSL-Mono.3000.300.200	36
3000	450	5	TSL-Mono.3000.450.200	50
3000	600	5	TSL-Mono.3000.600.200	71

SYSTEM OVERVIEW

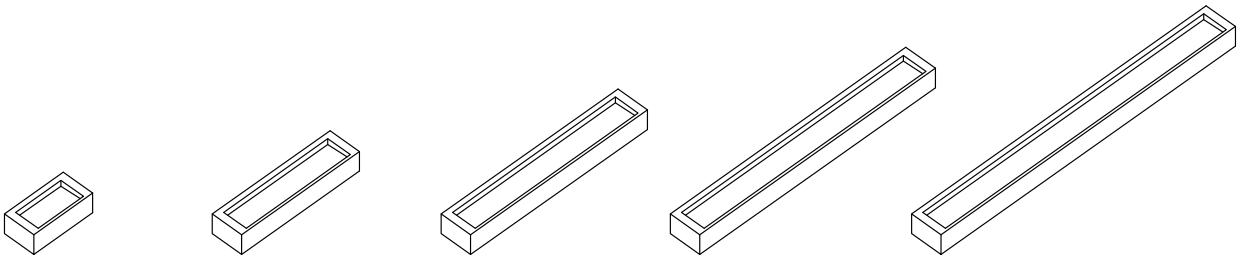
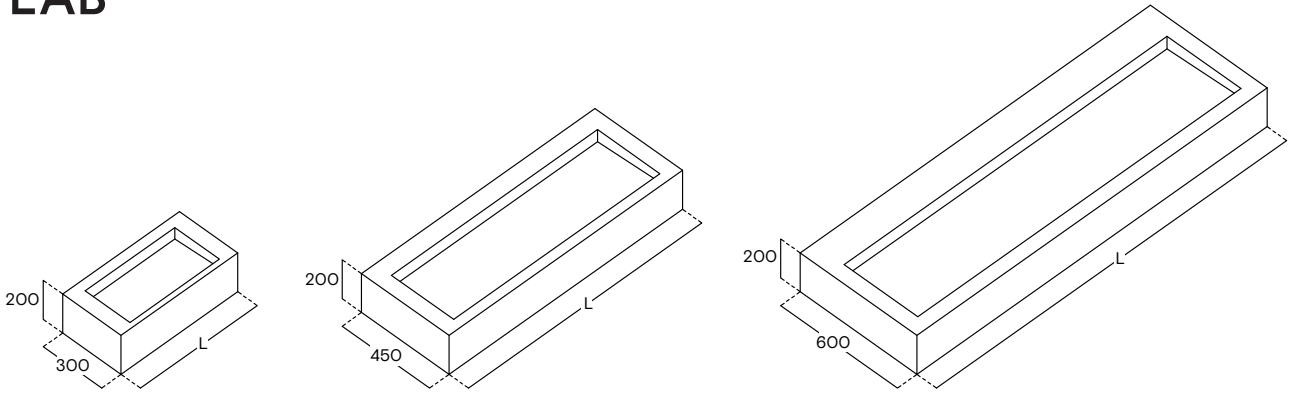

TSL-Mono.600.30\$.200
H 200
D 300
L 600

TSL-Mono.1200.300.200
H 200
D 300
L 1200

TSL-Mono.1800.300.200
H 200
D 300
L 1800

TSL-Mono.2400.300.200
H 200
D 300
L 2400

TSL-Mono.3000.300.200
H 200
D 300
L 3000

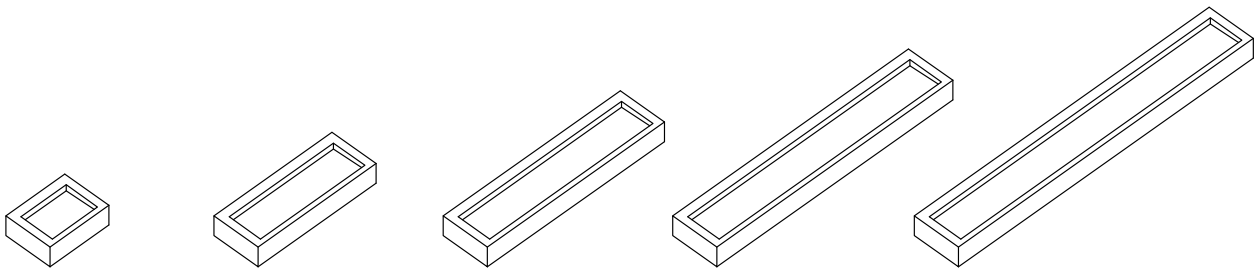

TSL-Mono.600.45\$.200
H 200
D 450
L 600

TSL-Mono.1200.45\$.200
H 200
D 450
L 1200

TSL-Mono.1800.450.200
H 200
D 450
L 1800

TSL-Mono.2400.450.200
H 200
D 450
L 2400

TSL-Mono.3000.450.200
H 200
D 450
L 3000

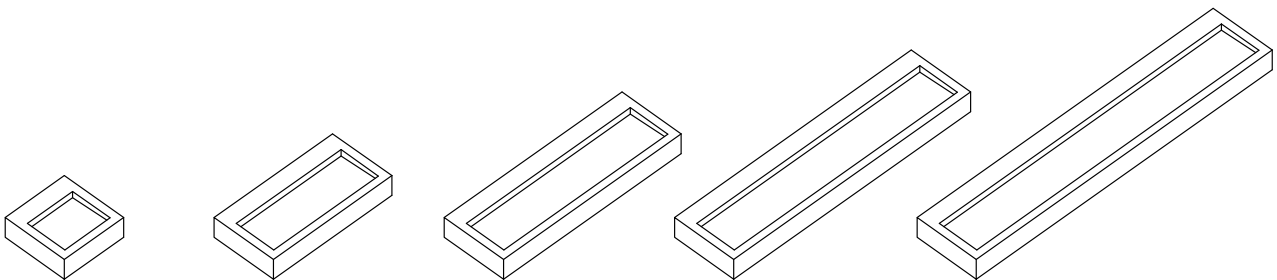

TSL-Mono.600.600.200
H 200
D 600
L 600

TSL-Mono.1200.600.200
H 200
D 600
L 1200

TSL-Mono.1800.600.200
H 200
D 600
L 1800

TSL-Mono.2400.600.200
H 200
D 600
L 2400

TSL-Mono.3000.600.200
H 200
D 600
L 3000

TECHNICAL DATA

Warranty	10 years from date of purchase (terms and conditions apply)
Material	Solid surface
Support Brackets	Powder-coated steel – Refer to Installation manual for spacing and setting out
Colours	Refer to colour range

INSTALLATION GUIDELINES

Wall construction	Brackets included. Installer should ascertain that wall construction is sufficiently designed to support the Monolith.
Fixed height	See Drawing
Wall Fixings	Must be fixed to a suitable wall substrate to allow for the correct use of the Monolith. The Splash Lab recommend that installers contact a fixings specialist for advice to ensure the correct fixings are used for the location. Wall fixings are not included with the Monolith.
Plumbing	Connection to 1 ¼” waste outlet required. (one connection per user) Installer to provide water for taps. See separate datasheet for The Splash Lab sensor taps.
Access requirements	Solenoid and isolation valves must be accessible for initial installation & commissioning and for ongoing and routine maintenance.

ACCREDITATIONS

Material	Solid Surface	Pending
----------	---------------	---------

RELATED PRODUCTS

Sensor tap	TSL-880
Soap dispenser	TSL-470

RELATED PRODUCTS

Installation and maintenance manual	email: technical@thesplashlab.com
Warranty document	email: technical@thesplashlab.com



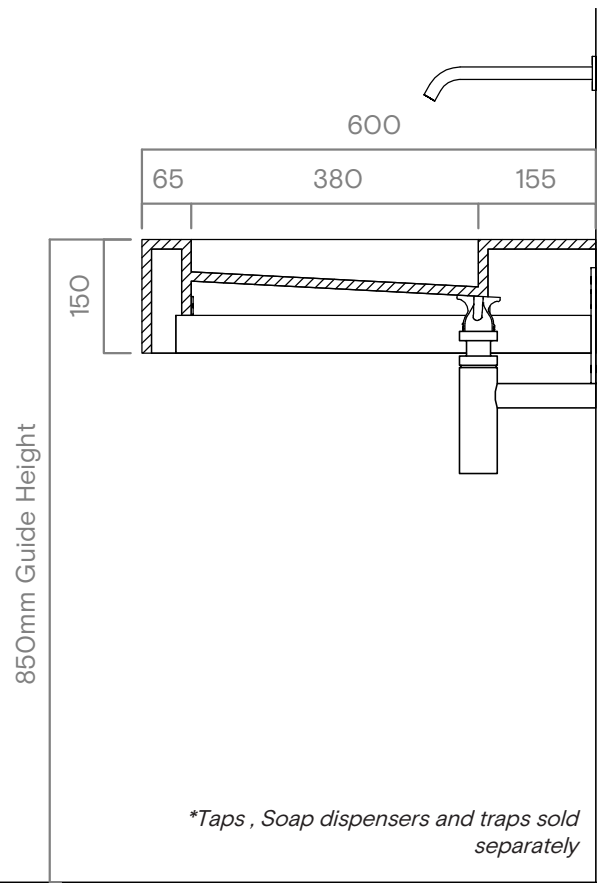
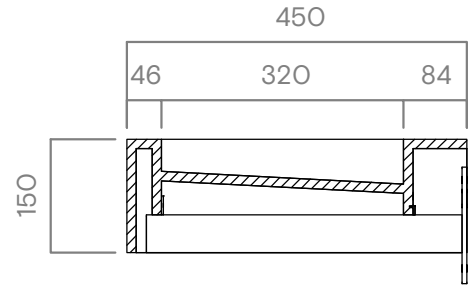
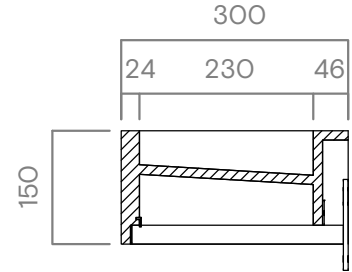
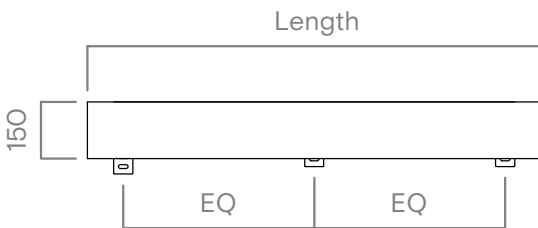
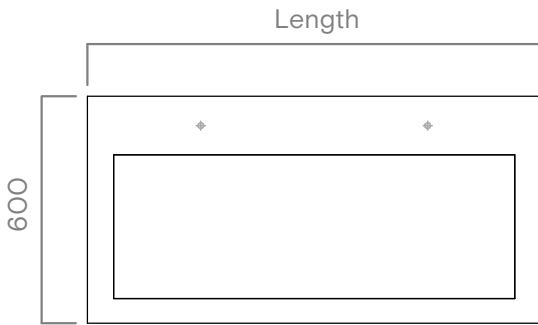
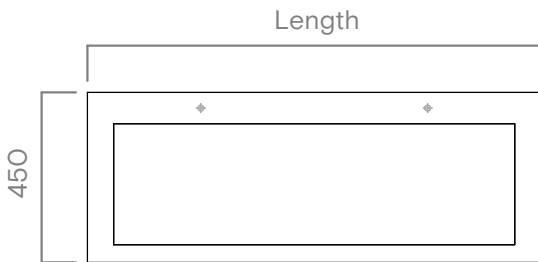
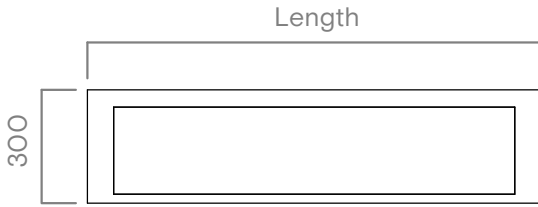

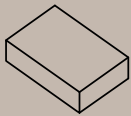
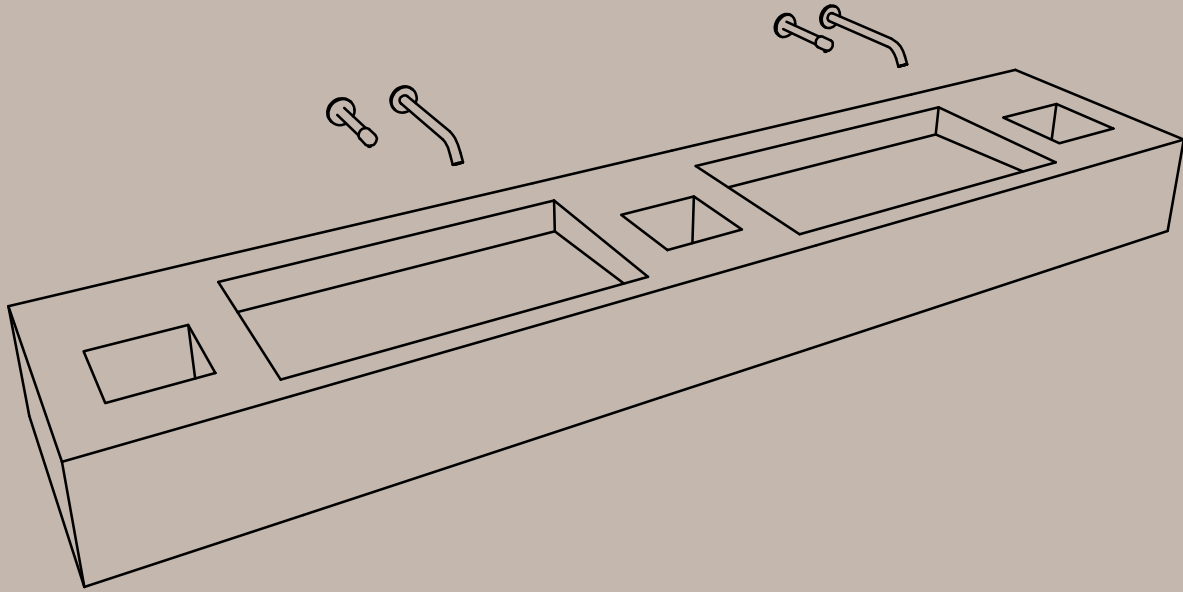

Monolith Divider

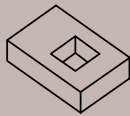

Monolith Divider with
Bin Chute

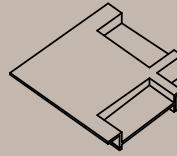

Monolith Corner

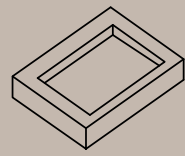

Monolith DDA/Low Level

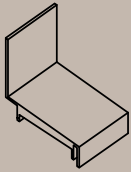

Monolith Divider
+ splashback

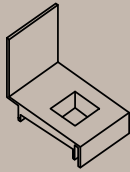

Monolith Divider with
Bin Chute
+ splashback

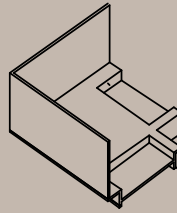

Monolith Corner
+ splashback

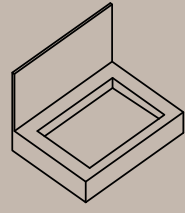

Monolith DDA/Low Level
+ splashback

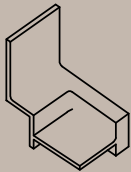

Monolith covered
corners

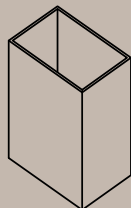

Monolith Leg

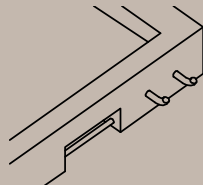

Monolith Features



TSL Monolith
Recessed Branding
and signage



TSL Monolith panels,
doors and skirtings