

Installation Guide | the Plateau Rooflight

> a roof window range suitable for pitched roofs between 3° and 20°

> insulated kerb upstand (warm roof)

July 2013



the Rooflight Company
The Professionals' Choice

WELCOME

Thank you for choosing the Plateau Rooflight. We are sure that the Plateau Rooflight will provide a high-quality finishing touch to your project. This guide is intended to assist building contractors and homeowners in receiving, handling and installing the Plateau Rooflight. Please take the time to read and carefully follow these instructions. Before you start your installation, please refer to the '**IMPORTANT INFORMATION**' section at the back of this installation guide.

GENERAL

Please note: the minimum roof angle at which the Plateau Rooflight can be installed is 3 degrees (depending upon size).

Please note: the maximum roof angle at which the Plateau Rooflight can be installed is 20 degrees

Please note: the following installation details pertain to WARM ROOF LEAD CONSTRUCTION TYPE, installed on a structural kerb. Some installation details may vary depending on the roof construction and type of roof being used. Always view this manual in conjunction with the cross sectional installation details relevant to your project. See Section 8 (Pages 14&15) 'Suggested installation details' towards the back of this manual.

Please note: The model you have purchased may vary in size and orientation from the one used in the images throughout this manual.

In order to install the Plateau Rooflight you will need to know:

- ▶ The Plateau Rooflight model to be installed.

TEXT- Highlighted in **BOLD** indicates a point of special importance.

**PPE NOTE**

The images in this manual are intended to aid installation and where required the installer must use suitable PPE (which may not be shown) and abide by the applicable Health & Safety requirements. It is assumed that suitable method statements and risk assessments will be undertaken prior to installation.

▼ CONTENTS**▼ PAGE**

SECTION 1 - How to use this manual	2
SECTION 2 - Before you get started	4
SECTION 3 - Prior to installation	6
SECTION 4 - Structural opening sizes	7
SECTION 5 - Preparing the roof	9
SECTION 6 - Installing the roof window	11
SECTION 7 - Finishing the interior	12
SECTION 8 - Installing the ironmongery	14
SECTION 9 - Suggested installation details	20
SECTION 10 - Important Information	21

SECTION 2 - Before you get started

- > Contents of the box / pallet
- > Parts List

CONTENTS OF THE BOX / PALLET

> Plateau Rooflight

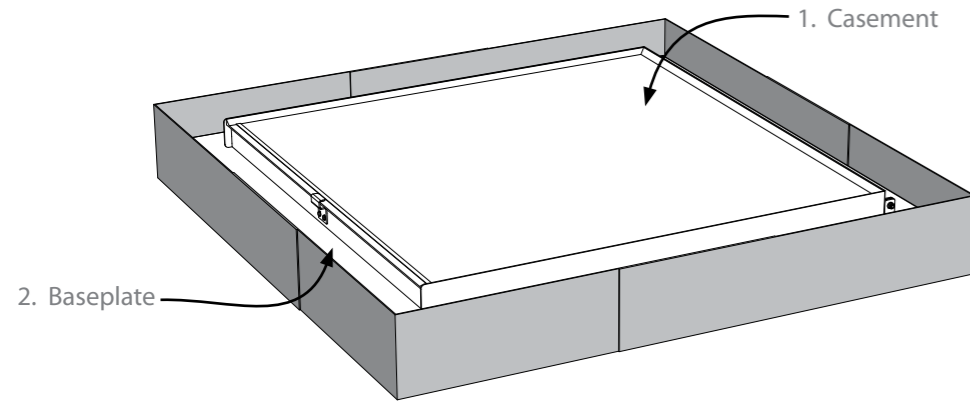

> Fixing pack

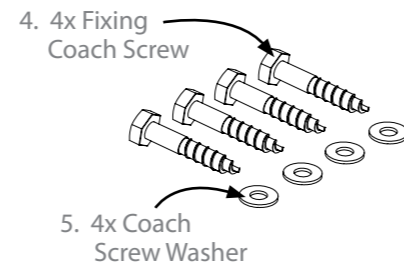

PARTS LIST

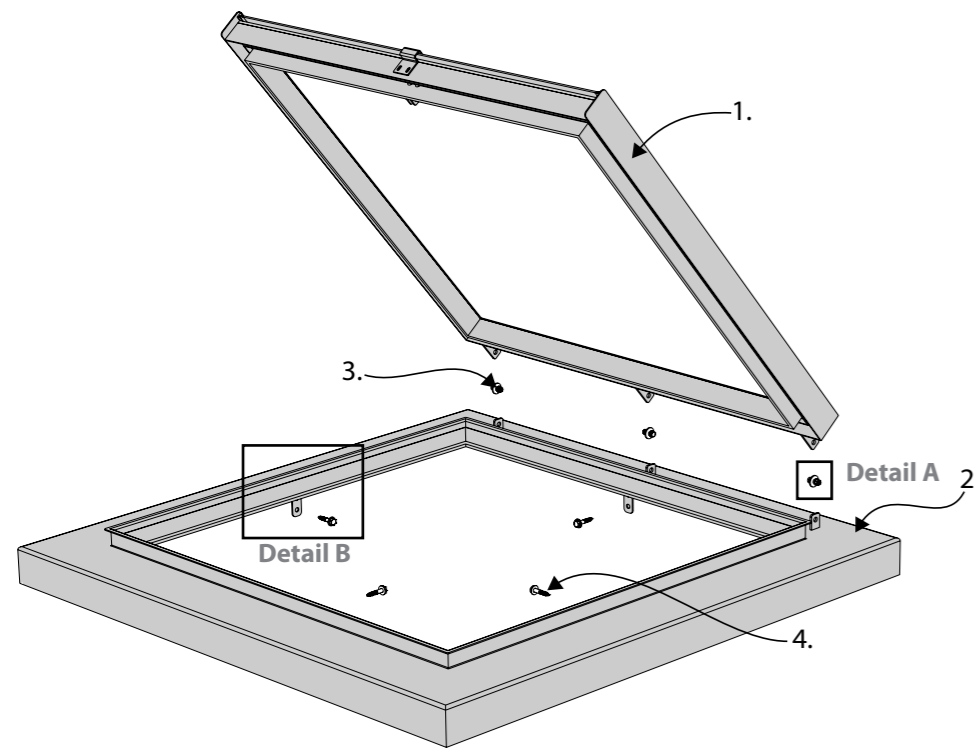

Part Number	Description	Quantity
1	Casement	1
2	Baseplate	1
3	Hinge & Fixings.....	Various
4	Fixing coach screw	4
5	Coach screw washer.....	4

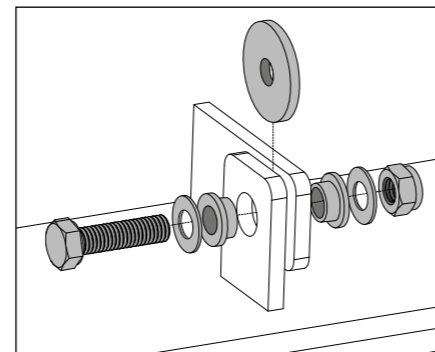

Detail A

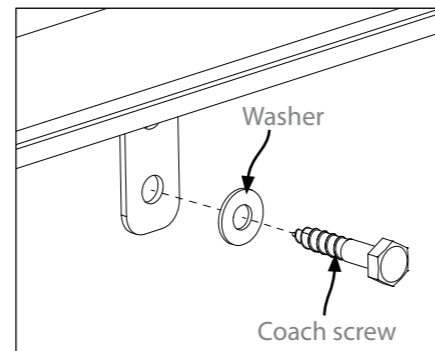

Detail B

NOTE: Please refer to separate manuals for installation of ironmongery/motors/fixing bracket/blinds.

SECTION 2 - Before you get started

- > Receiving the roof window
- > Transport & storage

SINGLE ROOF WINDOW AS DELIVERED *

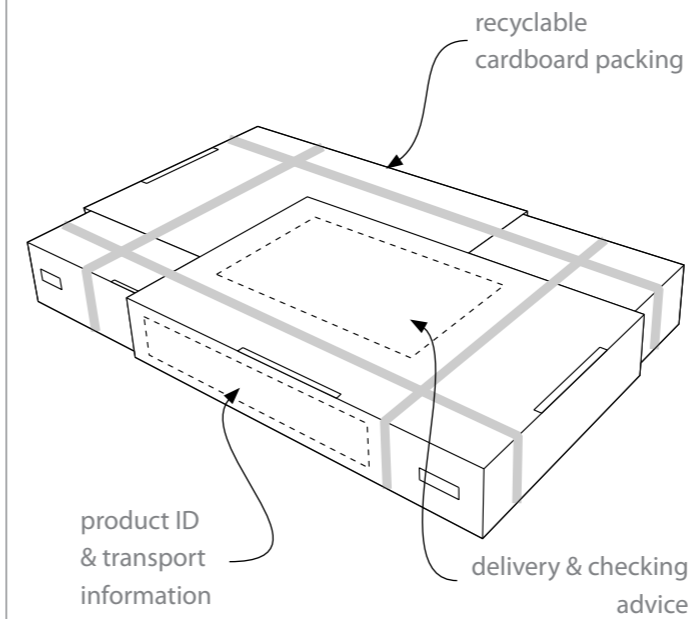

RECEIVING THE ROOF WINDOW

We recommend that the roof window packaging is temporarily opened to allow inspection of the goods for damage. Follow the instructions on the delivery checking and advice label.

- ▶ Once the roof window has been checked, repackage it in the original packaging for safe storage until the roof window is to be installed.

* Large size roof windows may be delivered 'palletised' and not 'boxed' as shown here

TRANSPORT & STORAGE

- ▶ Keep the roof window in its original packaging and store off the ground in a secure covered dry place until it is required for installation.
- ▶ When transporting the roof window in its box, carry the box by lifting it from the underside rather than lifting by its strapping.

! Only carry the box if the banding is attached in its original condition. Do not carry by the box if the nylon banding has been cut or appears in any way damaged.

- ▶ Do **NOT** stack multiple units.
- ▶ Only remove the roof window from its packaging when it is required for installation.
- ▶ Once unpacked carry the roof window by lifting it from the underside of the baseplate.
- ▶ Mark the original box with the window number/location and keep all accessories and linings in the original box until they are required. When the installation is complete and all accessories/linings are used, recycle all of the packaging materials.

SECTION 3 - Prior to installation

> Type of roof / pitch

This installation manual is intended for insulated kerb upstands (warm roof) only. In order to determine if this manual is applicable to your project, please review the following:

WARM OR COLD ROOF CONSTRUCTION TYPE

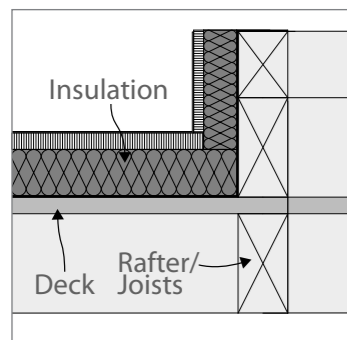

Warm roof

In a warm roof construction, the insulation is positioned directly under the external waterproofing above the rafters/ joists.

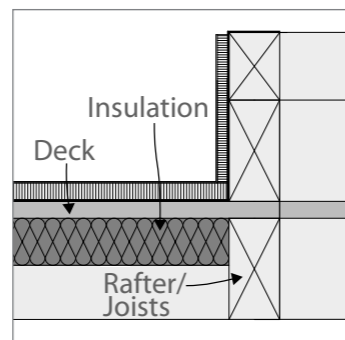

Cold roof

In a cold roof construction, the insulation layer is placed horizontally, directly above the ceiling of the upper story of the building, usually positioned between the joists in the loft space.

ROOF BUILD-UP

The roof can be formed out of different layers and thicknesses. It is important to know the thickness of the materials used to calculate the height of the structural kerb, as detailed on page 8.

ROOF PITCH

The roof window must be installed at a minimum pitch as advised in the table (page 7) to prevent the pooling of water on the roof window. The maximum pitch the roof window can be installed at is 20°



The higher the pitch, the greater the chance of pooling at the head (see head deflector section on how to prevent this).

WATER POOLING

Larger roof windows installed at a shallow pitch risk water pooling on the centre of the glass as it may concave slightly. It is important to install the roof window at no less than the minimum pitch detailed in the table on page 7. If you require further advice, please contact our commercial services team.

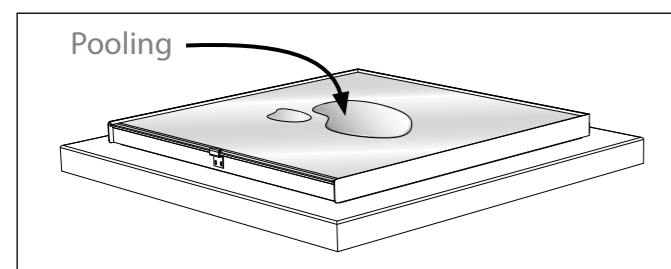

HEAD DEFLECTOR

Water may pool at the head of the roof window, depending on the size and pitch. We suggest the plyboard of the structural kerb is created into a point at the head to encourage water to drain away to each jamb. The angle should be appropriate for the size and the pitch of the roof window being installed.

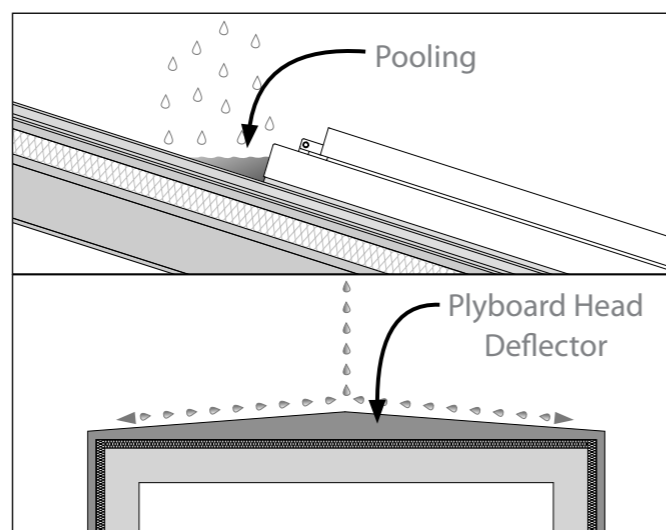

SECTION 4- Structural opening sizes

> Structural kerb dimensions

> Forming the structural kerb

STRUCTURAL KERB DIMENSIONS - WARM ROOF ONLY

The following table provides the dimensions required to create the structural kerb for the Plateau Rooflight.

MODEL REFERENCE NUMBER	MAX. KERB THICKNESS (mm)	INTERNAL STRUCTURAL KERB WIDTH (mm)	INTERNAL STRUCTURAL KERB LENGTH (mm)	MAX. EXTERNAL STRUCTURAL KERB WIDTH (mm)	MAX. EXTERNAL STRUCTURAL KERB LENGTH (mm)	MIN. INSTALLATION PITCH (°)
PL01	75	625	625	775	775	3-5
PL02	75	925	925	1075	1075	3-5
PL03	75	1225	1225	1375	1375	3-5
PL04	75	1525	1525	1675	1675	3-5
PL07	75	925	625	1075	775	3-5
PL08	75	1225	625	1375	775	3-5
PL09	75	1225	925	1375	1075	3-5
PL10	75	1525	925	1675	1075	3-5
PL11	75	1525	1225	1675	1375	3-5
PL12	75	2025	1525	2175	1675	3-5



The required pitch for the roof window will vary depending on the size. Test the roof window prior to fixing to ensure water does not pool on the glass.

FORMING THE STRUCTURAL KERB

To derive the structural kerb dimensions for the Plateau Rooflight, you will need to know the roof window model reference number.

1. Create the structural kerb opening as to the dimensions outlined in the table above for the required model.

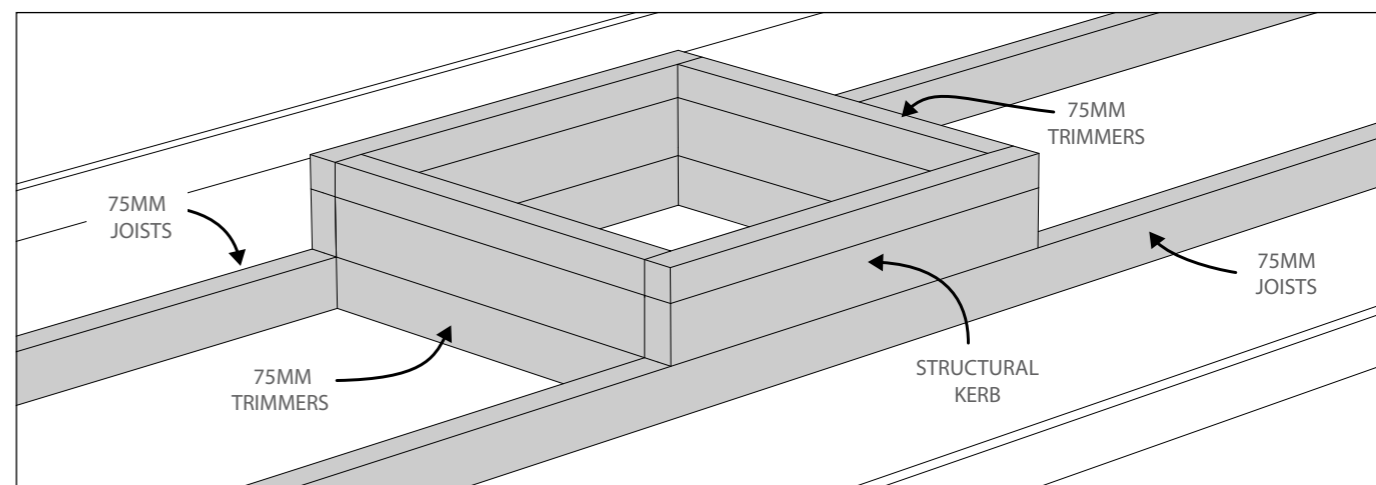
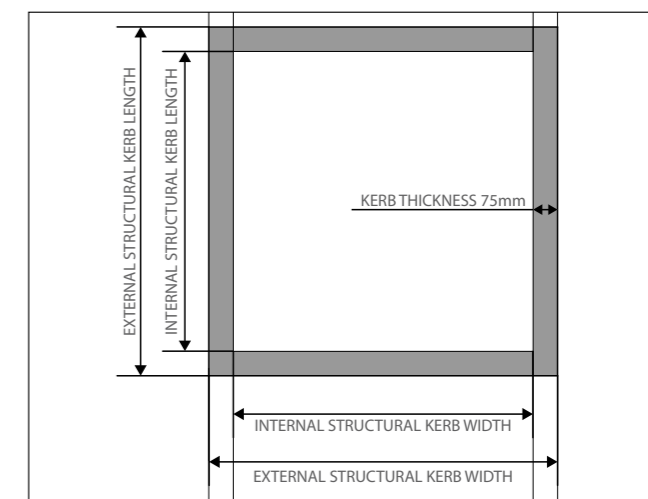

SECTION 4- Structural opening sizes

> Forming the structural kerb

2. Calculate the height of the kerb using the calculation below:

Height from the top of the structural joists (A) = Variable roof build-up + 150 minimum kerb height

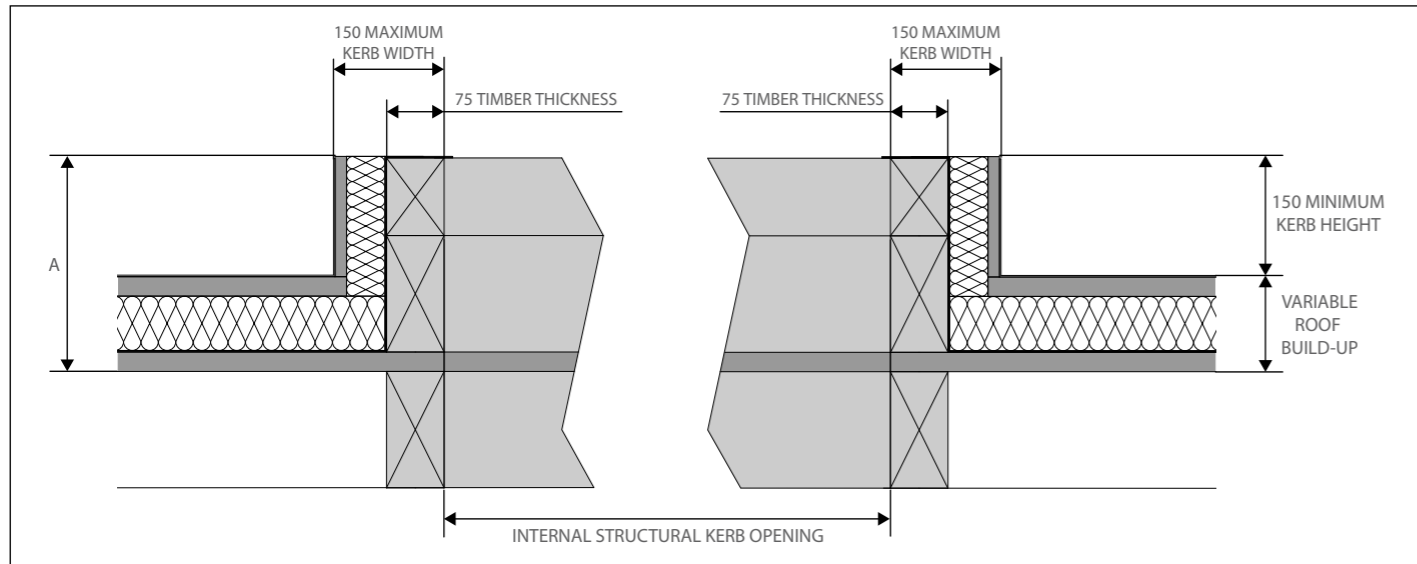

NOTE: Maximum kerb thickness 150mm.

STRUCTURAL KERB OPENING

Prepare the roof structure, ready to install the roof window. The below image is an example of a possible roof build up, the roof should be prepared to this stage.

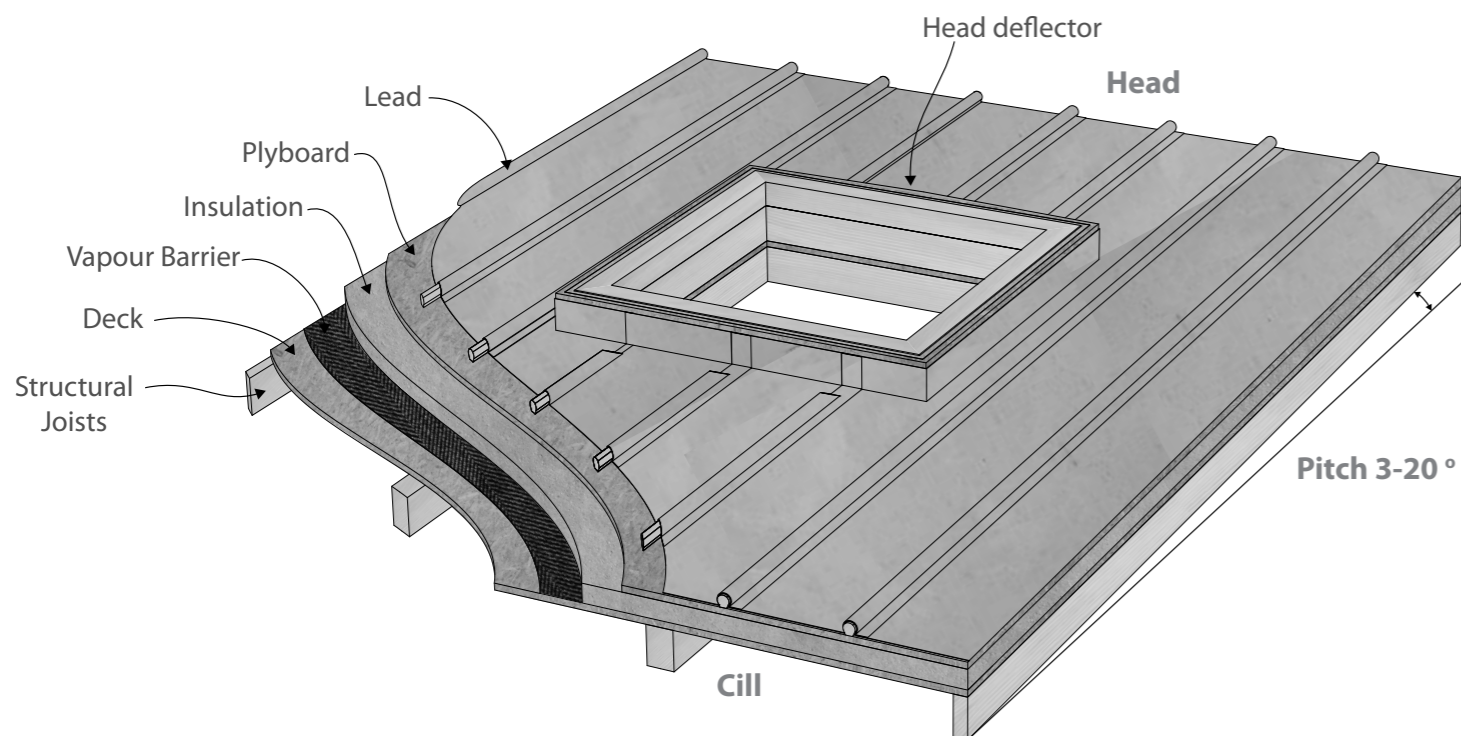

SECTION 5 - Preparing the roof

> Prepare the roof

> Internal timber packer

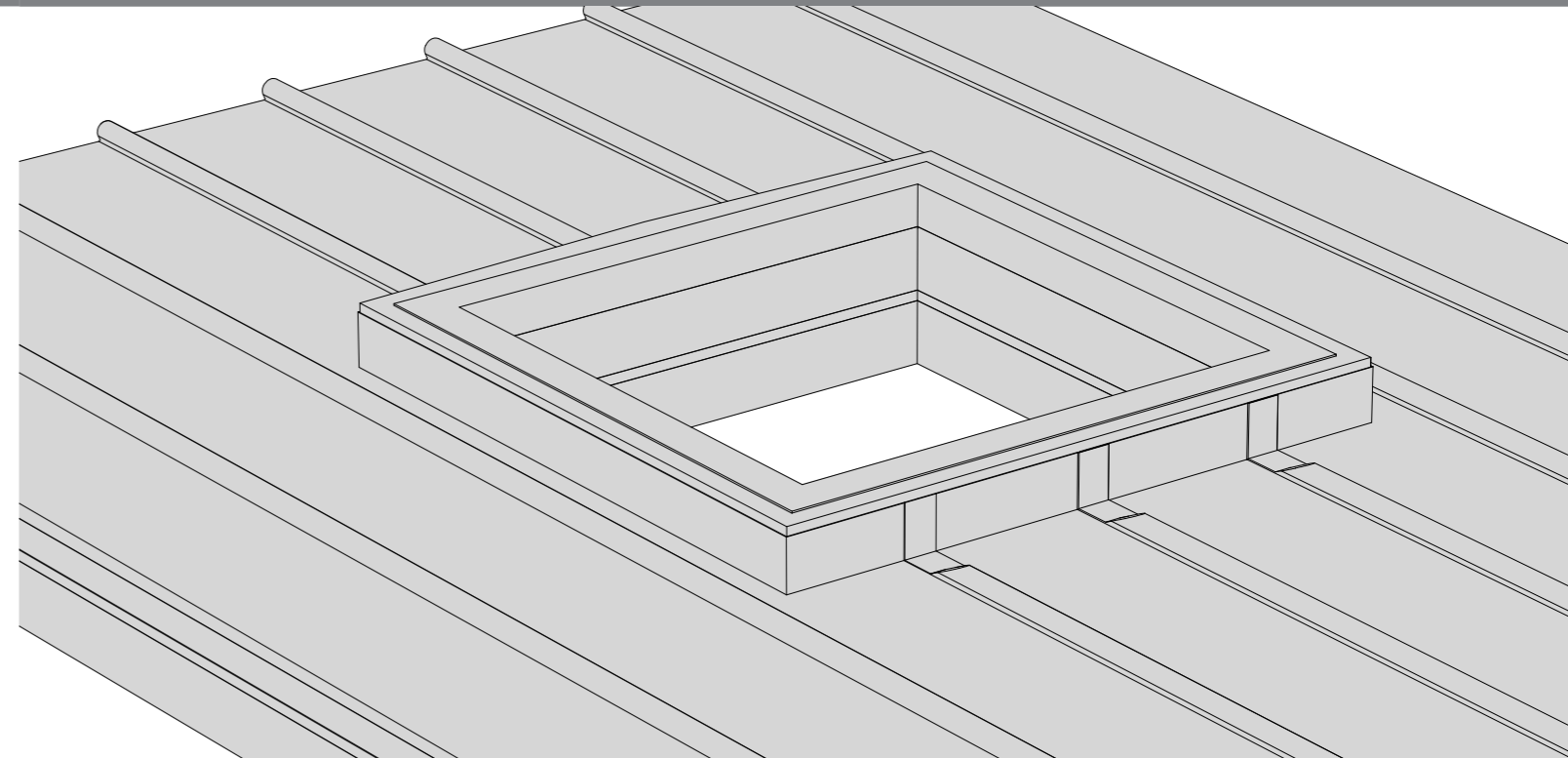

Prepare the roof

Prepare the roof to the guidelines given in this manual.

There are two options to complete this stage, it is entirely up to the installer, however for the purposes of this installation guide we will be using Option A:

- ▶ **Option A** - The timber packer is installed up to the height of where the fixing lug will reach.
- ▶ **Option B** - Notches are made in the timber packer at the location of the fixing lugs and the timber is taken up to the top of the kerb.

Internal timber packer

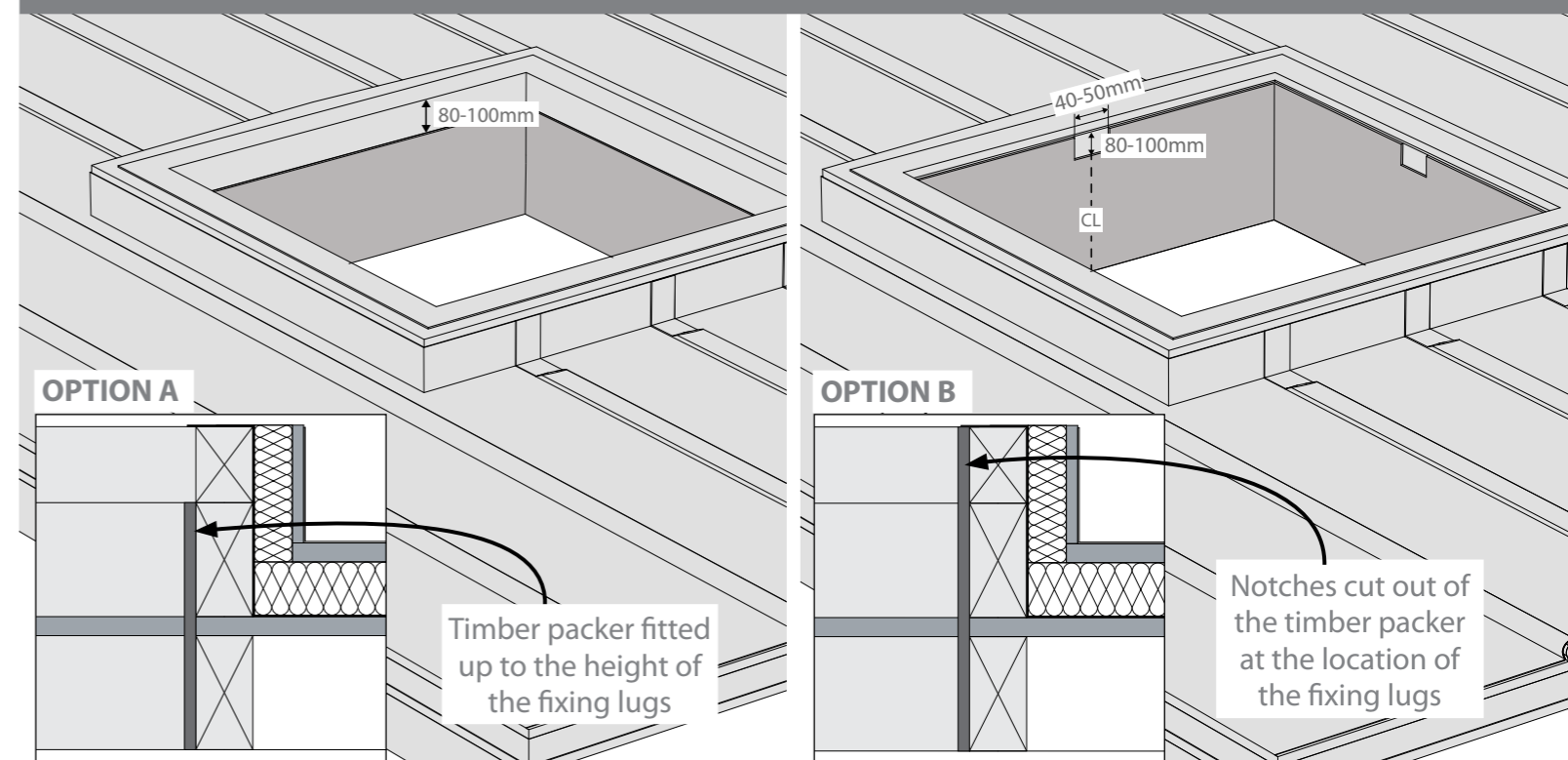

SECTION 5 - Preparing the roof

- > Timber packer
- > Silicone

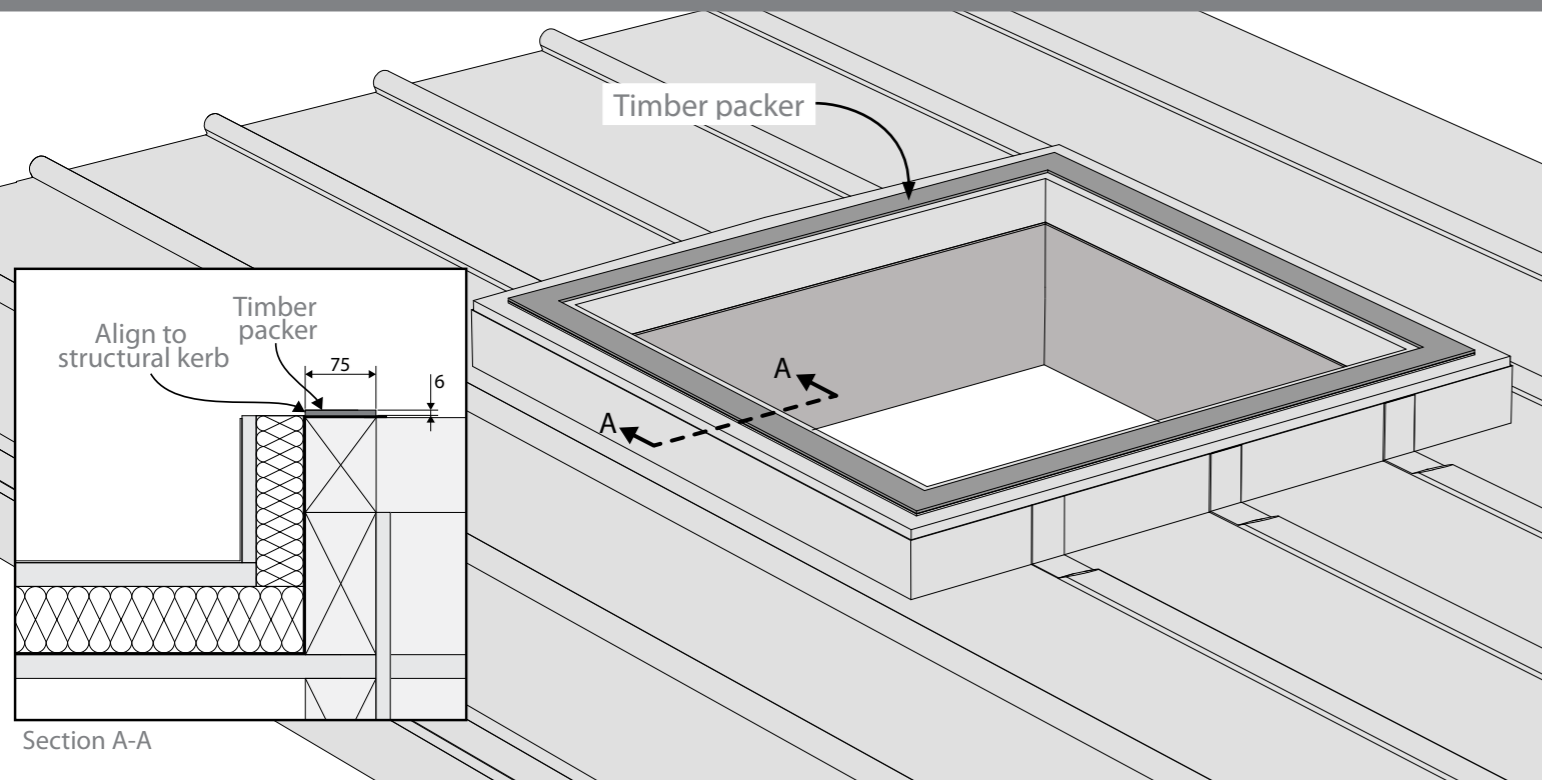

▲ Timber packer

Install a timber packer on top of the kerb for the roof window to sit on.
Thickness - 6mm, Width - max. 75mm

Apply a thick layer of low modulus neutral cure silicone on top of the timber packer.

▼ Silicone

SECTION 6 - Installing the roof window

- > Install the roof window
- > Fix

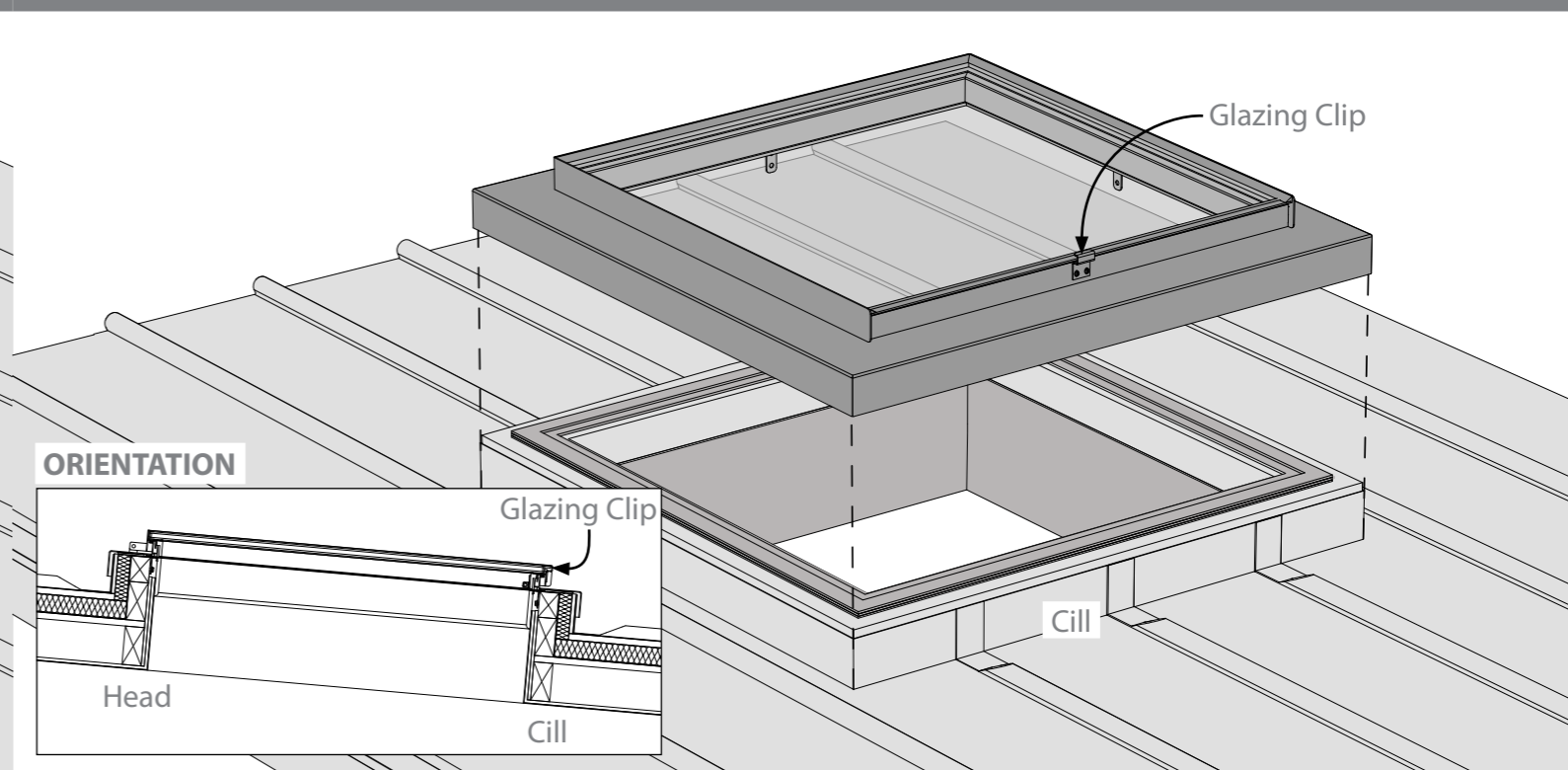

▲ Installing the roof window

Install the roof window. Ensure the Glazing Clip is at the cill of the structural kerb, i.e. where the pitch is sloping down.

Fix the roof window in place at the 4 fixing lugs using coach screws with a large flat washer. **OVER TIGHTENING OF THE COACH SCREWS CAN CAUSE DAMAGE TO THE ROOF WINDOW FRAME.**

▼ Fix

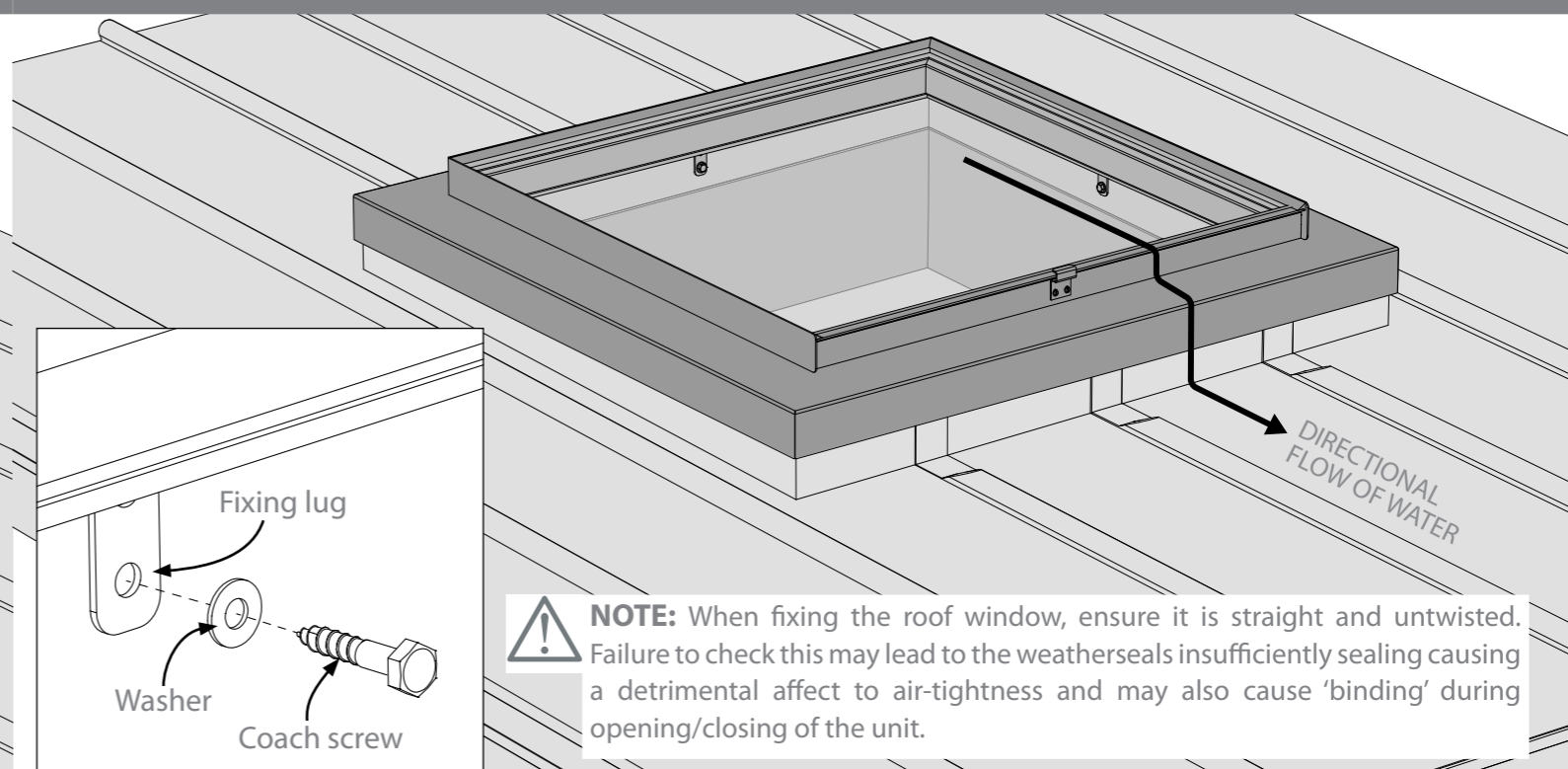
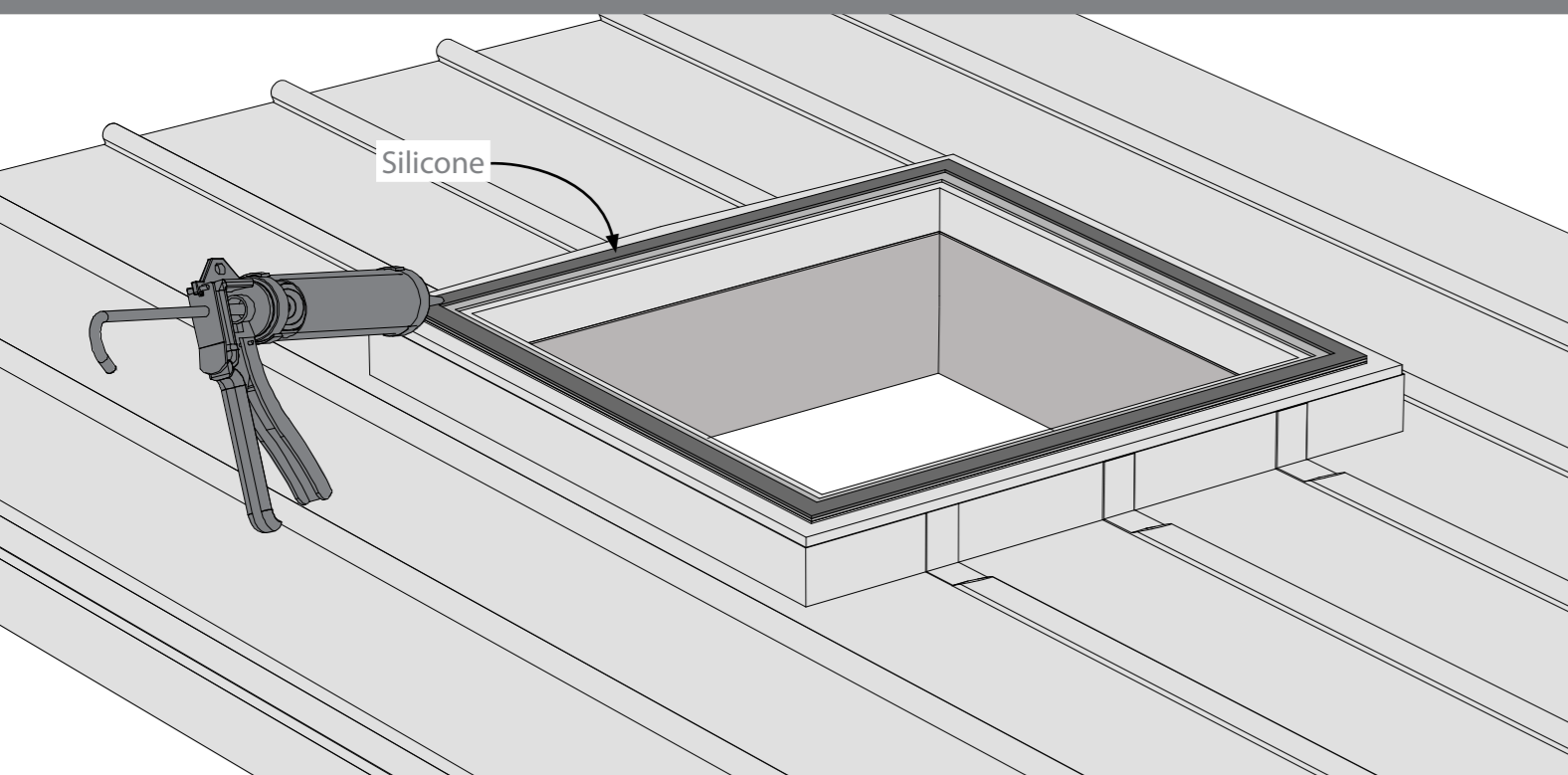

NOTE: When fixing the roof window, ensure it is straight and untwisted. Failure to check this may lead to the weatherseals insufficiently sealing causing a detrimental affect to air-tightness and may also cause 'binding' during opening/closing of the unit.

SECTION 7- Finishing the interior

- > Plasterboard & skim
- > Ironmongery support packer

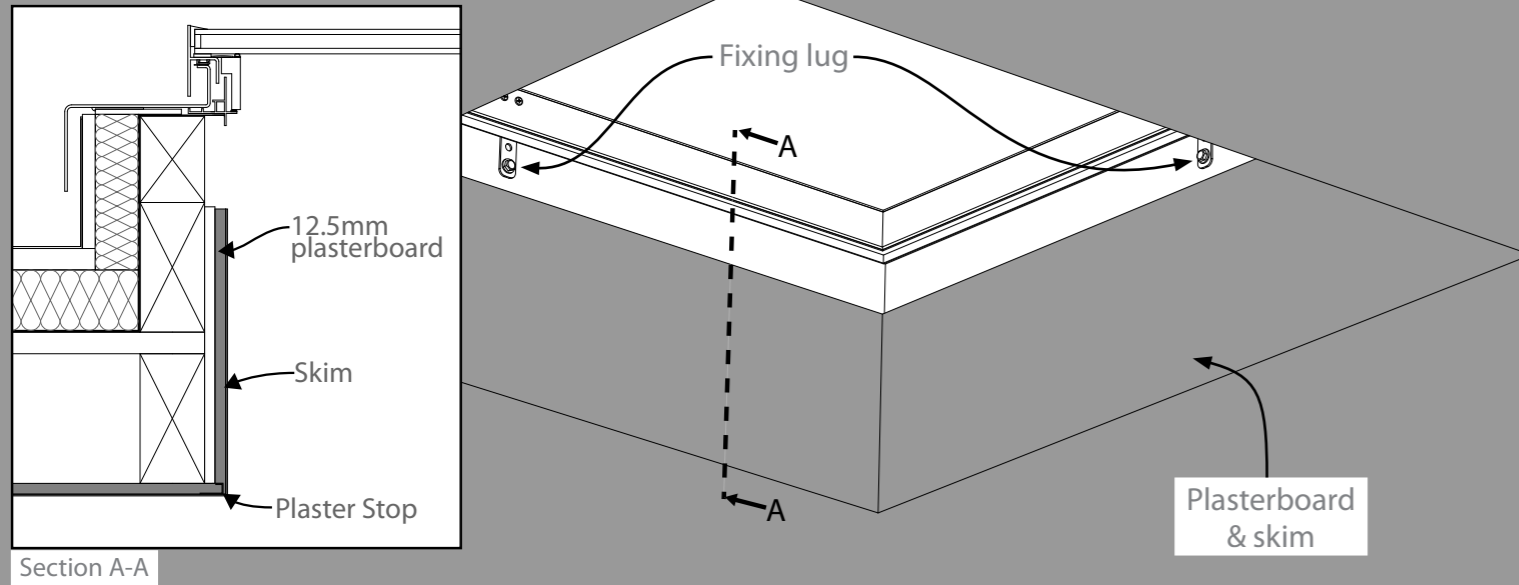

▲ Plasterboard & skim

Install the plasterboard over the ceiling. Ensure there is a 12.5mm overlap with a plaster stop on the corner. Then insert the plasterboard around the head, cill and jambs. Skim the main ceiling plasterboard.

Install timber packers at the cill, directly below the screws in the timber lining, for the ironmongery to fix to (NOTE: PL04 & PL12 have two opening push points therefore will require packers at both locations). This will ensure the Ironmongery support bracket is secure enough to hold the weight of the roof window when open.

▼ Ironmongery support packer

SECTION 7- Finishing the interior

- > Timber reveal
- > Paint linings

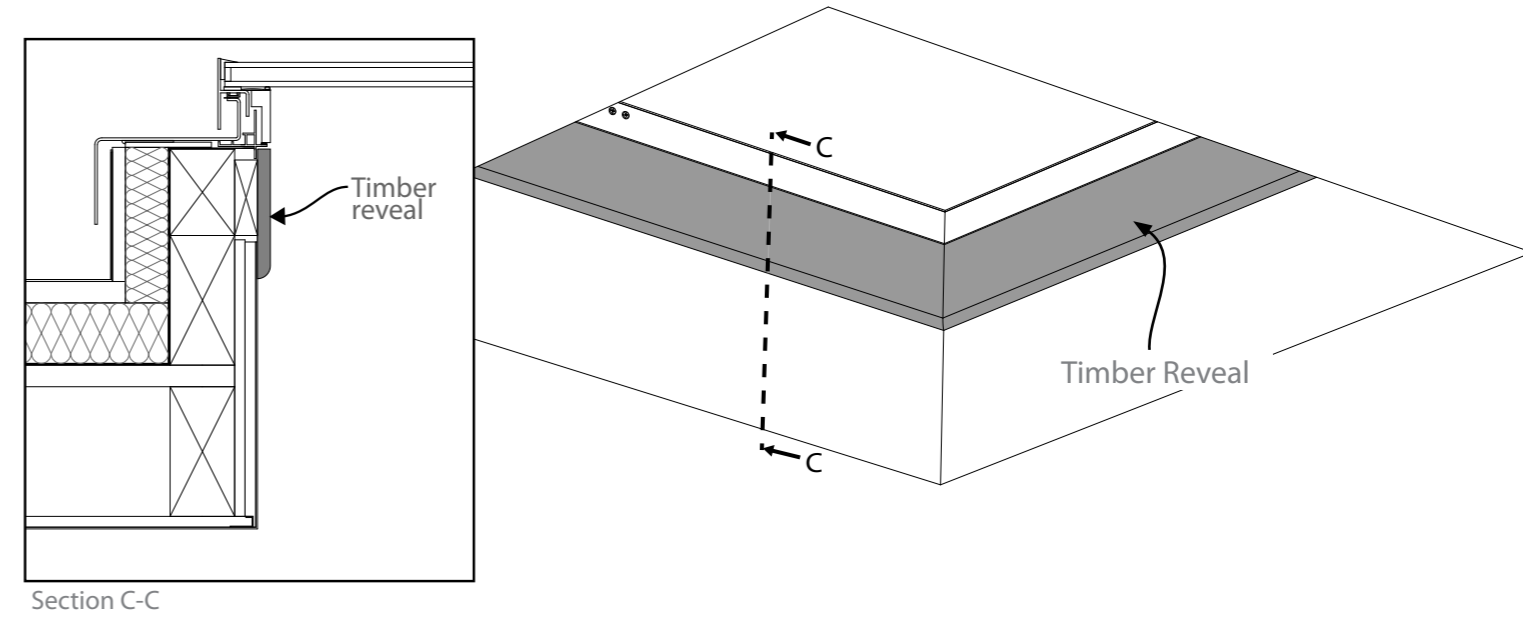

▲ Timber reveal

To complete the installation and provide a frameless internal appearance, fit a timber reveal around the head, cill and jambs, over the plasterboard. Ensure there is no interference with the thermoliner.

For roof windows without a factory painted timber lining- this step must be completed to ensure longevity of this component. Paint the treated timber lining with a timber finishing paint. Ensure all four sides are painted.

▼ Paint linings

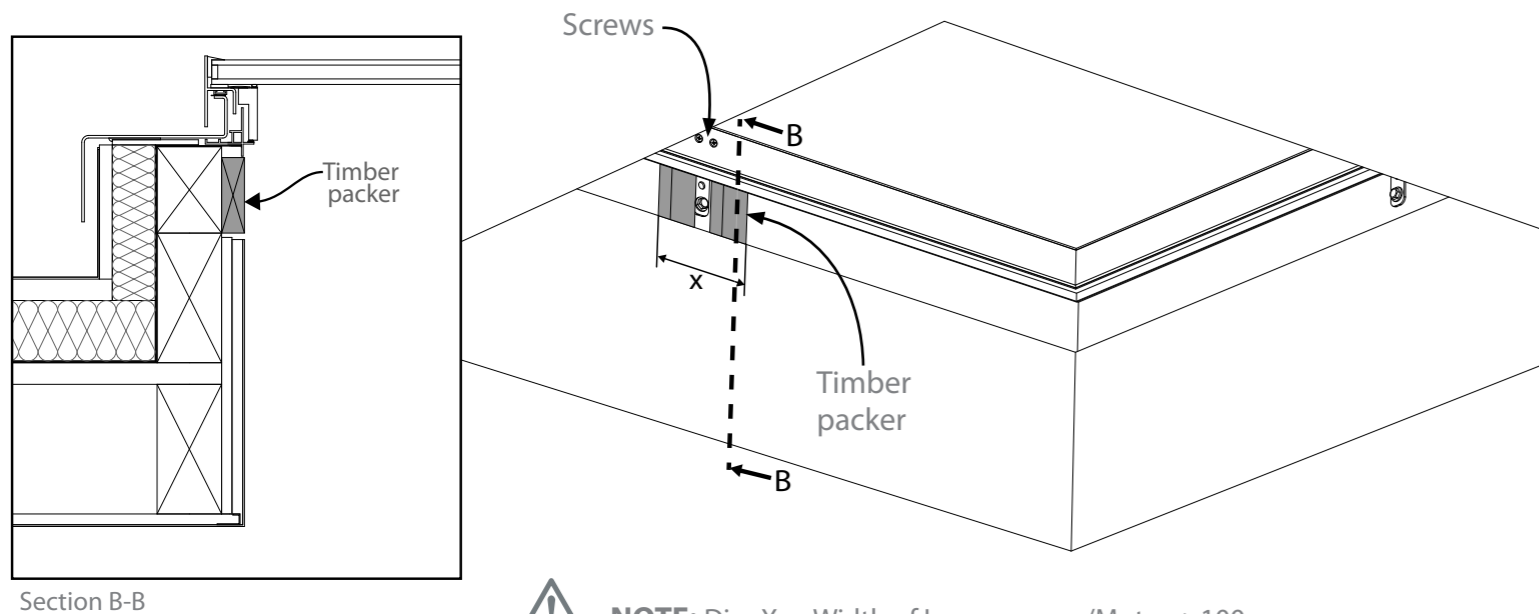

NOTE: Your guarantee may be affected if you fail to undertake this installation step.

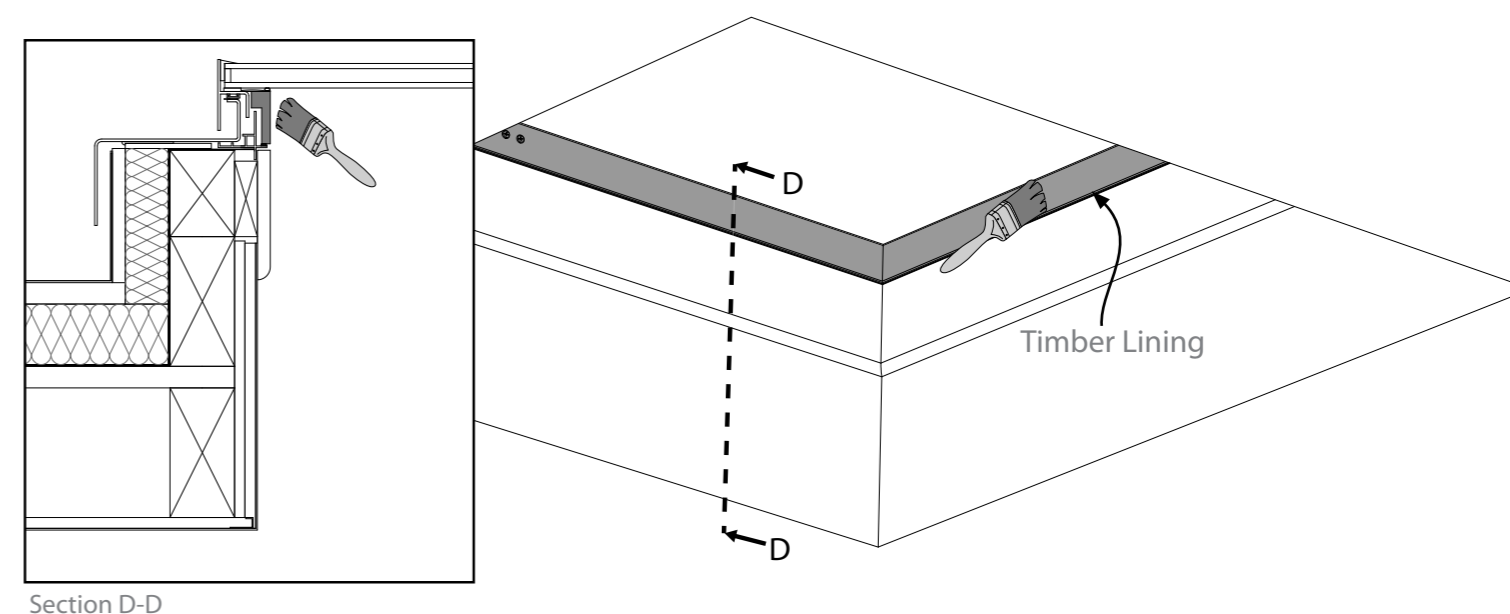

SECTION 8 - Installing the ironmongery

- > Typical options
- > Ironmongery spindles for large roof windows
- > Additional tools to install the ironmongery

The following section will provide instructions on how to install the chosen Ironmongery for roof windows that open.

> Typical Options

HAND WINDER

Telescopic with hand winder for roof windows within reach.

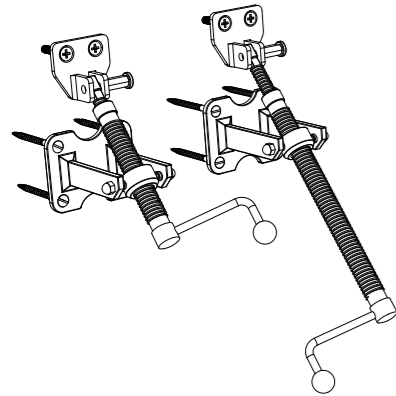

CHROME 150mm (Option J)
300mm (Option B)
BRASS 150mm (Option A)
300mm (Option E)

HAND WHEEL

Telescopic with hand wheel for roof windows within reach.

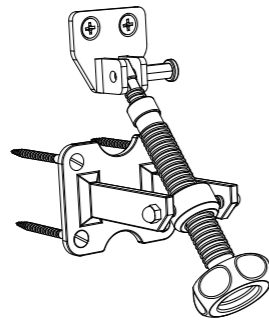

CHROME 150mm (Option W)
BRASS 150mm (Option Y)

EYELET

Telescopic with pole winder for roof windows out of reach (Additional pole is required to operate)

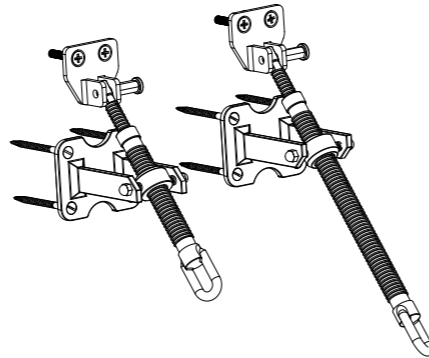

CHROME 150mm (Option L)
300mm (Option C)
BRASS 150mm (Option K)
300mm (Option D)

> Ironmongery Spindles for large roof windows

For PL04 & PL12 two of these options can be linked using a connecting rod to create a dual winder.

OPTION M & T

Anodised aluminium pole winder for roof windows out of reach (Additional pole is required to operate).

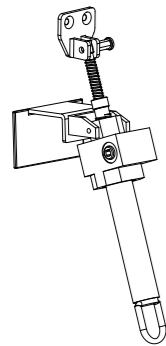

OPTION M 300mm
OPTION T 500mm

OPTION P

Anodised aluminium with cord operated gear for roof windows out of reach.

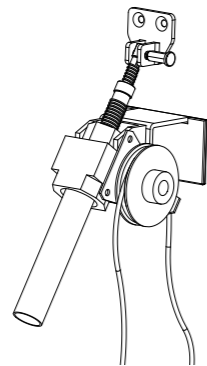

OPTION P 300mm



NOTE: Poles for opening out of reach roof windows can be purchased from the Rooflight Company. Please contact our commercial services team.

> Additional tools to install the Ironmongery

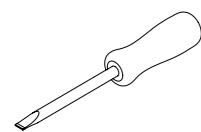

Screw Driver

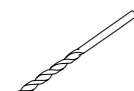

2mm Wood Drill Bit

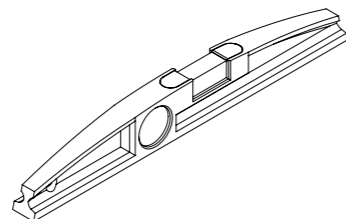

Spirit Level

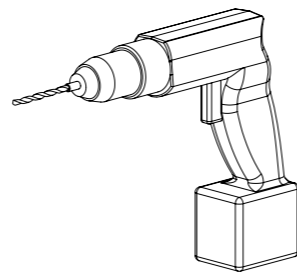

Drill

SECTION 8 - Installing the ironmongery

>Parts list

> Remove roof window screws

> Parts list

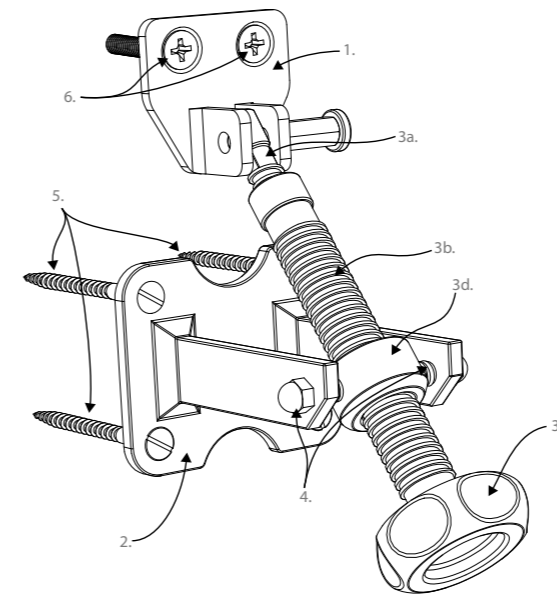

Part No.	Description	Quantity
1	Spring Clip (Plunger & Bracket)	1
2	Ironmongery Support Bracket	1
3	Spindle	1
	3a Inner Spindle	1
	3b Outer Spindle	1
	3c Handle	1
	3d Gimble	1
4	Spindle Retaining Screw	2
5	No. 8 Wood Screws (Ironmongery Support Bracket).....	4
6	No. 9 Machine Screws (Spring Clip).....	2

Note: If you are installing ironmongery with a chrome finish these screws are supplied with the roof window not the ironmongery.

Using a screw driver, remove the two screws and plastic caps from the timber lining of the roof window. Retain the two screws. For ironmongery with a chrome finish, retain screws (Part 9) from the installed roof window to attach to the ironmongery support bracket.

▼ Remove roof window screws

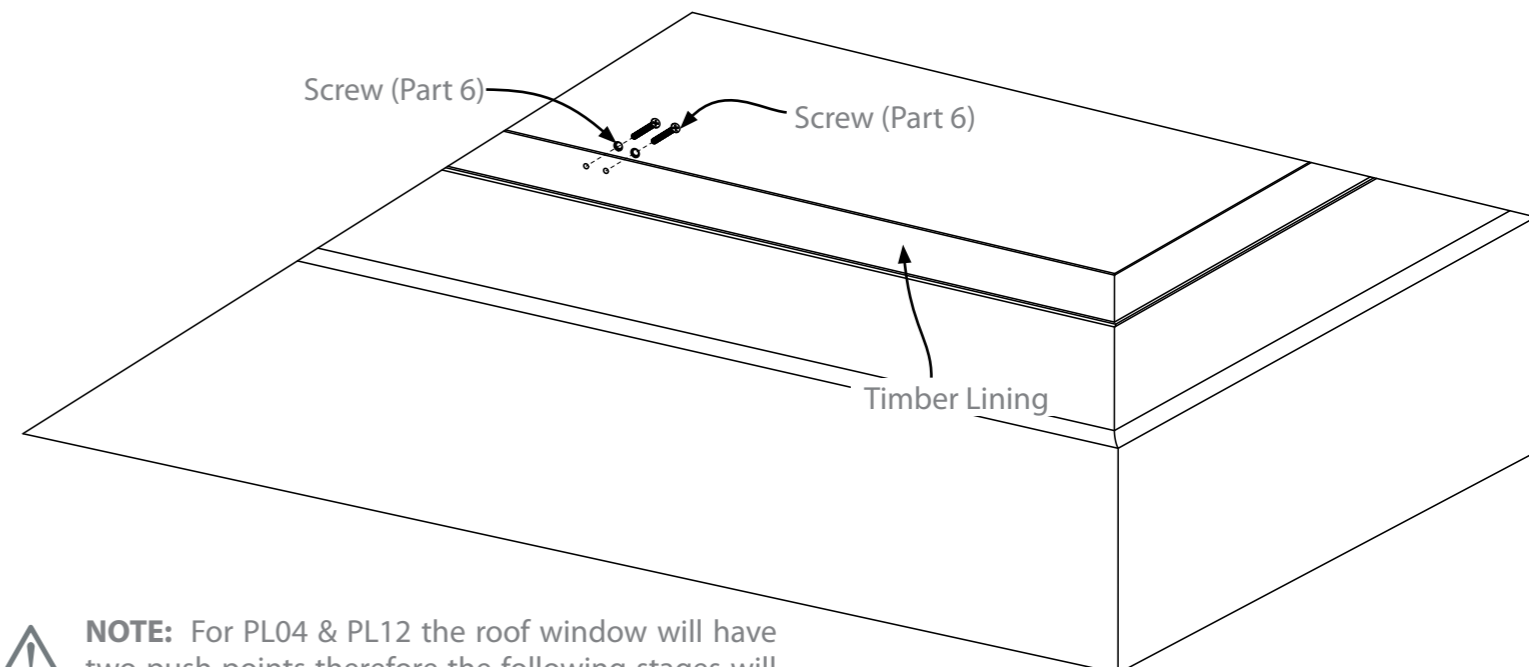

NOTE: For PL04 & PL12 the roof window will have two push points therefore the following stages will need to be repeated. See page 19 for final installation.

SECTION 8 - Installing the ironmongery

- > Spring clip
- > Attach ironmongery

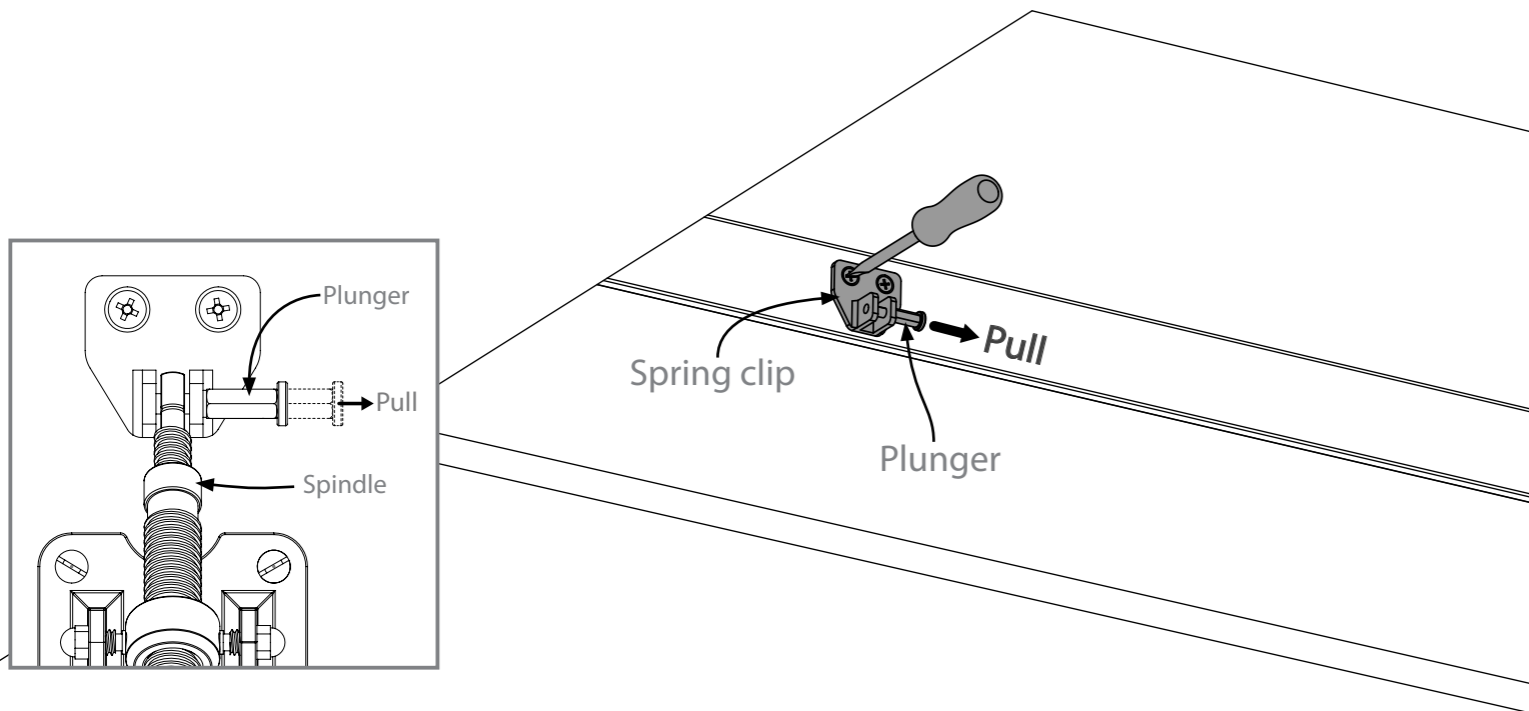

▲ Spring clip

Remove the spring clip (Part 1) from the ironmongery by pulling the plunger out. Fit the spring clip into the timber lining holes with the two screws (Part 6) that had previously been removed.

Re-attach the ironmongery (Part 3) to the spring clip (Part 1). Ensure that majority of the spindle is wound in.

▼ Attach ironmongery

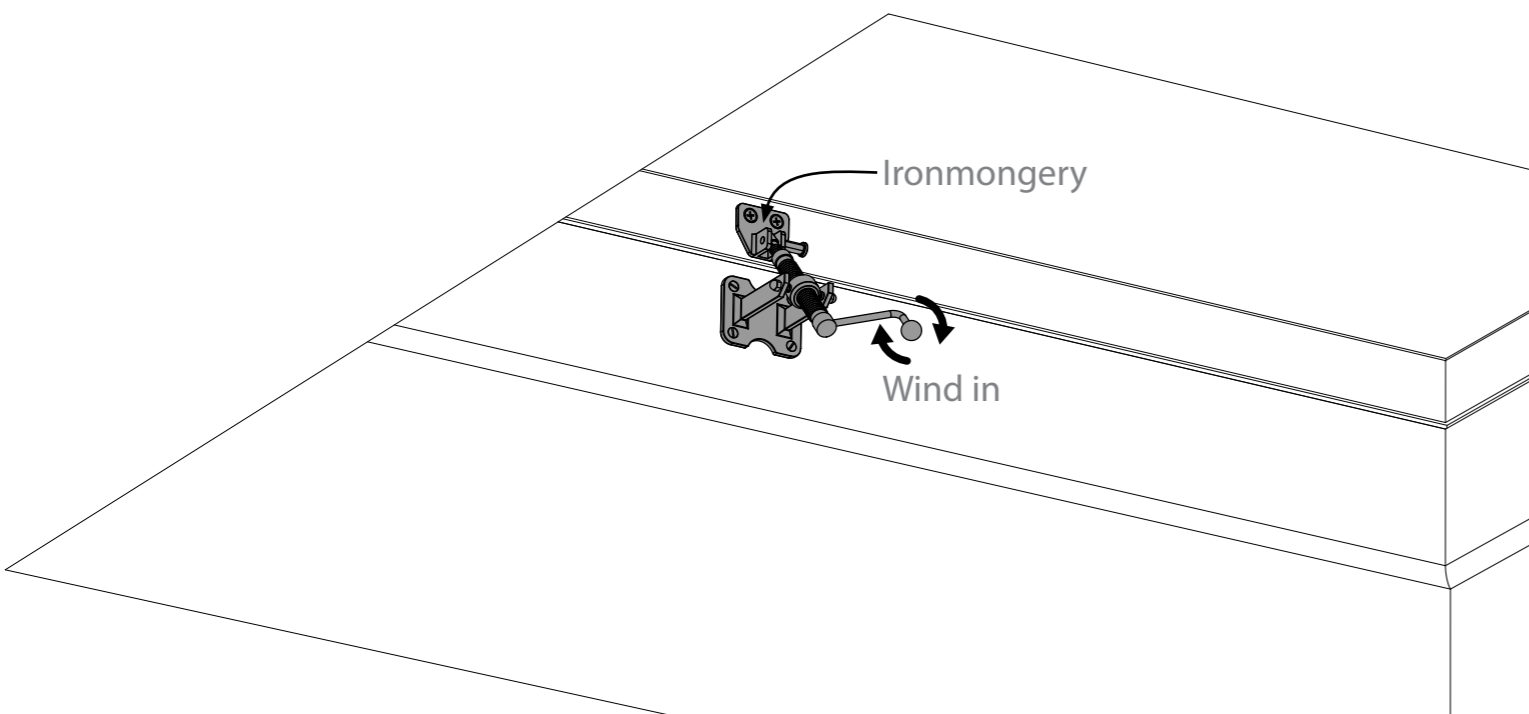

SECTION 8 - Installing the ironmongery

- > Positioning the ironmongery
- > Pilot holes

NOTE: For PL04 & PL12 ensure holes are level for both push points.

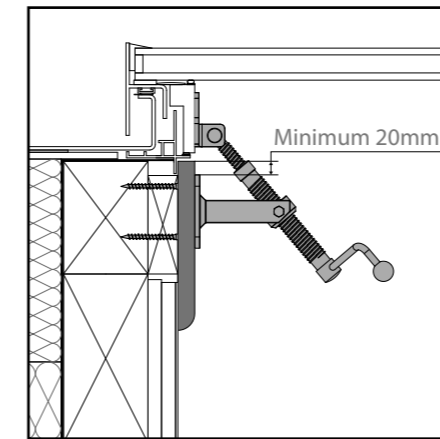

Section E-E

Minimum 20mm

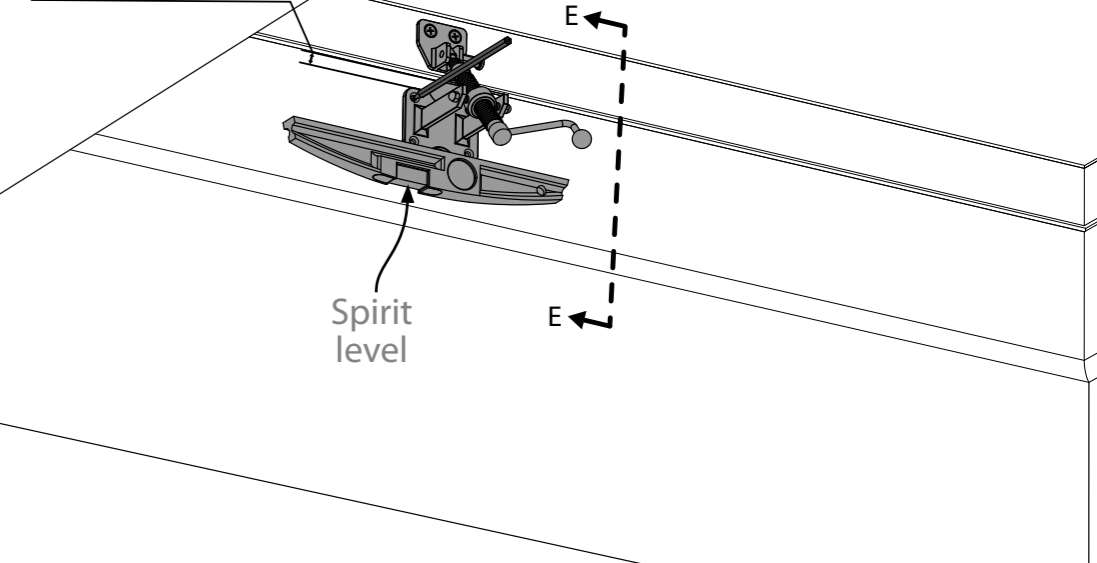

▲ Position the ironmongery

Position the ironmongery supporting bracket (Part 2). As shown, use a spirit level to ensure it is level. The aim is to position the ironmongery so it provides as much travel as possible. Once you are happy with the position, mark the four holes to be drilled.

Remove the spindle (Part 3) from the spring clip (Part 2) and drill 4 pilot holes using a 2mm drill bit.

▼ Pilot holes

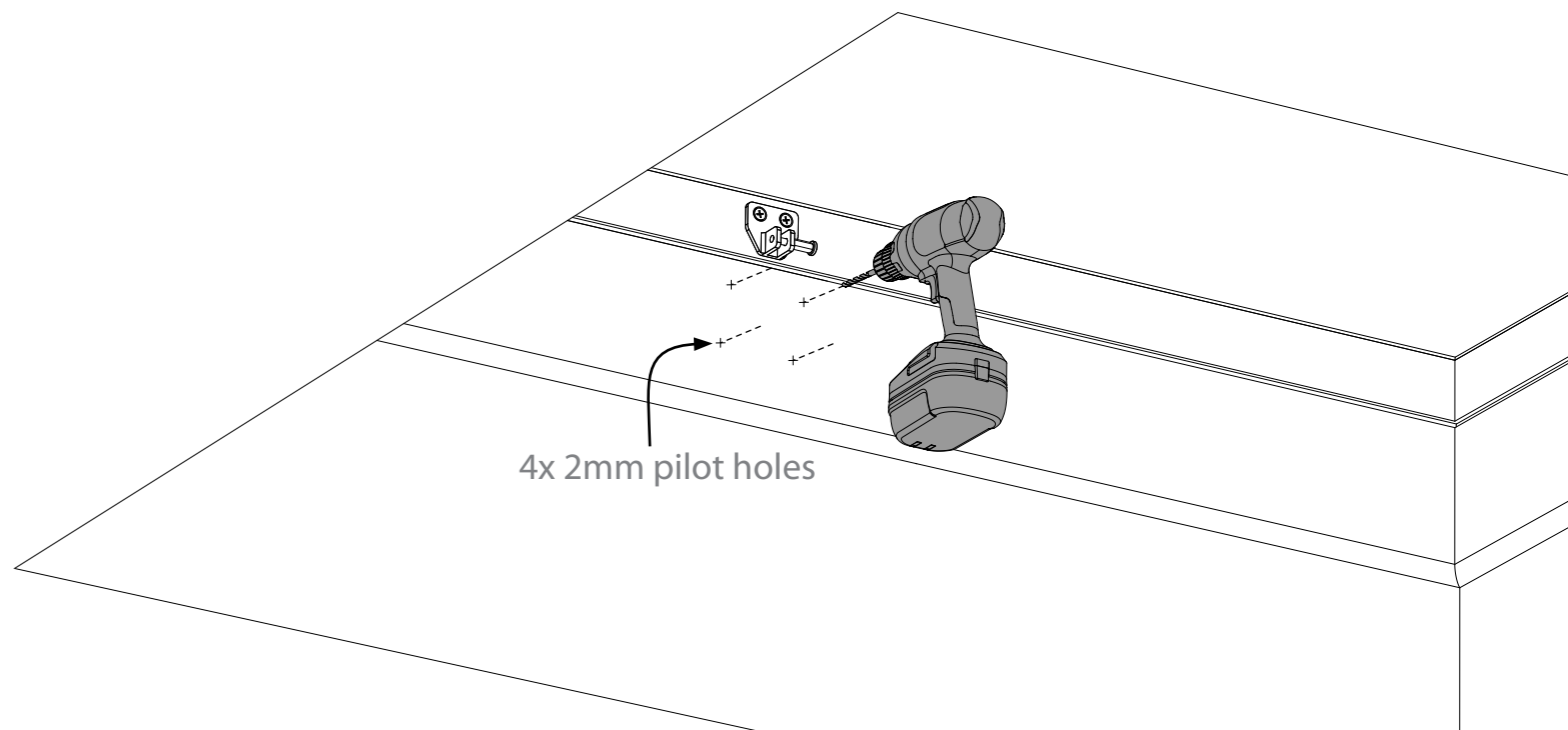

4x 2mm pilot holes

SECTION 8 - Installing the ironmongery

- > Fix the ironmongery support bracket
- > Re-attach the spindle

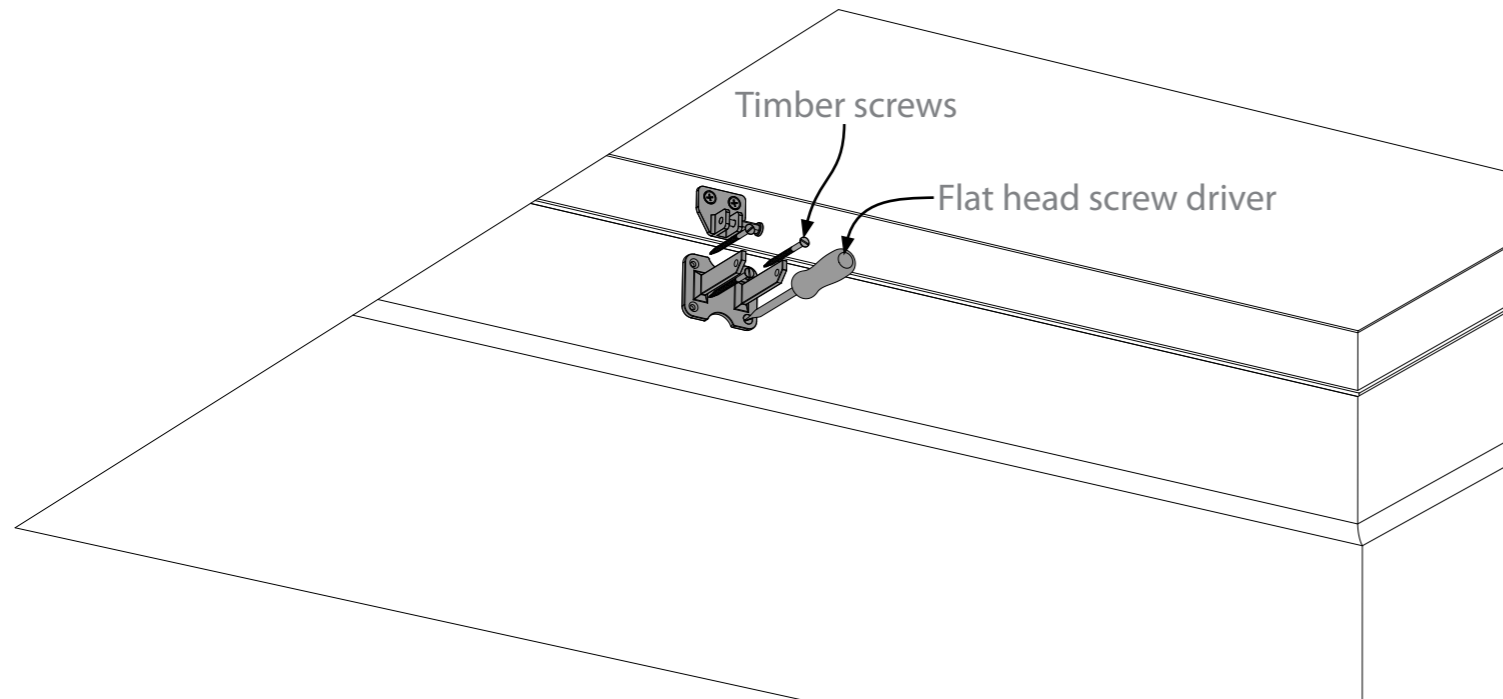

▲ Fix the ironmongery support bracket

Remove the spindle sub-assembly (Part 3) from the ironmongery support bracket (Part 2) by unscrewing the two spindle retaining screws (Part 4). Fix the bracket in place with the four wood screws (Part 5).

Apply a water-displacing spray (such as WD 40) to the spindle (Part 3a & 3b) to ensure it is lubricated and runs freely. Re-attach the spindle (Part 3) to the ironmongery support bracket (Part 2) using the spindle retaining screws (Part 4) and spring clip (Part 1) by pulling back the plunger.

▼ Re-attach the spindle

SECTION 8 - Installing the ironmongery

- > Test
- > Dual winders & connecting rods

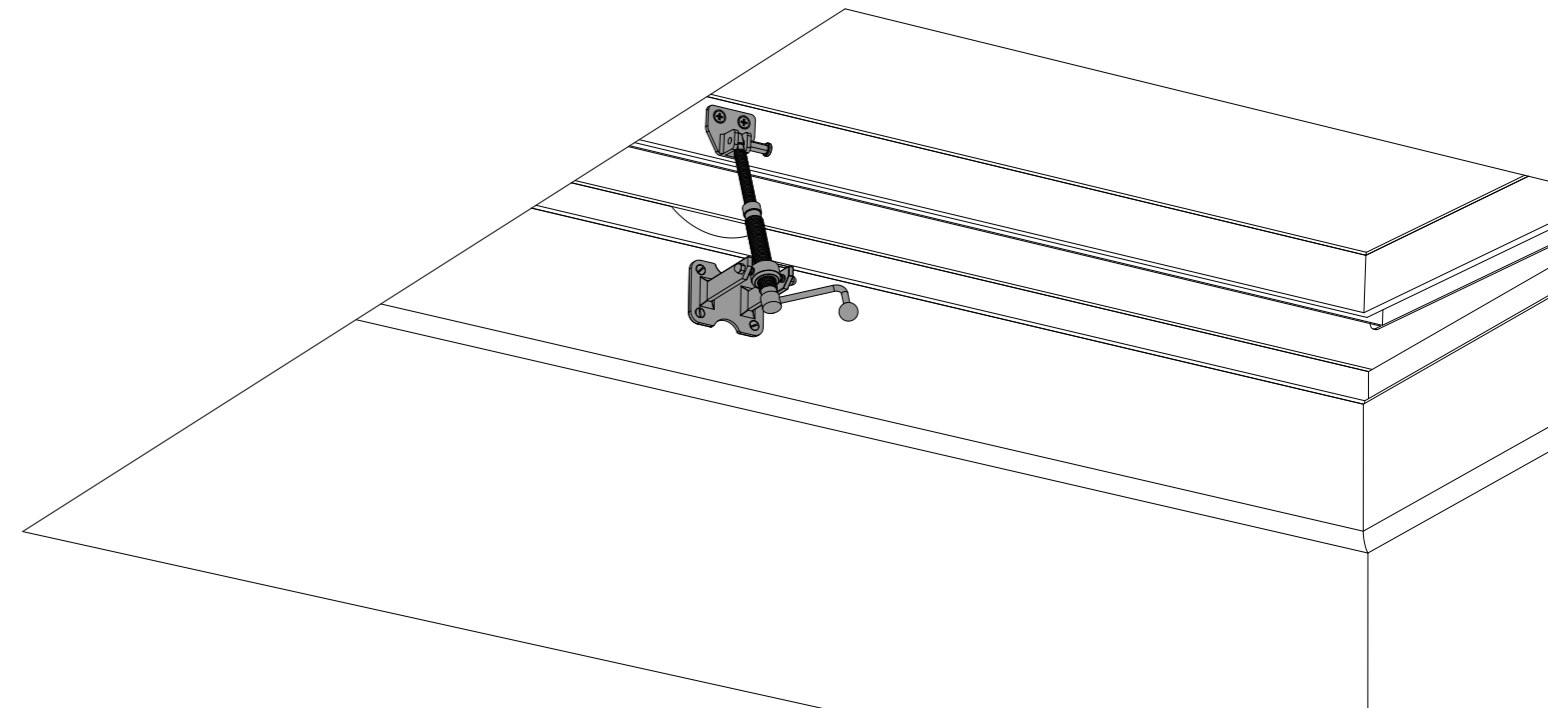

▲ Test

Test the spindle to ensure it runs freely by turning the handle. Ensure the roof window opens level and the fixings are all secure. This then completes the installation of the ironmongery.

For models PL04 & PL12 with two push points, the ironmongery should be installed to the instructions outlined in this manual at both fixing locations. Join the ironmongery with the connecting rod so the roof window opens parallel. Options M, T or P are available for large roof windows.

▼ Dual winders & connecting rods

NOTE: If the spindle is attached to the ironmongery support bracket when lubricating the spindle, ensure the paint work is protected to avoid damaging the finish.

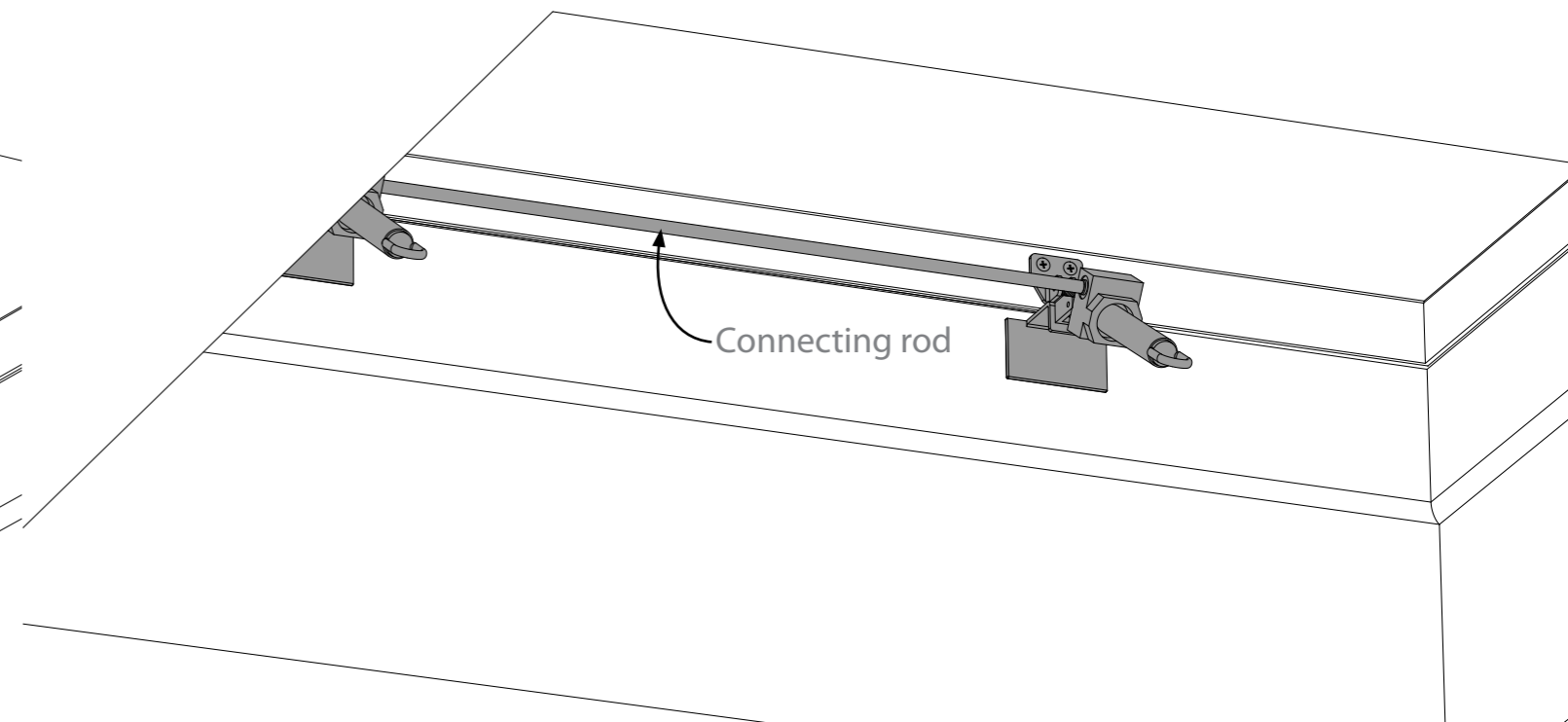
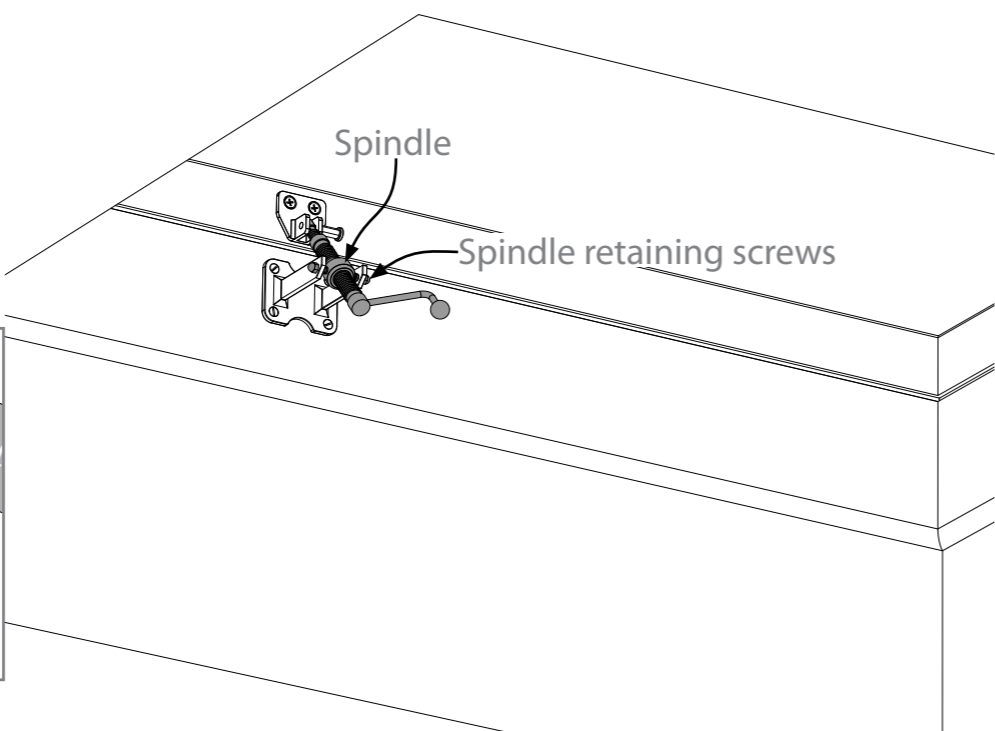
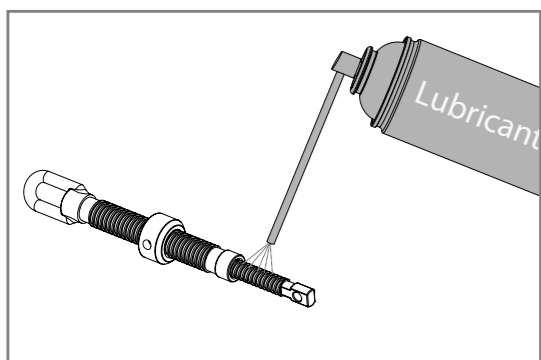

CARE & MAINTENANCE

> Servicing the roof window



To achieve the maximum service life from the Plateau Rooflight it is important that scheduled care and maintenance is undertaken. Please note that the guarantee may become void if the procedures outlined in the separate maintenance manual are not adhered to. Refer to separate **TECHNICAL SPECIFICATION AND MAINTENANCE DETAILS FOR METAL FRAMED ROOF WINDOWS**

> Servicing the ironmongery

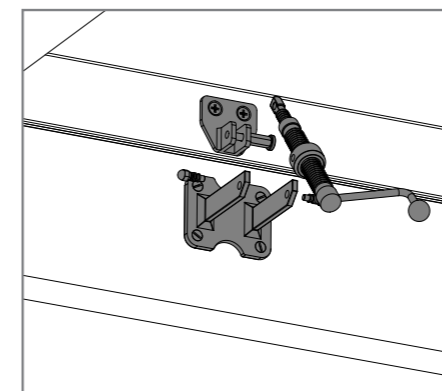

Detach the inner spindle (Part 3a) from the spring clip (Part 1) by pulling back the plunger. Remove the spindle from the ironmongery support bracket (Part 2) by unscrewing the retaining screws (Part 4).

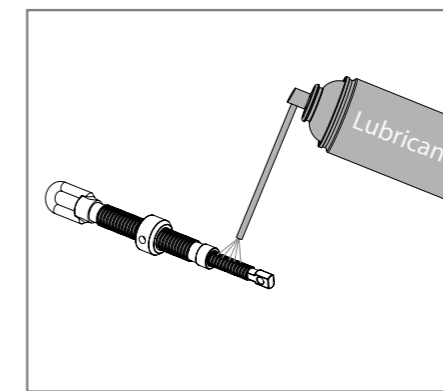

Fully unwind the spindle (Part 3). Apply a water-displacing spray (such as WD 40) to the spindle. Fully wind the spindle out to ensure all of the thread is lubricated.

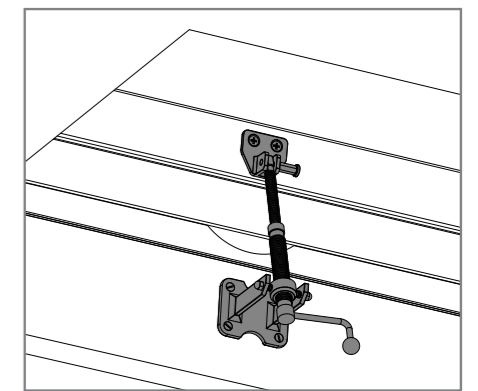

Re-attach the spindle (Part 3) to the ironmongery supporting bracket (Part 2) and spring clip (Part 1). Test the ironmongery is operating.

CONFORMITY



Refer to separate **DECLARATION OF PERFORMANCE DOCUMENTATION**



EN 14351-1 : 2006+A1: 2010

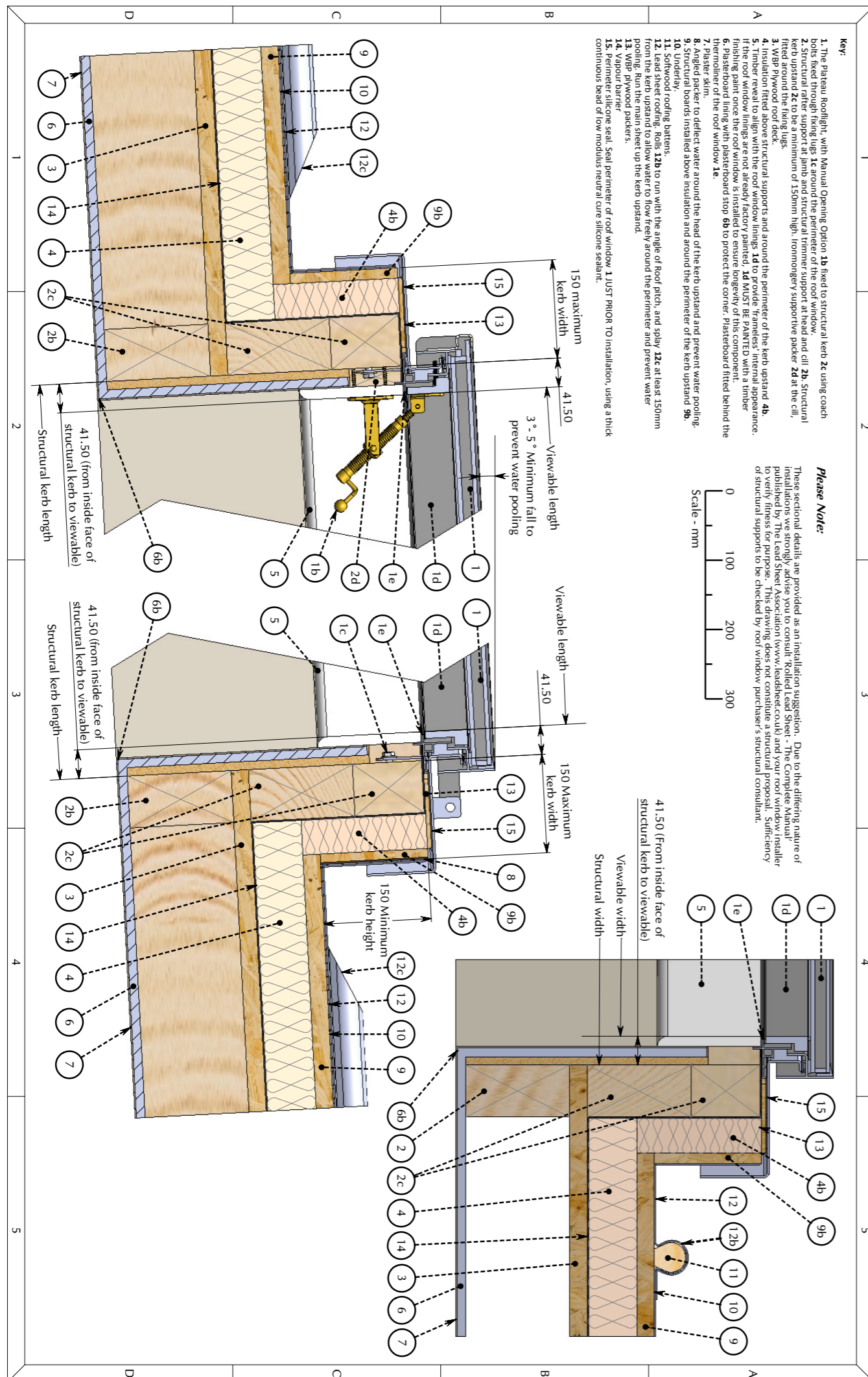

TITLE: The Plateau Rooflight

> A roof window range suitable for pitched roofs between 3° and 17.5°

Warm Roof Insulated Kerb Lead Sheet Installation Detail

DWG NO.: PL_WRLD_B

SHEET NO.: 1 OF 1

SCALE: 1:5 @ A3

DATE: 10/04/2013

REVISION: B

Revised installation

DB: EH
CB:PD

the Rooflight Company
The Professionals' Choice

www.therooflightcompany.co.uk

All information contained within this drawing is copyright © and design right of the Rooflight Company. The intellectual property rights of the products detailed within this drawing and embedded 3D models are owned by the Rooflight Company.

t: 01 993 833 108
e: info@therooflightcompany.co.uk

ADVISORY



Standard roof window: All the information provided in this document refers to a standard specification Plateau Rooflight.



This roof window is NOT INTENDED TO BE WALKED UPON or bear the load of any persons upon the glazing or frame. Roof designers should ensure safety systems are provided eg. suitable balustrading or fall-restraint systems are in place if this roof window is to be used on roof's that are accessible /accessible for maintenance.



Install in accordance with national building regulations/codes. This manual is an installation suggestion and installers should verify 'fitness for purpose' in accordance with all applicable regulations/ standards at time of installation.



Structural support: Structural supports for the Plateau Rooflight are to be designed and supervised during construction by the roof window installer or project Structural Engineer. Nothing in this manual constitutes a structural proposal. Sizing/positioning of structural supports should be determined by the projects suitably qualified structural engineer.

ROOF WINDOW WEIGHTS

When handling and installing the Plateau Rooflight its weight should be considered and adequate means employed to move the roof window into position to reduce the risk of accidents.

MODEL REFERENCE NUMBER	CASEMENT WEIGHT (kg)	BASEPLATE WEIGHT (kg)	OVERALL ROOF WINDOW WEIGHT (kg)
PL01	27	28	55
PL02	37	38	75
PL03	61	49	110
PL04	92	59	151
PL07	36	33	69
PL08	46	38	84
PL09	61	43	104
PL10	73	49	122
PL11	92	53	145
PL12	142	67	209

PRODUCT IDENTIFICATION DETAILS

Place identification sticker here or fill in the following details.

Serial number: _____

Model Number: _____

Date of manufacture: __/__/____

FURTHER INFORMATION

All of the images in this guide are diagrammatic (with some components omitted for clarity). They should be used as a reference and may not be a true representation of the installation.

Installation instructions are regularly reviewed and we reserve the right to update or amend these details without alteration to this guide.



the Rooflight Company

The Professionals' Choice



Designed in the U.K

Assembled in the U.K.

Wychwood Business Centre

Milton Road

Shipton-under-Wychwood

OX7 6XU

Tel: 01993 833108

Fax: 01993 831066



Email: info@therooflightcompany.co.uk

www.therooflightcompany.co.uk



EN 14351-1 2006+A1 : 2010



BS EN 1279-2
BS EN 1279-3



Assessed to ISO 9001
LPCB ref. no. 929



RECYCLE



INVESTOR IN PEOPLE

In the interest of continuous product development, it may be necessary to amend specification without alteration to technical literature.
All drawings and designs are the Copyright and Design right of The Metal Window Company Ltd.