

Loft Hatch



At last a loft hatch designed for a high end finish! Almost invisible when fitted. Personally my heart sinks when I walk into an expensive house or multi-million pound flat and see a nasty cheap plastic loft hatch that totally spoils the effect the architect was trying to achieve. Our loft hatch complies with all the building regulations for insulation, air tightness, L1 & L2, NHBC size requirements, robust documentation and is also fire rated. But don't just use it because its fire rated, use it because its beautiful and your client will love it.

For the best result we recommend specifying the beaded frame variety where the frame edge is tape and jointed or skimmed into the ceiling membrane. Ensure the door face is overpainted to match the ceiling. If your ceiling is already finished there is a picture frame option with 'soft' corners to cover the cut edge of the aperture. This panel is finished in a polyester powder coated white textured finish, which can also be overpainted. The door tray is hinged in its short length by two pivot hinges and locked by a concealed key operated square drive lock. For a traditional look we can also raise a panel in the centre of the door tray and return the frame to stand off the surface by 7mm.

To open all our loft hatches from the floor specify the 'Slik' keyhole system and an extra long key. Open the hatch and pull down ladders without using steps. Security locks are available for communal areas.

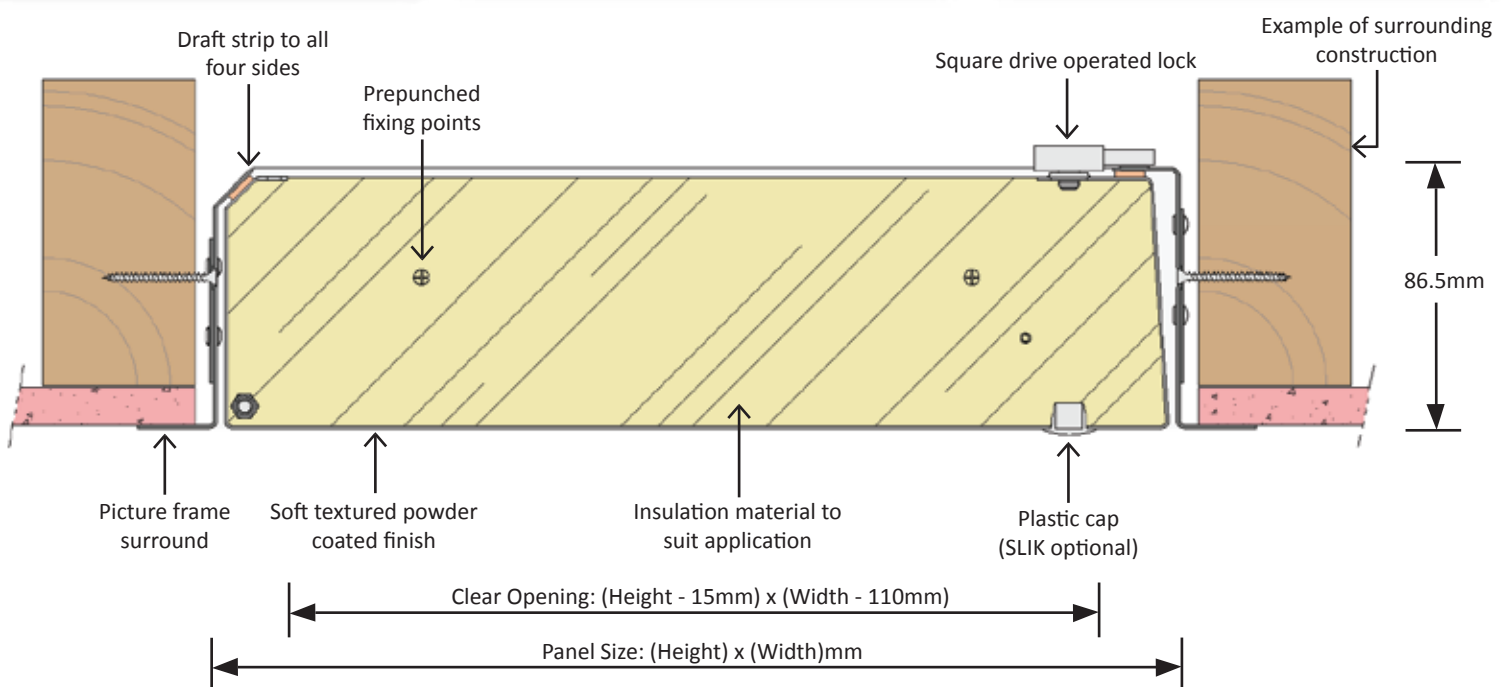

Our design office will be pleased to tailor a drawing to your exact requirements in your preferred format from 3D rendered images to line drawn DXF, DWG or other CAD formats.

For Ceilings

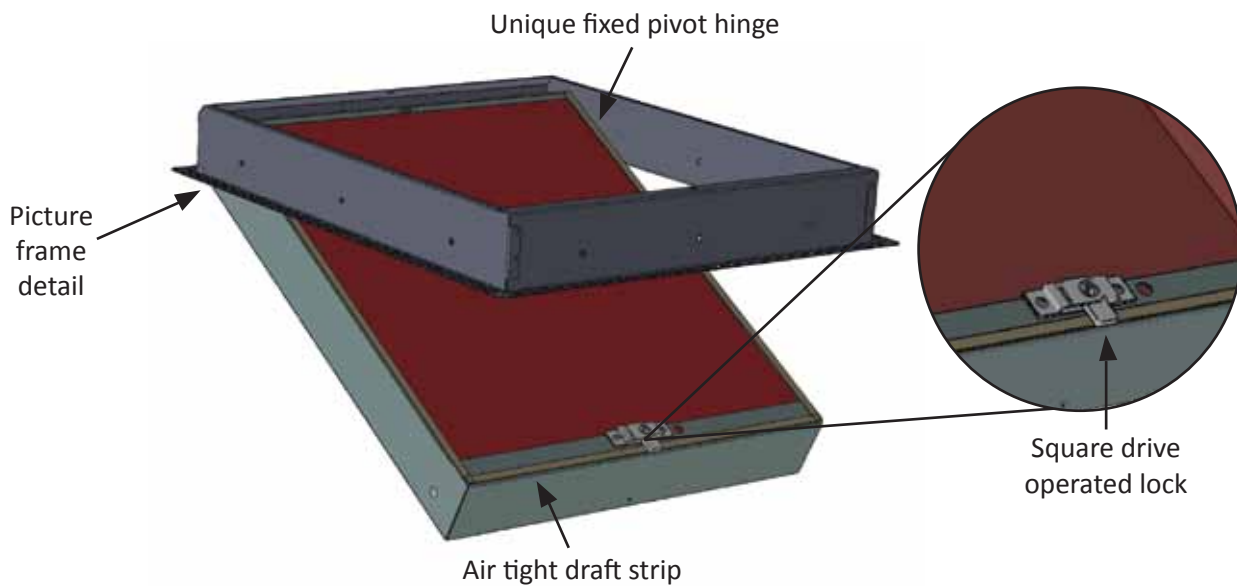

Technical & Fitting Details

n5Plus

Door tray & frame - Formed from 1.0mm and 1.2mm Zintec electro-galvanised mild steel with a 25mm wide frame either perforated or solid finished in textured polyester powder coat white RAL 9010 20% Gloss.

Hinge & lock mechanism - Factory fitted fixed screw pivot hinges located into holes in the frame or continuous piano hinge to larger panels. Square drive operated lock riveted to the return fold of the door tray with tongue locating over the back of the frame. Keyhole concealed by white plastic cap or the patented Slik Invisible keyhole system.

Fire Rating - Available with up to 1 hour fire rating. Fire testing undertaken independently by BM TRADA meeting both EN and BS standards in UKAS approved test laboratories. Certification available upon request.

Further Information - CAD DXF cross-section drawings and full technical specifications are available on request. Please call or email a member of our technical team for further information.

Availability - Standard sizes available from stock with bespoke sizes to order.

Fitting Preparation - Prepare a clear trimmed and protected opening in the structure 10mm larger than the ordered panel.

Fitting - Screw fix using suitable screws through the countersunk pre-punched holes to all four sides of the frame to all fixing points. Complete the operation with door in frame. Do not remove the door from the frame. The pivot hinged door solution must be fitted as a complete unit. Larger piano hinged doors can be removed from the frames for fitting. When refitting ensure the piano hinge nuts are tight.

Air Tightness - Thermally insulated and air-sealed options available, complying to building regulations parts L1 and L2, BS EN 12207:2000 BS EN 1026:2000.

Insulation - Thermally insulated with 100mm of high performance insulation equating to 0.35W/m³k

Acoustic Rating - Available to a maximum reduction of 63 dB Rw. Testing carried out under laboratory conditions to BS EN ISO140-3:1995 by an independent test center. More information available upon request.

Operation & Maintenance

Operation - Using the "T" key supplied push the Slik Invisible keyhole system aside, engage the key into the lock then open and close while supporting the door. The Slik system replaces itself automatically to conceal the keyhole

Maintenance - Avoid abrasive cleaning materials. Annually or more frequently if used very regularly check the operation, especially the hinge points and lock. Tighten or oil as required.

Stock Sizes

535 x 630 mm

535 x 745 mm

