

Tile Door



The Tile Door provides a high quality opening for access to building services in ceramic tiled walls. Each panel is made to suit the individual tile and combination of tiles being used. This ensures no unsightly tile cuts or visible frames disrupting the overall tiled finish. With whole tiles on the door face and no disrupted joints the panels position is then very difficult to identify.

The design utilises a continuous piano hinge that limits door sag caused by heavy tiles. This gives a stable opening arc that can be tiled to with minimum gaps between door tray and surrounding wall tiles. Once adjusted for weight the design ensures no further door drop can occur and no subsequent tile damage during operation.

The panel is finished in powder coated white or black as standard. A factory fitted specialist tile substrate is mechanically fitted into the the door tray as a base for the tiles. The door is fully removable from the frame. The panel is adjustable in all directions to level the door with the tile scheme. The door is latched with either square drive locks with sealed chrome barrels and security keys or with a touch catch mechanism.



Example of surrounding construction

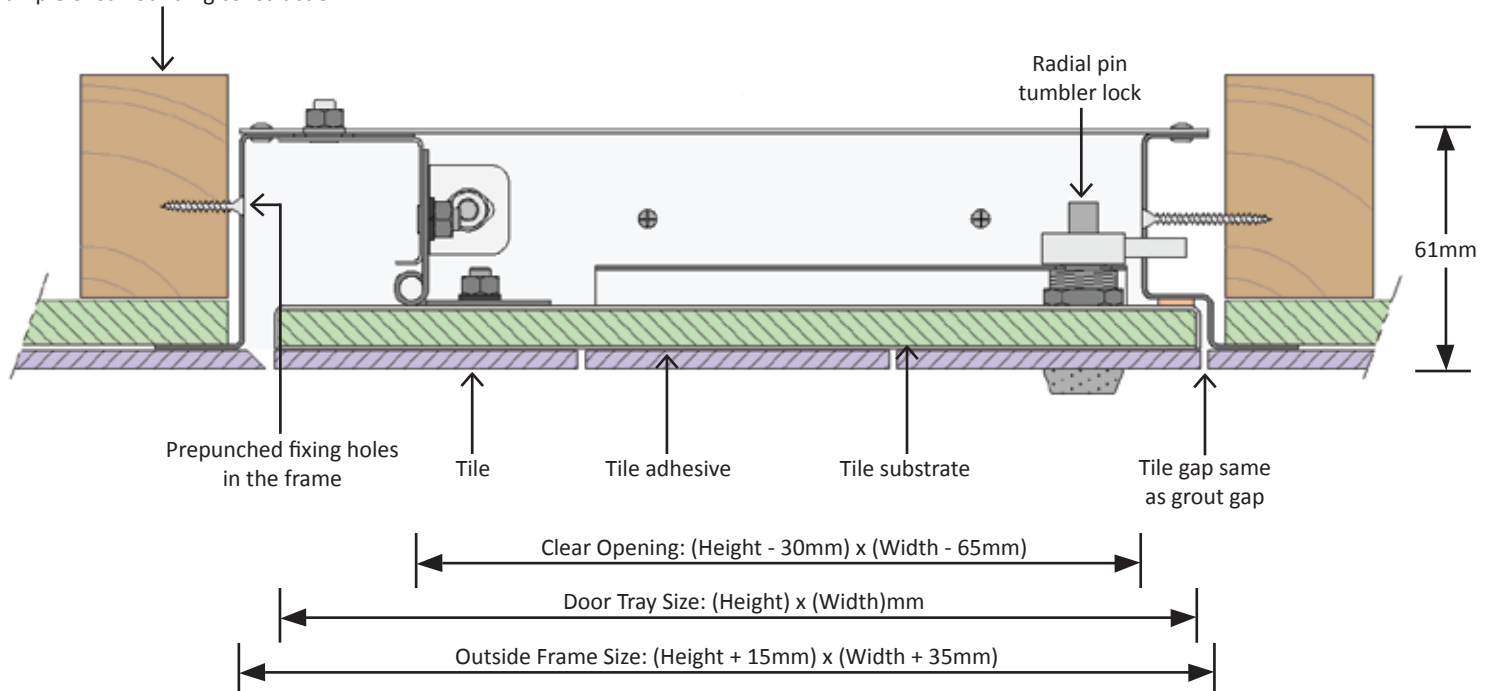

Our design office will be pleased to tailor a drawing to your exact requirements in your preferred format from 3D rendered images to line drawn DXF, DWG or other CAD formats.

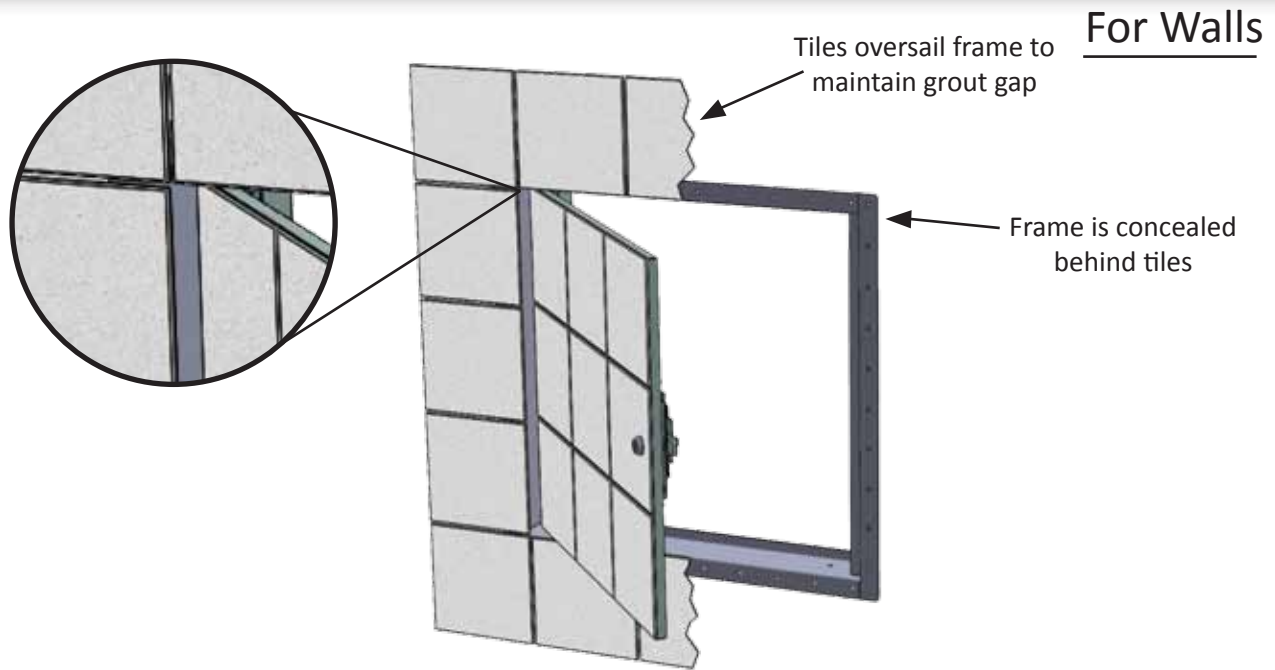

Technical & Fitting Details

n5Plus

Door tray & frame - Formed from 1.0mm and 1.2mm Zintec electro-galvanised mild steel with a 25mm wide concealed frame with pre-punched fixing points to be fixed behind the surrounding tiles. Finished in polyester powder coat white or black.

Hinge & lock mechanism - Continuous piano hinge bolted to door and frame. Square drive operated lock with sealed radial pin tumbler lock barrel to match the depth of the tiles used. Optional stainless steel escutcheon plate provided for the lock barrel. Lock tongue fits into slot in the frame. Alternatively a touch catch mechanism can be specified.

Fire Rating - Available with up to 1 hour or 2 hours fire rating. Fire testing undertaken independently by BM TRADA meeting both EN and BS standards in UKAS approved test laboratories. Certification available upon request.

Further Information - CAD DXF cross-section drawings and full technical specifications are available on request. Please call or email a member of our technical team for further information.

Availability - Each panel is made to order to suit your tile size and grout gap in approximately 5 to 9 days after approval of signed off drawings. We need the following information to create the production drawing: Tile size, H x W x D, grout gap, ideal panel size, lock type, frame option and colour.

Operation & Maintenance

Operation - Engage the key into the lock then open and close while pushing the key against the locks spring loaded sealed mechanism. For touch catch versions simply push the door.

Fitting Preparation - Prepare a clear trimmed and protected opening in the structure larger than the frame ordered as detailed on the page opposite. Ensure the panel position works with the intended tile scheme.

Fitting & Tiling - Screw fix using suitable screws through the pre-punched holes to all four sides of the frame at a minimum of 300mm intervals. Tile the door and using a 10mm spanner, adjust the door for position. It may be necessary to adjust the frame to level the tiled door tray. Tile away from the door oversailing the frame with the adjacent tiles to maintain the desired grout gap. Chamfering the adjacent hinge tile may be required depending on the tile thickness.

Air Tightness - not applicable to this range although if door to frame gap is silicone sealed in wet areas the panel will be fully air tight.

Acoustic Rating - Not available at time of printing. Other panels available to a maximum reduction of 63 dB Rw. Testing carried out under laboratory conditions to BS EN ISO140-3: 1995 by an independent test center. See Premium range Acoustic panels.

Maintenance - Avoid abrasive cleaning materials. Annually or more frequently if used very regularly check the operation, especially the hinge points and lock. Tighten or oil as required.

Stock Sizes

Tile Doors are made to measure to suit your tiles, please call our technical sales team to receive a tile door request form.

