



tenon  
PARTITIONS

# INSTALLATION GUIDE



 vitrage

The clear leader in glazed partitioning

## About this Guide

The installation guide is intended to help with the design and installation of the Vitrage range of partitioning. Suggestions on how to fit head channels, base sections and upright posts can be found through out the publication. Information on doors and door handing is provided with detailed drawings and descriptions to explain the quickest and most efficient way of installing the range of partitioning.

The installation guide has a text description, labelled cross section line drawing and in some cases a 3D rendered drawing shows possible configurations which can be used to create a stylish office environment. The guide is as descriptive as possible allowing the partitioning to be installed quickly and easily.

Safety and setting out details are included within the installation guide and a tools list is provided which could be helpful during the installation.



## Index

Safety & tools list	4
Setting out details	5 - 7
Door frame details	8
Head channel	9 - 11
Timber & glass door frames	12 - 15
Corner posts	16 - 18
Base sections	19 - 20
Conversion from solid	21 - 22
Vitrage clear dry joints	23
Vitrage gasket guide	24
General guidelines	25
Section Guide	26



## Safety

Safety is very important, please uphold all site safety regulations at all times. The use of PPE is essential to avoid injury.

Glass panels should be made visible by using a strip of tape to show that a glass panel is in place until the manifestation film is applied.

## Tools List

Listed below is a checklist of tools, which will greatly assist with the fitting of this partition system.

- chalk line/Laser
- chisels
- chop saw (with blades to cut aluminium)
- clamps (pump action)
- claw hammer
- combination square
- cordless screw gun
- drill extension pieces
- selection of files
- hacksaw
- Hoover
- padsaw
- pallet knife
- plane (block)
- plane (medium)
- pliers
- plumb line
- screw driver
- rivet gun
- roller (lambswool)
- rubber mallet
- spirit level
- knife and blades
- suitable step ladders, trestles or staging
- straight edge
- surform
- tape measure
- wallpaper spatula
- Woodsaw
- work bench



# Setting out the partition

- 1 Remove the ceiling tiles.
- 2 Mark the intended partition layout on the suspended ceiling by means of a chalk line.
- 3 Avoid excessive chalk lines which will not be covered by the finished partition.

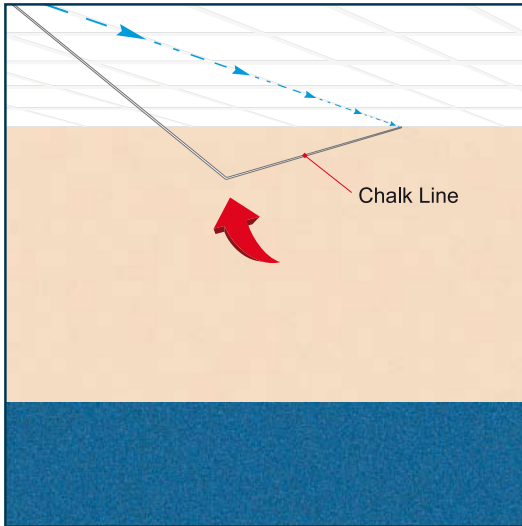

Fig. 1

Transfer the layout to the floor and wall abutments by means of a plumb line.

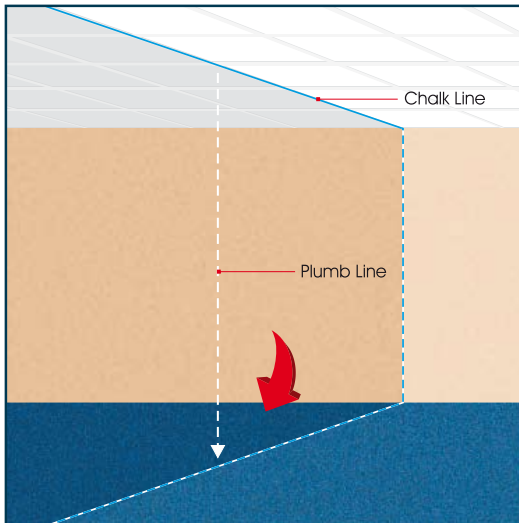
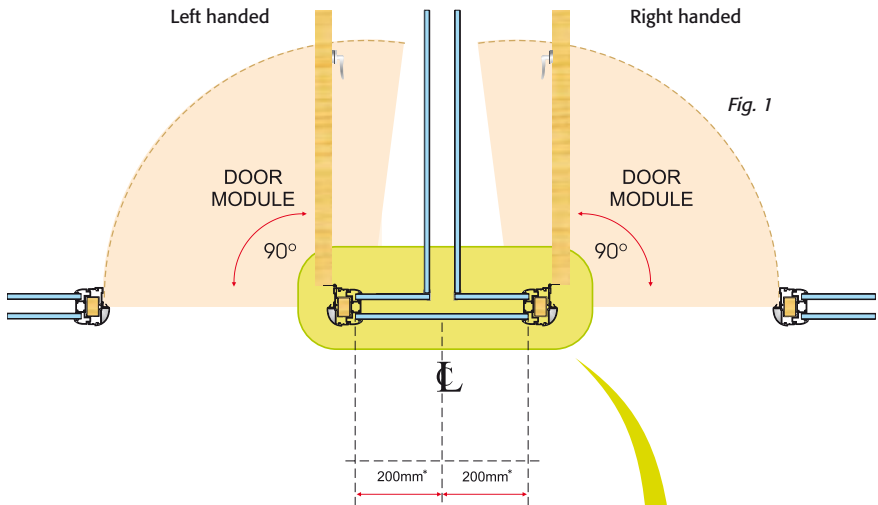

Fig. 2



## Setting out the partition (cont.)

Where the layout shows door modules adjacent to three way junctions and corners, it is recommended that a small glazed panel (200mm wide) is formed behind the door at either side of the junction, this will allow the door to fully open through 90° (see Fig. 1).



\* A minimum of 300mm from the centre line must be used for DDA compliance

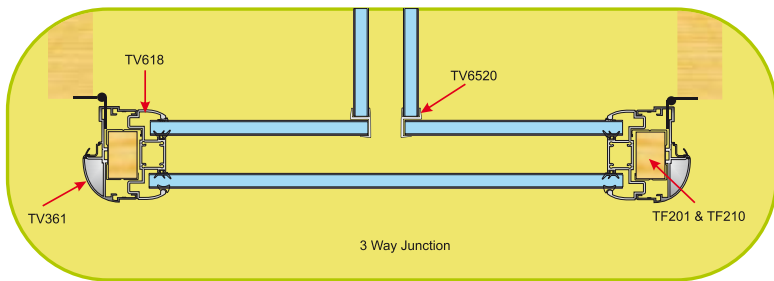

If the door frames are to be fitted directly into a three way or corner post it is important to fix an A20 floor mounted door stop to restrain the door and prevent the furniture from damaging the glass behind the door when in the 'fully open' position.

The A20 door stop should not be positioned too close to the base of the door frame as with continued use this will put undue stress on the hinge fixings. Position the door stop further back towards the leading edge of the door leaf (see Fig. 5).

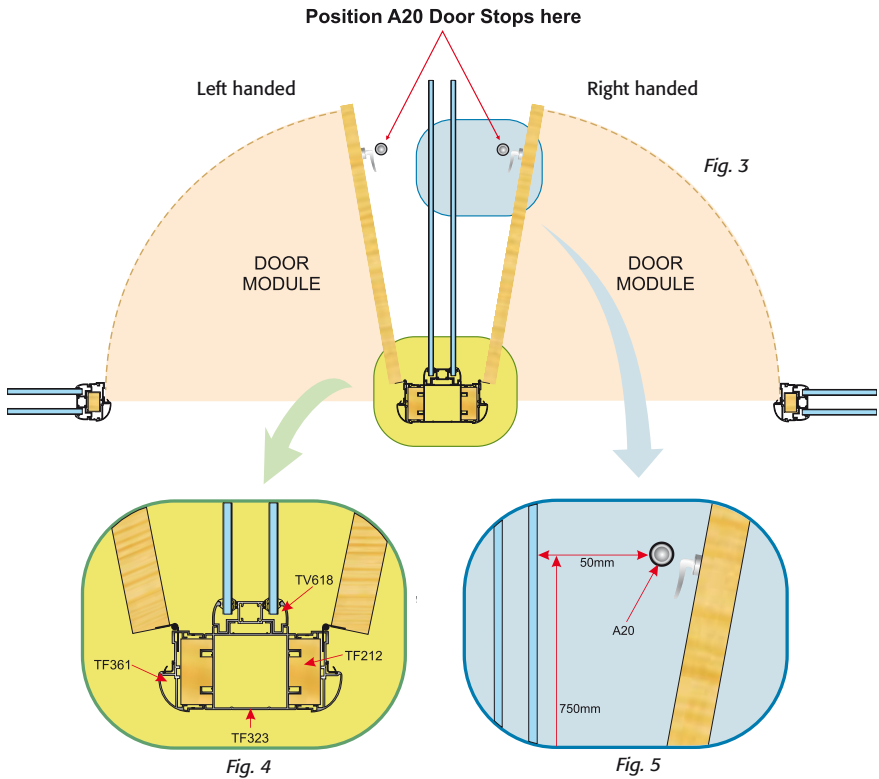

## Door modules

- 1 To avoid damage to the frame it is recommended that an “extended bit” is used to locate these screws.
- 2 Using the centre line of the strike plate as a guide, mark the position of the lock/latch and furniture and fit to the door. (this method is used for timber doors only and is not required when using glass non locking/latching doors).
- 3 Fit the door seal into the rebate in the frame (see below).

Upright post  
TV620 or TV618  
should be fitted  
to the back of the  
door frame

Door Frame

TF266  
Door Seal



Please note: The door seal is coloured black for visual purposes only. The actual colour is grey.

# Head channel details

## Double glazed head and abutment channel

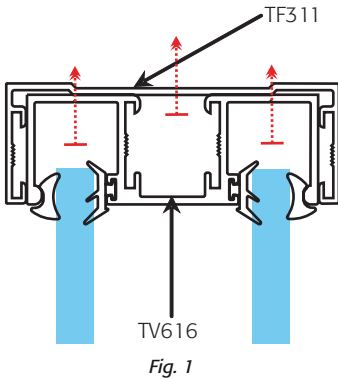

Fix through here = |.....>

### Method of build fig.1

- 1 Mark out the partitioning area using the instructions on page 5.
- 2 Measure, cut and fix TF311 head channel to the ceiling to form the run of the partitioning required.
- 3 Once TF311 is in place mark out where the door frame will be positioned within the run of partitioning then measure and cut TV616 so it overlaps the door frame by 25mm at each side.  
**Then measure and cut the internal gaskets TV681 and slot them into position, prior to fixing TV616 at staggered 600mm centres inside the TF311 head channel.**
- 4 Please note that where the partitioning changes direction the head channel should be mitred accordingly or a 90° or 135° corner post should be used.
- 5 For information on how to fit a door into this head channel configuration please see Fig. 3 on page 10.



## Head and abutment channel with door frame section for use with glass doors

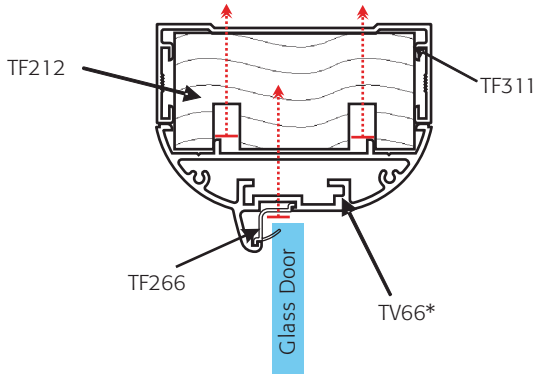

Fig. 3

Fix through here = |----->

### Method of build fig.3

- 1 Mark out the partitioning area using the instructions on page 5.
- 2 Once the TF311 & TV616 head channel are fixed in place fix three TF212 timber packers into TF311 where the TV66\* door frame head will be positioned. Once the TF212 packers are in place, fix through the door frame as shown in fig 3 above.
- 3 After fitting the base fixing bracket TV6012 and the mitre cleats to the door frame legs, fix base fixing bracket TV6012 to the floor (see page 24 for drawings of base fixing brackets). A screw hole is located 25mm in from the mitre in the door frame allowing a screw to be fixed through the door frame and into the mitre cleat locking the door frame in position.
- 4 This method of build should be repeated vertically if fitting the door frame directly to a solid wall if you are using the TF311 head channel as a wall abutment. (Please note that you will also need to order an extra three TF212 timber packers if using the TV66\* door frame with a wall abutment).
- 5 This method of build can also be used for fitting timber doors but TF36\* Fire and Sound 77mm door frame for timber doors must be used instead of TV66\* Vitrage door frame for glass doors.
- 6 For information on fitting glazing posts please see pages 12 - 18.

**\* Dependant on door height and width configuration**



## Door head fixing using timber packers

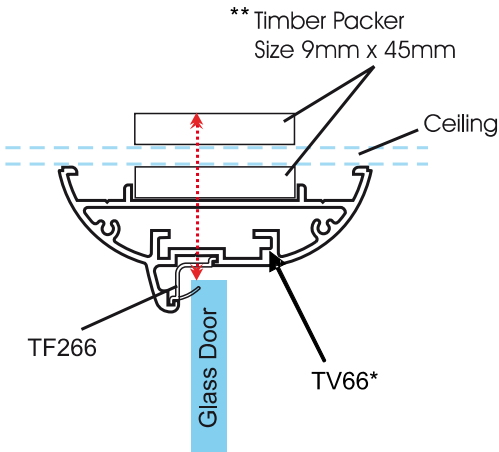

Fig. 4

**Fix through here = .....>**

### Method of build fig.4

- 1 Mark out the partitioning area using the instructions on page 5.
- 2 Mark out where the door frame will be placed within the run of partitioning
- 3 Fix timber packers to either side of the suspended ceiling above the door using the appropriate screws. Once secure fix TV66\* door frame section to the timber packers. It is advisable to use an "extended bit" to avoid damage to the door frame at this point.
- 4 When TV66\* and timber packers are fixed in place attach TF266 door seal (TF266 is included with the door frame pack) to cover up the fixing screws by placing it into the rebate of the frame.
- 5 Please refer to the door modules section for further information regarding door frame posts, doors and handing of doors on page 6 and 7.

\*\* Please note this timber packer is for use above a door frame only. It is not for use with head channel TF311 or TV616.

**\* Dependant on door height and width configuration**



# Door Frame sections for timber & glass doors

## Single glazed Vitrage with door frame for timber doors

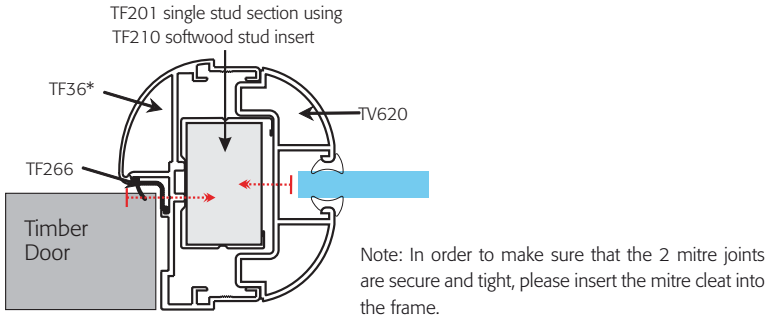

Fig. 5

Fix through here = |----->

### Method of build fig.5

- 1 Mark out where the door frame will be placed within the run of partitioning.
- 2 Position the TF36\* door head in the marked area for the door as shown in fig.4 on page 11 using the appropriate packers.
- 3 Measure the floor to ceiling height to give the height of door frame TF36\* & single glazing section TV620, cut to size. (The door frame post is pre mitred and for use with full height doors only, a door handing must be specified at time of ordering if using hinge or lock/latch fittings)
- 4 Cut to length all gaskets after referring to the gasket table on page 24 for the correct gasket to accompany the glass size being used. (Please note that a mitred corner may be used on the gaskets to provide a more desirable finish) The gaskets are then pushed in to place at the time of glazing.
- 5 Attach base fixing bracket TV6011 (A drawing of this base fixing bracket can be found on page 24) to door frame leg, then screw bracket & door frame leg to the floor using the appropriate screws, making sure the door frame leg is in the correct position based on the marking out which was done in step two.
- 6 Place TF201 & TF210 together to form the single stud section using softwood stud insert, then locate this in the centre of TF36\* & TV620 as shown in Fig. 5
- 7 When TF36\* and TV620 are fixed in place, attach TF266 door seal (TF266 is included with the door frame pack) to cover up the fixing screws by placing it into the rebate of the frame.
- 8 When the door frame leg and the single glazing section are in position, base sections TV623 & TV625 can be butted up to the single glazing section base to create the desired run length. See Fig. 13 for further information on base sections.
- 9 Head channel TV611 for single glazing can be used to butt up to the single glazing upright post TV620 to give the desired run length.
- 10 Further information on doors, door frames and door handing can be found on page 6 and 7.

**\* Dependant on door height and width configuration**



## Double glazed Vitrage with door frame for timber doors

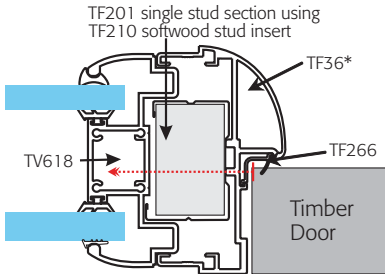
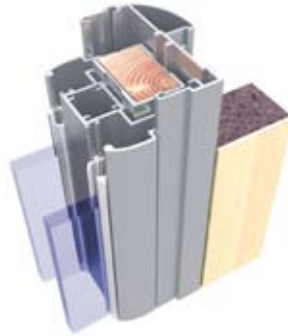

Fig. 6

Fix through here = |----->

Note: In order to make sure that the 2 mitre joints are secure and tight, please insert the mitre cleat into the frame.



### Method of build fig.6

- 1 Mark out the partitioning area using the instructions on page 5.
- 2 Once the TF311 head channel & TV616 are fixed in place fix three appropriate timber packers in to TF311 where the TF36\* door frame head will be positioned. Once the packers are in place fix through the door frame into the packers.
- 3 Measure the floor to head channel TF311 height to give the height of door frame TF36\* & double glazing section TV618, cut to size. (The door frame post is pre mitred and for use with full height doors only, a door handing must be specified at time of ordering).
- 4 Cut to length all gaskets after referring to the gasket table on page 24 for the correct gasket to accompany the glass size being used. (Please note that a mitred corner may be used on the gaskets to provide a more desirable finish) **Then slot in the internal gaskets before commencing building the framework.**
- 5 Attach base fixing bracket TV6011 (A drawing of this base fixing bracket can be found on page 24) to door frame leg, then screw bracket & door frame leg to the floor using the appropriate screws, making sure the door frame leg is in the correct position based on the marking out which was done in step two.
- 6 Place TF201 & TF210 together to form the single stud section with softwood stud insert, then locate this in the centre of TF36\* & TV618 as shown in Fig. 6
- 7 When TF36\* and TV618 are fixed in place attach TF266 door seal (TF266 is included with the door frame pack) to cover up the fixing screws by placing it into the rebate of the frame.
- 8 When the door frame leg and the double glazing section are in position, base sections TV624 & TV625 (two are required of TV625) can be butted up to the double glazing section base to create the desired run length. See Fig. 12 for further information on base sections.
- 9 Further information on doors, door frames and door handing can be found on page 6 and 7.

**\* Dependant on door height and width configuration**



## Double glazed section to Door frame for use with glass doors

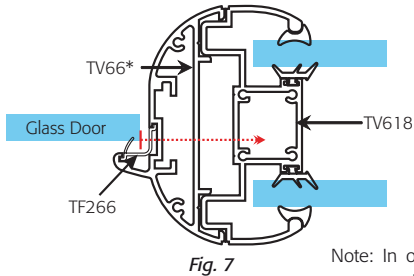

Fix through here = |----->

Note: In order to make sure that the 2 mitre joints are secure and tight, please insert the mitre cleat into the frame and screw through the holes 25mm in on the head and style to secure the cleat.

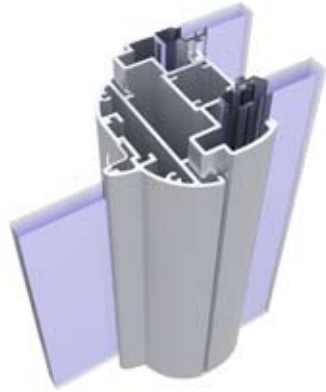

### Method of build fig.7

- 1 Mark out the partitioning area using the instructions on page 5.
- 2 Once the TF311 head channel & TV616 are fixed in place fix three TF212 timber packers in to TF311 where the TV66\* door frame head will be positioned. Once the packers are in place fix through the door frame into the packers.
- 3 Measure the floor to head channel TF311 height to give the height of door frame TV66\* & double glazing section TV618, cut to size. (The door frame post is pre mitred and for use with full height doors only, a door handing must be specified at time of ordering if using hinge or lock/latch fittings).
- 4 Cut to length all gaskets after referring to the gasket table on page 24 for the correct gasket to accompany the glass size being used. (Please note that a mitred corner may be used on the gaskets to provide a more desirable finish) **Then slot in the internal gaskets before commencing building the framework.**
- 5 Attach base fixing bracket TV6012(A drawing of this base fixing bracket can be found on page 24) to door frame leg, then screw bracket & door frame leg to the floor using the appropriate screws, making sure the door frame leg is in the correct position based on the marking out which was done in step two.
- 6 When TV66\* and TV618 are fixed in place attach TF266 door seal (TF266 is included with the door frame pack) to cover up the fixing screws by placing it into the rebate of the frame.
- 7 When the door frame leg and the double glazing section are in position, base sections TV624 & TV625 (two are required of TV625) can be butted up to the double glazing section base to create the desired run length. See Fig. 12 for further information on base sections.
- 8 Further information on doors, door frames and door handing can be found on page 6 and 7.

**\* Dependant on door height and width configuration**



## Single glazed section to Door frame for use with glass doors

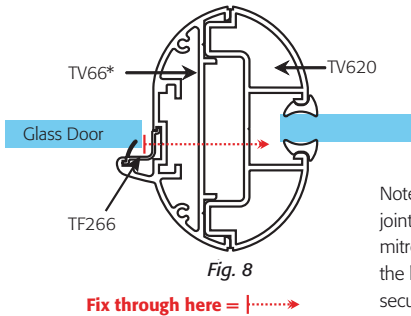

Note: In order to make sure that the 2 mitre joints are secure and tight, please insert the mitre cleat into the frame and screw through the holes 25mm in on the head and style to secure the cleat.

### Method of build fig.8

- 1 Mark out the partitioning area using the instructions on page 5.
- 2 Mark out where the door frame will be placed within the run of partitioning.
- 3 Position the TV66\* door head in the marked area for the door as shown in fig.4 using the appropriate packers.
- 4 Measure the floor to ceiling height to give the height of door frame TV66\* & single glazing section TV620, cut to size. (The door frame post is pre mitred and for use with full height doors only, a door handing must be specified at time of ordering if using hinge or lock/latch fittings).
- 5 Cut to length all gaskets after referring to the gasket table on page 24 for the correct gasket to accompany the glass size being used. (Please note that a mitred corner may be used on the gaskets to provide a more desirable finish) The gaskets are then pushed into place at the time of glazing.
- 6 Attach base fixing bracket TV6012 (A drawing of this base fixing bracket can be found on page 24) to door frame leg, then screw bracket & door frame leg to the floor using the appropriate screws, making sure the door frame leg is in the correct position based on the marking out which was done in step two.
- 7 When TV66\* and TV620 are fixed in place attach TF266 door seal (TF266 is included with the door frame pack) to cover up the fixing screws by placing it into the rebate of the frame.
- 8 When the door frame leg and the single glazing section are in position, base sections TV623 & TV625 can be butted up to the single glazing section base to create the desired run length. See Fig. 12 for further information on base sections.
- 9 Head channel TV611 for single glazing can be used to butt up to the single glazing upright post TV620 to give the desired run length.
- 10 Further information on doors, door frames and door handing can be found on page 6 and 7.

**\* Dependant on door height and width configuration**



## Double glazed section with 90° rounded corner post joining to glass door section

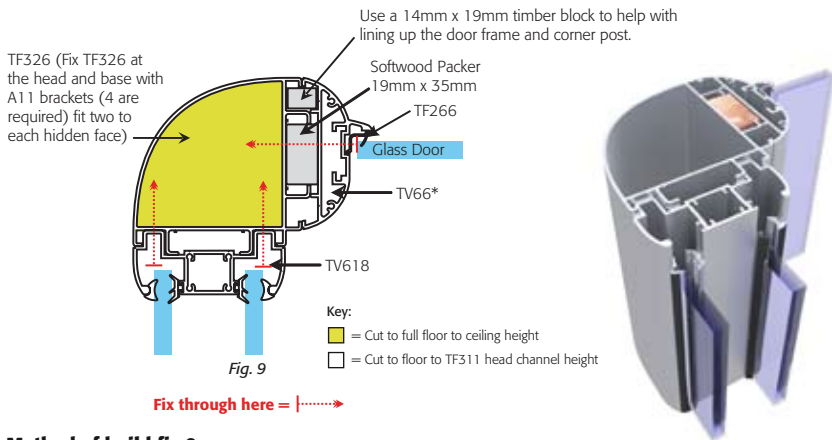

### Method of build fig.9

- 1 Mark out the partitioning area using the instructions on page 5.
- 2 Mark out where the door frame will be placed within the run of partitioning.
- 3 Measure the floor to TF311 head channel height to give the length of door frame leg TV66\*, double glazing section TV618 and cut to size. 90° corner post TF326 should be cut to full floor to ceiling height. (The door frame post is pre mitred and for use with full height doors only, a door handing must be specified at time of ordering if using hinge or lock/latch fittings).
- 4 Cut to length all gaskets after referring to the gasket table on page 24 for the correct gasket to accompany the glass size being used. (Please note that a mitred corner may be used on the gaskets to provide a more desirable finish) **Then slot in the internal gaskets before commencing building the framework.**
- 5 Attach base fixing bracket TV6012 to door frame leg (A drawing of this base fixing bracket can be found on page 24), then screw bracket & door frame leg to the floor using the appropriate screws, making sure the door frame leg is in the correct position based on the marking out which was done in step two.
- 6 Place TV66\*, TF326, TV6611 & TV618 together to form the section as shown in Fig. 9
- 7 When TV66\*, TF326, TV6611 & TV618 are in position attach TF266 door seal (TF266 is included with the door frame pack) to cover up the fixing screws by placing it into the rebate of the frame.
- 8 When the door frame leg, corner post and double glazing section are in position the base sections TV624 & TV625 (two are required of TV625) can be butted up to the double glazing section TV618 to create the desired run length. See Fig. 12 for further information on base sections.
- 9 Butt up the head channel as shown in fig.1 to the TF326 corner post.
- 10 Further information on doors, door frames and door handing can be found on page 6 and 7.

**\* Dependant on door height and width configuration**



## Single glazed section with 135° rounded corner post joining to glass door section

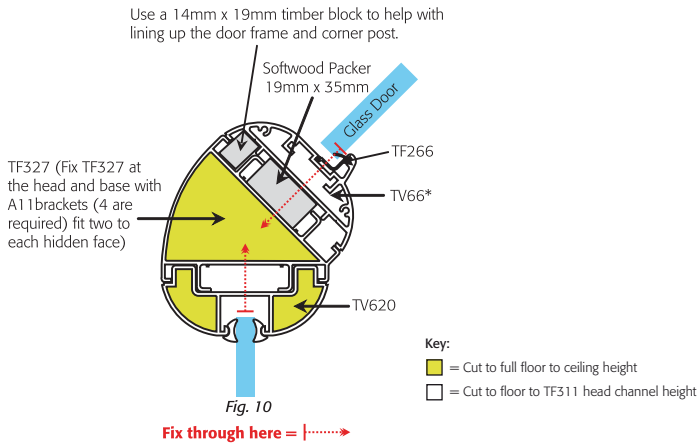

### Method of build fig.10

- 1 Mark out the partitioning area using the instructions on page 5.
- 2 Mark out where the door frame will be placed within the run of partitioning.
- 3 Measure the floor to TF311 head channel height to give the length of door frame leg TV66\* and cut to size. Single glazing section TV620 and 135° corner post TF327 should be measured to full floor to ceiling height and cut to size. (The door frame post is pre mitred and for use with full height doors only, a door handing must be specified at time of ordering if using hinge or lock/latch fittings).
- 4 Cut to length all gaskets after referring to the gasket table on page 24 for the correct gasket to accompany the glass size being used. (Please note that a mitred corner may be used on the gaskets to provide a more desirable finish).
- 5 Attach base fixing bracket TV6012 to door frame leg (A drawing of this base fixing bracket can be found on page 24), then screw bracket & door frame leg to the floor using the appropriate screws, making sure the door frame leg is in the correct position based on marking out which was done in step two.
- 6 Place TV66\*, TF327, TV6611 & TV620 together to form the section as shown in Fig. 10
- 7 When TV66\*, TF327, TV6611 & TV620 are in position attach TF266 door seal (TF266 is included with the door frame pack) to cover up the fixing screws by placing it into the rebate of the frame.
- 8 When the door frame leg, corner post and single glazing sections are in position, base sections TV623 & TV625 can be butted up to the single glazing section TV620 to create the desired run length. See Fig. 13 for further information on base sections.
- 9 Butt up the head channel as shown in fig.1 on page 8 to the TF327 corner post above the door frame. Head channel TV611 for single glazing can be used to butt up to the single glazing upright post to give the desired run length.
- 10 Further information on doors, door frames and door handing can be found on page 6 and 7.

**\* Dependant on door height and width configuration**



### 3 way post with double glazing with both timber and glass doors

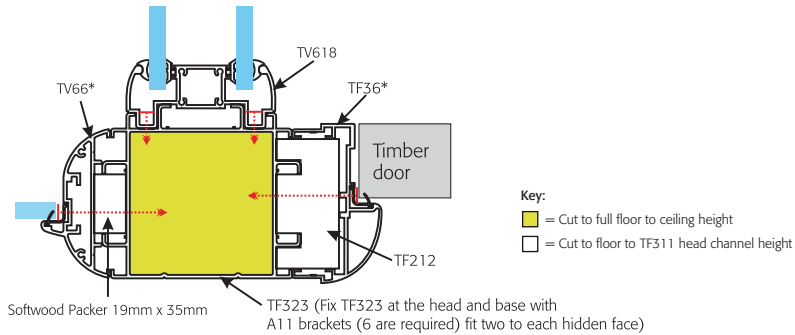

Fig. 11

Fix through here = |----->

#### Method of build fig.11

- 1 Mark out the partitioning area using the instructions on page 5.
- 2 Mark out where the door frames will be placed within the run of partitioning.
- 3 Measure the floor to ceiling height to give the length of 3 way post TF323 then cut to size. Then measure the floor to head channel height of door frame legs TV66\*, TF36\* and double glazing section TV618 and cut to size. (The door frame leg is pre mitred and for use with full height doors only, a door handing must be specified at time of ordering).
- 4 Cut to length all gaskets after referring to the gasket table on page 24 for the correct gasket to accompany the glass size being used. (Please note that a mitred corner may be used on the gaskets to provide a more desirable finish) **Place all internal gaskets into the glazing sections prior to building the framework**
- 5 Attach base fixing bracket TV6011 to door frame leg TF36\* ( A drawing of the base fixing bracket can be found on page 24), then screw bracket & door frame leg to the floor using the appropriate screws, making sure the door frame leg is in the correct position based on the marking out which was done in step two.
- 6 Fix TV66\*, TF6611, TF323, TV618, TF212 & TF36\* together to form the section as shown in Fig. 11
- 7 When TV66\*, TF6611, TF323, TV618, TF212 & TF36\* are fixed in position attach TF266 door seals (TF266 is included with the door frame pack) to cover up the fixing screws by placing it into the rebate of the frames.
- 8 When in position as in Fig.11, base sections TV624 & TV625 (Two of TV625 are required) can be butted up to the double glazing post TV618 to create the desired run length. See Fig. 12 for further information on base sections.
- 9 \*Head channel configurations shown in Fig. 1 can then be butted up to the 3 way post section TF323. (Please note that TF323 must be cut to the full floor to ceiling height so the head and base channels can be butted up to them).
- 10 Further information on doors, door frames and door handing can be found on page 6, 7 and 8.  
\*Butt up the head channel as shown in fig.1 on page 9 to all 3 sides of the TF323.

#### \*Dependant on door height and width configuration



# Base Sections

## Double glazed base/abutment channel

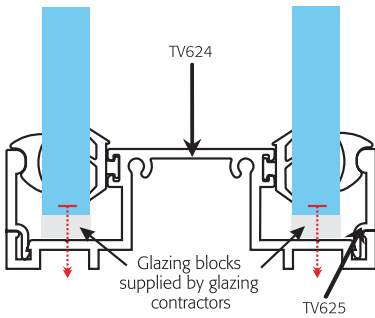
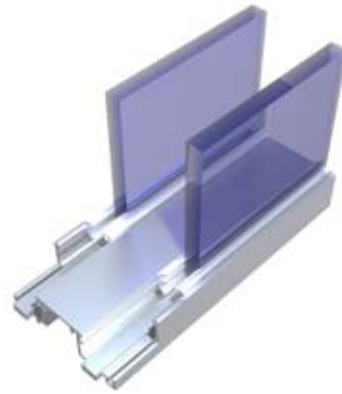

Fig. 12



Fix through here = |.....>

### Method of build fig.12

- 1 Mark out the partitioning area using the instructions on page 5.
- 2 Cut to length all gaskets after referring to the gasket table on page 24 for the correct gasket to accompany the glass size being used. (Please note that a mitred corner may be used on the gaskets to provide a more desirable finish) **Then slot in the internal gaskets before commencing building the framework.**
- 3 Cut to size TV624 double glazing base/abutment section and slot in the gaskets before commencing building the framework. Fix at staggered 600mm centres TV624 double glazing base/abutment section to the floor using countersunk Screws.
- 4 Insert both TV625 base section trims and gaskets to hold glazing in place as shown in Fig. 12. When the base section is to be run up to a door frame, put the door frame in first and then butt up the base channel from the door frame.
- 5 This base section can also be used as an abutment upright post if running the glazing from solid wall to solid wall. This allows easy installation of the glazing due to the removal of TV625.
- 6 For easy access when glazing it is advisable to put the base section down on top of the floor covering.



## Single glazing base/abutment channel

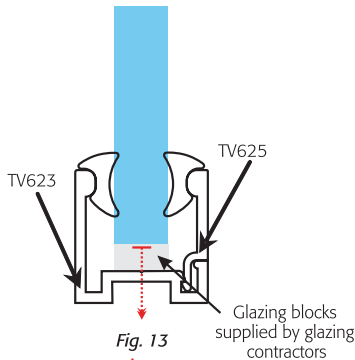

Fig. 13

Fix through here = |.....>

### Method of build fig.13

- 1 Mark out the partitioning area using the instructions on page 5.
- 2 Cut to length all gaskets after referring to the gasket table on page 24 for the correct gasket to accompany the glass size used. (Please note that a mitred corner may be used on the gaskets to provide a more desirable finish)
- 3 Cut to size TV623 single glazing base/abutment section and slot in the gaskets before commencing building the framework. Fix at staggered 600mm centres TV623 single glazing base/abutment section to the floor using countersunk Screws.
- 4 Insert TV625 base section trims and gaskets to hold glazing in place as shown in Fig. 13. When the base section is to be run up to a door frame, put the door frame in first and then butt up the base channel to the single glazing post TV620.
- 5 This base section can also be used as an abutment upright post if running the glazing from solid wall to solid wall. This allows easy installation of the glazing due to the removal of TV625.
- 6 For easy access when glazing it is advisable to put the base section down on top of the floor covering.

# Conversion from solid - double/single

## Double glazed conversion to solid section 75mm only

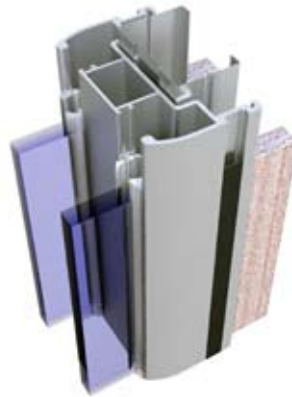
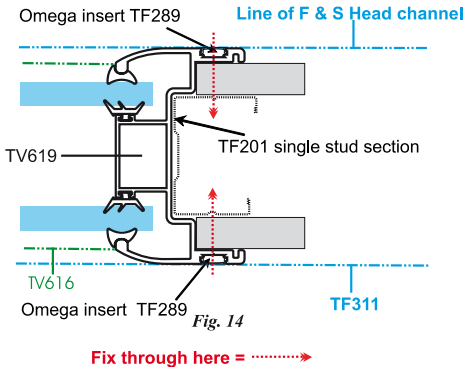

### Method of build fig.14

- 1 Mark out the partitioning area using the instructions on page 5.
- 2 Mark out where the solid 75mm will stop and the double glazing will start within the run of partitioning (or visa versa)
- 3 Measure the floor to TF311 head channel height to give the length of conversion post TV619 and cut to size.
- 4 Cut to length all gaskets after referring to the gasket table on page 24 for the correct gasket to accompany the glass size used. (Please note that a mitred corner may be used on the gaskets to provide a more desirable finish) **Then slot in the internal gaskets before commencing building the framework.**
- 5 When TV619 is in position cut to length TF289 Omega insert and press into the insert channel as shown in Fig. 14 (An order for TF289 must be placed at the time of ordering the main materials for the partitioning).
- 6 When TV619 is in position, base sections TV624 & TV625 (two are required of TV625) can be butted up to the double glazing to solid conversion post TV619 to create the desired run length. See Fig. 12 for further information on base sections.
- 7 Head channel configurations shown in Fig. 1 can then be run over the double glazing to solid conversion post TV619. (Please note that TV619 must be cut to the floor to TF311 head channel height so the head can run over the top in to the solid)



# Conversion from solid - single

## Single glazed conversion to solid section 75mm only

### Single glazed conversion to solid section 75mm only

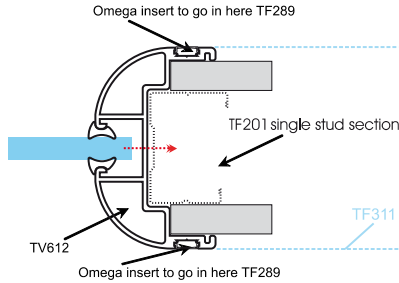

Fig. 15

Fix through here = .....>

### Method of build fig.15

- 1 Mark out the partitioning area using the instructions on page 5.
- 2 Mark out where the solid 75mm will stop and the single glazing will start within the run of partitioning (or visa versa)
- 3 Measure the floor to ceiling height to give the length of conversion post TV612 and cut to size.
- 4 Cut to length all gaskets after referring to the gasket table on page 24 for the correct gasket to accompany the glass size being used. (Please note that a mitred corner may be used on the gaskets to provide a more desirable finish)
- 5 When TV612 is in position cut to length TF289 Omega insert and press into the insert channel as shown in Fig. 15 (An order for TF289 must be placed at the time of ordering the main materials for the partitioning).
- 6 When TV612 is in position, base sections TV623 & TV625 can be butted up to the single glazing to solid conversion post TV612 to create the desired run length. See Fig. 13 for further information on base sections.
- 7 Single glazing head channel TV611 can then be butted up to the single glazing to solid conversion post TV612. (Please note that TV612 must be cut to the full floor to ceiling height so the head and base channels can be butted up to it)



# Vitrage Clear Dry Joints

## Double glazed 90° corner clear dry joints

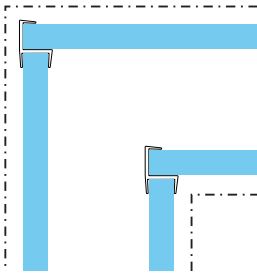

Fig. 16

## Double glazed 180° clear dry joint with 3 way single glazed clear dry joint

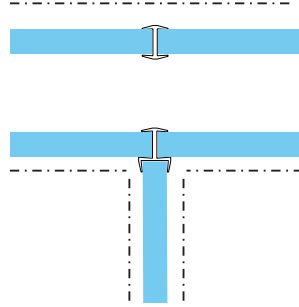

Fig. 19

## Double glazed 'T' section clear dry joints 90°

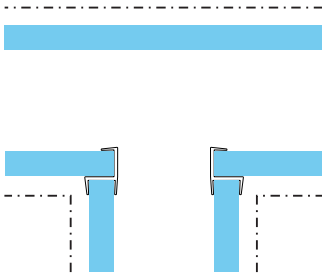

Fig. 17

## Double glazed angled corner clear dry joints

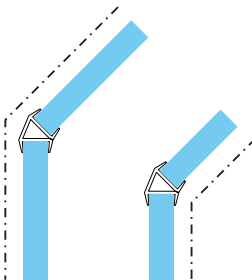

Fig. 18

### Clear Dry Joint sections



For use with 10mm or 10.8mm glass

TV6400  
(826902)



TV6420  
(839602)



For use with 12mm or 12.8mm glass

TV6500  
(3002802)

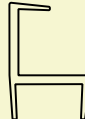

TV6520  
(3002902)



For use with 10mm or 10.8mm glass

TV6440  
(3002702)



TV6460  
(839602)



For use with 12mm or 12.8mm glass

TV6540  
(995702)



TV6560  
(3002902)



## Base Fixing Brackets



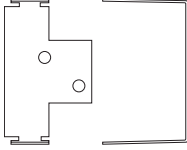



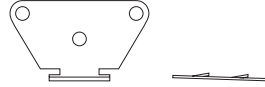





Base fixing bracket TV6011 for use with Tenon Fire & Sound door frames



Base fixing bracket TV6012 for use with Tenon Vitrage door frames

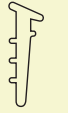
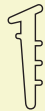

## Vitrage Gasket Table

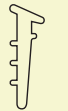
Double Glazing	Glass Sizes	Single Glazing
 Outer Gasket TV881 (610201)	 Inner Gasket TV681 (3264)	10mm Toughened Glass   TV881 TV881
 Outer Gasket TV881	 Inner Gasket TV681	10.8mm Laminated Glass   TV881 TV881
 Outer Gasket TV682 (931002)	 Inner Gasket TV681	12.0mm Toughened Glass   TV682 TV682
 Outer Gasket TV682	 Inner Gasket TV681	12.8mm Laminated Glass   TV682 TV682

All TV681 inner gaskets should be fitted in to the profile before assembly and the two top fins should be facing upwards as shown in the gasket table above.



# General Guidelines:

- Frame finish: Available painted as standard Tenon BS or RAL colours, other colours are available on longer lead times
- Vitrage door frame packs  
TV661 single door frame will comprise of the following:
  - 2 x TV660 styles up to 2900mm long
  - 1 x TV660 head to suit 900mm wide
  - 20 x FF2438 38x3.5 self tapping csk screws bzp
  - 2 x mitre cleats (from Ovation range)
  - 2 x TF266 x 3000mm door buffer
  - 1 x TF266 x 2100mm door buffer
  - 2 x TV6012 floor brackets
  - 1 x milling for lock plate
  - 1 x lock plate with 2 screws
  - 1 x special milling at head for pivot
  - 3 x TF212 timber packer  
TV662 double door frame will comprise of the following
  - 2 x TV660 styles up to 2900mm long
  - 1 x TV660 head to suit 1800mm wide
  - 20 x FF2438 38x3.5 self tapping csk screws bzp
  - 2 x mitre cleats (from Ovation range)
  - 2 x TF266 x 3000mm door buffer
  - 1 x TF266 x 2100mm door buffer
  - 2 x TV6012 floor brackets
  - 2 x special milling at head for pivot
  - 3 x TF212 timber packer
- Glass heights  
Class A safety glass must be used for fully glazed partitioning. Both 10mm and 12mm toughened (or 10.8mm and 12.8mm laminated glass) glass comply but 12mm glass provides greater stability. The table below shows the generally accepted height to thickness ratios.  
  
Up to 2500mm - 10mm Toughened  
2500mm - 2700mm - 10mm or 12mm Toughened  
2700mm - 2900mm - 12mm Toughened  
  
Single glazed Vitrage is generally glazed using 10mm glass up to a height of 2700mm unless specified.
- Vitrage (dB)  
It is the responsibility of the contractor to install the perimeter framework.
- Manifestation  
Doc M 2004 states manifestation should be positioned at a minimum height of 850mm to 1000mm from the base and from the top of the partitioning 1400mm to 1600mm.



## Aluminium framing sections are available in a range of standard colours: -

RAL 5010 Gentian Blue	RAL 9010 Pure White	RAL 5012 Light Blue
RAL 9016 Traffic White	RAL 6005 Moss Green	BS: 00 A 05 Light Grey
RAL 7011 Iron Grey	BS 04 E 53 Geranium Red	RAL 9005 Jet Black
BS 08 B 15 Magnoli	BS 08 B 29 Van Dyke Brown	RAL 9006 Silver

BS4800 and RAL colours which are not included in the above list are also available, subject to additional cost. Please enquire about lead times on specific finish required.







### Acoustic test overview:

Vitrage Single Glazed: Up to 38dB (Rw)







Vitrage (dB) Double Glazed: Up to 47dB (Rw)

### Section Summary:

#### Vitrage - single glazing:

	TV611 – Aluminium head channel/wall abutment section
	TV615 – Aluminium infill/capping section for use with TV611
	TV612 – Vitrage S/G to 77 mm Fire & Sound/Solid conversion post
	TV625 – Two part base section trim for use with TV623 or TV624
	TV623 – Single glazing two part base section use with TV625
	TV614 – Aluminium base angle
	TV620 – Aluminium S/G doorframe post
	TV661 – 2700 x 900 x 10/12mm single door frame pack
	TV662 – 2700 x 1800 x 10/12mm double door frame pack

#### Vitrage (dB) – Double Glazing:

	TV616 – Aluminium D/G head channel/wall abutment section
	TV624 – Double glazing two part base section use with TV625
	TV618 – Aluminium D/G doorframe post
	TV619 – Vitrage D/G to 77 mm Fire & Sound/Solid conversion post
	TV681 – Inner gasket for use with D/G
	TF311 – 77mm Fire & Sound head channel (for use with TV616)



**Vitrage Accessories - single or double glazing:**

	TV881 – Clear wedge gasket for use with 10/10.8mm glass
	TV682 – Clear wedge gasket for use with 12/12.8mm glass
	TV6400 – 180 degree clear dry joint for 10/10.8mm glass
	TV6500 – 180 degree clear dry joint for 12/12.8mm glass
	TV6420 – 90 degree clear dry joint for 10/10.8mm glass
	TV6520 – 90 degree clear dry joint for 12/12.8mm glass
	TV6440 – 135 degree clear dry joint for 10/10.8mm glass
	TV6540 – 135 degree clear dry joint for 12/12.8mm glass
	TV6460 – 90 degree 3 way clear dry joint for 10/10.8mm glass
	TV6560 – 90 degree 3 way clear dry joint for 12/12.8mm glass

## Notes

---

---

---

---

---

---

---

---

---

---





A product of  
CPD Distribution Plc,  
17 Europa View,  
Sheffield Business Park,  
Sheffield, S9 1XH

Tel: 08701 229945  
Fax: 08701 229951



[www.tenonpartitions.co.uk](http://www.tenonpartitions.co.uk)

© Copyright and Design right. CPD Distribution plc 2008  
Vitrage is a Registered Trademark of CPD Distribution plc.



CPD08/1105

Printed on chlorine free paper  
50% recycled, 50% well managed forest

