

focus

application guide

11.26.2018



teknion

contents

INTRODUCTION	3
WHAT IS FOCUS?	23
FRAMES & TRIMS	41
FASCIAS	49
DOORS	61
WALL STARTS & WALL ENDS	81
WALL TRANSITIONS	91
GLASS CONNECTORS	101
ACCESSORIES & ELECTRICAL	105
CLERESTORY	109

introduction

introduction

WHERE TO FIND THE INFORMATION YOU NEED	5
HOW TO MAKE THIS GUIDE WORK FOR YOU	6
PRODUCT MAP	8

where to find the information you need

Teknion provides an array of tools and information resources to help you get things done simply and easily. From product pricing to application guidelines to online planning suggestions, you will find what you need when you need it.

product pricing

Online Access to all current pricing in PDF format, can be found at www.teknion.com, by selecting the **products** tab, the desired product line and then **pricing module**.

Printed Price Guides by product line containing product maps, detailed pricing tables and product basics information are available to help you specify correctly. These guides can be ordered online through www.teknion.com, by selecting the **tools** tab and then **print on demand** or by contacting your local Teknion Representative.

application guidelines

Online Access to all current Application Guides in PDF format, can be found at www.teknion.com, by selecting the **tools** tab, **application guides** and the desired product line.

Printed Application Guides by product line containing detailed application guidelines as well as tips to help you plan and specify each of our products are available. These guides can be ordered online through www.teknion.com, by selecting the **tools** tab and then **print on demand** or by contacting your local Teknion Representative.

planning tool

Select and view typicals of our products by setting, product, or footprint. Get great ideas and save time!

Online Access is available on www.teknion.com, by selecting the **tools** tab and then **planning tool**.

weights & volumes

Online Access to Weights & Volumes are available on www.teknion.com, by selecting the **products** tab and the desired product line. Download Weights & Volumes.

fabrics & finishes

Teknion's Fabrics and Finishes offering includes the following programs; Finishes + Materials and Teknion Textiles.

Online Access is available on www.teknion.com, by selecting the **tools** tab and then **Fabrics & Finishes**.

Printed Fabrics & Finishes Guides can be ordered online through www.teknion.com, by selecting the **tools** tab and then **print on demand** or by contacting your local Teknion Representative.

product photography & drawings

Online Access to all photos, line drawings and renderings are available on www.teknion.com, by selecting the **tools** tab and selecting either **photography**, **CAD symbols** or **Sketchup 3D Warehouse**.

order forms

All forms (COM Request, TekniPaint and TekniStain forms) are available online at www.teknion.com, by selecting the **tools** tab and then **Fabrics & Finishes**. Download the form you require.

warranty/terms & conditions of sale

Online Access is available on www.teknion.com, by selecting the **Legal & Warranty** link located on the footer of the website.

installation guides

Installation Guides are available for both Online and Print. Contact your Teknion Customer Service Representative for more details.

user feedback

How is our marketing material working for you?

Feedback from the user is very important to the quality of Teknion's marketing material. We ask that if you have suggestions on how you think we could improve content OR if you have found an error, that you please contact your Teknion Technical Services department.

how to make this guide work for you

application guide contents

This guide contains detailed application and planning information to help you plan your project correctly. The Introduction section provides everything you need to get started and the subsequent sections provide application information by product type. Each of these sections contains detailed specification guidelines, application and planning information to help you plan your project correctly.

6

application guide
Introduction
Overall Product Map
Overview and Basics by section
Planning Details by section

basics page at a glance

For pricing details refer to the appropriate Price Guides available on www.teknion.com.

frames & trims

single frame assembly basics

Single frame assemblies allow for a single 10mm or 12mm glass fascia to be mounted in the center or offset location of a frame.

Single Centered Frame Assembly - Ceiling (FWCC)

Single Centered Frame Assembly - Base (FWCB)

Frame finishes: Clear Anodized and Painted

- Extrusions are available in nominal widths from 12" to 120" with the ability to specify to 1/16" increments
- Extrusions are available in three conditions
 - Angled
 - Three-way mitted
 - Four-way mitted
- When specifying extrusions a left and right angled increment must be selected
- The increments represent the two extrusion angles (when viewed from the exterior) required to make up the overall planning angle required

Single Centered Frame Assembly - Ceiling (FWCC)
• Adjustable ceiling frame for single centered glass fascia

Single Centered Frame Assembly - Base (FWCB)
• Adjustable base frame for single centered glass fascia
• Safety corners are used to soften corner edges, for more information see the Accessories & Electrical section

Single Offset Frame Assembly - Ceiling (FWOC)
• Adjustable ceiling frame for offset single centered glass fascia

Single Offset Frame Assembly - Base (FWOB)
• Adjustable base frame for offset single centered glass fascia
• Safety corners are used to soften corner edges, for more information see the Accessories & Electrical section

43

focus application guide - November 28, 2018

Section Title

Page Title

Product Overview Statement

Page Number

Product Name and Code, application notes, dimensions and finishes (as applicable)

Last update for this page

how to make this guide work for you (continued)

application guideline details at a glance

Section Title → frames & trims

Page Title → planning with horizontal frames

Page Number → 46

Last update for this page → focus application guide – November 28, 2018

Product Overview Statement

The following describes the floor to ceiling leveling accommodation provided by Focus horizontal frames.

- If the site is in a pre-constructed condition, the nominal floor to ceiling height can be specified. In this case the nominal floor to ceiling height must be kept within $\pm 1/8"$ over 10'-0"
- If the site is in a constructed condition, the nominal floor to ceiling height is determined through site measurements and specification software
- Based on the nominal floor to ceiling height, base and ceiling frame have an overall leveling range of 30mm (+19mm / -11mm)
 - Ceiling frame has an overall levelling range of 15mm (+8mm / -7mm)
 - Base frame has an overall levelling range of 15mm (+11mm / -4mm)

Planning and/or application details

FF - Finished floor

additional information

The following forms are available at www.teknion.com, by selecting the **tools** tab and then **Fabrics & Finishes**, to help you specify and place your order if required:

teknipaint

If you require a custom paint color match, you must submit a TekniPaint form.

using your own material (COM)

If you wish to use your own material on fabric-covered products, you must submit a completed COM form including a sample upholstery and safety testing.

A COM Order Information Sheet must also be submitted. This form captures all relevant ordering and tracking information.

A COM Request for Yardage Calculation form may be sent to Teknion for preliminary yardage requirements.

placing a manual order

Complete an Order Cover Sheet with the information we need to fill your order. This is the most important step. If the Order Cover Sheet is not complete and correct, the order may be delayed.

noting key requirements

If you require that certain pieces share the same locks you will need to specify Set of Keys Alike (SOKL) located in the Price and Product Guide.

frames & trims

F W C C Single Centered Frame Assembly – Ceiling

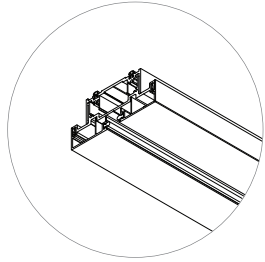

F W C B Single Centered Frame Assembly – Base

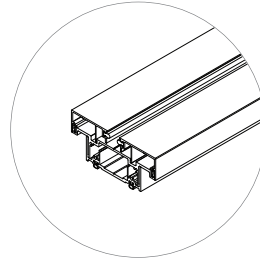

8

F W O C Single Offset Frame Assembly – Ceiling

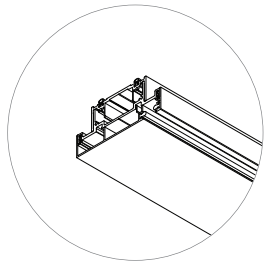

F W O B Single Offset Frame Assembly – Base

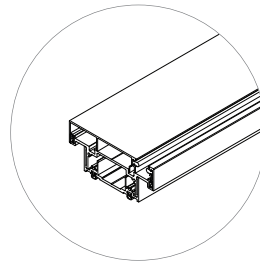

F W D C Double Frame Assembly – Ceiling

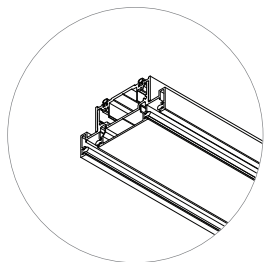

F W D B Double Frame Assembly – Base

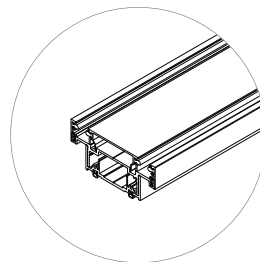

F W S C Solid Frame Assembly – Ceiling

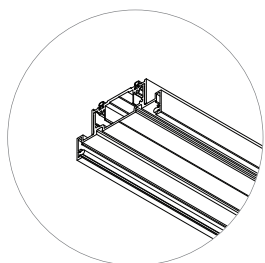

F W S B Solid Frame Assembly – Base

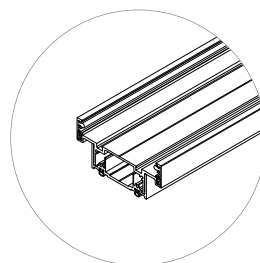

frames & trims

F W S S G H Solid to Single Glass –
Horizontal Extrusion Trim

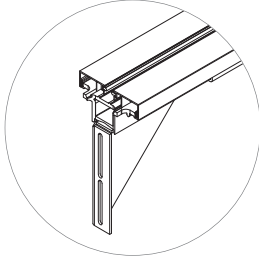

F W S D G H Solid to Double Glass –
Horizontal Extrusion Trim

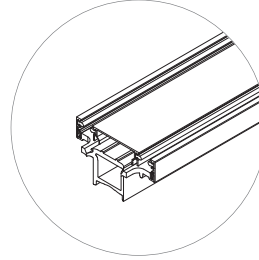

fascias

F W G A Glass Fascia – 10mm Thickness



F W G B Glass Fascia – 12mm Thickness



F W G S A Glass Fascia Clerestory – 10mm Thickness

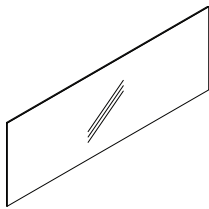

F W G S B Glass Fascia Clerestory – 12mm Thickness

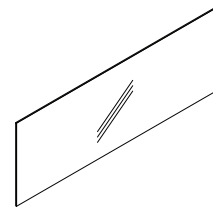

F W S 1 Solid Fascia

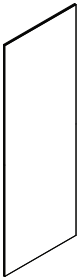

F W S 3 Solid Fascia – 18" Height Cut Out

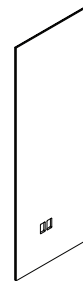

F W E P Electrical Filler Panel Fascia



F W I Insulation

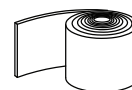

F W H D S Glass Hinged Door

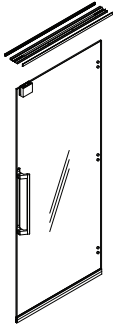

F W S D S Solid Hinged Door

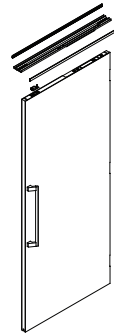

F W P D S Single Glazed Pivot Door

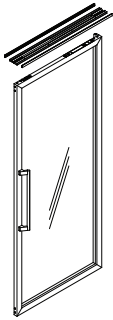

F W D D S Double Glazed Pivot Door

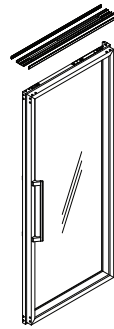

F W P D D Single Glazed Pivot Door – Double

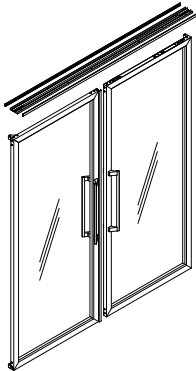

F W B D S I Single Glazed Sliding Door – Infinite Frame



F W H S F Glass Hinged Door Single Frame

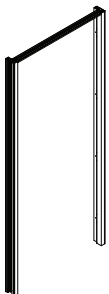

F W S S F Solid Hinged Door Single Frame



doors

F W P S S F Single Glazed Pivot Door Single Frame

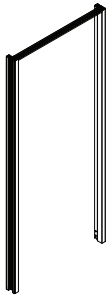

F W P S D F Single Glazed Pivot Door Double Frame

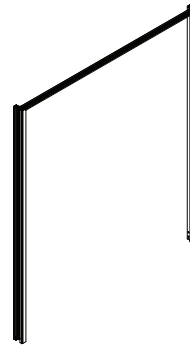

I2

F W P D S F Double Glazed Pivot Door Single Frame

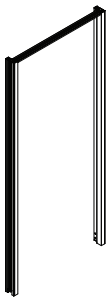

F W S B I F Single Glazed Sliding Door Infinite Frame – Single

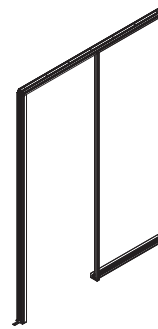

F W D B I F Double Glazed Sliding Door Infinite Frame – Single

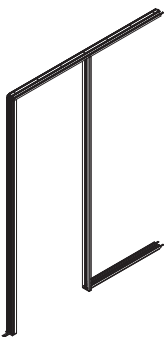

wall starts & wall ends

F W W G S Wall Start Single Centered Glass

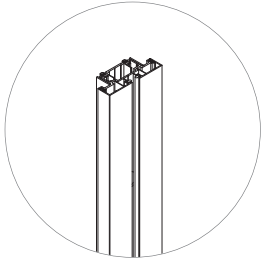

F W W G O Wall Start Single Offset Glass

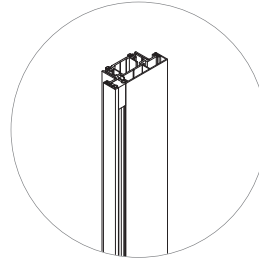

F W W G D Wall Start Double Glass

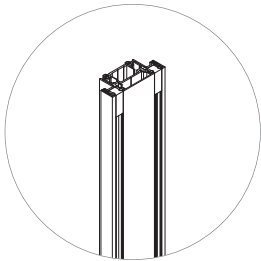

F W W S D Wall Start Solid

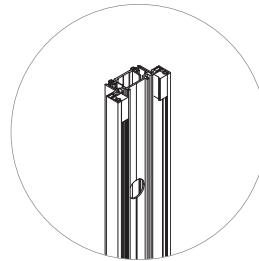

F W W D G S Wall Door Start Single Centered Glass

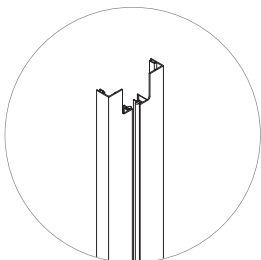

F W W D G O Wall Door Start Offset Glass

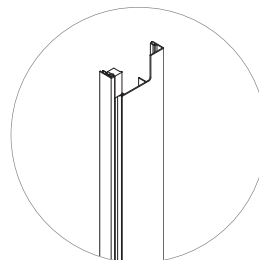

F W W D G D Wall Door Start Double Glass

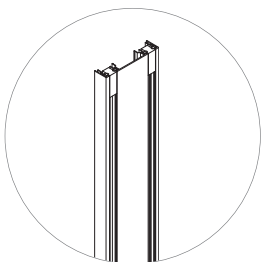

F W W D S D Wall Door Start Solid

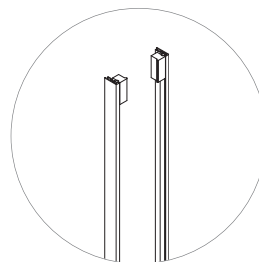

wall starts & wall ends

F W W H D Wall Start Door

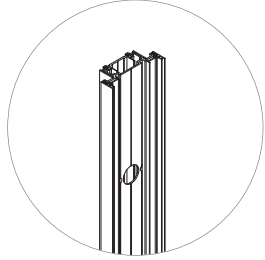

F W W E Wall Start Electrical

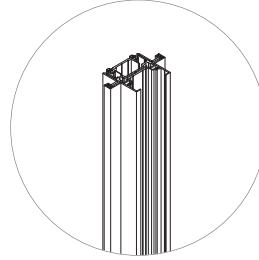

I4

F W W C Wall End Inline Single Centered Glass

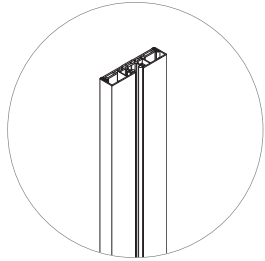

F W W O Wall End Inline Offset Glass

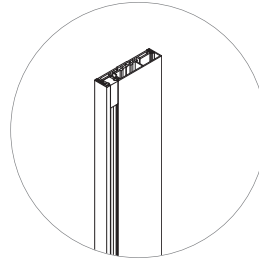

F W W D Wall End Inline Double Glass

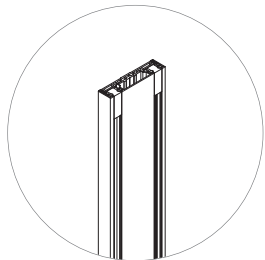

F W W S Wall End Inline Solid

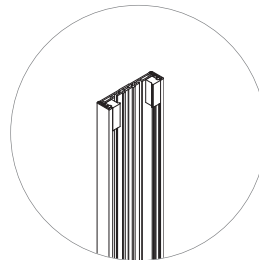

F W T I D Wall End Inline Door

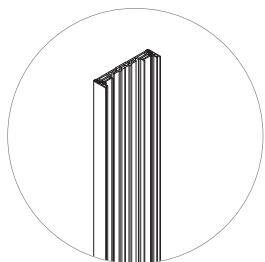

F W T I E Wall End Inline Electrical

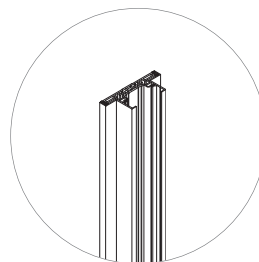

wall starts & wall ends

F W W G S F Wall Start Single Centered Glass – Framed

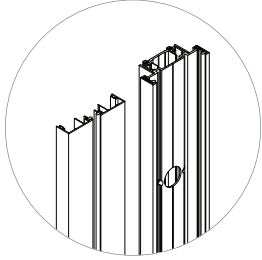

F W W G D F Wall Start Double Glass – Framed

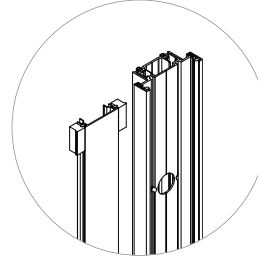

F W W D G S F Wall End Single Centered Glass – Framed

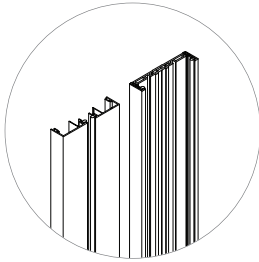

F W W D G D F Wall End Double Glass – Framed

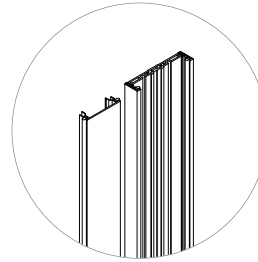

wall transitions

F W T E Wall Transition Electrical

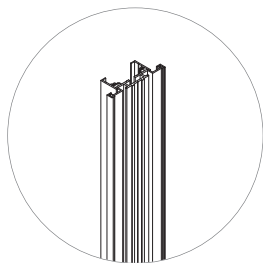

F W D E Door Transition Electrical

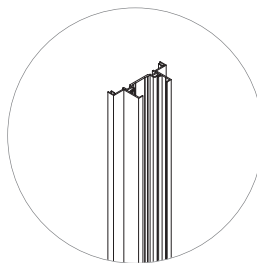

16

F W T C D Corner Transition

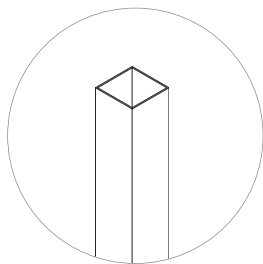

F W T D G O Corner Double Glass or Solid to Single Offset Glass Connection

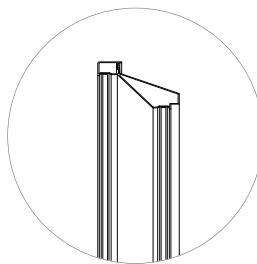

F W T D G S Corner Double Glass or Solid to Single Centered Glass Connection

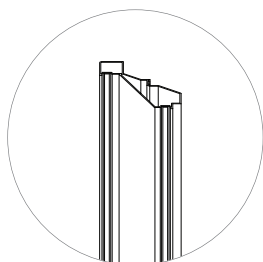

F W T D S Corner Double Glass or Solid to Solid Connection

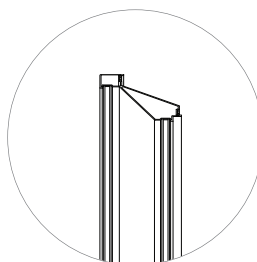

F W I T S S Inline Transition Connection – Solid to Solid

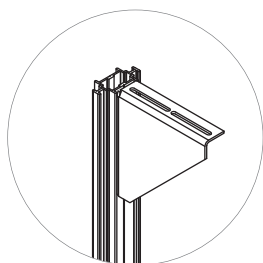

F W T I S G D Inline Transition Connection – Solid to Double Glass

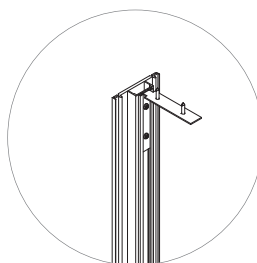

wall transitions

F W T I S G S Inline Transition Connection –
Solid to Single Glass

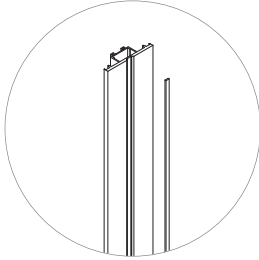

F W T I G S G S Inline Transition Connection – Single
Glass to Single Glass

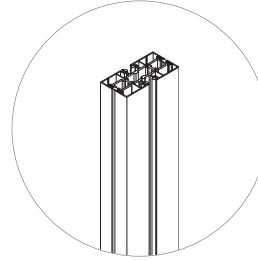

F W T I G S G O Inline Transition Connection – Single
Centered Glass to Single Offset Glass

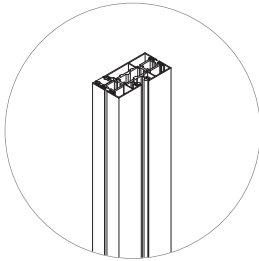

F W T I G O G O Inline Transition Connection – Offset
Glass to Offset Glass

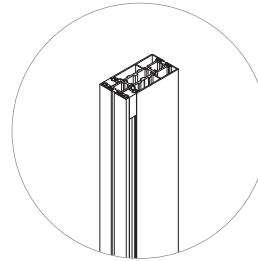

F W T I G D G S Inline Transition Connection –
Double Glass to Single Glass

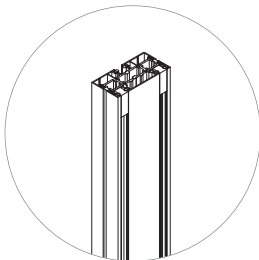

F W T I G D G O Inline Transition Connection –
Double Glass to Offset Glass

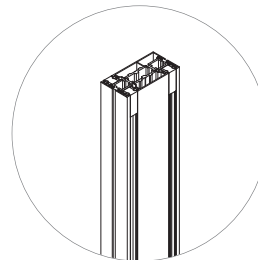

F W T I G D G D Inline Transition Connection –
Double Glass to Double Glass

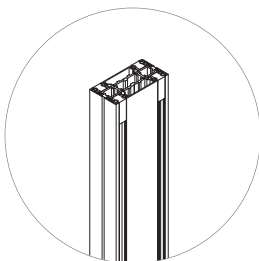

F W I T S S F Inline Transition Connection –
Framed Condition – Solid to Solid

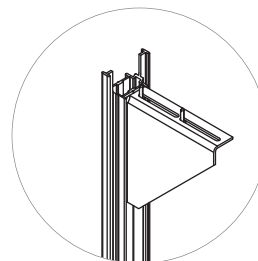

wall transitions

F W T S G D F Inline Transition Connection –
Framed Condition – Solid to Double
Glass

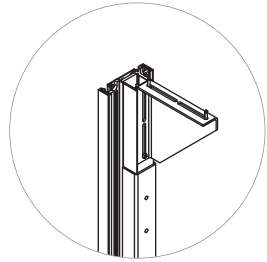

F W T S G S F Inline Transition Connection –
Framed Condition – Solid to Single
Centered Glass

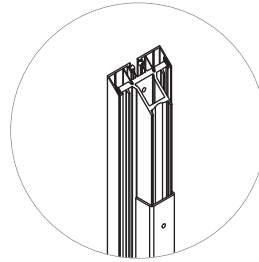

F W T I F A Inline Transition Connection –
Focus to Altos

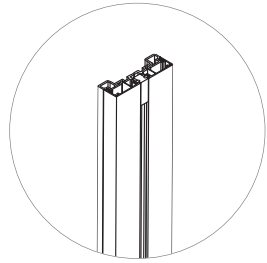

glass connectors

F W I P Glass Connector Kit – Inline Clear Plastic

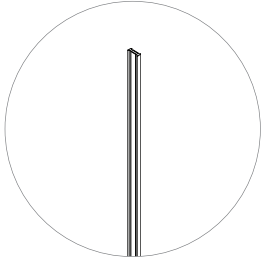

F W I A Glass Connector Kit – Inline Aluminum

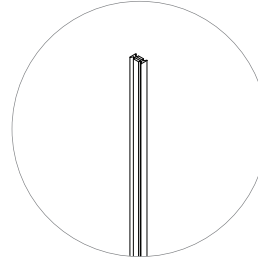

F W I T Glass Connector Kit – Inline Tape

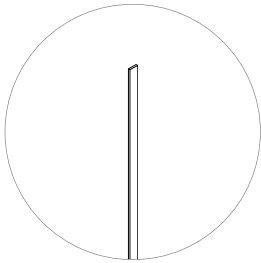

F W I V Glass Connector Kit – Inline Variable Angle

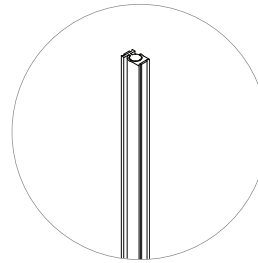

F W C A Glass Connector Kit – Corner Aluminum Square

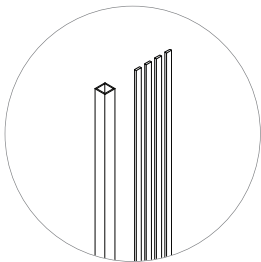

F W C N 90° Glass Connector Kit

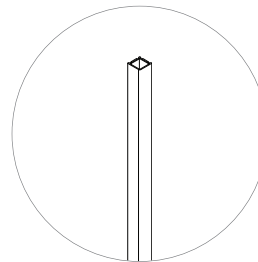

F W C T Three-Way Glass Connector Kit

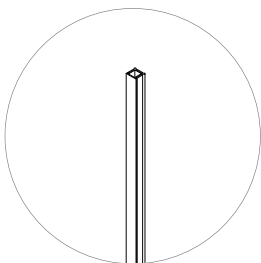

F W A K Activator Kit

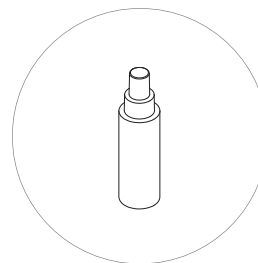

accessories & electrics

F W L S Leveling Shim Kit

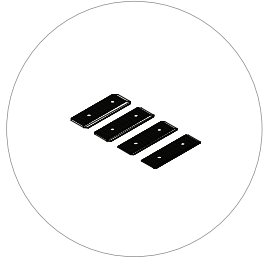

F W R S Door Stop

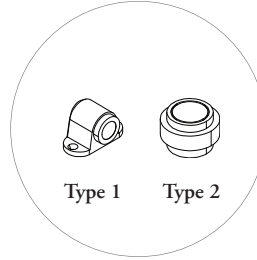

20

F W S F Safety Corner

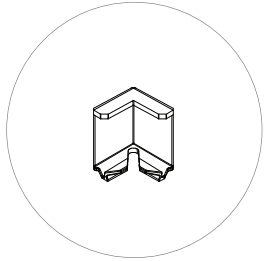

F W S K Splice Kit

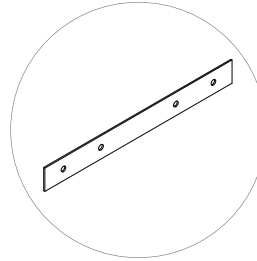

F W C K Ceiling Clip

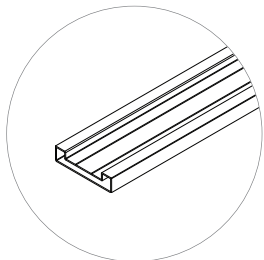

F W L M Light Module

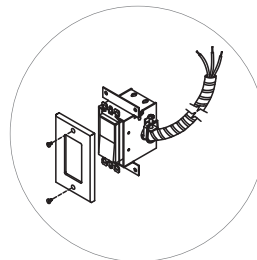

F W R M Receptacle Module

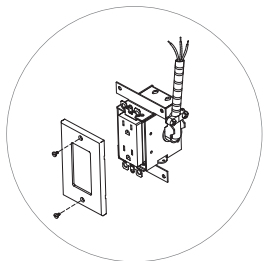

what is focus?

what is focus?

WHAT IS FOCUS?	24
PLANNING CONSIDERATIONS	26
PLANNING POSSIBILITIES	33

what is focus?

what is focus?

Focus is a demountable wall system that seamlessly integrates a variety of glass and solid fascias to create an array of modern, architecturally refined enclosures.

The system can be tailored to specific site conditions and acoustic requirements through a comprehensive glass wall and door pairing program. All pairings maintain visual and acoustic continuity throughout the wall run.

24

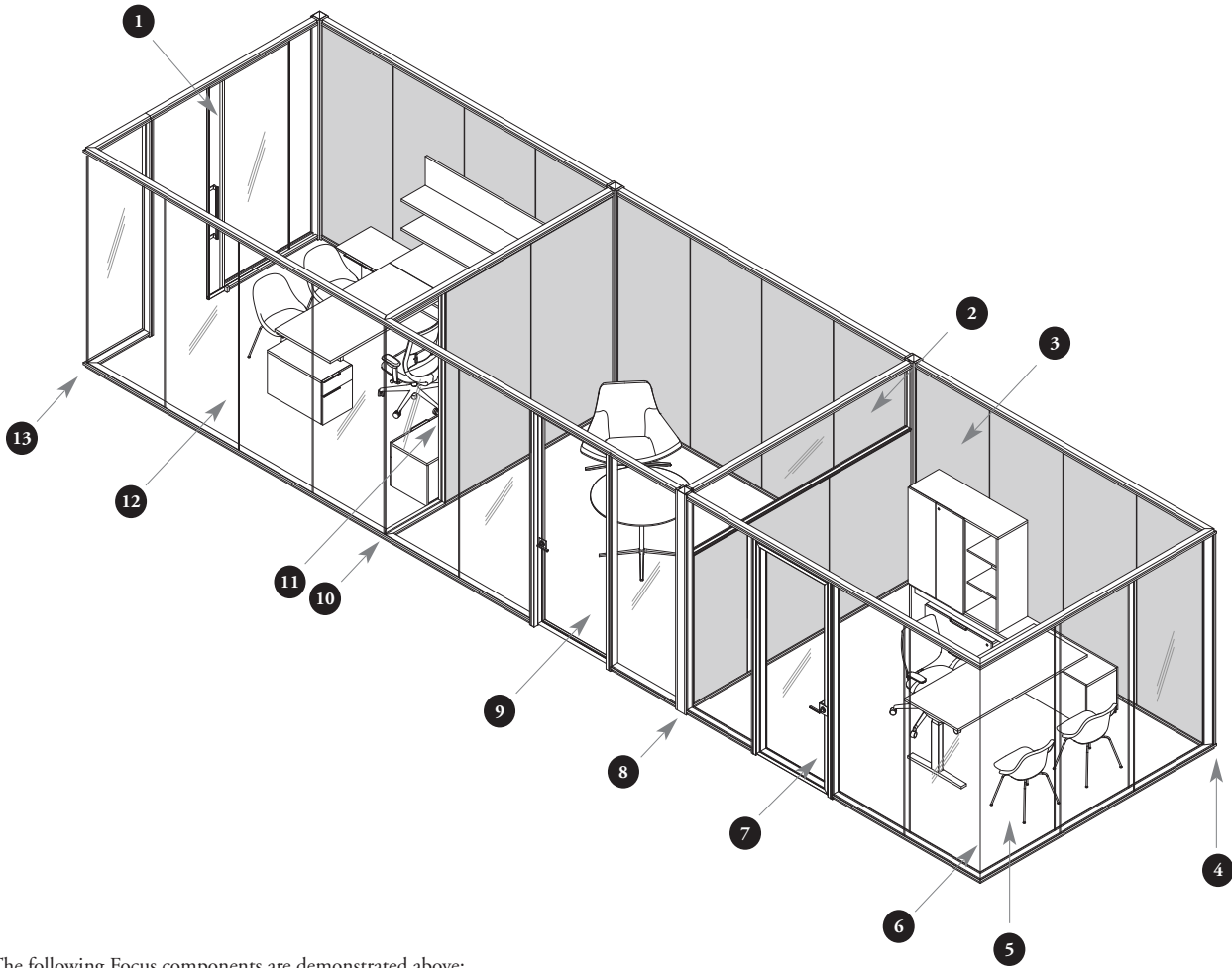

The following Focus components are demonstrated above:

- 1 Single Glazed Sliding Door
- 2 Clerestory with Double Glass Fascia
- 3 Solid Monolithic Demising Wall
- 4 Corner Double Glass to Solid Connection
- 5 Double Glass Fascia
- 6 90° Glass Corner Connector Kit (Double Glass)
- 7 Double Glazed Pivot Door
- 8 Corner Transition
- 9 Single Glazed Pivot Door
- 10 Three-Way Corner – Offset Glass
- 11 Inline Transition Connection – Solid to Single Center Glass
- 12 Offset Single Glass Fascia
- 13 90° Glass Connector Kit (Single Glass)

what is focus? (continued)

Focus offers a variety of unique planning features.

A continuous horizontal frame for inline solid to glass connections.

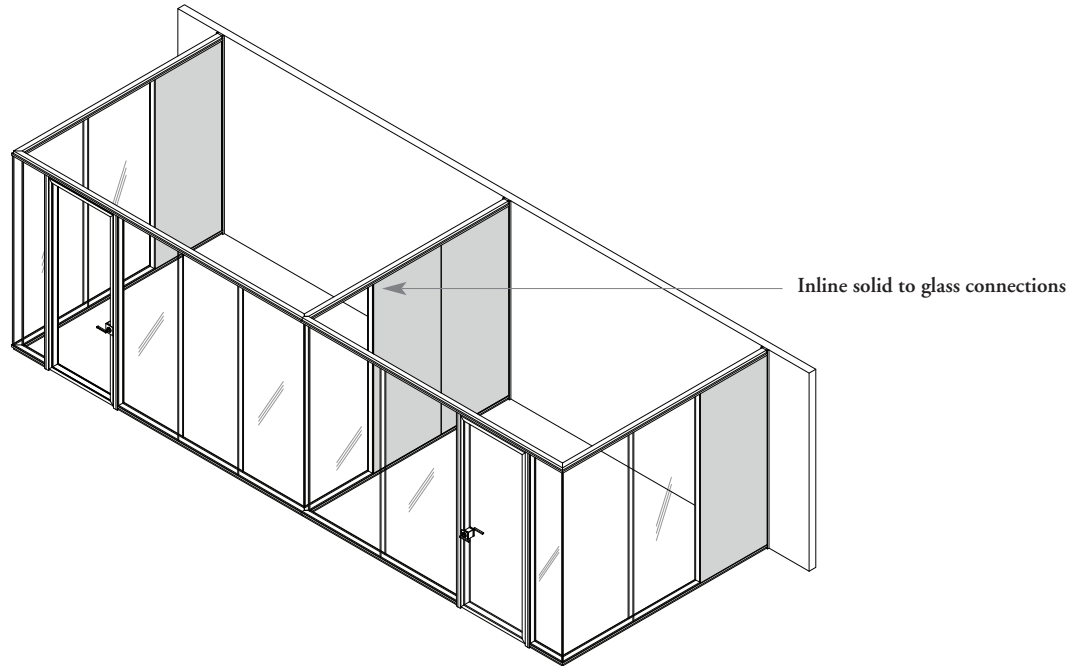

Glass clerestory configurations on demising walls.

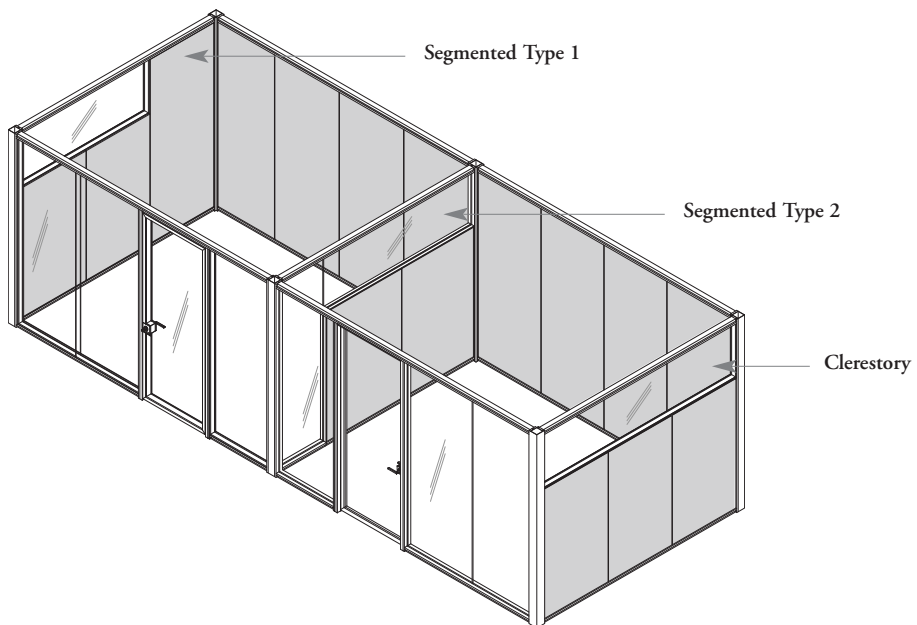

planning considerations

When specifying Focus, the following site condition steps and rules must be followed.

step 1: determine the site condition

Scenario A. Pre-constructed Site

- A. If the site has not yet been constructed Steps 6-8 must be followed prior to specification
- B. Establish desired nominal floor to ceiling height
- C. The General Contractor must hold the nominal floor to ceiling height within $\pm 1/8"$ over 10' (in the event of a drop ceiling, clips and blocks are possible but must be reviewed with Teknion)
- D. The General Contractor must hold the building architecture within $\pm 1/4"$ over length of wall span (tighter tolerances may be required when adjustable wall start applications are not used)
- E. Once the site is constructed, the nominal floor to ceiling height must be validated prior to installation

Scenario B. Constructed Site

- A. If the site is already constructed Steps 2-8 must be followed prior to specification

step 2: survey and measure the building site

- A. Use a laser to shoot the entire site to find the high and low spots in the finished floor and ceiling. Finished floor to ceiling measurements should be recorded every 12" along each linear span of Focus

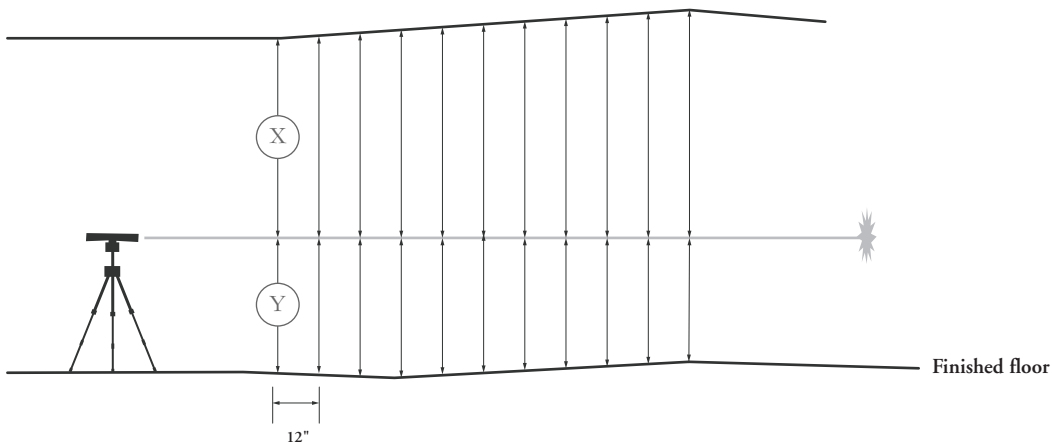

- B. Consider the location of HVAC and lighting panels on the ceiling before laying out wall runs. Focus should be planned to optimize the amount of natural light that will flow into corridors for energy savings and LEED credits

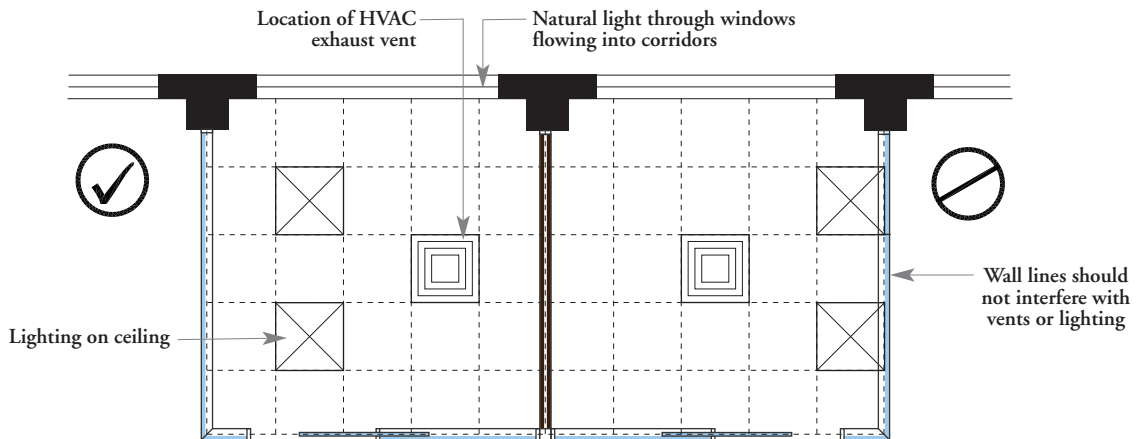

planning considerations (continued)

step 3: evaluate floor to ceiling deviations

Consider the leveling range of Focus and the nominal floor to ceiling height:

- The finished floor to ceiling height **cannot** expand more than 19mm over 10' in one wall run (+8mm in ceiling, + 11mm in floor)
- The finished floor to ceiling height **cannot** contract more than 11mm over 10' in one wall run (-7mm in ceiling, - 4mm in floor)

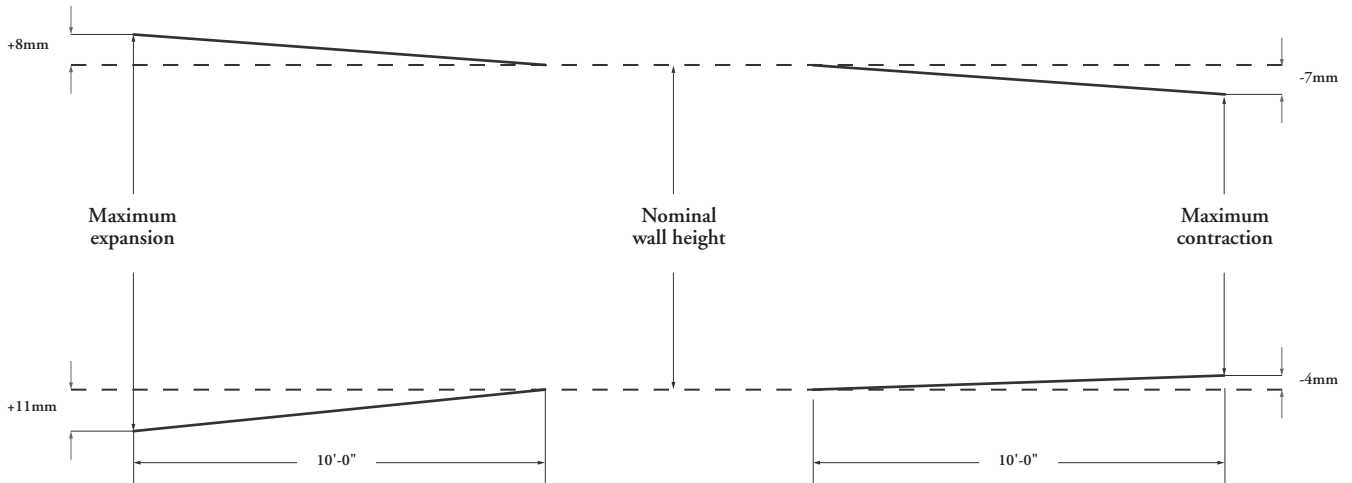

If the floor to ceiling deviations have exceeded these limits a wall end, wall start or vertical inline transition must be specified to reset nominal leveling. The following describes how to plan wall runs between verticals to allow for height transitions:

Gradual slope

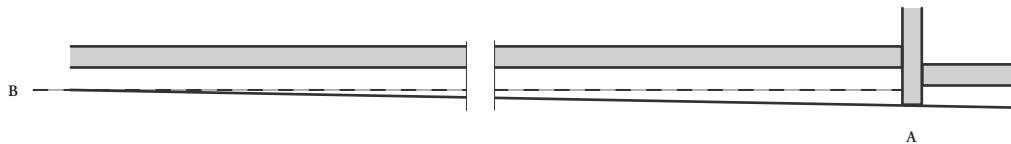

Valley

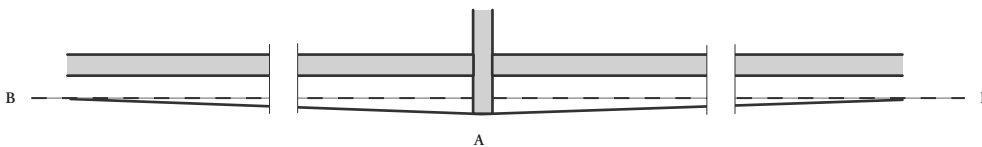

Hill

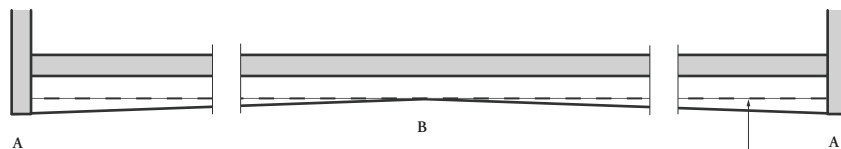

Legend summary

- A: Nominal leveling reset
- B: Nominal set point

Compressible shim required on either end

planning considerations (continued)

step 4: plan nominal heights with pivot and hinged doors

Pivot and hinge door frames are considered to be part of the wall run. The minimum floor to ceiling height within the door frame or swing area determines the nominal door and wall height of the run. On-site measurements should be checked against existing drawings prior to installation.

28

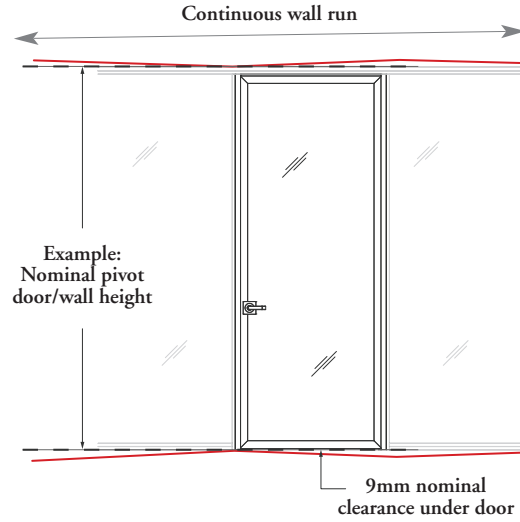
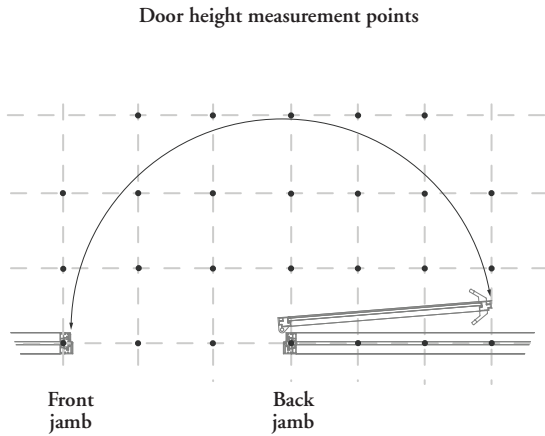

The following describes how to plan wall runs with pivot or hinged doors based on leveling limitations:

Scenario A:

Door and wall within leveling limits

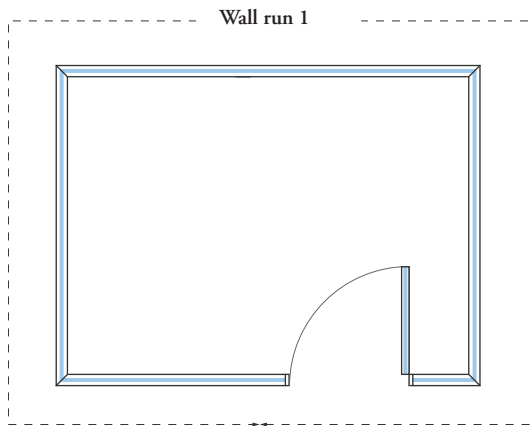

A. Run can be joined

Scenario B:

Door and wall leveling limits exceeded

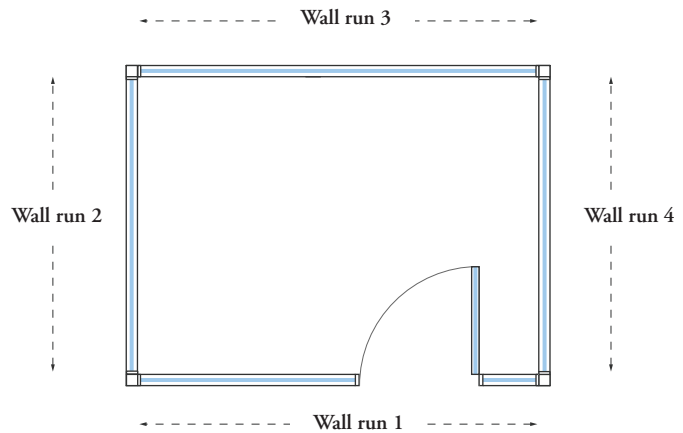

B. Runs are separated with wall ends to reset nominal leveling (other reset options can include wall starts and inline glass transitions)

planning considerations (continued)

step 5: plan nominal heights with sliding doors

Sliding door frames are considered to be part of the wall run. The minimum floor to ceiling height within the door frame determines the nominal door and wall height of the run. Measurements should be taken every 12" within the linear span of the door frame.

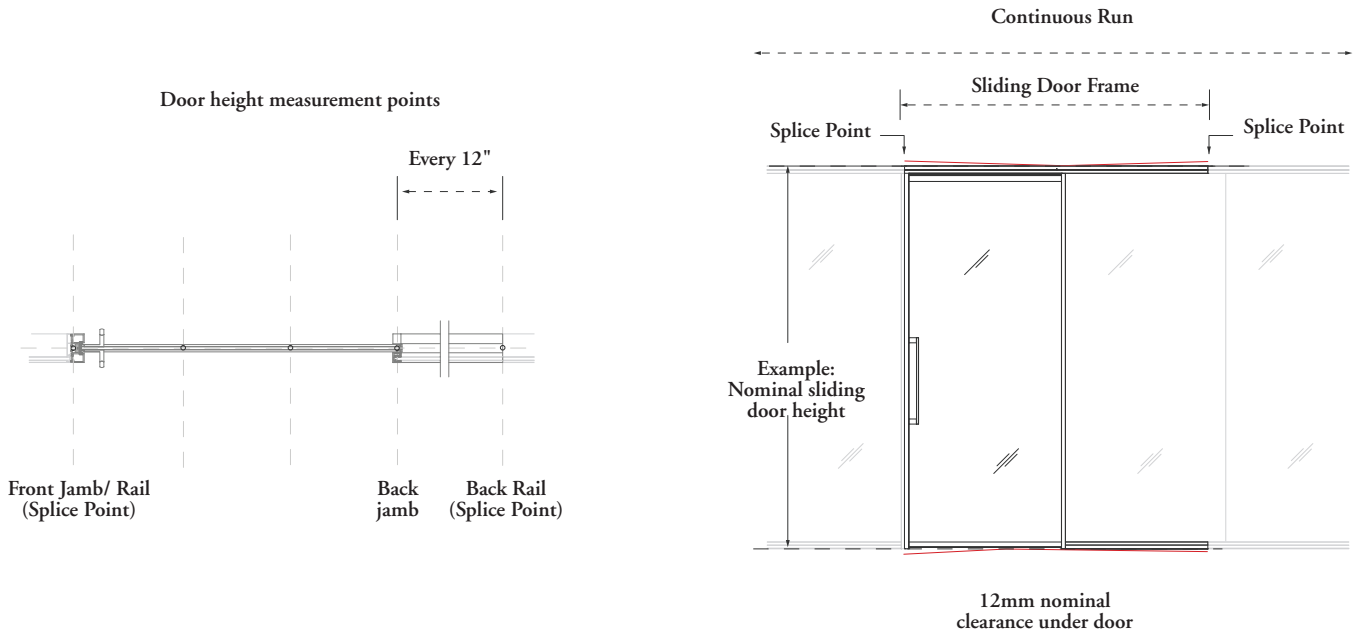

The following illustrations compare the profile elevation between a sliding door frame and a standard fascia frame. Both frames can be spliced together to create a continuous run without the need for a third post.

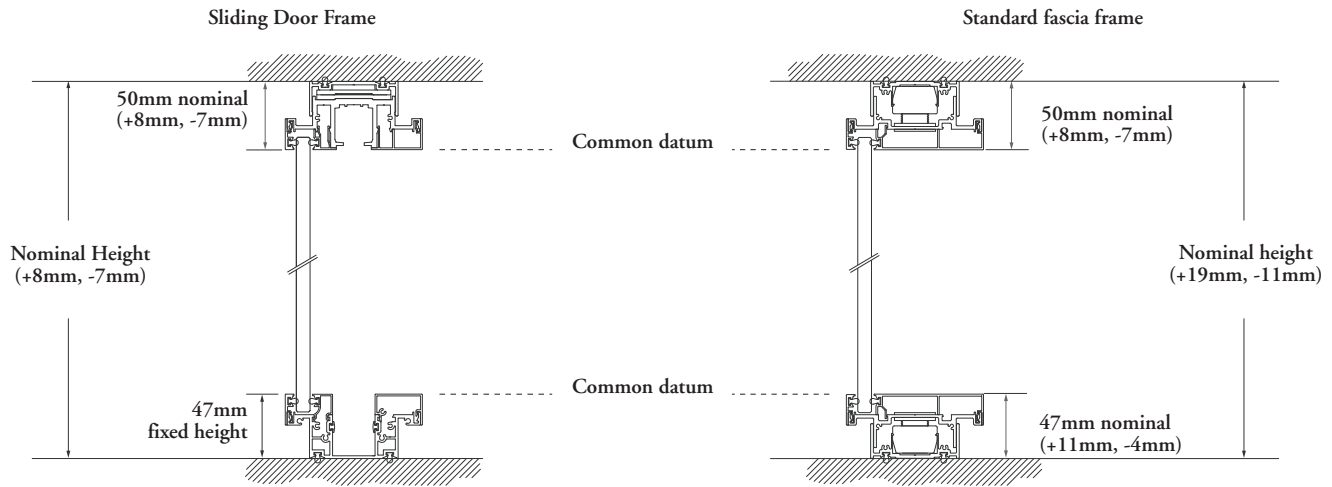

Refer to Focus Frame Leveling page for more information.

planning considerations (continued)

step 6: plan wall runs

Focus allows for three distinct types of runs:

- Runs that start
- Runs that end
- Runs that join

These runs can be combined to create the following conditions and tolerances:

Legend Summary

- A - Adjustable wall start
- B - Building and/or install requirement
- C - Cut from factory (1/16" increments)

Adjustable wall run conditions

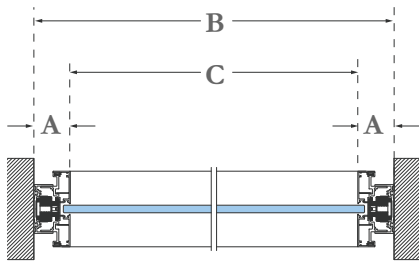

Start to start
A: 50mm nominal
B: Site hold to
C: Fixed

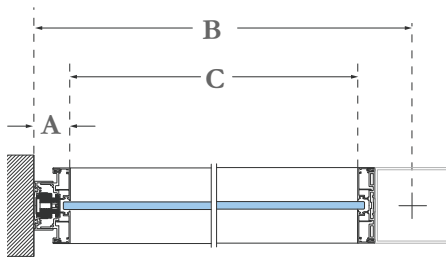

Start to end
A: 50mm nominal
B: Site hold to
C: Fixed

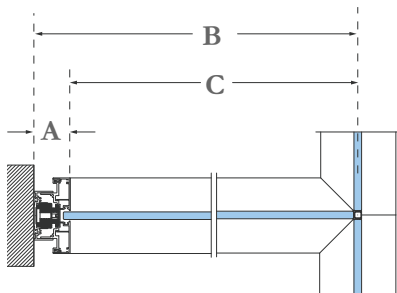

Start to join
A: 50mm nominal
B: Site hold to
C: Fixed

Fixed wall run conditions

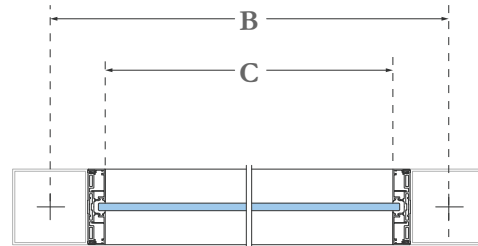

End to end
B/C: Fixed

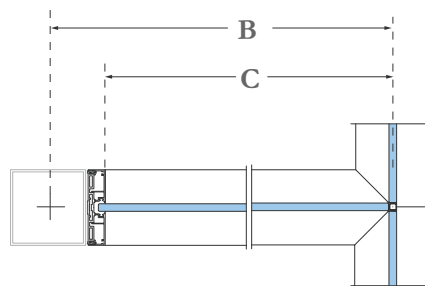

End to join
B/C: Fixed

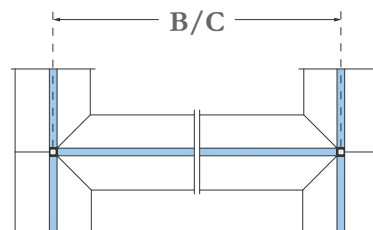

Join to join
B/C: Fixed

planning considerations (continued)

step 7: plan to accommodate existing building architecture

The following demonstrates adjustable and fixed wall conditions.

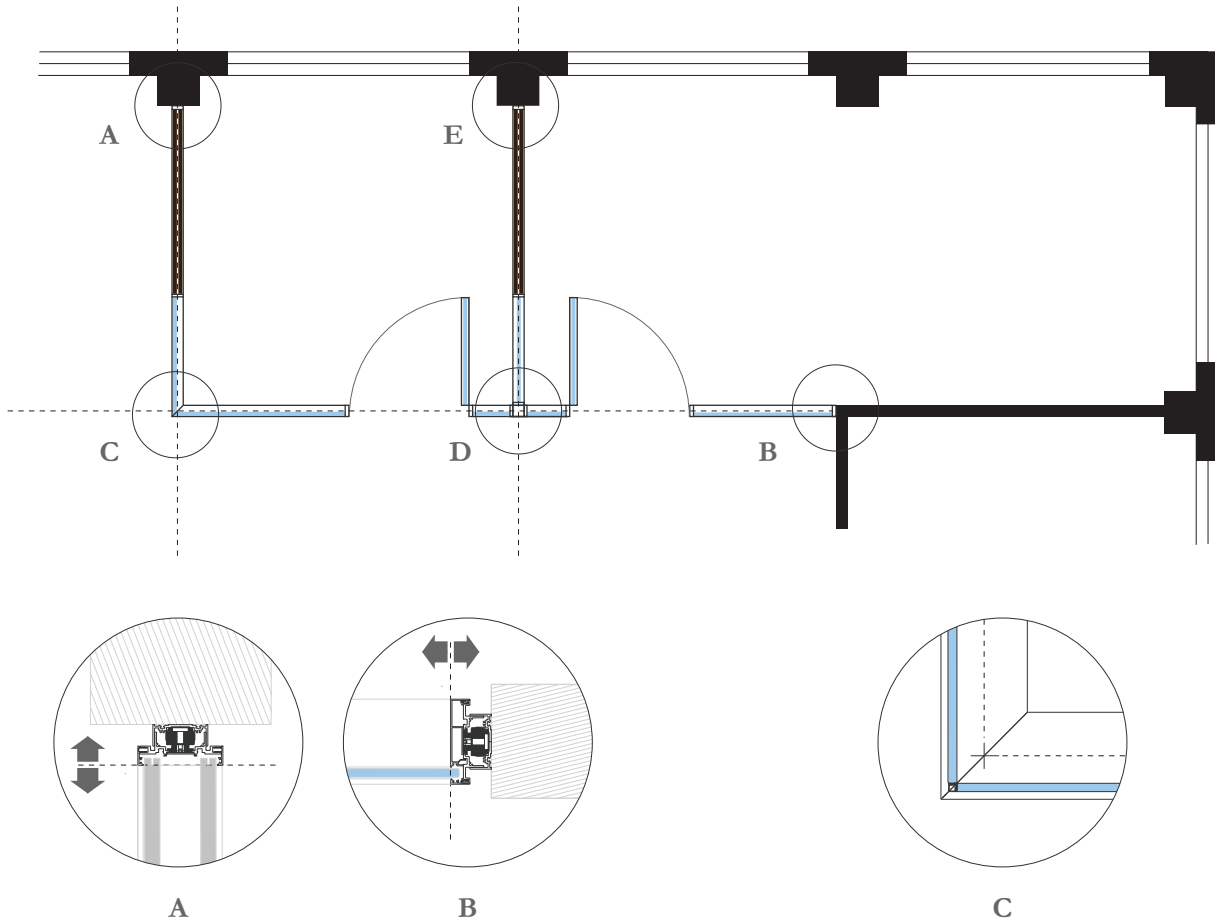

Use wall starts when connecting to building architecture to allow for on-site adjustability.

Join conditions are considered fixed datum points during installation.

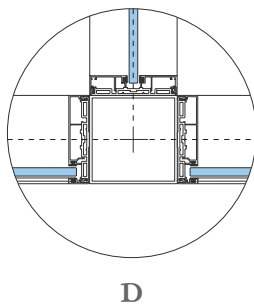

Wall end conditions are considered fixed datum points during installation.

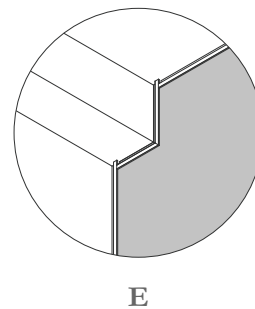

Wall starts and solid fascias can be modified on-site to accommodate bulkheads and irregular building walls.

planning considerations (continued)

step 8: consider wall and door acoustic pairing

Ensure that the wall and door specification for each room is logical from an acoustical perspective to ensure optimal performance. The chart below illustrates a basic guideline for door to wall acoustic alignment:

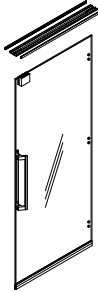
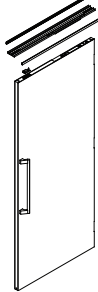
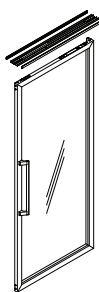
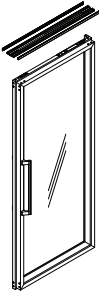
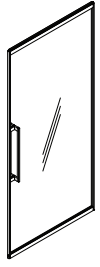
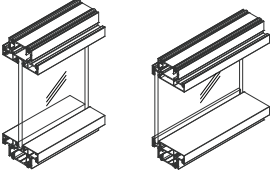
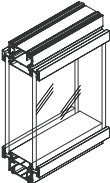
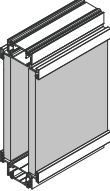
					
	Glass Hinged Door (FWHDS)	Solid Hinged Door (FWSDS)	Single Glazed Pivot Door (FWPDS) and Single Glazed Pivot Door - Double (FWPDD)	Double Glazed Pivot Door (FWDDS)	Single Glazed Sliding Door - Infinite Frame (FWBDSI)
 Center and offset glass	✓		✓		✓
 Double glass		✓		✓	
 Solid		✓		✓	

Please note any door can be joined to any wall if desired, but may **not** be an ideal acoustic solution.

planning possibilities

The following demonstrates the variety of planning possibilities available with Focus.

Throughout this guide the following materials will be represented as shown in this legend;

Legend Summary			
	Glass plan view		Drywall plan view
	Solid plan view		Drywall section

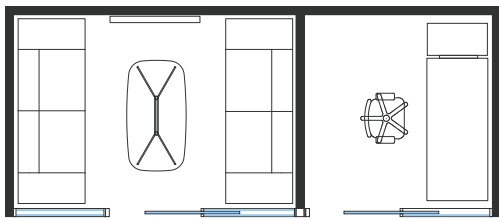

Enclaves (with drywall)

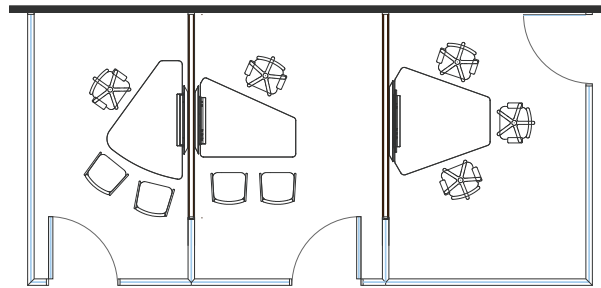

Store front (with drywall spine)

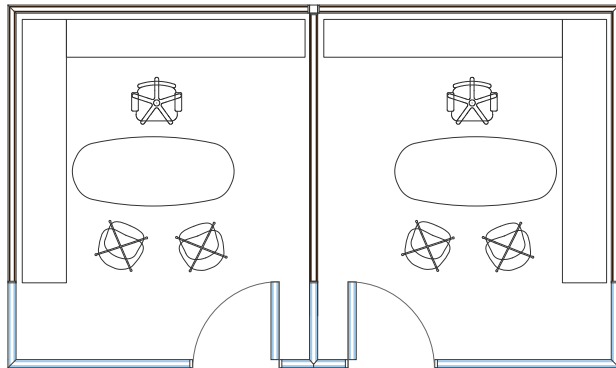

Private office cluster

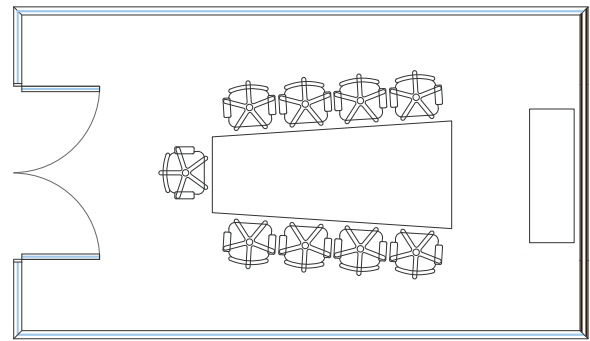

Boardroom

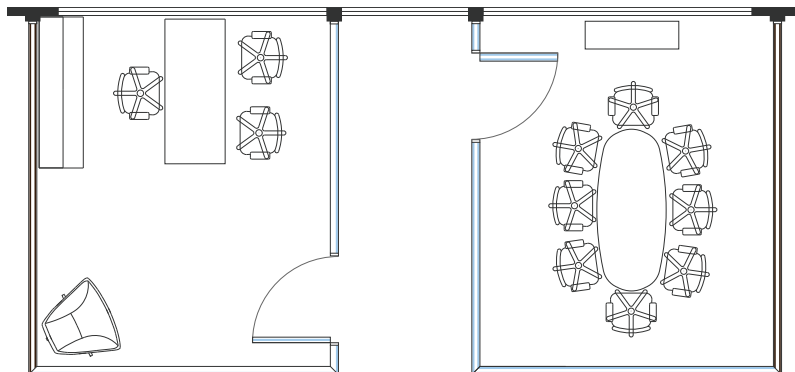



Building integration

planning possibilities (continued)

enclaves (with drywall)

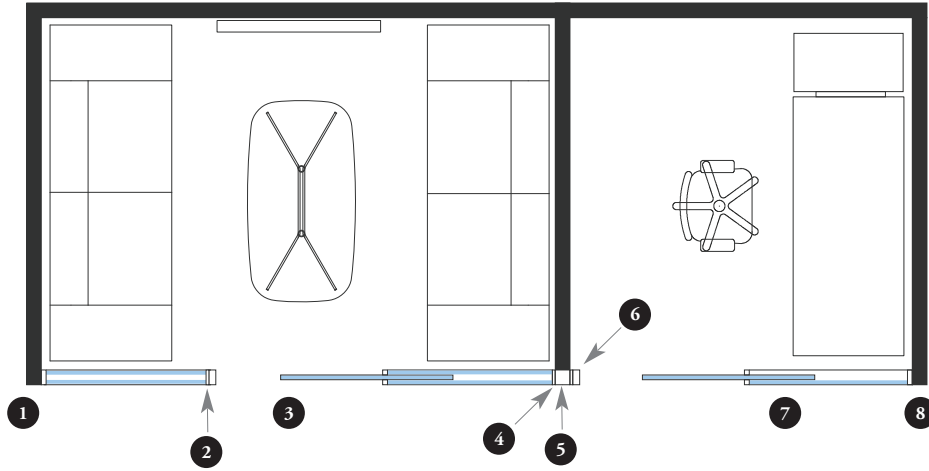
Glass walls and doors along the front of drywall enclosures provide light and visibility. Sliding doors are ideal in small spaces where a door swing is impractical.

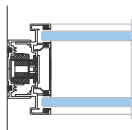
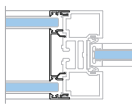
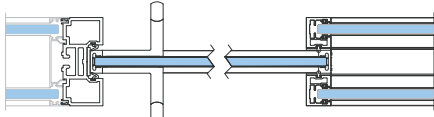
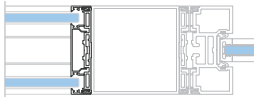

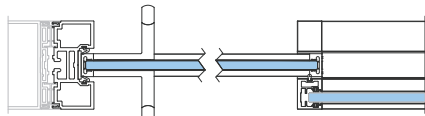
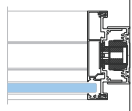
-  **1** Wall Start Double Glass (FWWGD)
-  **2** Wall Door Start Double Glass (FWWDGD)
-  **3** Double Glazed Sliding Door Infinite Frame – Single (FWDBIF)
Single Glazed Sliding Door – Infinite Frame (FWBDSI)
-  **4** Wall End Inline Double Glass (FWWD)
-  **5** Corner Transition (FWTCD)
-  **6** Wall End Inline Door (FWTID)
-  **7** Single Glazed Sliding Door Infinite Frame – Single (FWSBIF)
Single Glazed Sliding Door – Infinite Frame (FWBDSI)
-  **8** Wall Start Single Offset Glass (FWWGO)

planning possibilities (continued)

storefront (with drywall spine and altos demising walls)

Store fronts are continuous runs of glass that run along the perimeter of a space. The following demonstrates a continuous run of single center glass in a storefront application. Seamless three-way glass corners transition to Altos (Portrait and Landscape) solid demising walls for furniture integration possibilities. Tek Pier is only possible with Altos portrait.

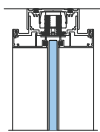
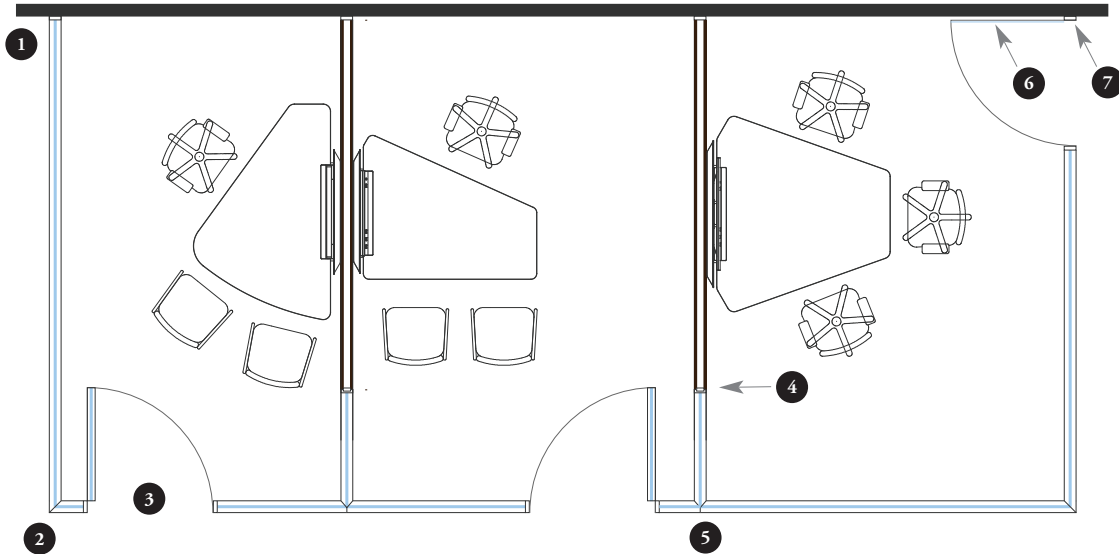

1 Wall Start Single Centered Glass (FWWGS)

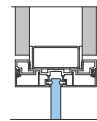

4 Transition Inline Connection Focus to Altos - Centered Glass Option (FWTIFA)

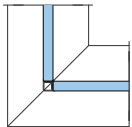

2 90° Glass Connector Kit (FWCN)

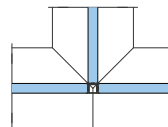

5 90° Glass Connection Kit (FWCN)

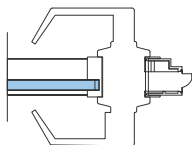

3 Single Glazed Pivot Door (FWPDS)

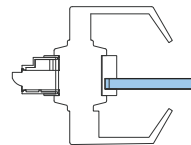

6 Glass Hinged Door (FWHDS)



7 Wall Start Door (FWWHD)

planning possibilities (continued)

private office cluster

High acoustic solutions can be achieved within an open plan environment through the use of solid, double glass walls and pivot doors.

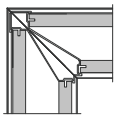
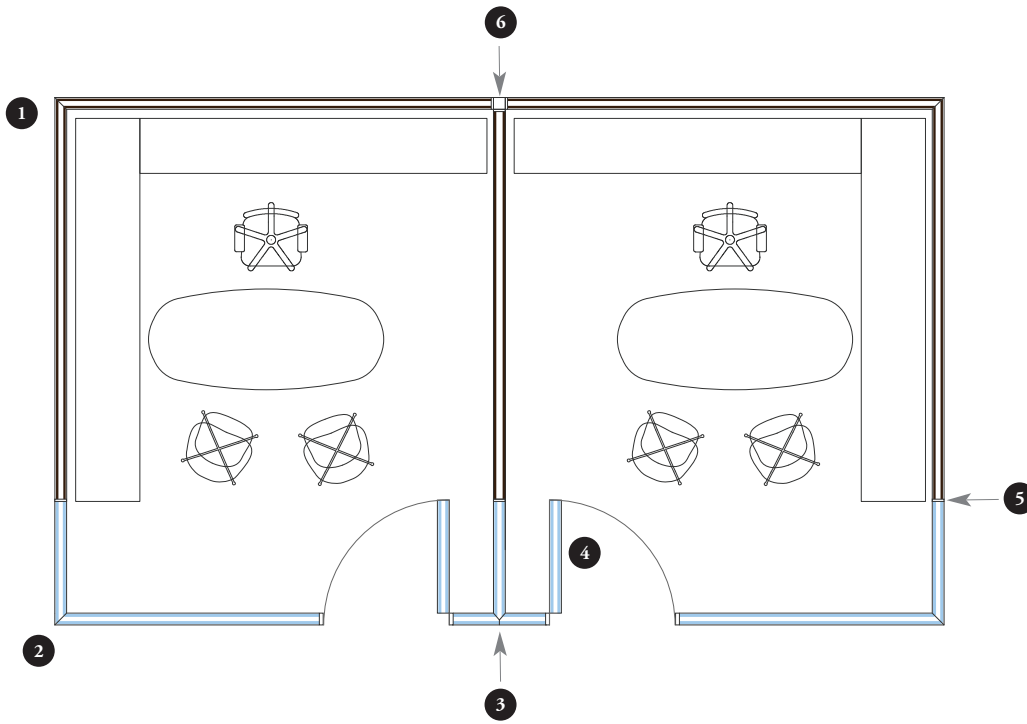

1 Corner Double Glass or Solid to Solid Connection (FWTDS)

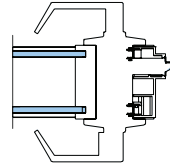

4 Double Glazed Pivot Door (FWDDS)

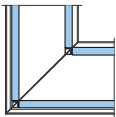

2 90° Glass Connector Kit (FWCN)

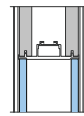

5 Inline Transition Connection – Solid to Double Glass (FWTISGD)

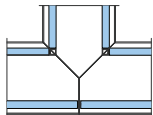

3 Two 90° Glass Connection Kits (FWCN) and one Glass Connector Kit – Inline Clear Plastic (FWIP)

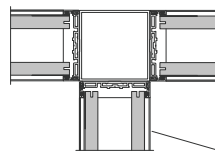

6 Corner Transition (FWTCD) and Wall End Inline Solid (FWWS)

Clerestory (solid to double glass)

planning possibilities (continued)

boardroom

Open plan boardrooms with double leaf pivot doors allow for high traffic flow. Glass and solid walls can transition directly at a corner.

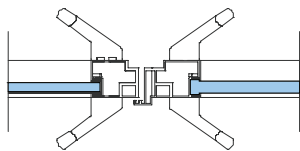
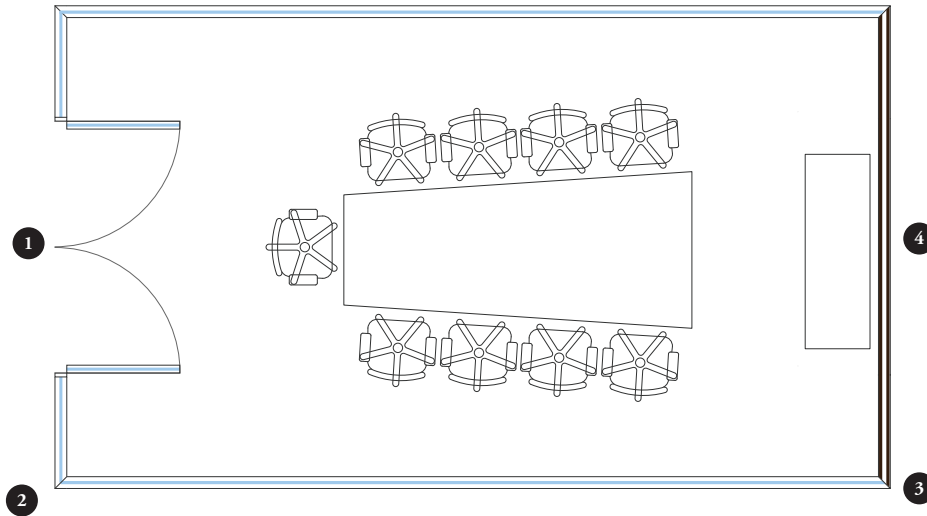

1 Single Glazed Pivot Door – Double (FWPDD) and Single Glazed Pivot Door Double Frame (FWPSDF)

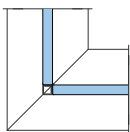

2 90° Glass Connector Kit (FWCN)

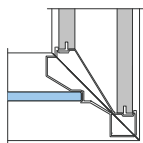

3 Corner Double Glass or Solid to Single Centered Glass Connection (FWTDGS)

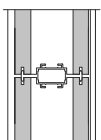

4 Inline Transition Connection – Solid to Solid (FWITSS)

planning possibilities (continued)

building integration

Walls can be planned to reference building architecture. Each room is fine tuned to have a specific acoustic performance while maintaining the same visual aesthetic from the exterior view.

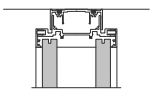
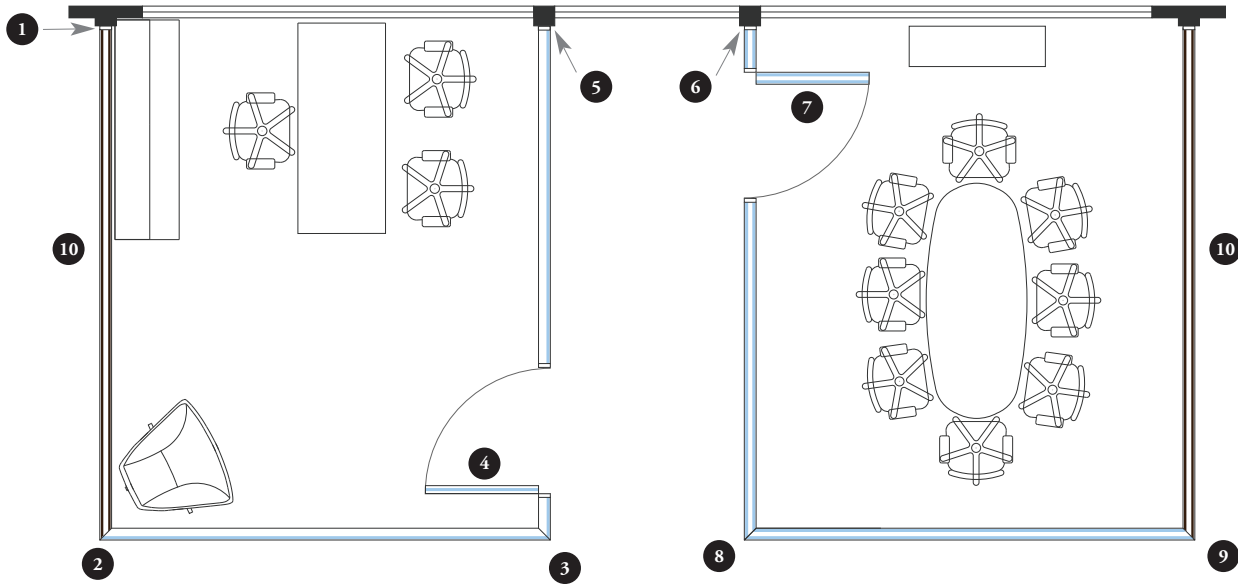

1 Wall Start Solid (FWWSD)

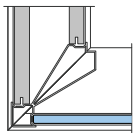

2 Corner Double Glass or Solid to Single Offset Glass Connection (FWTDGO)

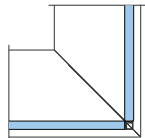

3 90° Glass Connector Kit (FVCN)

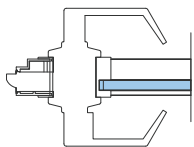

4 Single Glazed Pivot Door (FWPDS)

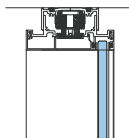

5 Wall Start Single Offset Glass (FWWGO)

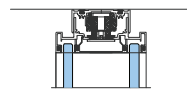

6 Wall Start Double Glass (FWWGD)

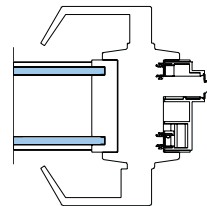

7 Double Glazed Pivot Door (FWDDS)

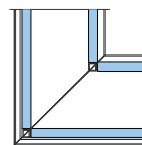

8 90° Glass Connector Kit (FVCN)

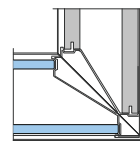

9 Corner Double Glass or Solid to Solid Connection (FWTDS)

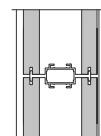

10 Inline Transition Connection – Solid to Solid (FWITSS)

frames & trims

frames & trims

UNDERSTANDING HORIZONTAL FRAME ASSEMBLIES	42
SINGLE FRAME ASSEMBLY BASICS	43
DOUBLE & SOLID FRAME ASSEMBLY BASICS	44
HORIZONTAL EXTRUSION TRIM BASICS	45
PLANNING WITH HORIZONTAL FRAME ASSEMBLIES	46

understanding horizontal frame assemblies

Focus frames consist of ceiling, base and vertical frames and are available to accommodate 10mm and 12mm glass and solid fascias.

The following outlines the components of the ceiling and base assemblies.

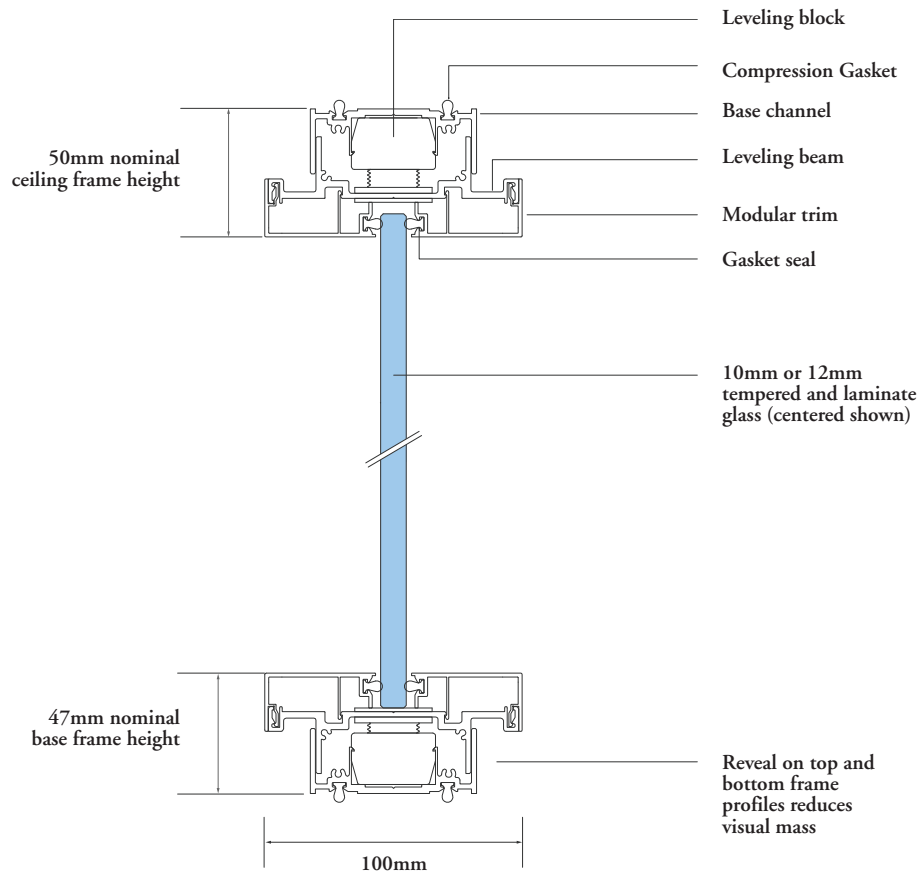

A variety of glass and solid fascia mounting options are available with horizontal frames.

Inline (shown)

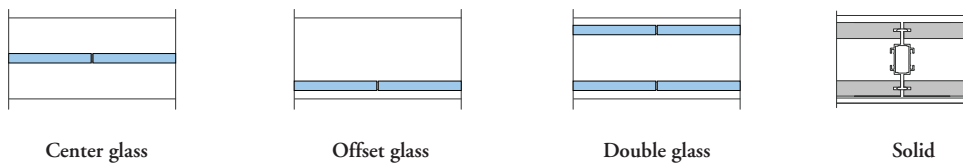

single frame assembly basics

Single frame assemblies allow for a single 10mm or 12mm glass fascia to be mounted in the center or offset location of a frame.

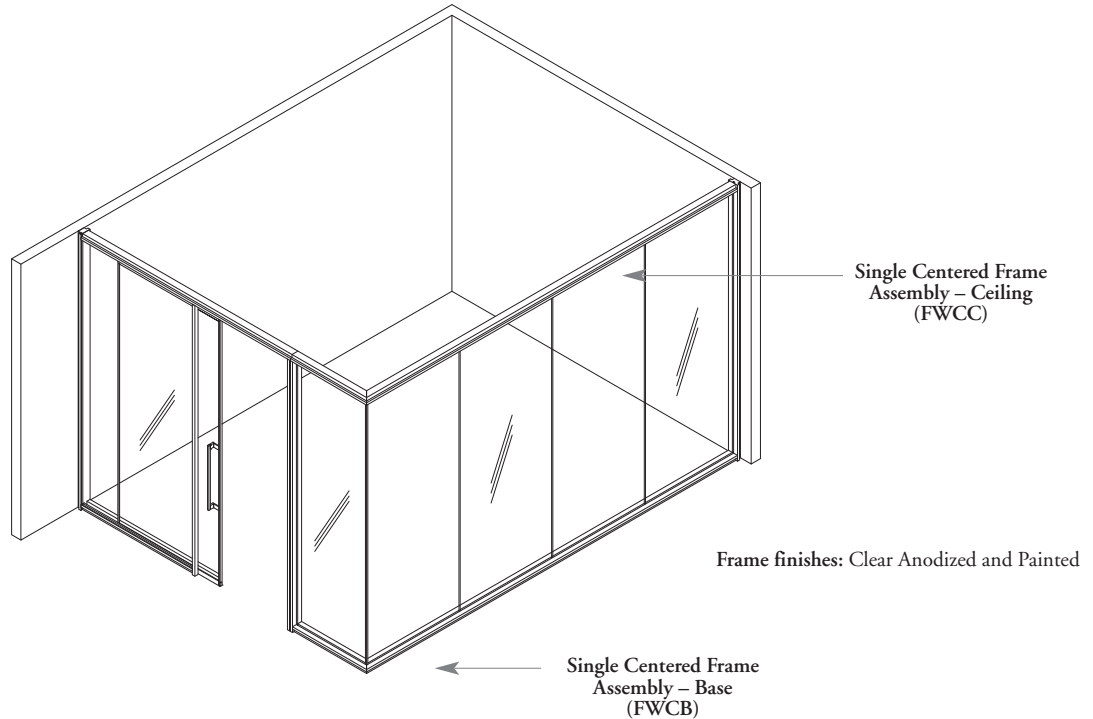

- Extrusions are available in nominal widths from 12" to 120" with the ability to specify to 1/16" increments
- Extrusions are available in three conditions
 - Angled
 - Three-way mitred
 - Four-way mitred
- When specifying extrusions a left and right angled increment must be selected
- The increments represent the two extrusion angles (when viewed from the exterior) required to make up the overall planning angle required

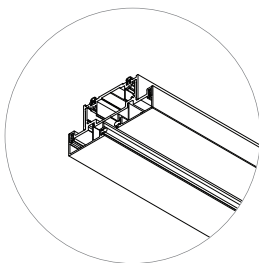

Single Centered Frame Assembly – Ceiling (FWCC)

- Adjustable ceiling frame for single centered glass fascias

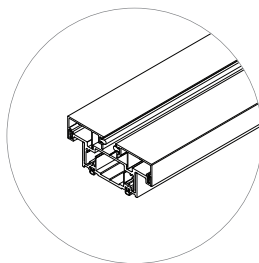

Single Centered Frame Assembly – Base (FWCB)

- Adjustable base frame for single centered glass fascias
- Safety corners are used to soften corner edges, for more information see the Accessories & Electrical section

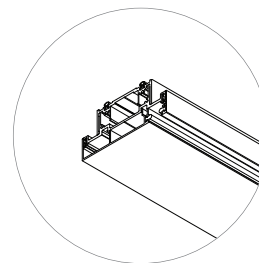

Single Offset Frame Assembly – Ceiling (FWOC)

- Adjustable ceiling frame for offset single centered glass fascias

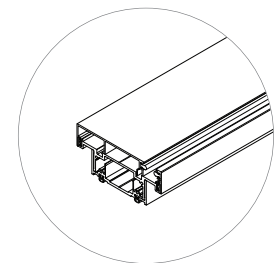

Single Offset Frame Assembly – Base (FWOB)

- Adjustable base frame for offset single centered glass fascias
- Safety corners are used to soften corner edges, for more information see the Accessories & Electrical section

double & solid frame assembly basics

Double and solid frame assemblies allow for double 10mm or 12mm glass or solid fascias to be mounted to the frame.

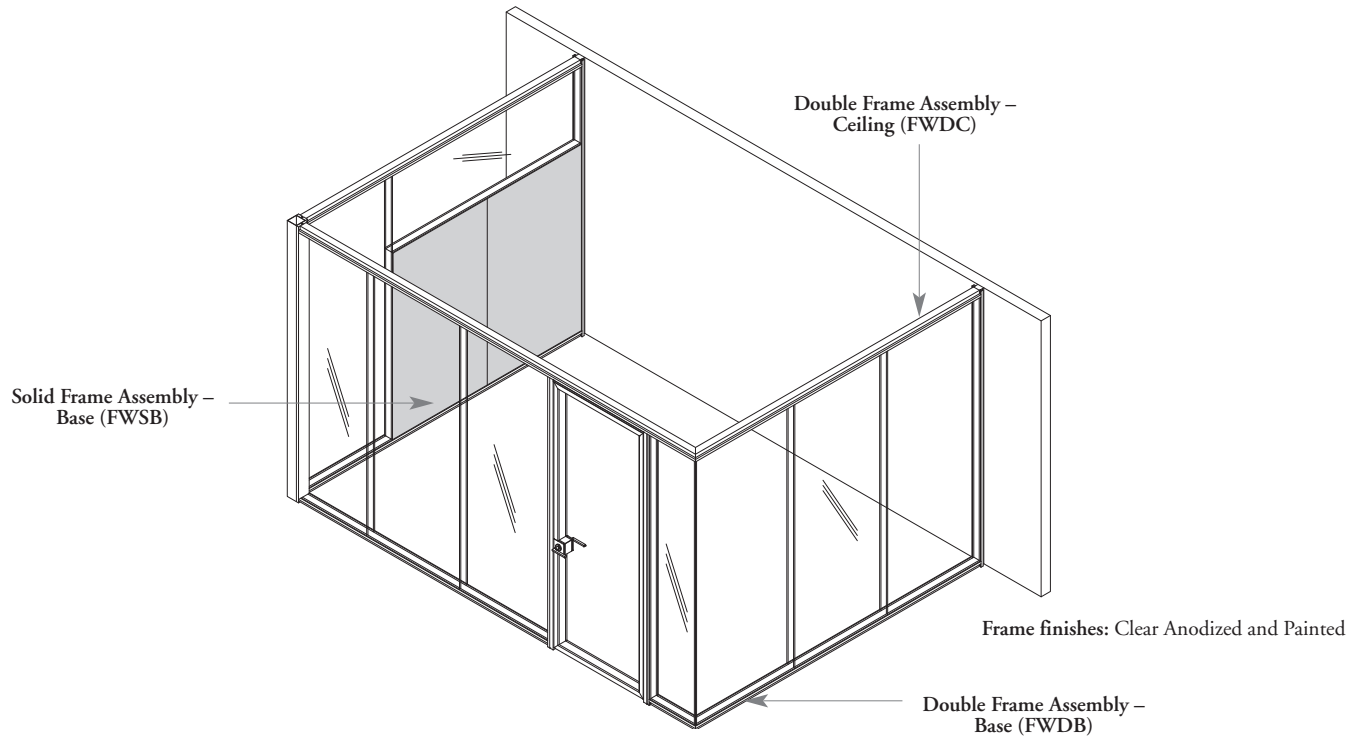

- Extrusions are available in nominal widths from 12" to 120" with the ability to specify to 1/16" increments
- Extrusions are available in three conditions
 - Angled
 - Three-way mitred
 - Four-way mitred
- When specifying extrusions a left and right angled increment must be selected
- The increments represent the two extrusion angles (when viewed from the exterior) required to make up the overall planning angle required

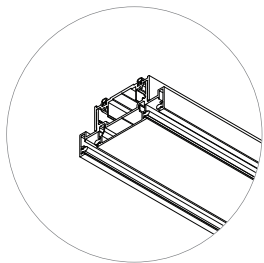

Double Frame Assembly – Ceiling (FWDC)

- Adjustable ceiling frame for double glass fascias

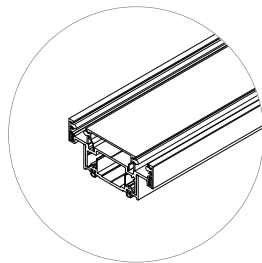

Double Frame Assembly – Base (FWDB)

- Adjustable base frame for double glass fascias
- Safety corners are used to soften corner edges, for more information see the Accessories & Electrical section

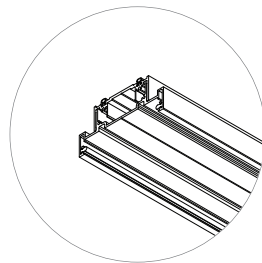

Solid Frame Assembly – Ceiling (FWSC)

- Adjustable ceiling frame for solid fascias

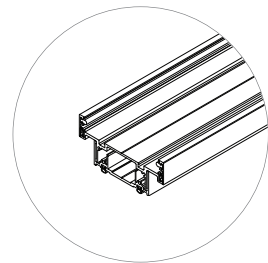

Solid Frame Assembly – Base (FWSB)

- Adjustable base frame for solid fascias
- Safety corners are used to soften corner edges, for more information see the Accessories & Electrical section

horizontal extrusion trim basics

The Focus horizontal trim provides a minimal horizontal trim that connects solid to glass fascias in clerestory applications.

For Clerestory planning information, please refer to the Clerestory section.

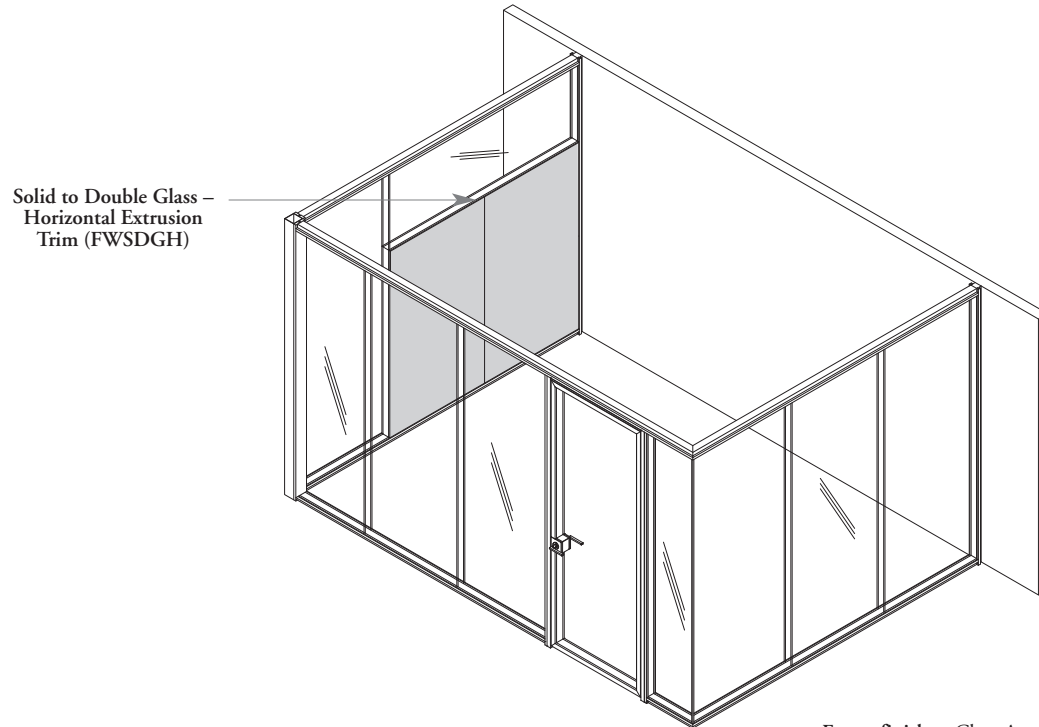

Frame finishes: Clear Anodized and Painted

- Extrusions are available in nominal widths from 12" to 120" with the ability to specify to 1/16" increments
- When specifying extrusions a left and right angled increment must be selected

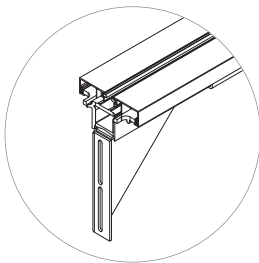

Solid to Single Glass – Horizontal Extrusion Trim (FWSSGH)

- Used between solid fascias and center glass clerestory

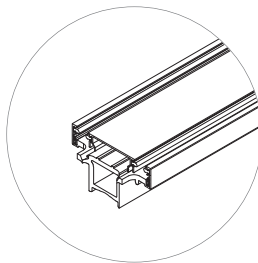

Solid to Double Glass – Horizontal Extrusion Trim (FWSDGH)

- Used between solid fascias and double glass clerestory

planning with horizontal frames

The following describes the floor to ceiling leveling accommodation provided by Focus horizontal frames.

- If the site is in a pre-constructed condition, the nominal floor to ceiling height can be specified. In this case the nominal floor to ceiling height must be kept within +/- 1/8" over 10'-0"
- If the site is in a constructed condition, the nominal floor to ceiling height is determined through site measurements and specification software
- Based on the nominal floor to ceiling height, base and ceiling frame have an overall leveling range of 30mm (+19mm / -11mm)
 - Ceiling frame has an overall levelling range of 15mm (+8mm / -7mm)
 - Base frame has an overall levelling range of 15mm (+11mm / -4mm)

46

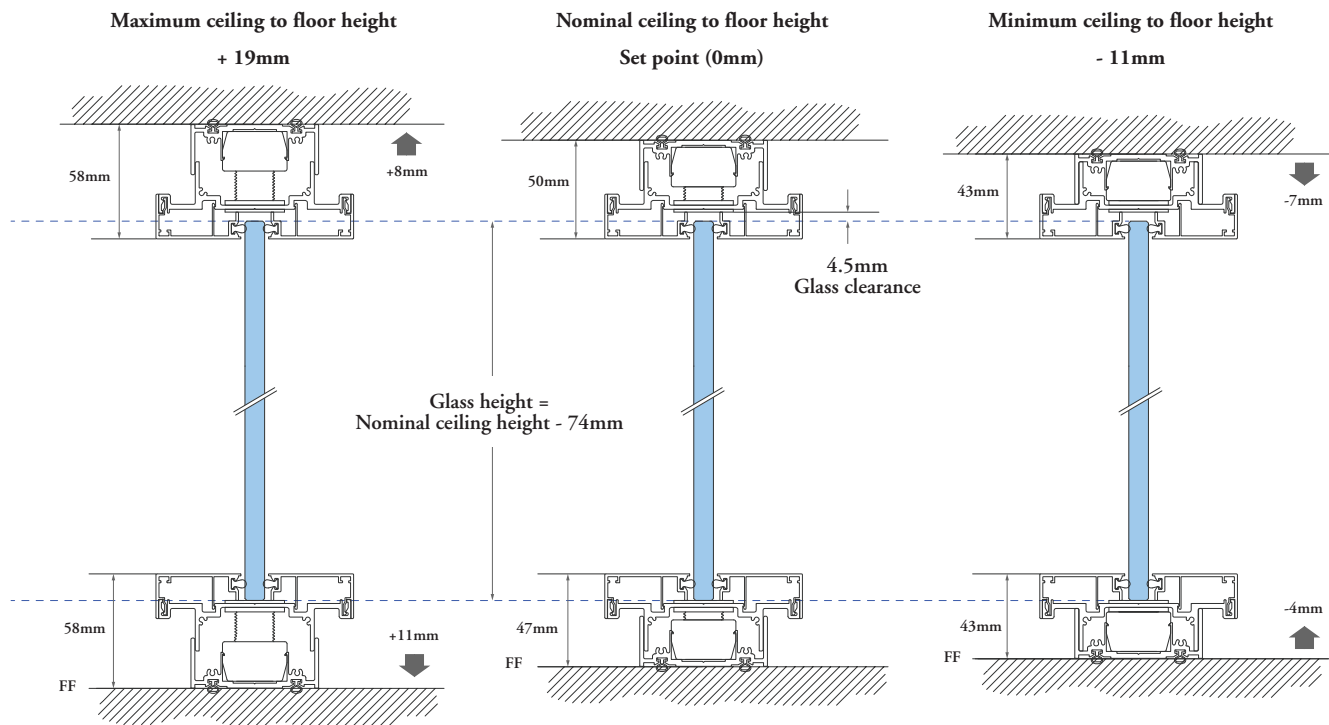

FF = Finished floor

planning with horizontal frames (continued)

The following describes how to specify cuts for horizontal frames. The cut angle and orientation is determined from the side designated as external. Cuts are specified independently on both sides of each frame assemblies.

Join Condition	Diagram	Cut Specification	Restrictions
Inline		A: Right Cut, Angled, 90° B: Left Cut, Angled, 90°	The frame cut must be on module with the fascias.
Two-way corner (90° Corner)		A: Right Cut, Angled, 135° B: Left Cut, Angled, 45°	The frame cut must be on module with the fascias.
Three-way corner (Centered)		A: Right Cut, Three Way, 135° B: Left Cut, Three Way, 45° C: Four Way, 0°	The frame cut must be on module with the fascias.
Three-way corner (Off-set)		A: Right Cut, Three Way 120° B: Left Cut, Three Way 60° C: Offset Mitred 0°	The frame cut must be on module with the fascias.
Four-way corner		A: Four Way, 0° B: Four Way, 0° C: Four Way, 0° D: Four Way, 0°	The frame cut must be on module with the fascias.
Variable angle		W = 110° - 170° (10° increments) A = Right Cut, Angled, [180°-(W+2)] B = Left Cut, Angled, [W+2]	The frame cut must be on module with the fascias.

fascias

fascias

UNDERSTANDING FASCIAS	51
SOLID & GLASS FASCIA BASICS	52
PLANNING WITH FASCIAS	53
PLANNING WITH GLASS FASCIAS	55
ELECTRICAL FILLER PANEL FASCIA BASICS	56
PLANNING WITH ELECTRICAL FILLER PANEL FASCIAS	57

understanding fascias

Focus fascias are available in glass, solid or with an electrical filler panel to provide varying levels of privacy and access to electrical.

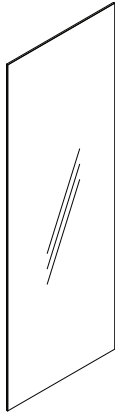

glass

Glass fascias are ideal when light transmission is required through adjacent rooms and building spaces.

Single or double glazing can be specified depending on the acoustic requirements of the space.

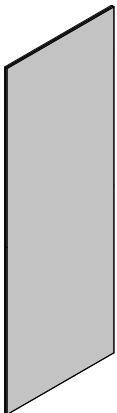

solid

Solid fascias allow for visual and acoustic privacy and can accommodate electrical receptacles.

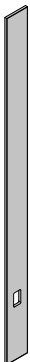

electrical filler panel

The Electrical Filler Panel Fascia is narrow in width and is typically used beside doors to house electrical receptacles and switches.

solid & glass fascia basics

Solid and glass fascias create the faces of Focus walls.

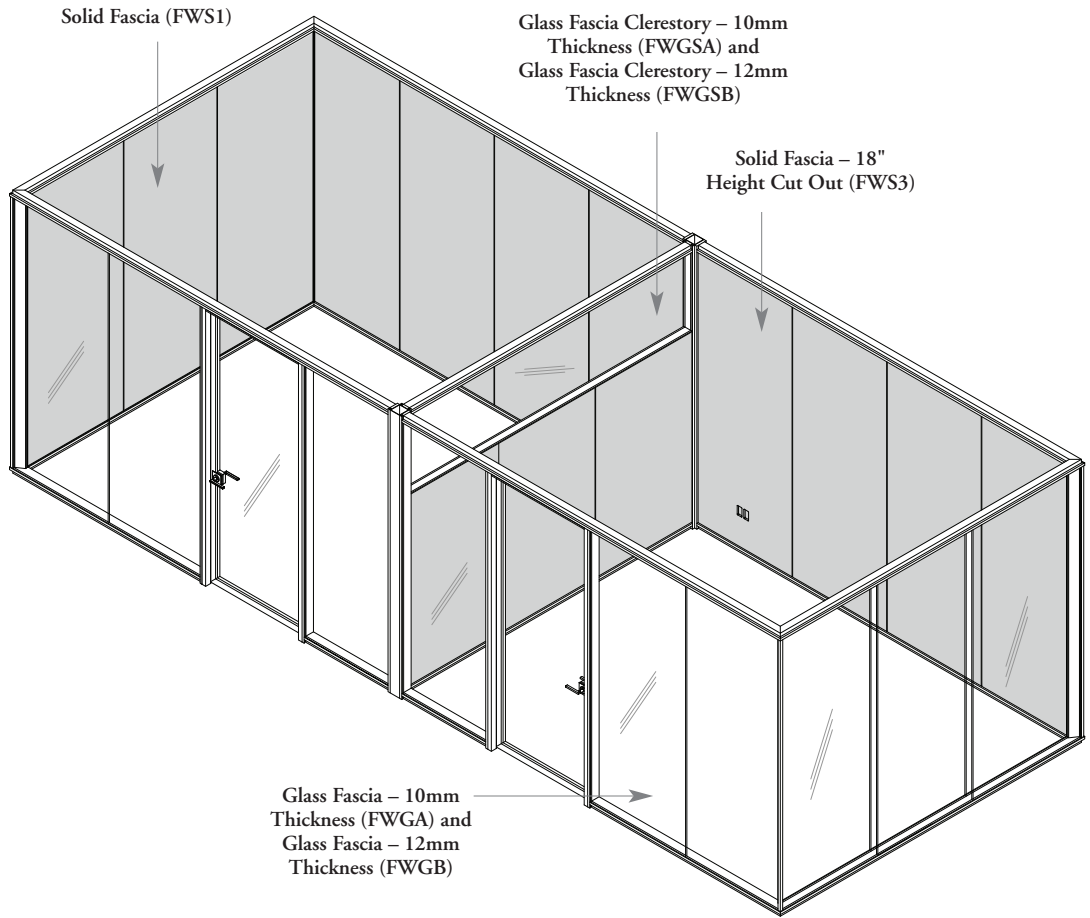

Glass finishes: Tempered, Laminated and Low Iron
 Solid fascia finishes: Laminate, Flintwood and Veneer

52



Glass Fascia – 10mm Thickness (FWGA) and Glass Fascia – 12mm Thickness (FWGB)

- Monolithic glass fascias
- Two glass edge styles are available
 - straight on both sides
 - mitered on one side and straight on the other



Solid Fascia (FWS1)
 • Monolithic solid fascia



Solid Fascia – 18" Height Cut Out (FWS3)
 • Monolithic solid fascia with electric module integration
 • Electrical cut outs are located 18" above the floor with one or two vertical cut outs

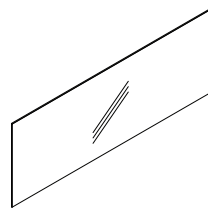

Glass Fascia Clerestory – 10mm Thickness (FWGSA) and Glass Fascia Clerestory – 12mm Thickness (FWGSB)

- Glass fascia for clerestory application
- For more information on clerestory applications, please see the Clerestory section

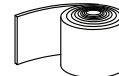

Insulation (FWI)
 • Used with solid fascias to provide additional acoustic privacy

planning with fascias

The following outlines the available sizes for focus fascias.

Fascia height and width sizes shown are nominal with the ability to specify to 1/16" increments.

glass fascias

Ceiling height:

84" - 111" for tempered 10mm

84" - 120" for tempered 12mm

84" - 120" for laminate 10mm and 12mm

Glass width:

12" - 36" for 10mm

12" - 48" for 12mm

Maximum run:

24" for 10mm

36" for 12mm

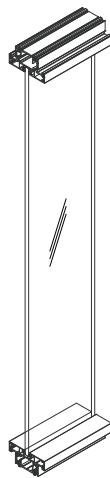

Center glass

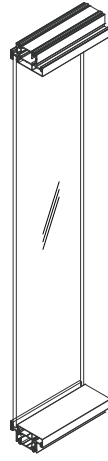

Offset glass

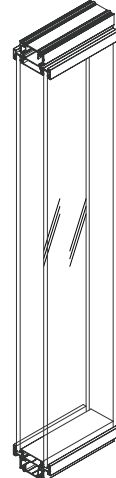

Double glass

solid fascias

Ceiling height: 84" - 120"

Fascia width: 12" - 48"

Maximum run width: 36"

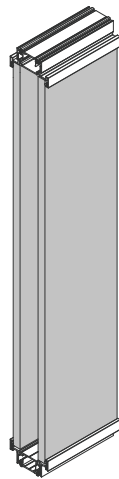

Solid

clerestory

Ceiling height: 96" - 120"

Minimum solid fascia height: 72"

Maximum run width: 117-1/4"

Glass width range:

12" - 118-1/16" for 10mm/12mm

Glass height range:

12" - 42" for 10mm

12" - 44-12/16" for 12mm

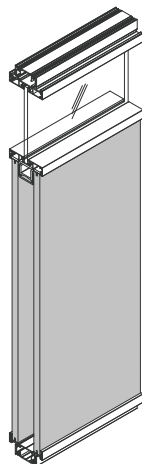

Solid to center glass

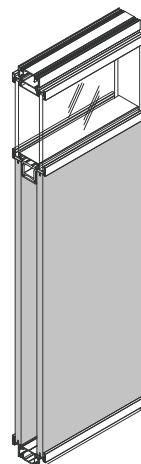

Solid to double glass

planning with fascias (continued)

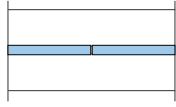
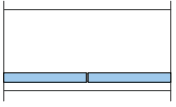
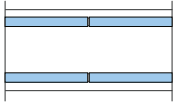
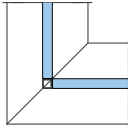
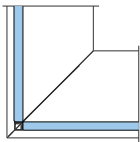
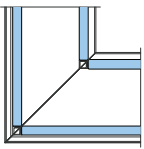
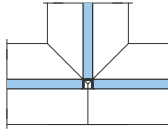
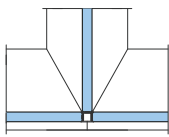
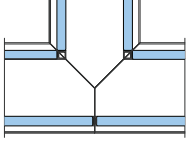
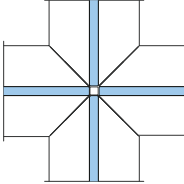
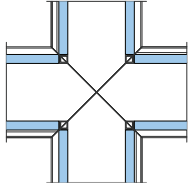
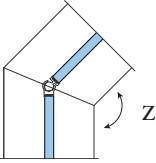
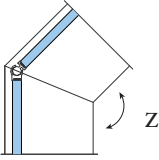
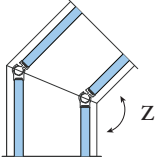

The following demonstrates the variety of glass fascias that are available.

54

	Center glass	Offset glass	Double glass
Inline			
Two-way corner (90° corner)			
Three-way corner			
Four-way corner			
Variable angle Z: 110-170° 10° increments			

planning with glass fascias

The following should be considered when planning with glass fascia connections.

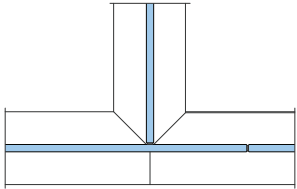
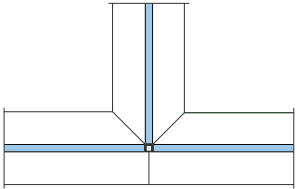
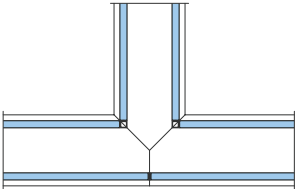
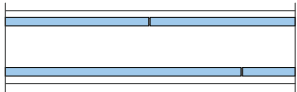
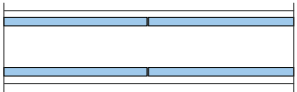
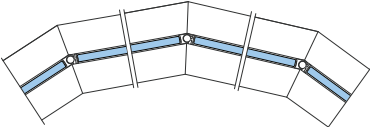
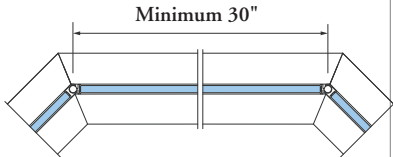
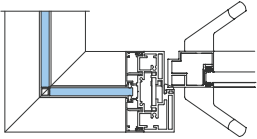
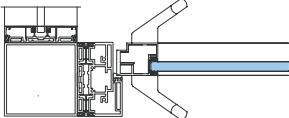
	Restriction 	Solution 1 	Solution 2 
<p>Three-way connections</p>  <p>Three-way corner connections cannot be planned off-module in center glass configurations.</p>	 <p>Three-way corner connections can be achieved using on-module center glass.</p>	 <p>Three-way on-module connection can also be achieved using double glass.</p>	
<p>In-line connectors</p>  <p>Inline double glass connections cannot be off module.</p>	 <p>On-module inline double glass connections can be used.</p>		
<p>Variable connections</p>  <p>The variable connector should not be used to create a glass wall of multiple small facets.</p>	 <p>The variable connector should be used to join long spans of linear glass fascias at angles. Only one glass fascia with two variable angle connectors can be used in the same run.</p>		
<p>Glass fascia widths</p>  <p>Glass fascia modules cannot be below 12" in width.</p>	 <p>Eliminate small glass fascia modules when possible (must ensure local building code requirements allow in door applications).</p>		

electrical filler panel fascia basics

The Electrical Filler Panel Fascia is used near door openings to house electrical switches and receptacles.

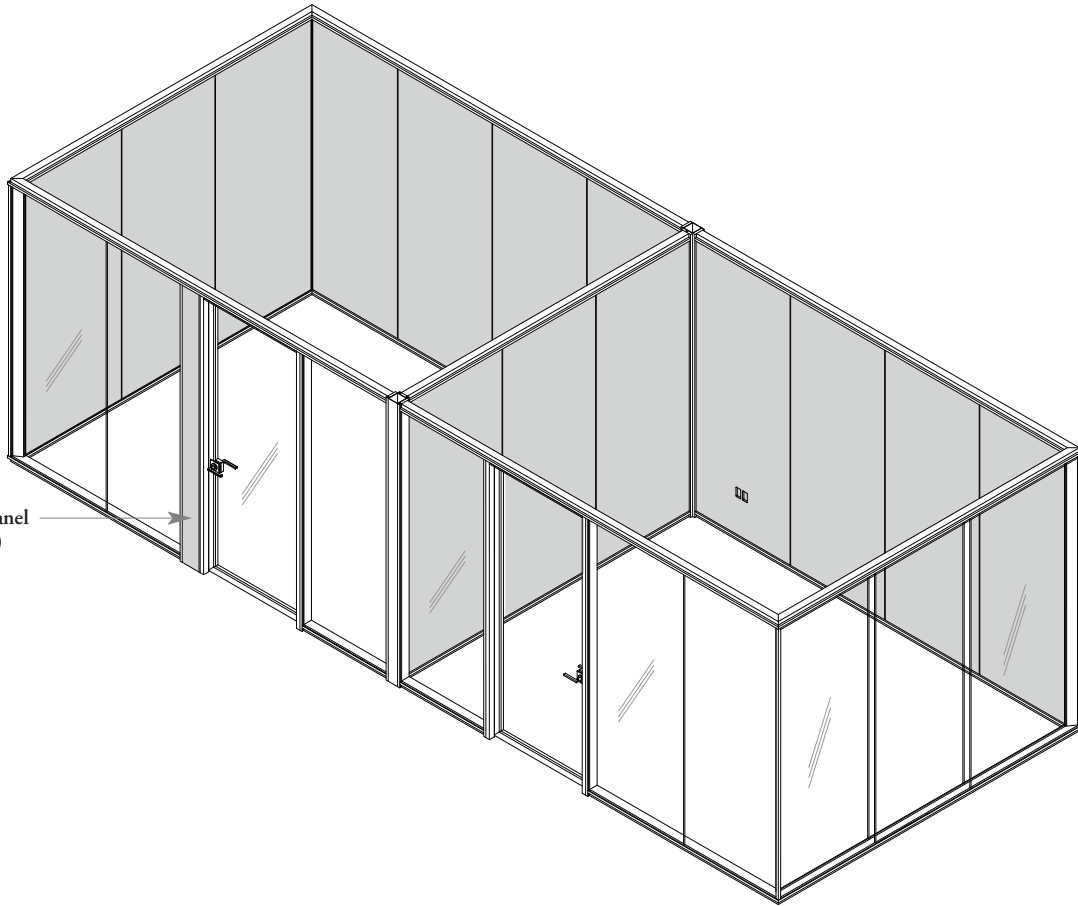

Electrical Filler Panel Fascia (FWEP)

Fascia finishes: Laminate, Flintwood and Veneer
Solid fascia finishes: Laminate, Flintwood and Veneer



Electrical Filler Panel Fascia (FWEP)

- Available styles include solid or one vertical cut out at 18" high
- Available heights include 84" - 120" in 1/16" increments

planning with electrical filler panel fascias

The following outlines the differences between Solid Fascia with 18" high cut out and Electrical Filler Panel Fascias.

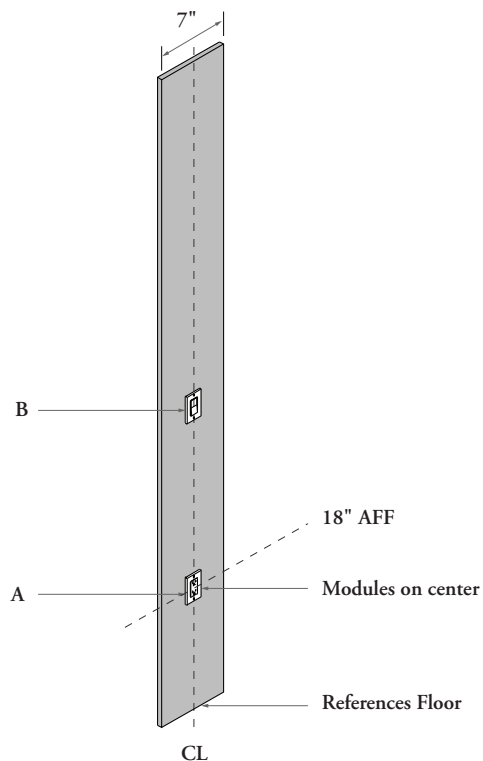
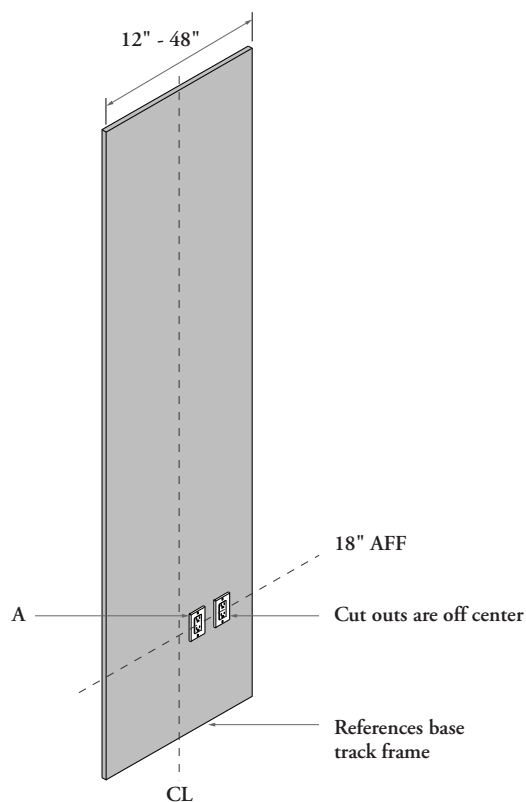

Solid Fascia – 18" Height Cut Out (FWS3)

- Used in solid monolithic wall runs to house receptacles
- Available in widths of 12" - 48"
- One or two electrical vertical cut outs can be specified on each side
- Cut outs are off-center for back to back electrical mounting

Electrical Filler Panel Fascia (FWEP)

- Typically used beside doors to house receptacles and switches
- Fixed panel width of 7"
- Only one electrical vertical cut out can be specified
- Cut outs are on-center for one sided electrical mounting (inside only)

Receptacle modules can be used on both the solid and electrical filler panel fascias, whereas the light module is only used in the electrical filler panel fascias. Please see the Accessories & Electrical section for more information.

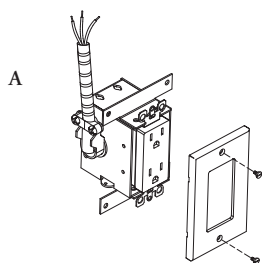

Receptacle Module (FWRM)

- Provides power to Focus walls when using the solid fascia with the 18" high cut out or with the electrical filler panel fascia
- Module mounts 18" above finished floor (AFF)
- The opening is always factory cut

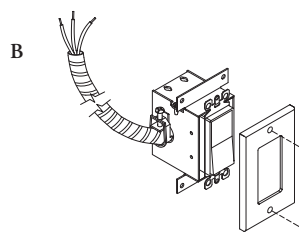

Light Module (FWLM)

- Provides a light module in Focus walls when using the Electrical Filler Panel fascia
- The opening is cut on-site

planning with electrical filler panel fascias (continued)

The following should be considered when planning with the Electrical Filler Panel Fascia.

The following images are shown from an interior view.

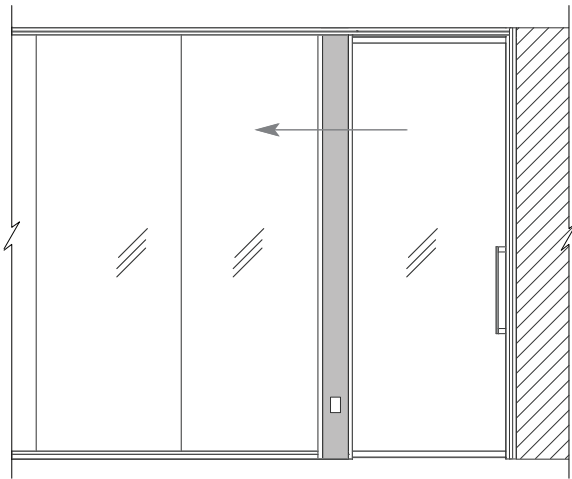

The Electrical Filler Panel Fascia should not be planned on the side where the door will slide, as it will interfere with the door

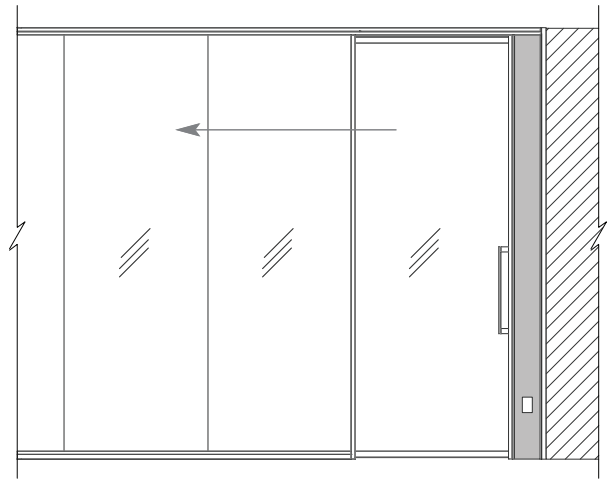

The Electrical Filler Panel Fascia should be planned on the opposite side.



The Electrical Filler Panel Fascia **cannot** be used between two different fascia types in the same run (example glass and solid).

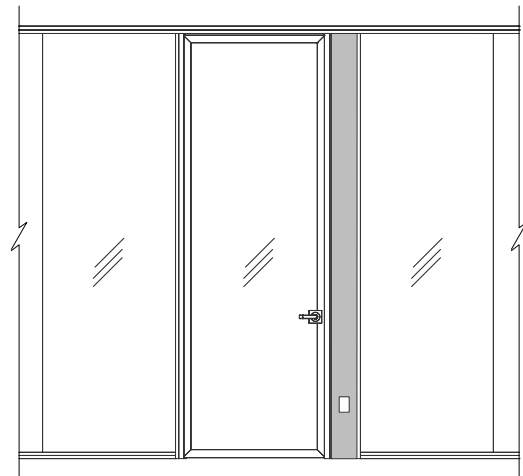

The Electrical Filler Panel Fascia must be used with two of the same fascia types in the same run (example: center glass and center glass).

planning with electrical filler panel fascias (continued)

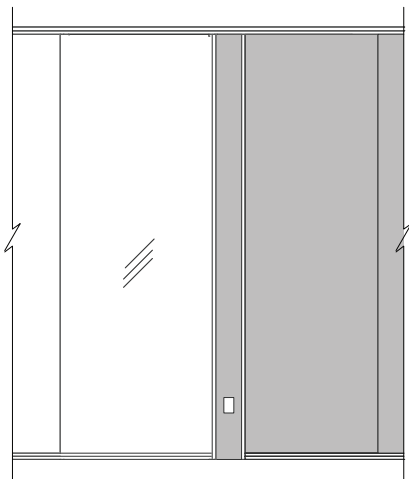

The Electrical Filler Panel Fascia **cannot** be used between two different fascia types in the same run (example: glass and solid). The fascia must be the same type.

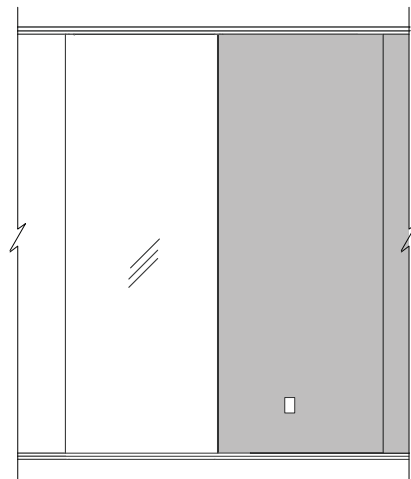

The Solid Fascia – 18" Height Cut Out should be used when transitioning between different fascias types (in the same run).

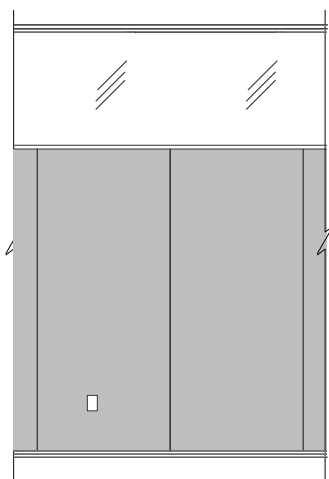

Electrical receptacles **cannot** be mounted directly below a clerestory application when power is coming from the ceiling.

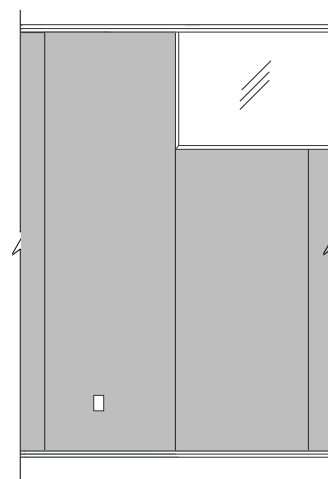

Specify electrical receptacles in a monolithic solid fascia adjacent to the clerestory application.

doors

doors

UNDERSTANDING DOORS	62
PIVOT DOOR & FRAME BASICS	63
PLANNING WITH PIVOT DOORS	64
PLANNING WITH PIVOT DOOR HARDWARE	66
SLIDING DOOR BASICS	67
PLANNING WITH SLIDING DOORS	68
PLANNING WITH SLIDING DOOR HARDWARE	74
HINGED DOOR & FRAME BASICS	75
PLANNING WITH HINGED DOORS	76
PLANNING WITH HINGED DOOR HARDWARE	78

understanding doors

Focus offers a variety of door styles that provide varying aesthetics and acoustic performance.

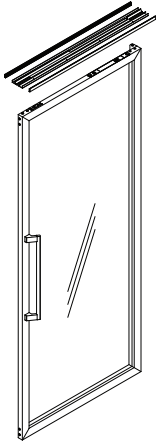

Pivot doors are composed of aluminum framed single or double glass to allow for varying levels of acoustic performance. Pivot mechanisms and hardware are integrated into the frame providing an uninterrupted visual.

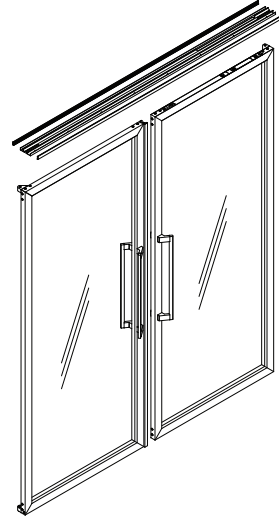

Double pivot doors are similar to single leaf pivot doors and are used for formal entrances or boardroom applications with high traffic flow.

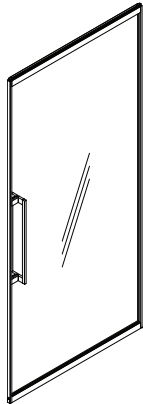

Sliding doors are ideal when floor space efficiency is required. They are center mounted and run parallel to the wall. Doors are composed of a glass panel with a minimal aluminum frame for hardware integration.

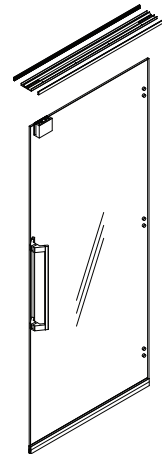

Hinged doors are monolithic and are composed of either frameless glass or a solid wood slab. Hinge mechanisms and hardware are exposed, creating a door with a pronounced visual expression.

pivot door & frame basics

Pivot doors are a framed glass door with concealed hardware that provides an uninterrupted aesthetic to a Focus wall.

- Available in nominal heights from 96" – 120" with the ability to specify in 1/16" increments
- Available with or without a kickplate
- Available with or without a door drop seal to allow for additional acoustic
- Available with or without soft close
- Available left or right handed
- Available cut conditions include no strike for a pull or with strike for a lever

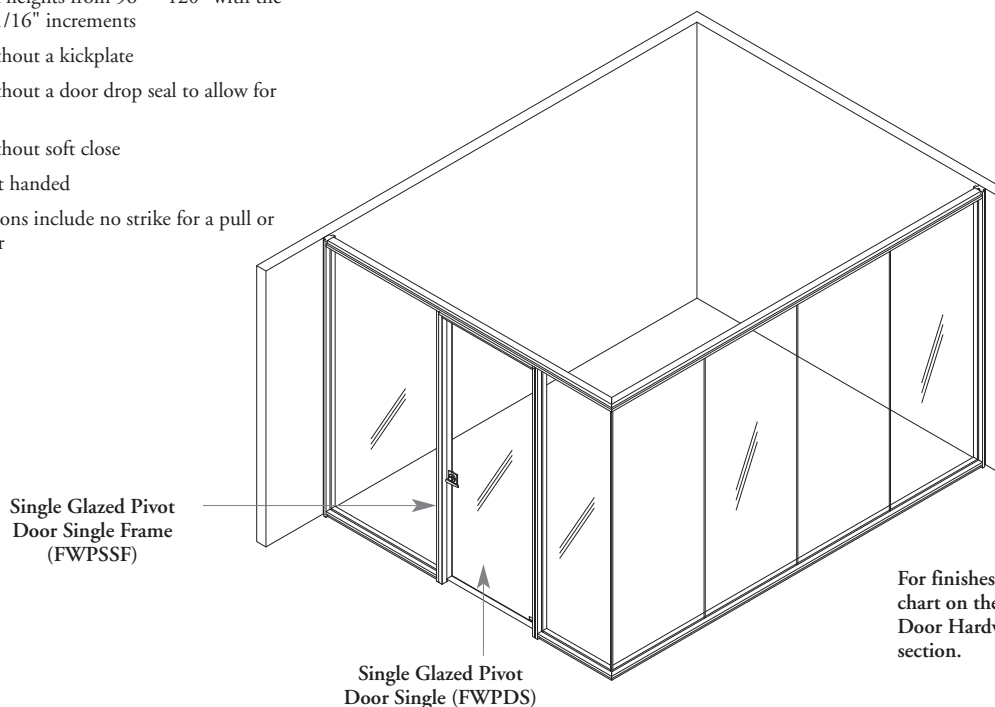

For finishes, please refer to the chart on the Planning with Pivot Door Hardware page in this section.

63

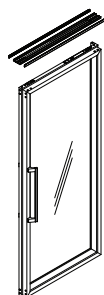

Double Glazed Pivot Door Single (FWDDSD)

- A pair of framed pivot door with a 100mm frame and two 8mm glass panels
- Clear opening is 34-1/4" (870mm) wide

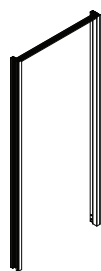

Double Glazed Pivot Door Single Frame (FWPDDSF)

- Frame for double glazed pivot door, consists of two vertical jamb extrusions
- Frame width is 42"

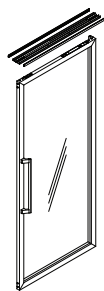

Single Glazed Pivot Door Single (FWPDS)

- A framed pivot door with a 45mm frame and a single 12mm glass panel
- Clear Opening is 36-7/16" (925mm) wide

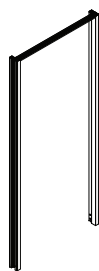

Single Glazed Pivot Door Single Frame (FWPSSF)

- Frame for single glazed pivot door, consists of two vertical jamb extrusions
- Frame width is 42"

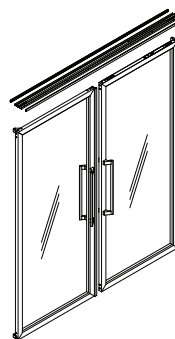

Single Glazed Pivot Door – Double (FWPDD)

- A pair of framed double pivot doors with a 45mm frame and single 12mm glass panel
- Right hand door is always active, left door is inactive
- Clear Opening is 74" (1880mm) wide

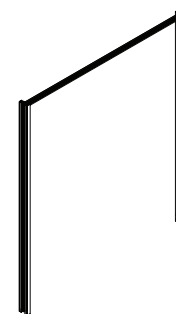

Single Glazed Pivot Door Double Frame (FWPDDSF)

- Frame for single glazed pivot door, double frame consists of two vertical jamb extrusions
- Frame width is 84"

planning with pivot doors

The following outlines the features of pivot doors.

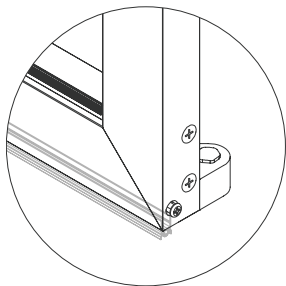
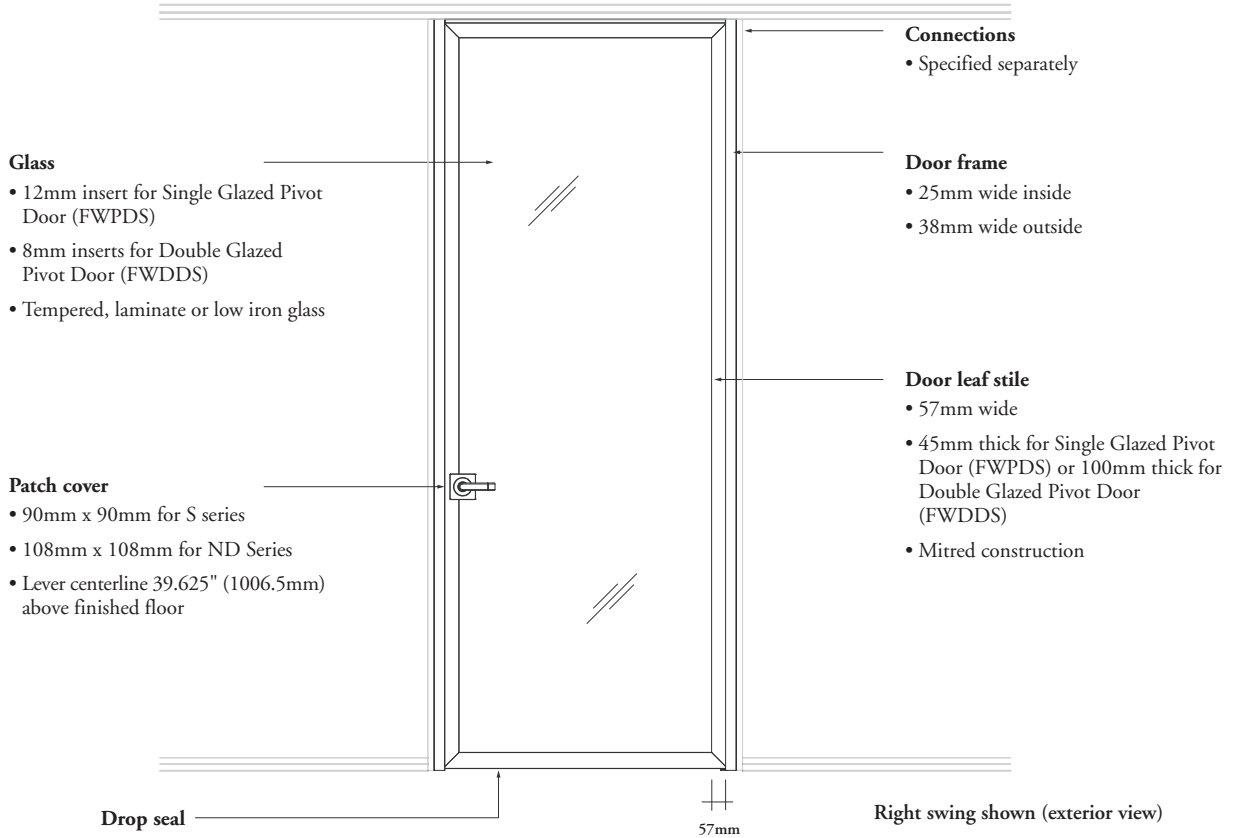

Drop seal

- Actuator pin drops seal when door is closed against jamb and allows for additional acoustics
- Maximum drop of 11mm
- Casing finished in Clear Anodized only

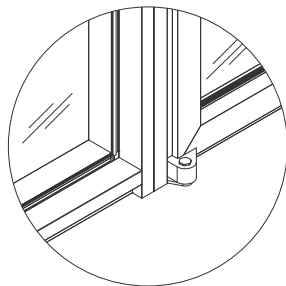

Pivot mechanism (interior view)

- One pivot on top of door and one on bottom
- Finished to match frame

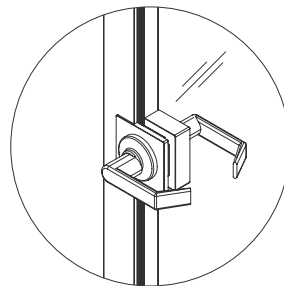

Patch cover (exterior view)

- Aluminum construction
- No exposed fasteners
- Finished to match frame

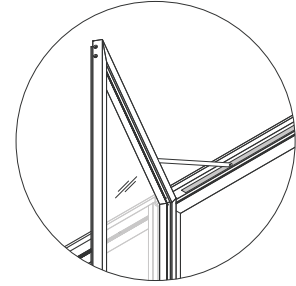

Door closer

- Optional
- Concealed closer
- Adjustable closing speed
- Closer Arm and track finished in Clear Anodized only
- Hold Open feature is **not** included as standard with the Soft Close Mechanism

planning with pivot doors (continued)

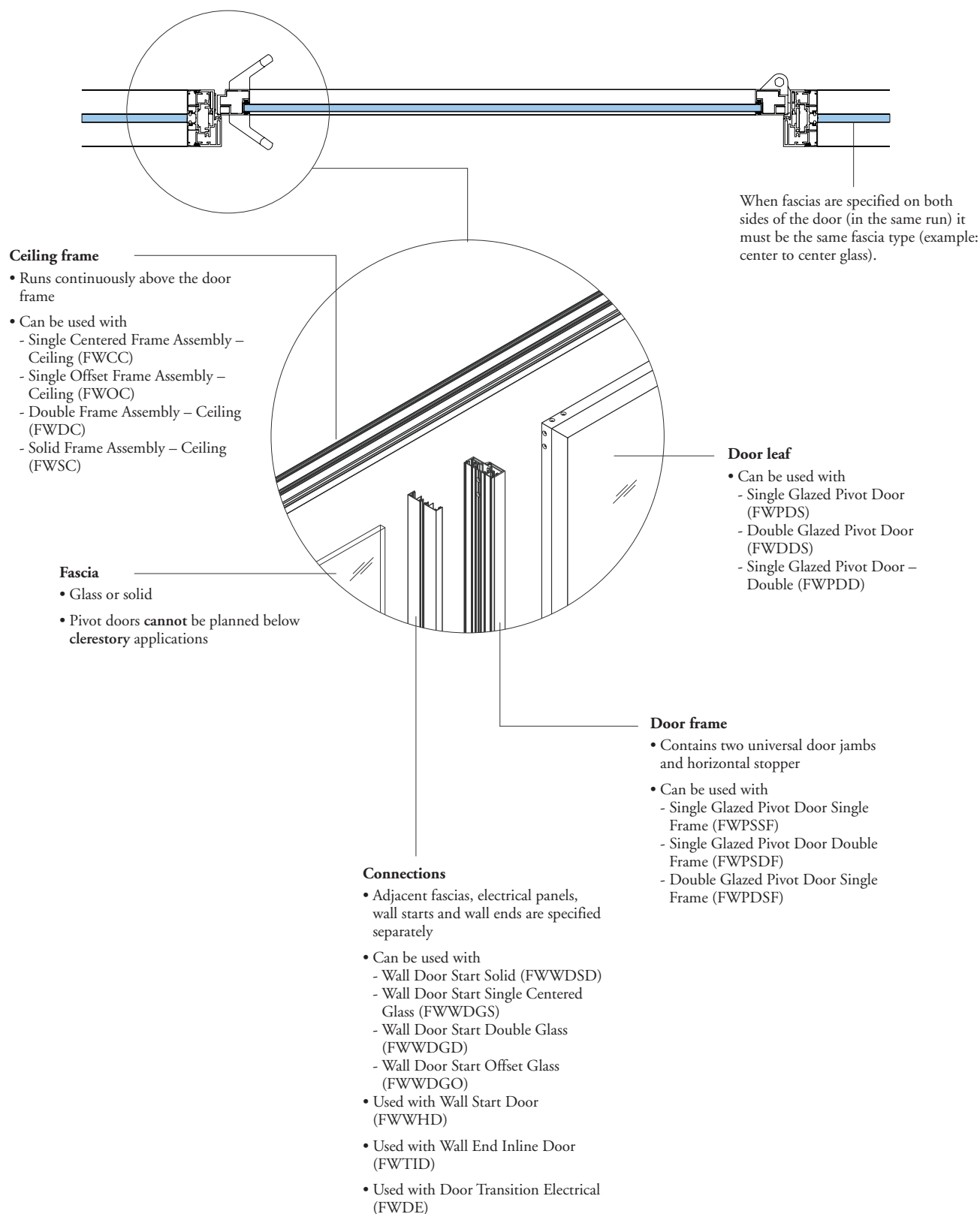

planning with pivot door hardware

The following outlines the hardware offering for Focus pivot doors.

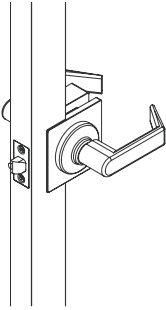
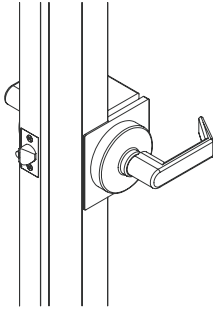
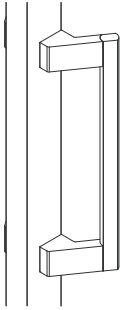
			
Supplier	Schlage	Schlage	Teknion
Series	S	ND	Integrated Pull
Lever/pull types	Saturn	Rhodes	Square
Function options	<ul style="list-style-type: none"> • Dummy • Passage • Standard lock and interchangeable core cylinder 	<ul style="list-style-type: none"> • Dummy • Passage • Standard lock and interchangeable core cylinder 	<ul style="list-style-type: none"> • 13" • 24"
Function details	Cylindrical Lock / Latch	Cylindrical Lock / Latch	Non - Locking
Code Compliance	ADA	ADA	ADA
Finish options	Satin Chrome	Satin Chrome	Can match all standard door frame finishes except Very White.
Pivot door compatibility	Single Glazed Pivot Door (FWPDS) only	Double Glazed Pivot Door (FWDDS) only	All pivot doors

- Hardware patch covers are matched to door frame finish
- Doors specified with “interchangeable core cylinder” are keyed randomly (two keys provided per door) but can be removed by a universal control (one key provided per door)
- After installation, customers may chose to relocate or replace interchangeable core cylinders to suit their security needs

sliding door basics

Sliding doors provide a space saving solution by running parallel to the wall. The sliding door frame can be integrated into adjacent horizontal frames for a continuous storefront aesthetic.

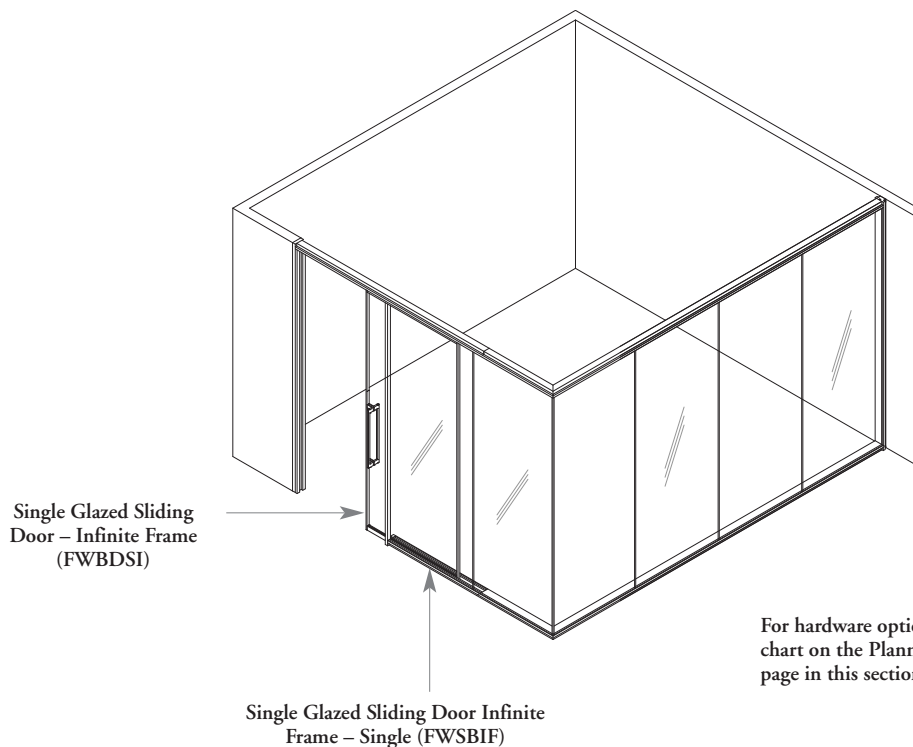

For hardware options and finishes, please refer to the chart on the Planning with Sliding Door Hardware page in this section.

67

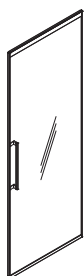

Single Glazed Sliding Door – Infinite Frame (FWBDSI)

- A framed sliding door with a 26mm thick frame and a single 10mm glass panel
- Available for ceiling heights 96" – 120" in 1/16" increments
- Available with a left or right door slide
- Available with or without drop seal
- Clear Opening is 36" (915mm) wide

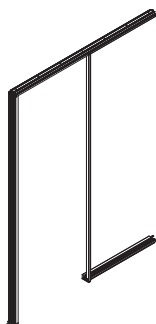

Single Glazed Sliding Door Infinite Frame – Single (FWSBIF)

- Frame consists of top and base sliding rail, front and back jamb
- Can be spliced into standard horizontal frames
- Available with configurable rail length of 84" – 95-15/16" wide
- Frame supports offset glass sidelite fascia only (Glass Fascias (FWGA/FWGB) must be specified separately)



Double Glazed Sliding Door Infinite Frame – Single (FWDBIF)

- Frame consists of top and base sliding rail, front and back jamb
- Can be spliced into standard horizontal frames
- Available with configurable rail length of 84" – 95-15/16" wide
- Frame supports double glass sidelite fascia only (Glass Fascias (FWGA/FWGB) must be specified separately)

planning with sliding doors

The following outlines the features of sliding doors.

Both locking and non-locking versions of the barn door are available. Doors are handed and the handedness is determined by the direction that the door slides.

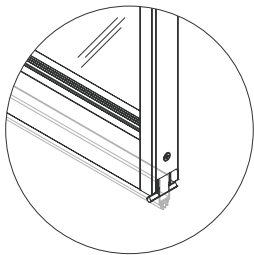
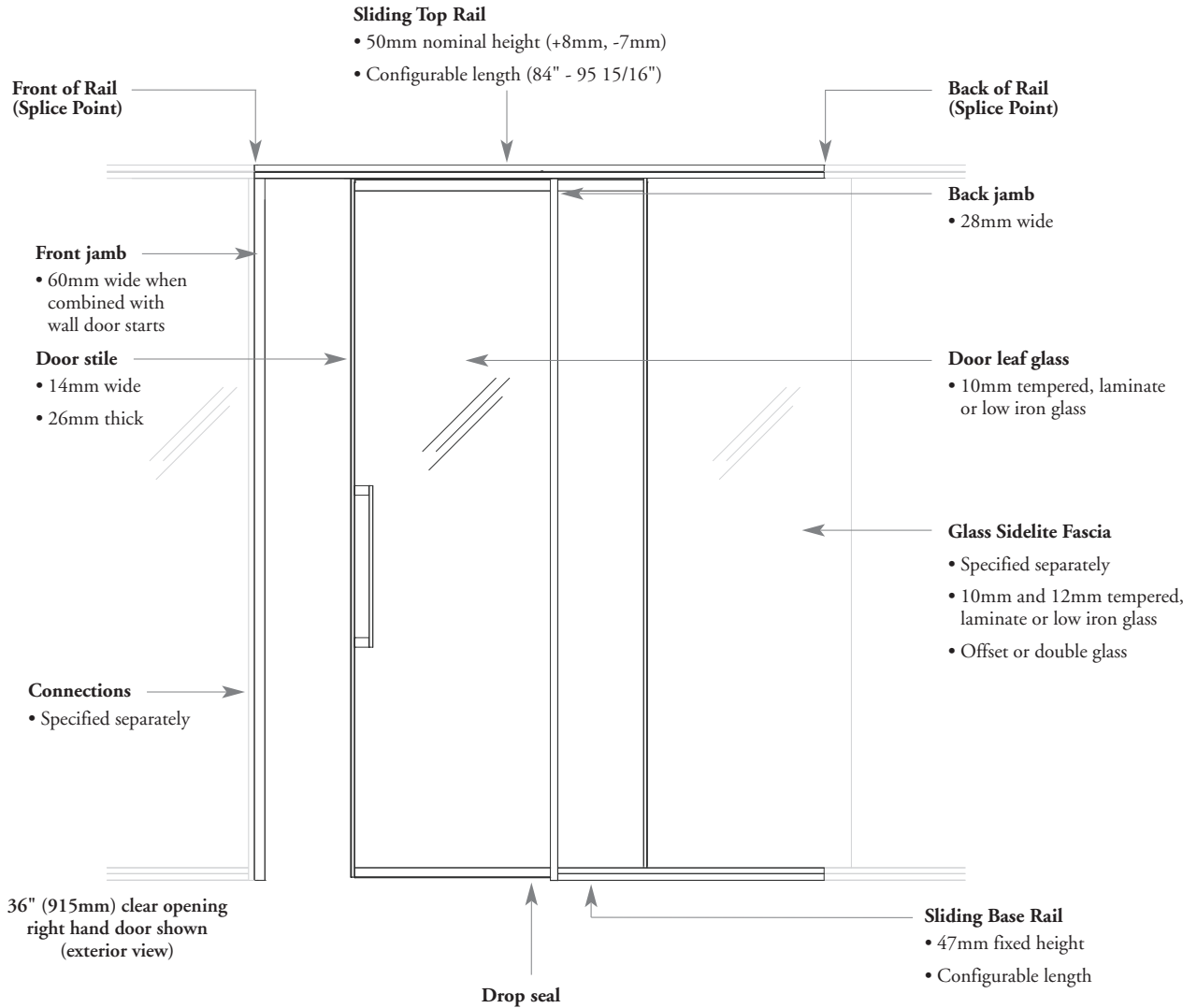

Drop seal

- Actuator lever drops seal in closed position
- Maximum drop of 18mm
- Casing finished in Clear Anodized only

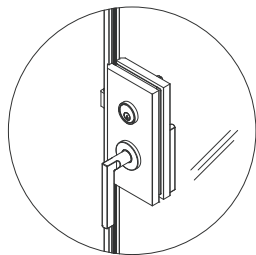

Patch cover (exterior view)

- Aluminum construction
- No exposed fasteners
- Finish to match frame

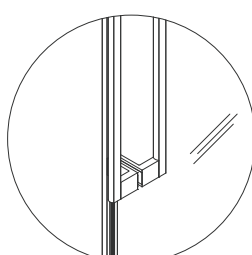

Pull

- Aluminum construction
- Adhered with tape
- Proportions match door stile

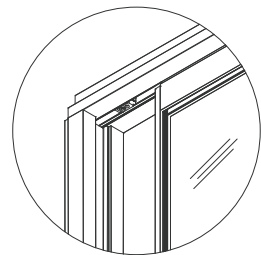

Soft close roller

- Standard offering
- +/- 3mm of levelling
- Center mounted on frame

planning with sliding doors (continued)

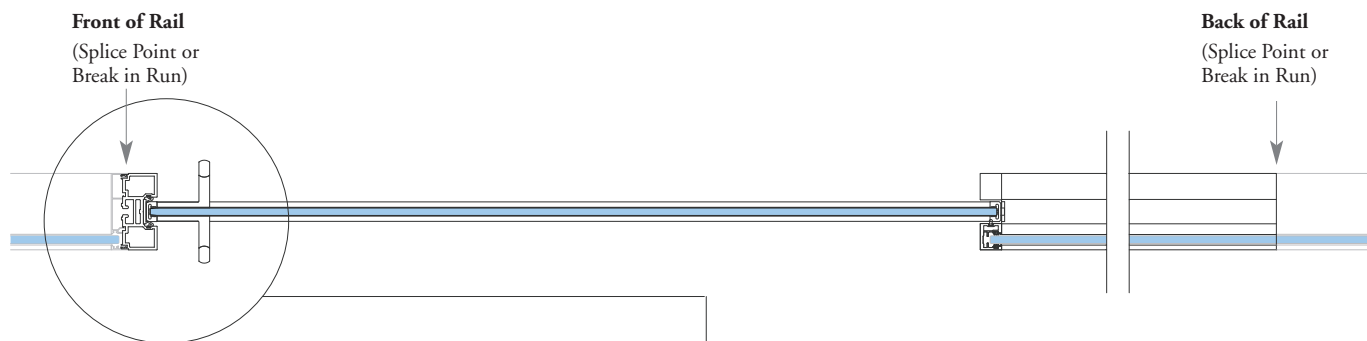

Horizontal Frames

- Adjacent horizontal frames can be planned in two ways:
 1. Spliced into the sliding rail (same run)
 2. Separate from the sliding rail (break in run)
- The following frame types can be spliced to the front of the sliding rail:
 - Single Centered Frame Assembly – Ceiling (FWCC)
 - Single Offset Frame Assembly – Ceiling (FWOC)
 - Double Frame Assembly – Ceiling (FWDC)
 - Solid Frame Assembly – Ceiling (FWSC)
- The following frame types can be spliced to the back of the sliding rail:
 - Single Offset Frame Assembly – Ceiling (FWOC)/Single Offset Frame Assembly – Base (FWOB)
 - Double Frame Assembly – Ceiling (FWDC)/Double Frame Assembly – Base (FWDB)
- Any frame type can be applied on either side when separated from the sliding rail (break in run)

Fascias

- The following fascias can be applied directly to the front of the sliding rail:
 - Glass Fascia – 10mm Thickness (FWGA)
 - Glass Fascia – 12mm Thickness (FWGB)
 - Solid Fascia (FWS1)
 - Solid Fascia – 18" Height Cut Out (FWS3)
 - Electrical Filler Panel Fascia (FWEP)
- The following fascias can be applied directly to the back of the sliding rail:
 - Glass Fascia – 10mm Thickness (FWGA)
 - Glass Fascia – 12mm Thickness (FWGB)
- Clerestory applications cannot be planned in the same run as the sliding door frame

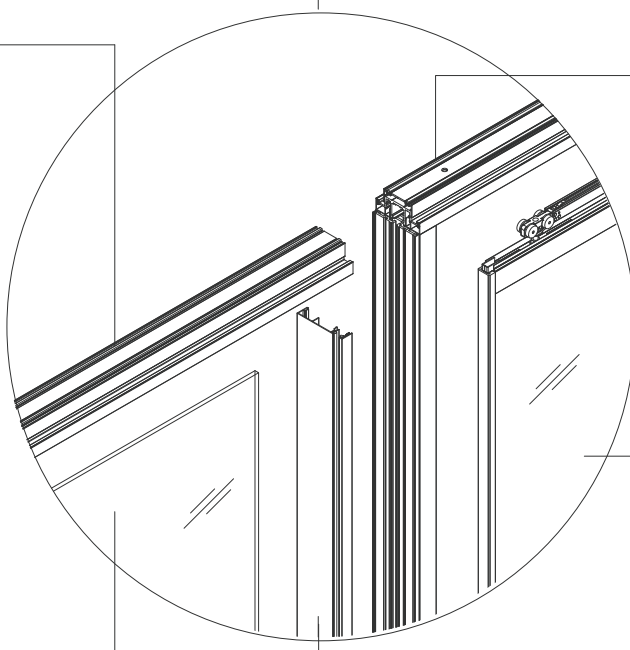

Sliding Door Frame

- Single Glazed Sliding Door Infinite Frame – Single (FWSBIF), Double Glazed Sliding Door Infinite Frame – Single (FWDBIF)
- Frame consists of top and base sliding rail, front and back jamb

Sliding Door Leaf







- Single Glazed Sliding Door – Infinite Frame (FWBDSI)

Connections

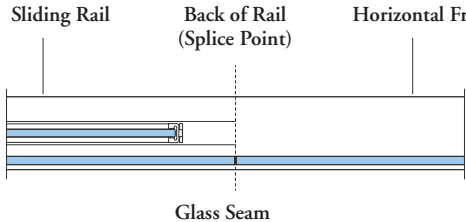

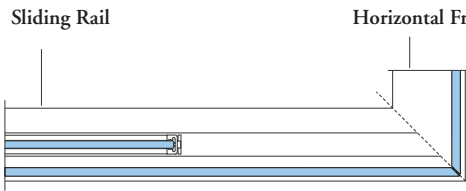

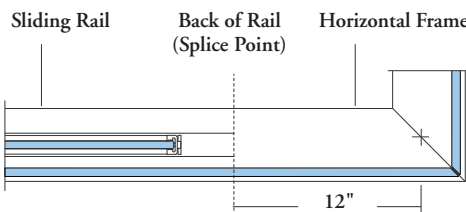

- The following can be applied directly to the front of the sliding rail:
 - Wall Door Start Solid (FWWDSD)
 - Wall Door Start Single Centered Glass (FWWDGS)
 - Wall Door Start Double Glass (FWWDGD)
 - Wall Door Start Offset Glass (FWWDGO)
 - Wall Start Door (FWWHD)
 - Wall End Inline Door (FWTID)
 - Door Transition Electrical (FWDE)
- The following can be applied directly to the back of the sliding rail:
 - Wall Start Single Offset Glass (FWWGO)
 - Wall Start Double Glass (FWWGD)
 - Wall End Inline Offset Glass (FWWO)
 - Wall End Inline Double Glass (FWWD)
 - Inline Transition Connection – Offset Glass to Offset Glass (FWTIGOGO)
 - Inline Transition Connection – Double Glass to Double Glass (FWTIGDGD)
 - Inline Transition Connection – Single Centered Glass to Single Offset Glass (FWTIGSGO)
 - Inline Transition Connection – Double Glass to Single Glass (FWTIGDGS)
 - Inline Transition Connection – Double Glass to Offset Glass (FWTIGDGO)

planning with sliding doors (continued)

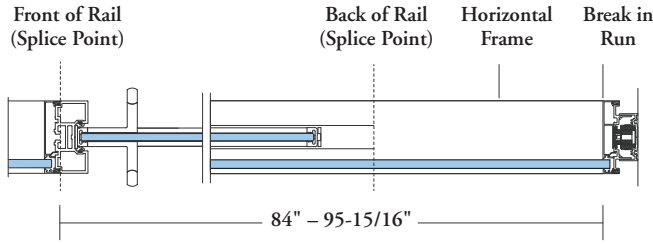
The following should be considered when planning with sliding doors.

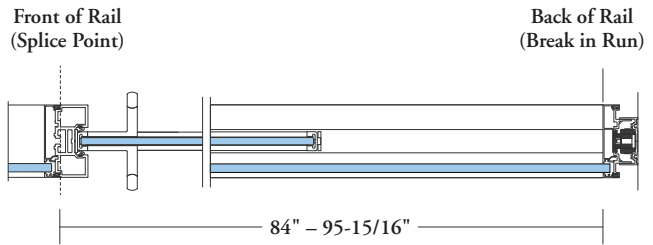

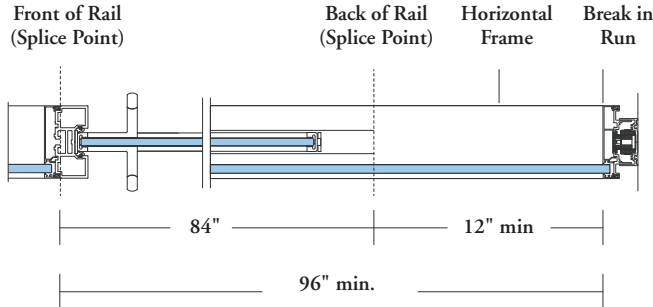



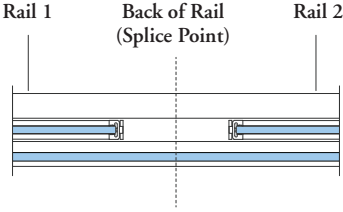

<p>The glass sidelite fascia can be off-module from the splice point, depending on the specific run length. Glass is optimized to be same width.</p>		
<p>The glass sidelite fascia can be on-module from the splice point, depending on the specific run length. Glass is optimized to be same width.</p>		
<p>The sliding rail cannot be spliced directly to create a corner joint (90°, Three-Way, Four-Way) or variable angle.</p>		
<p>The sliding rail can be spliced to create an inline joint. An adjacent horizontal frame is required to create a corner joint (90°, Three-Way, Four-Way) or variable angle. The adjacent horizontal frame must be 12" minimum in length.</p>		

planning with sliding doors (continued)

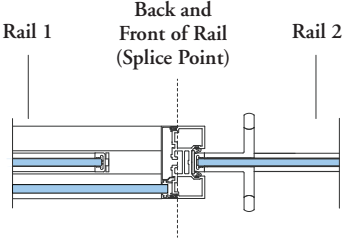
<p>A horizontal frame cannot be spliced to the back of the rail when the overall run length is between 84" – 95-15/16"</p>		
<p>The sliding rail length must be configured when the overall run length is between 84" – 95-15/16"</p>		
<p>Use the minium configurable rail length (84") when the overall run length is 96" or greater.</p>		

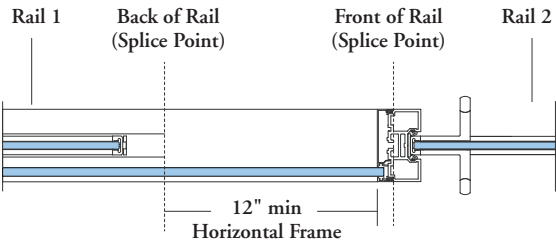
planning with sliding doors (continued)

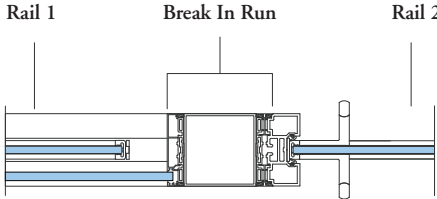
72

<p>The back rails of two sliding door frames can be adjacent to each other if required.</p>		
<p>The back and front rail of two sliding door frames cannot be spliced directly.</p>		
<p>The back and front rails of two sliding door frames can be spliced with a section of horizontal framing. The horizontal frame must be 12" minimum in length.</p>		
<p>The back and front rails of two sliding door frames can be separated with a break in run.</p>		

planning with sliding doors (continued)

Additional ceiling structure is required to accommodate the top rail of the sliding door. The structure above the ceiling is the responsibility of the General Contractor and must be installed in advance. Below is a general diagram of the type of structure required. Please review with Teknion if needed.

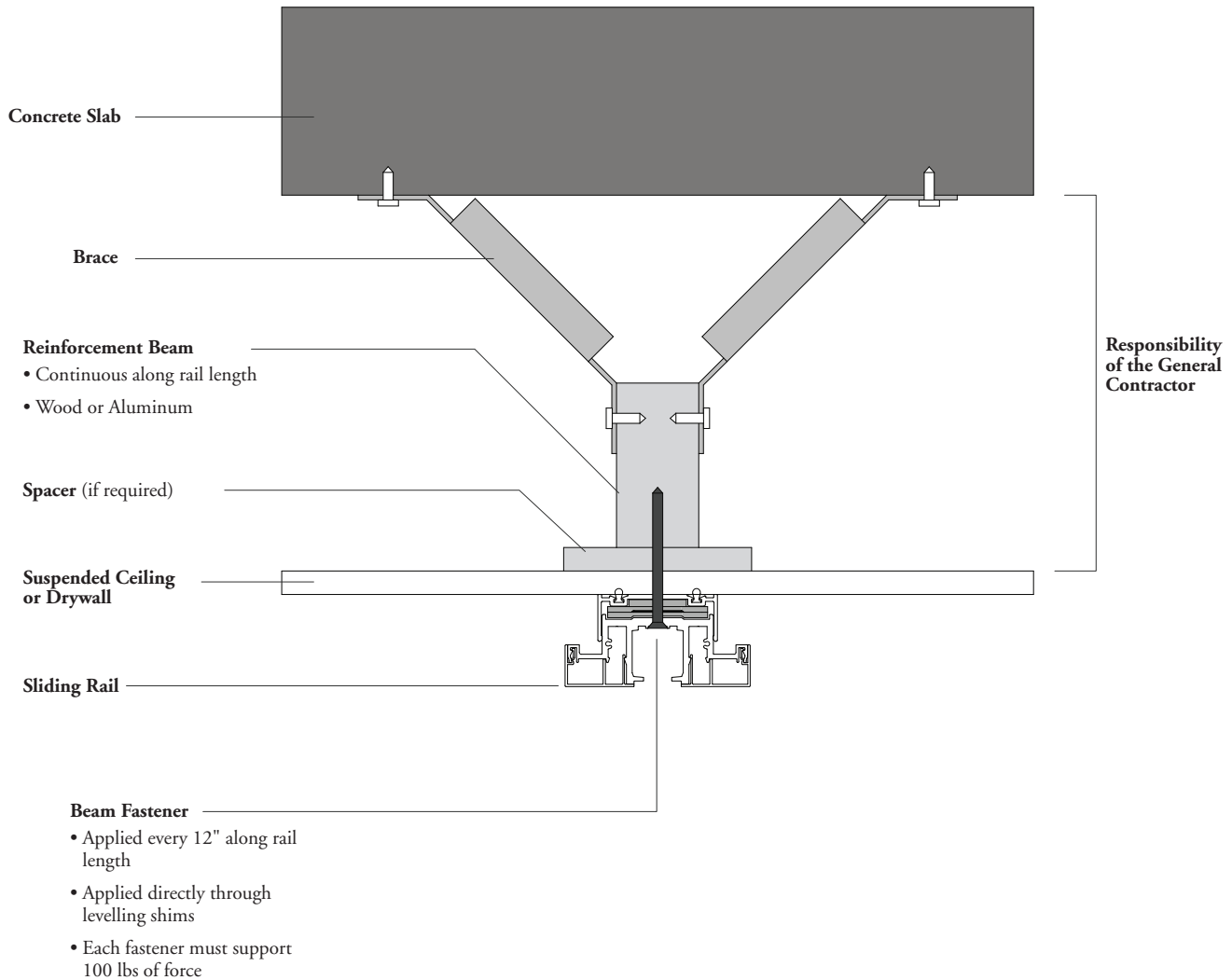

planning with sliding hardware

The following outlines the hardware offering for Focus sliding doors.

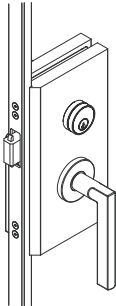
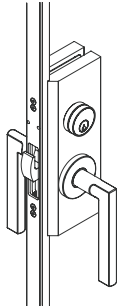
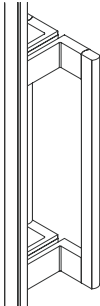
			
Supplier	FSB	Adams Rite / FSB	Teknion
Series	SLL	MS 1850S-450 / HLL Dummy	Integrated pull
Lever/pull types	1035 (Static outside)	1035 (Static both sides)	Square
Function options	Standard lock and interchangeable core cylinder	Standard lock and interchangeable core cylinder	<ul style="list-style-type: none"> • 13" • 24"
Function details	Single action egress dormitory lock	Deadlock	Non-locking
Code Compliance	<ul style="list-style-type: none"> • ADA • Fire Rated 	ADA	ADA
Finish options	Polished Aluminum (lever and thumb turn)	Polished Aluminum (lever only)	Can match all standard frame finishes except Very White.

- Hardware patch covers are matched to door frame finish
- Lock cylinder finished in Satin Chrome is standard
- Doors specified with “interchangeable core cylinder” are keyed randomly (two keys provided per door) but can be removed by a universal control (one key provided per door)
- After installation, customers may chose to relocate or replace interchangeable core cylinders to suit their security needs

hinged door & frame basics

Focus hinged doors are frameless and are available in glass or wood.

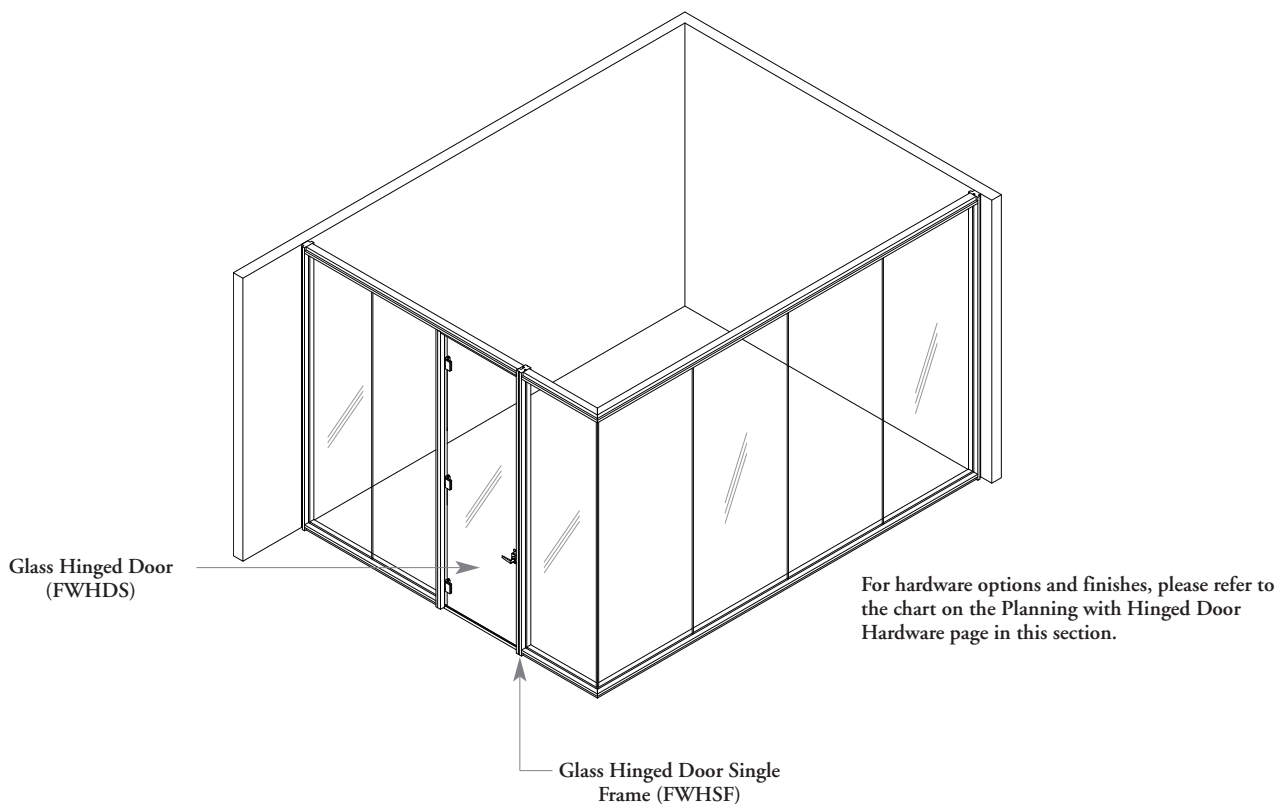

75

- Available in nominal lengths from 83" – 120" with the ability to specify in 1/16" increments
- Frame width is 42" nominal
- Available with left or right door swing
- Available cut conditions include no strike for a pull or with strike for a lever
- Available with or without door drop seal

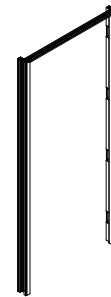
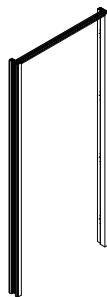
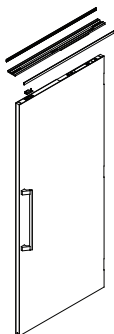
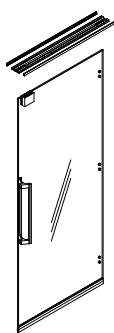
**Glass Hinged Door (FWHDS)**

- Frameless glass door includes three or four exposed hinge/patch covers
- Available glass thicknesses include 10mm and 12mm
- Clear Opening is 37-1/8" (943mm) wide

Solid Hinged Door (FWSDS)

- Solid wood slab door consists of three or four hinges
- Available with or without soft close
- Clear opening is 37" (941mm) wide

Glass Hinged Door Single Frame (FWHSF)

- Frame for glass hinged door consists of two vertical jambs

Solid Hinged Door Single Frame (FWSSF)

- Frame for solid hinged door consists of two vertical jambs

planning with hinged doors

The following outlines the features of hinged doors.

Connections

- Specified separately

Frameless glass

- 10mm or 12mm tempered, laminate or low iron glass

Patch cover

- 90mm x 117mm
- Lever CL 39.625" (1006.5mm) AFF

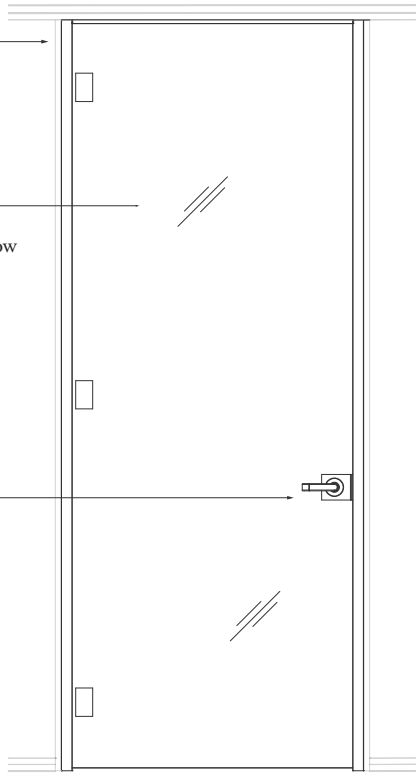

Left swing shown
(exterior view)

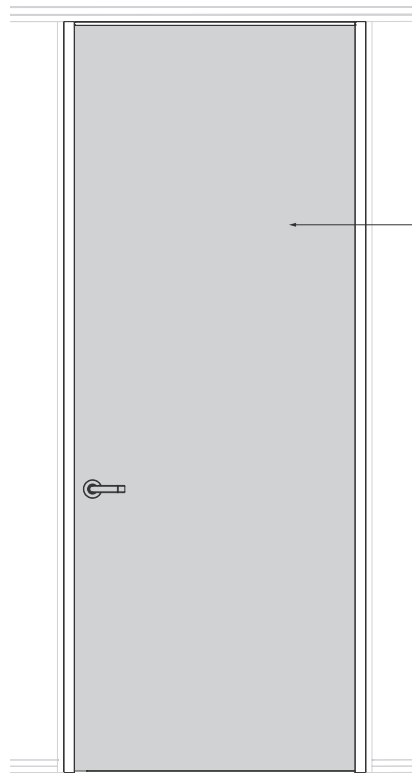

Solid slab

- 45mm thick

Drop seal

Right swing shown
(exterior view)

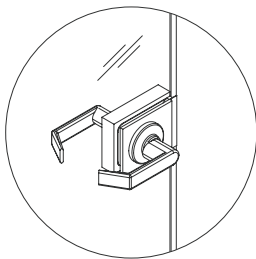

Patch cover (exterior view)

- Aluminum construction
- No exposed fasteners
- Finished to match frame

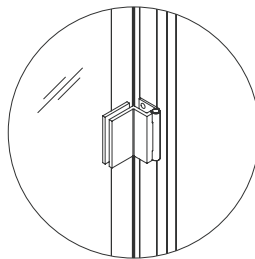

Frameless hinge (Interior view)

- Heights up to 108" have three hinges and heights greater than 108" have four hinges
- Clear or Brushed Black Anodized finish

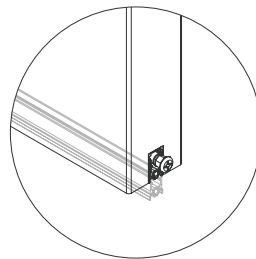

Drop seal

- Optional
- Actuator pin drops seal when door is closed against jamb
- Maximum drop of 11mm
- Casing finished in Clear Anodized only

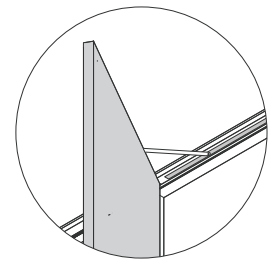

Door closer

- Optional (Solid door only)
- Concealed closer
- Adjustable closing speed
- Closer Arm and track finished in Clear Anodized only
- Hold Open feature is **not** included as standard with the Soft Close Mechanism

planning with hinged doors (continued)

The following should be considered when planning with hinged doors.

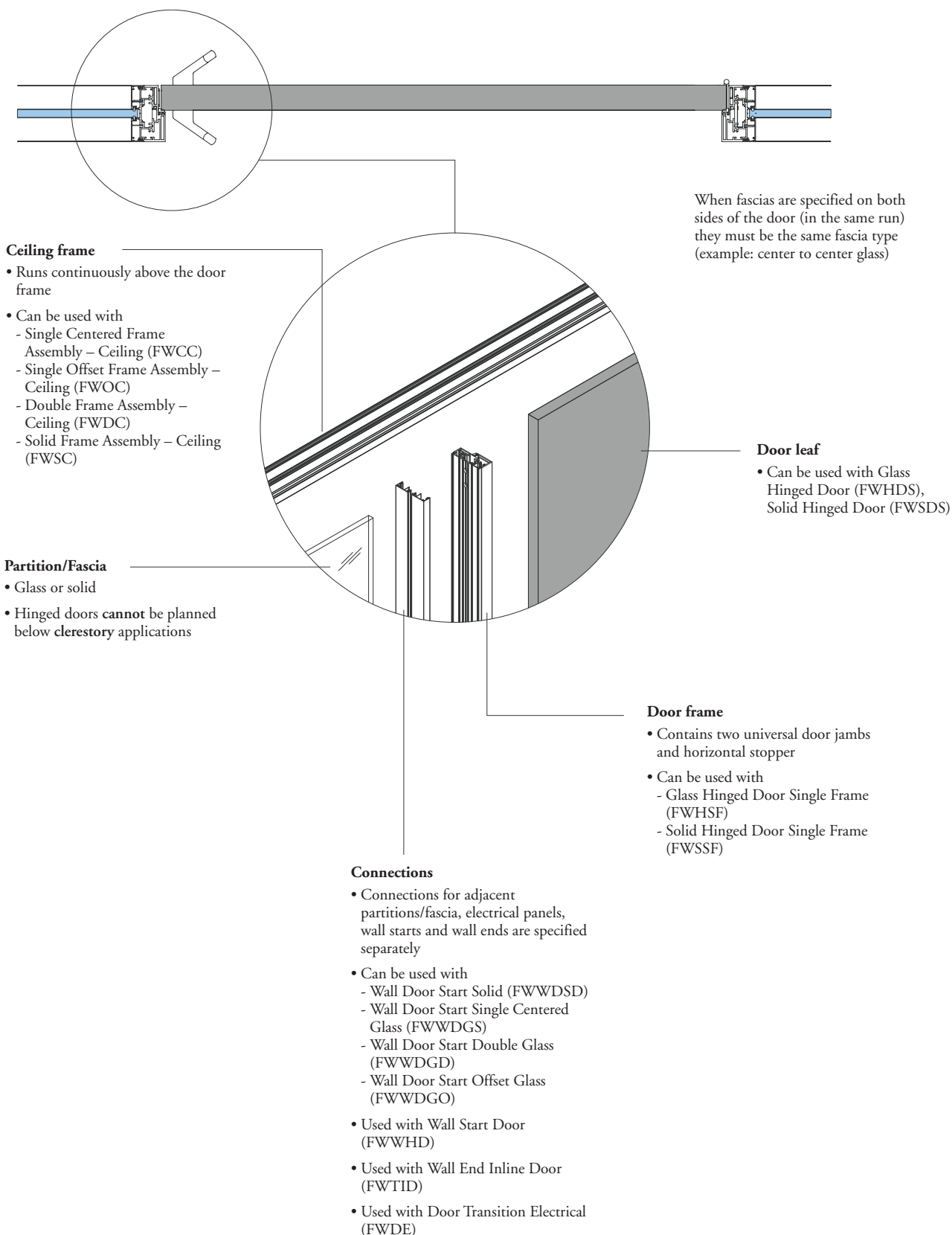

planning with hinged door hardware

The following outlines the hardware offering for Focus hinged doors.

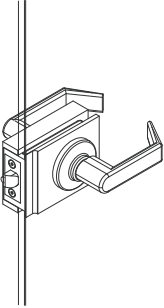
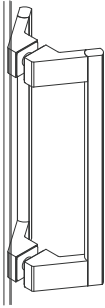
		
Supplier	Schlage	Teknion
Series	S	Integrated pull
Lever/pull types	Saturn	Square
Function options	<ul style="list-style-type: none"> • Dummy • Passage • Standard lock and interchangeable core cylinder 	<ul style="list-style-type: none"> • 13" • 24"
Function Details	Cylindrical Lock/Latch	Non-Locking
Code Compliance	ADA	ADA
Finish options	Satin Chrome	Can match all standard frame finishes except Very White.
Hinged door compatibility	Frameless and solid	Frameless and solid

- Hardware patch covers are matched to door frame finish
- Doors specified with “interchangeable core cylinder” are keyed randomly (two keys provided per door) but can be removed by a universal control (one key provided per door)
- After installation, customers may chose to relocate or replace interchangeable core cylinders to suit their security needs

wall starts & wall ends

wall starts & wall ends

WALL START BASICS	82
PLANNING WITH WALL STARTS	83
WALL DOOR START BASICS	84
PLANNING WITH WALL DOOR STARTS	85
WALL END BASICS	86
PLANNING WITH WALL ENDS	87

wall start basics

Focus offers a variety of wall starts that allow glass and solid fascias to connect to architectural walls.

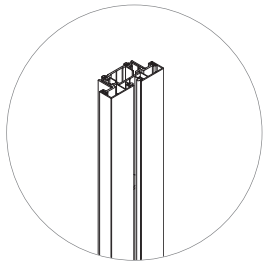
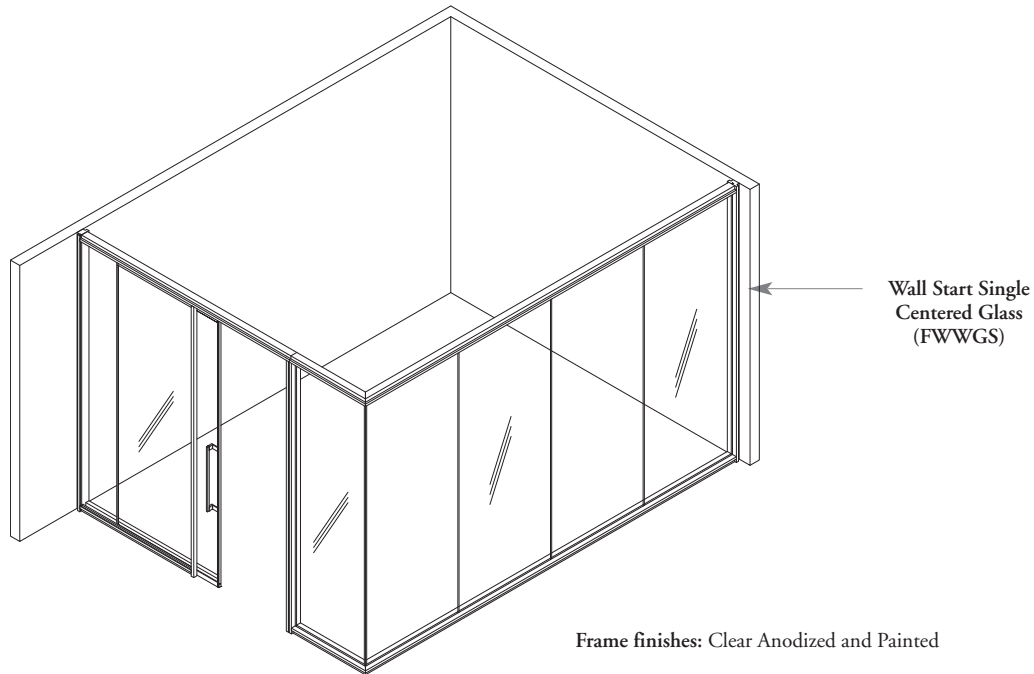

Wall Start Single Centered Glass (FWWGS)

- Adjustable wall start for monolithic single centered glass fascias against drywall

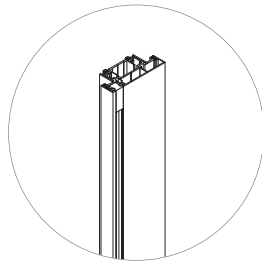

Wall Start Single Offset Glass (FWWGO)

- Adjustable wall start for monolithic single offset glass fascias against drywall

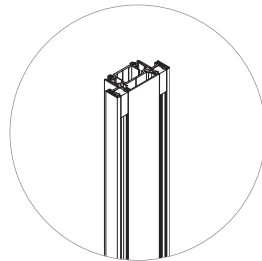

Wall Start Double Glass (FWWGD)

- Adjustable wall start for monolithic double glass fascias against drywall

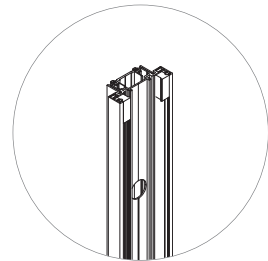

Wall Start Solid (FWWSD)

- Adjustable wall start for monolithic solid fascias against drywall

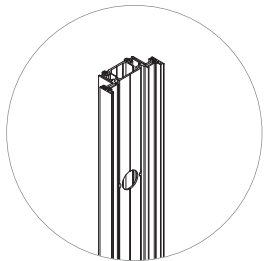

Wall Start Door (FWWHD)

- Adjustable wall start for pivot/hinged/barn doors against drywall

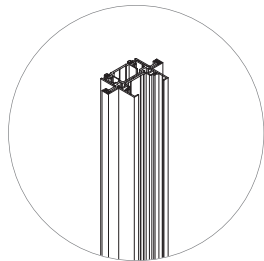

Wall Start Electrical (FWWE)

- Adjustable wall start for electrical filler panel against drywall

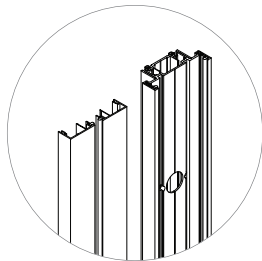

Wall Start Single Centered Glass - Framed (FWWGSF)

- Adjustable wall start for clerestory with single centered glass

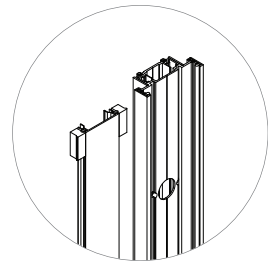

Wall Start Double Glass - Framed (FWWGDF)

- Adjustable wall start for clerestory with double glass

wall starts & wall ends

planning with wall starts

The following outlines the application for each wall start type.

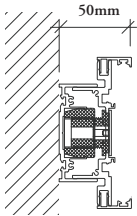

Drywall

All wall starts have a nominal width of 50mm, Wall Start Solid (FWWSD) (shown), excluding the Wall Start Electrical (FWWE) which has a nominal width of 39mm

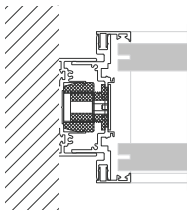

Wall Start Solid (FWWSD)
Can be used with solid monolithic against drywall

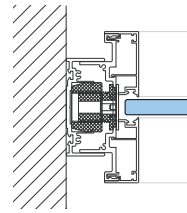

Wall Start Single Centered Glass (FWWGS)
Can be used with center glass fascias against drywall

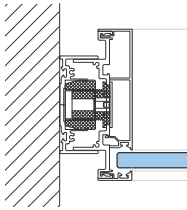

Wall Start Single Offset Glass (FWWGO)
Can be used with offset glass fascias against drywall

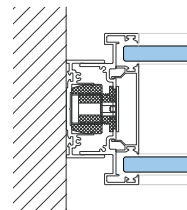

Wall Start Double Glass (FWWGD)
Can be used with double glass fascias against drywall

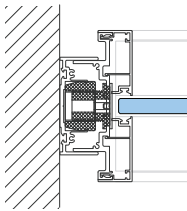

Wall Start Single Centered Glass - Framed (FWWGSF)
Can be used with center glass clerestory against drywall

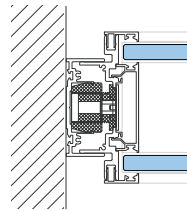

Wall Start Double Glass - Framed (FWWGDF)
Can be used with double glass clerestory against drywall

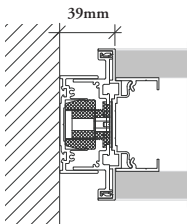

Wall Start Electrical (FWWE)
Can be used with electrical panel against drywall

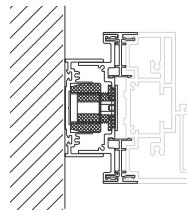

Wall Start Door (FWWHD)
Can be used with any pivot or hinge door frame against drywall

wall door start basics

Focus offers a variety of wall door starts that allow doors to connect to architectural walls.

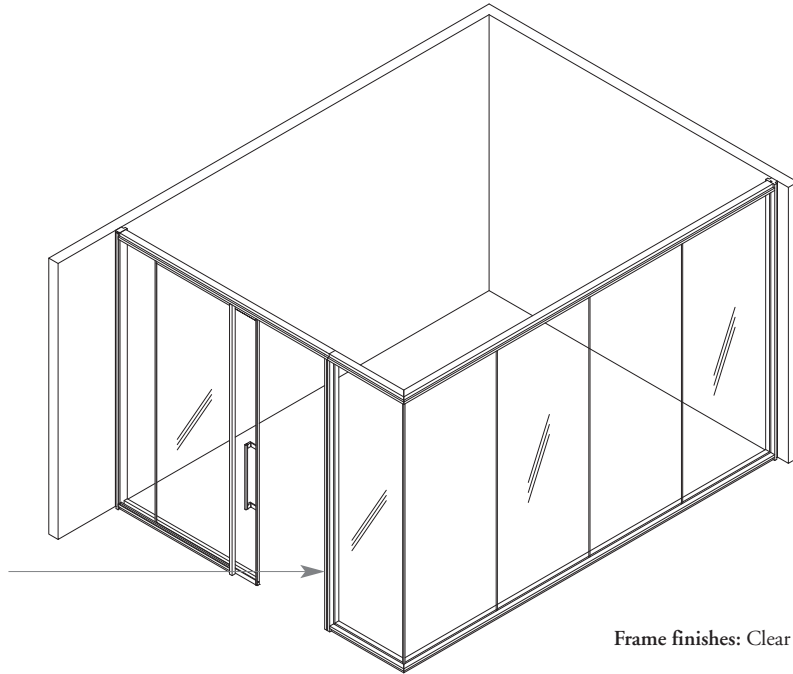

Wall Door Start
Single Centered
Glass (FWWDGS)

Frame finishes: Clear Anodized and Painted

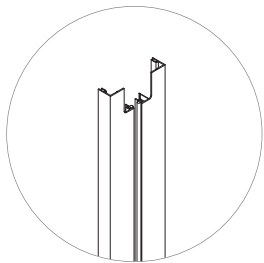

Wall Door Start Single Centered Glass (FWWDGS)

Allows for a single center glass monolithic fascia to connect to an adjacent pivot/hinge/sliding door.

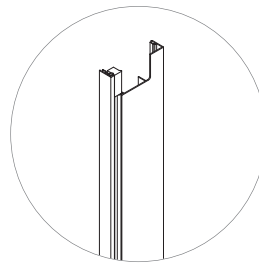

Wall Door Start Offset Glass (FWWDGO)

Allows for a single offset glass monolithic fascia to connect to an adjacent pivot/hinge/sliding door.

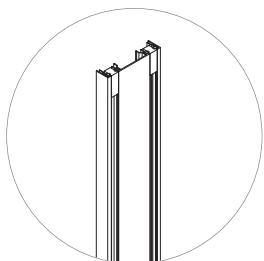

Wall Door Start Double Glass (FWWDGD)

Allows for a double glass monolithic fascia to connect to an adjacent pivot/hinge/sliding door.

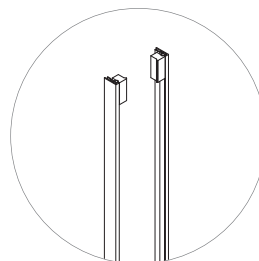

Wall Door Start Solid (FWWDSD)

Allows for a solid monolithic fascia to connect to an adjacent pivot/hinge/sliding door.

wall starts & wall ends

planning with wall door starts

The following outlines the applications for each wall door start.

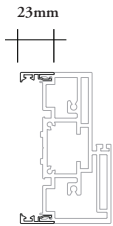

All wall door starts have a nominal depth of 23mm, Wall Door Start Solid (FWWDSD) shown

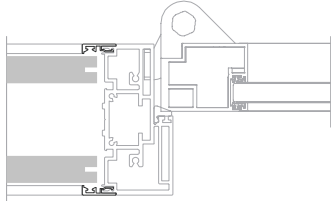

Wall Door Start Solid (FWWDSD)

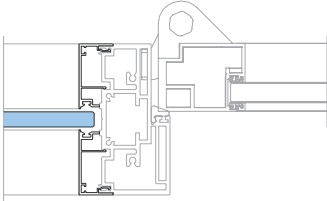

Wall Door Start Single Centered Glass (FWWDGS)

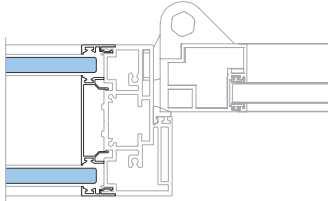

Wall Door Start Double Glass (FWWDGD)

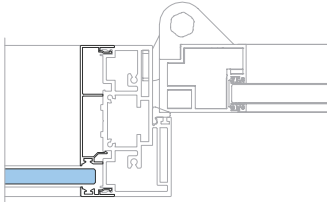

Wall Door Start Offset Glass (FWWDGO)

wall end basics

Focus offers a variety of wall ends that connect to glass and solid fascias and doors.

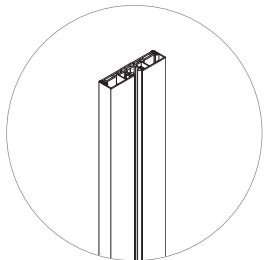
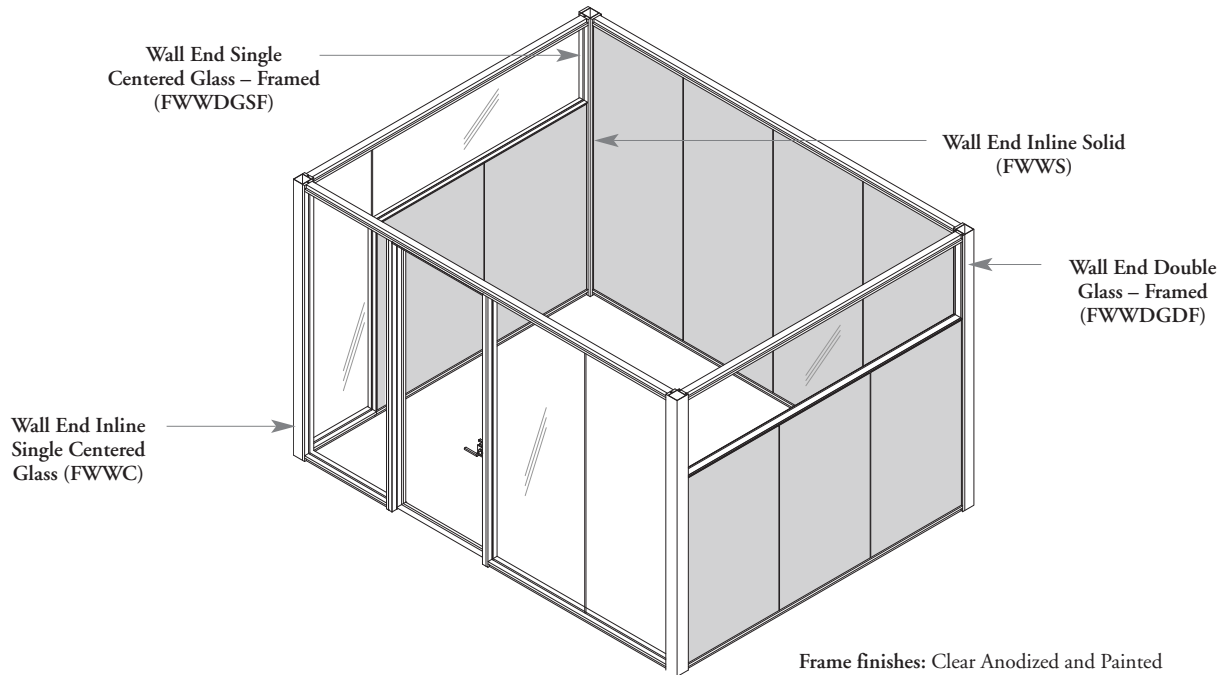

Wall End Inline Single Centered Glass (FWWC)
 • Wall end inline for monolithic single centered glass

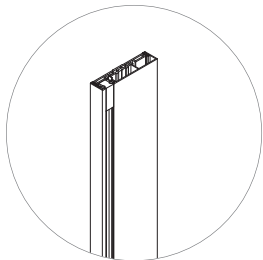

Wall End Inline Offset Glass (FWWO)
 • Wall end inline for monolithic offset glass

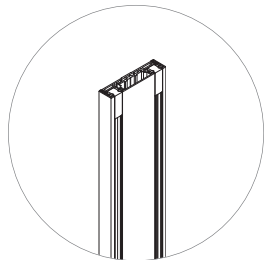

Wall End Inline Double Glass (FWWD)
 • Wall end inline for monolithic double glass

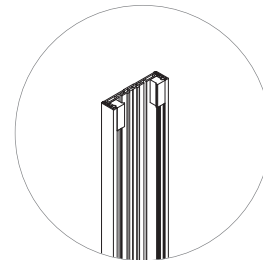

Wall End Inline Solid (FWWS)
 • Wall end inline for monolithic solid

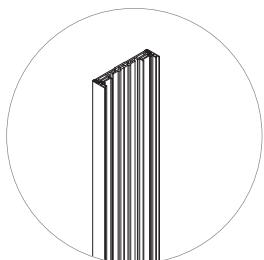

Wall End Inline Door (FWTID)
 • Wall end inline for pivot/hinged/sliding/doors

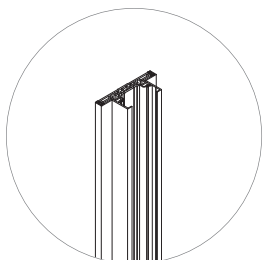

Wall End Inline Electrical (FWTIE)
 • Wall end inline for electrical filler panel

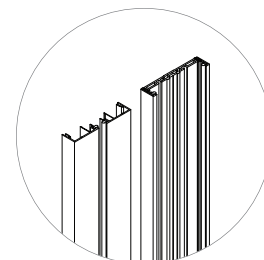

Wall End Single Centered Glass-Framed (FWWDGSF)
 • Wall end inline for single centered glass in a clerestory application

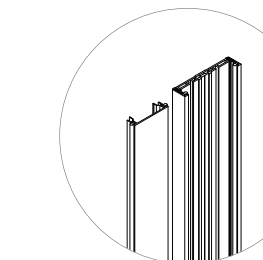

Wall End Double Glass - Framed (FWWDGDF)
 • Wall end inline for double glass in a clerestory application

wall starts & wall ends planning with wall ends

The following should be considered when planning with wall ends.

23mm

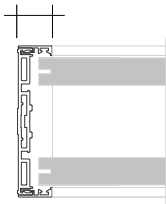

All wall ends have a nominal width of 23mm, Wall End Inline Solid (FWWS) shown, excluding the Wall End Inline Electrical (FWTIE) which has a nominal width of 12mm

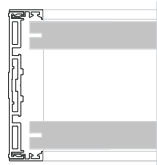

Wall End Inline Solid (FWWS)

Can be used with solid monolithic at wall ends

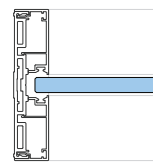

Wall End Inline Single Centered Glass (FWWC)

Can be used with center glass fascias at wall ends

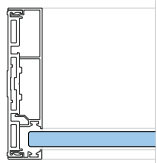

Wall End Inline Offset Glass (FWWO)

Can be used with offset glass fascias at wall ends

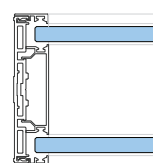

Wall End Inline Double Glass (FWWD)

Can be used with double glass fascias at wall ends

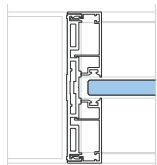

Wall End Single Centered Glass - Framed (FWWDGSE)

- Can be used with center glass clerestory at wall ends
- Corner Transition (FWTCD) must be specified in this application to add structural stability

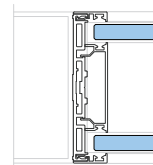

Wall End Double Glass - Framed (FWWDGDF)

- Can be used with double glass clerestory at wall ends
- Corner Transition (FWTCD) must be specified in this application to add structural stability

12mm

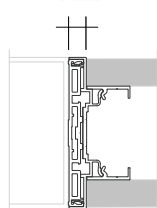

Wall End Inline Electrical (FWTIE)

- Can be used with electrical panel at wall ends
- Corner Transition (FWTCD) must be specified in this application

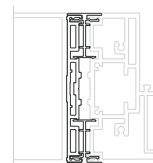

Wall End Inline Door (FWTID)

- Can be used with any pivot, hinge or sliding door frame
- Corner transition (FWTCD) must be specified in this application

planning with wall ends (continued)

Focus wall ends can be used together with corner transitions to create typical and non-typical planning solutions with glass, solid and drywall fascias.

Examples:

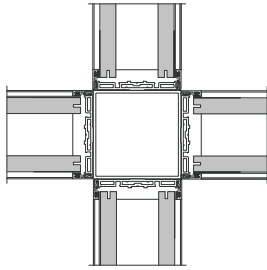

Four-way corner

- One Corner Transition (FWTCD)
- Four Wall End Inline Solid (FWWS)

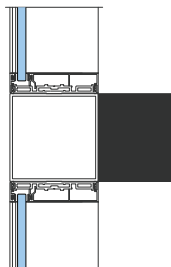

Three-way corner

- One Corner Transition (FWTCD)
- Two Wall End Inline Offset Glass (FWWO)
- No wall end is required in this location, the corner transition mounts directly to the drywall

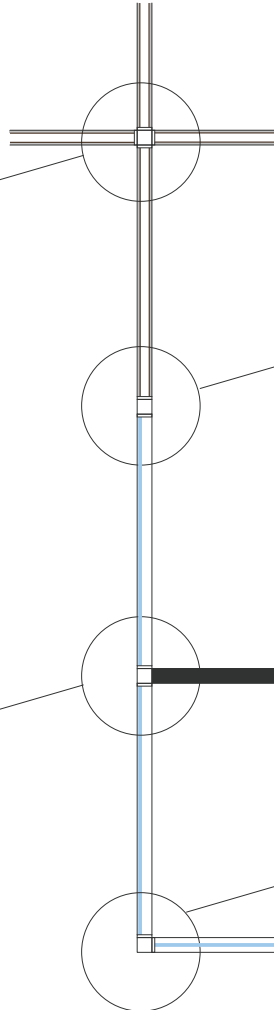

Inline

- One Corner Transition (FWTCD)
- One Wall End Inline Offset Glass (FWWO)
- One Wall End Inline Solid (FWWS)

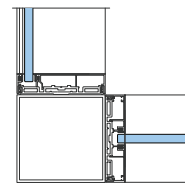

Two-way corner

- One Corner Transition (FWTCD)
- One Wall End Inline Offset Glass (FWWO)
- One Wall End Inline Centered Glass (FWWC)

planning with wall ends (continued)

construction

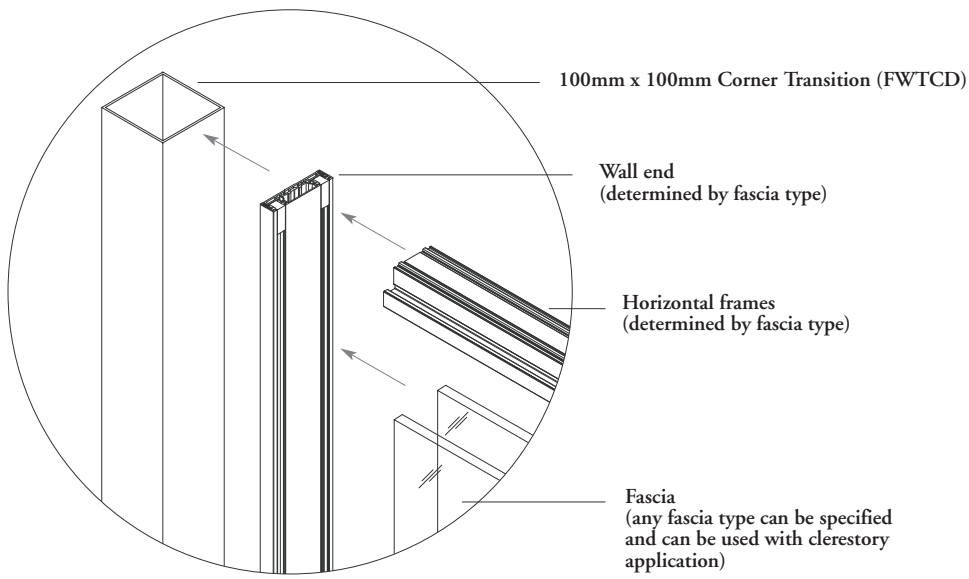

wall transitions

wall transitions

INLINE WALL TRANSITION BASICS	92
WALL TRANSITIONS FOR CLERESTORY BASICS	95
WALL TRANSITIONS CORNER BASICS	96
PLANNING WITH WALL TRANSITIONS	97

inline wall transition basics

Focus offers a variety of vertical wall transitions for inline connections of glass, solid, filler panels and doors.

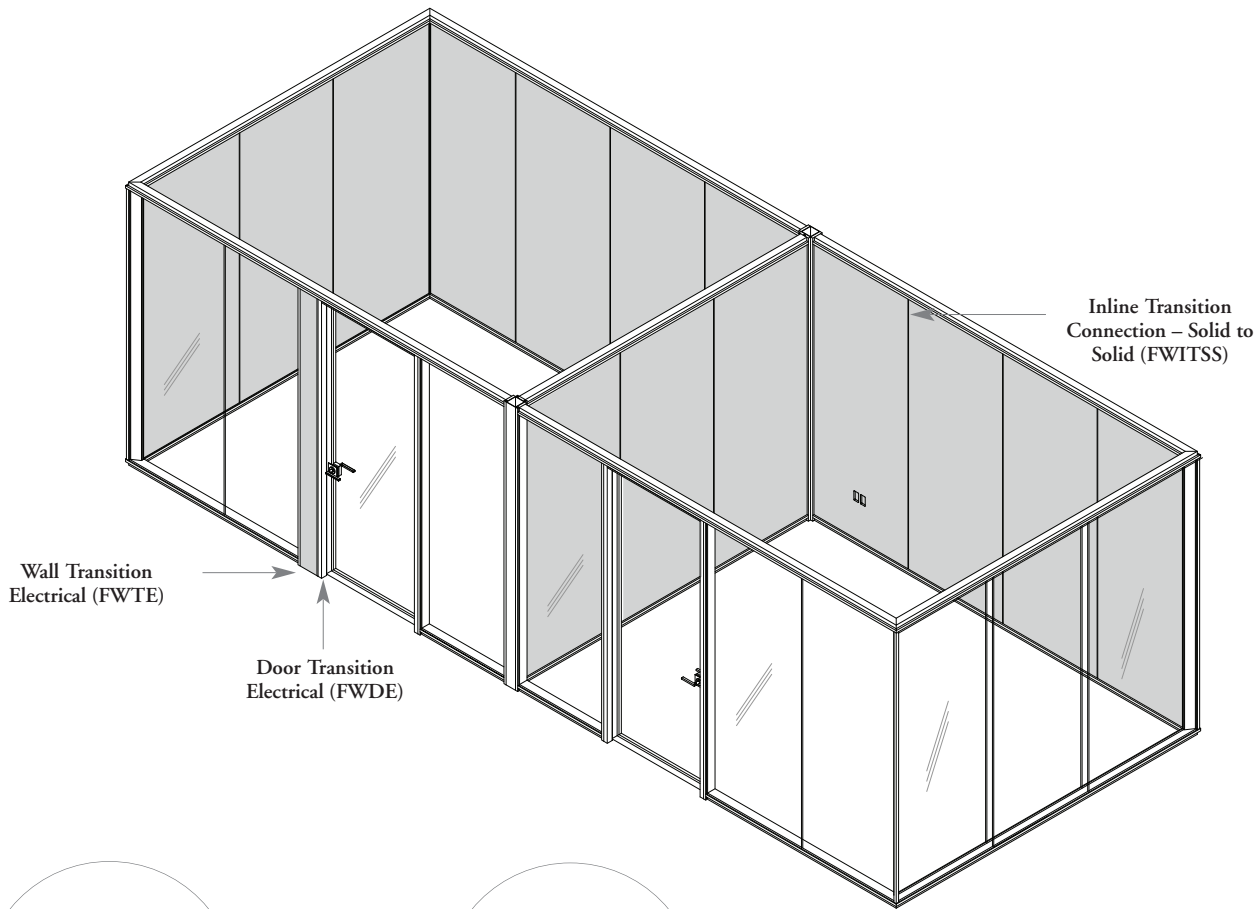

Frame finishes: Clear Anodized or Painted

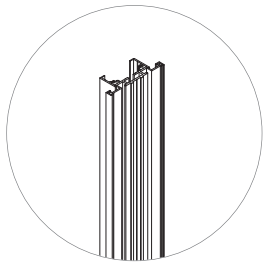

Wall Transition Electrical (FWTE)
Connects an electrical filler panel to monolithic partition/fascia in a straight run

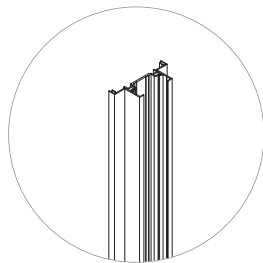

Door Transition Electrical (FWDE)
Connects an electrical filler panel adjacent to any pivot/hinged/barn door

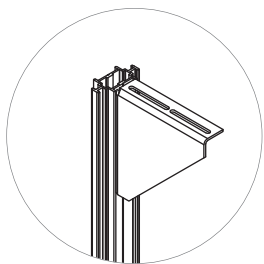

Inline Transition Connection - Solid to Solid (FWITSS)
Connects inline solid to solid monolithic partition/fascias in the same run

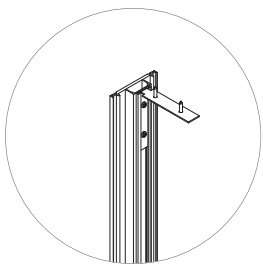

Inline Transition Connection - Solid to Double Glass (FWTISGD)
Connects inline solid fascias to double glass monolithic partition/fascias in the same run

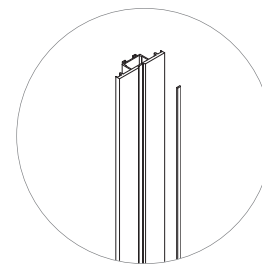

Inline Transition Connection - Solid to Single Glass (FWTISGS)
Connects inline solid to single center glass monolithic partition/fascias in the same run

inline wall transition basics (continued)

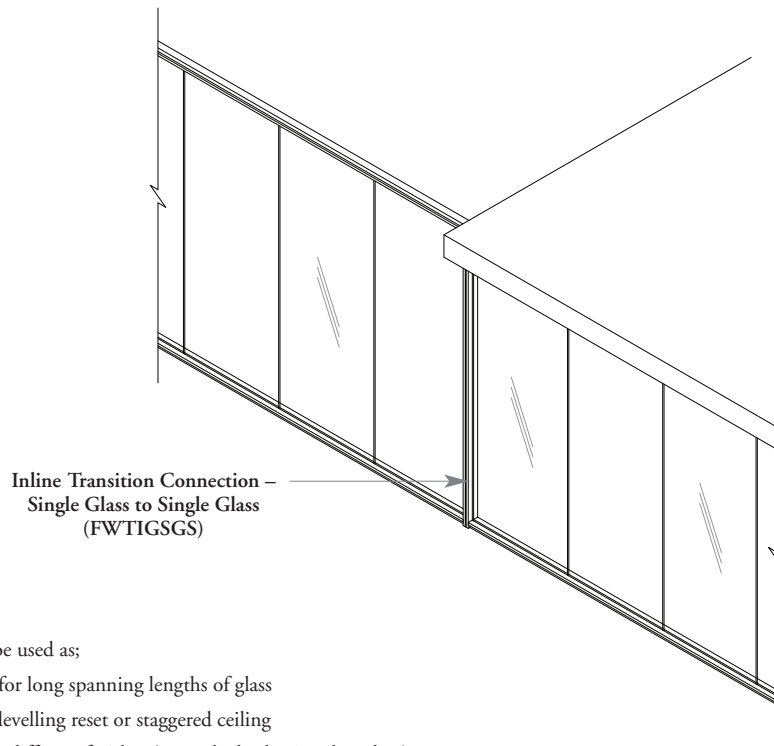

Inline transitions can be used as;

- A structural support for long spanning lengths of glass
- A wall run break for levelling reset or staggered ceiling
- A transition break for different finishes (example: backpainted to clear)
- Glass fascia transitions

Frame finishes: Clear Anodized and Painted

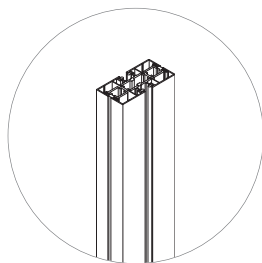

Inline Transition Connection – Single Glass to Single Glass (FWTIGSGS)

Creates a vertical transition break between an inline single center to single center glass monolithic partition

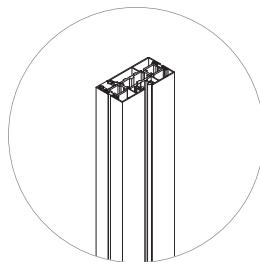

Inline Transition Connection – Single Centered Glass to Single Offset Glass (FWTIGSGO)

Creates a vertical transition break between an inline single center to single center glass monolithic partition

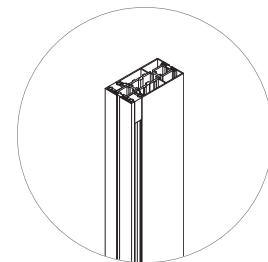

Inline Transition Connection – Offset Glass to Offset Glass (FWTIGOGO)

Creates a vertical transition break between an inline single center to single center glass monolithic partition

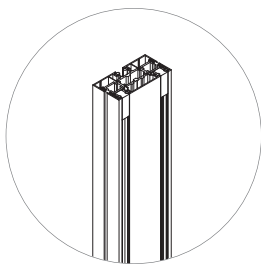

Inline Transition Connection – Double Glass to Single Glass (FWTIGDGS)

Creates a vertical transition break between an inline single center to single center glass monolithic partition

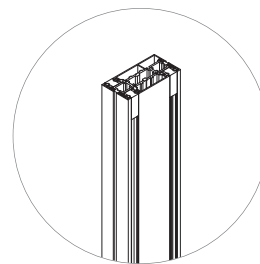

Inline Transition Connection – Double Glass to Offset Glass (FWTIGDGO)

Creates a vertical transition break between an inline single center to single center glass monolithic partition

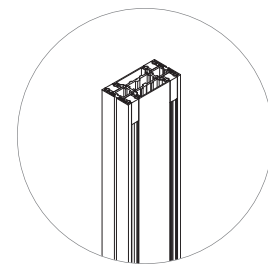

Inline Transition Connection – Double Glass to Double Glass (FWTIGDGD)

Creates a vertical transition break between an inline single center to single center glass monolithic partition

inline wall transition basics (continued)

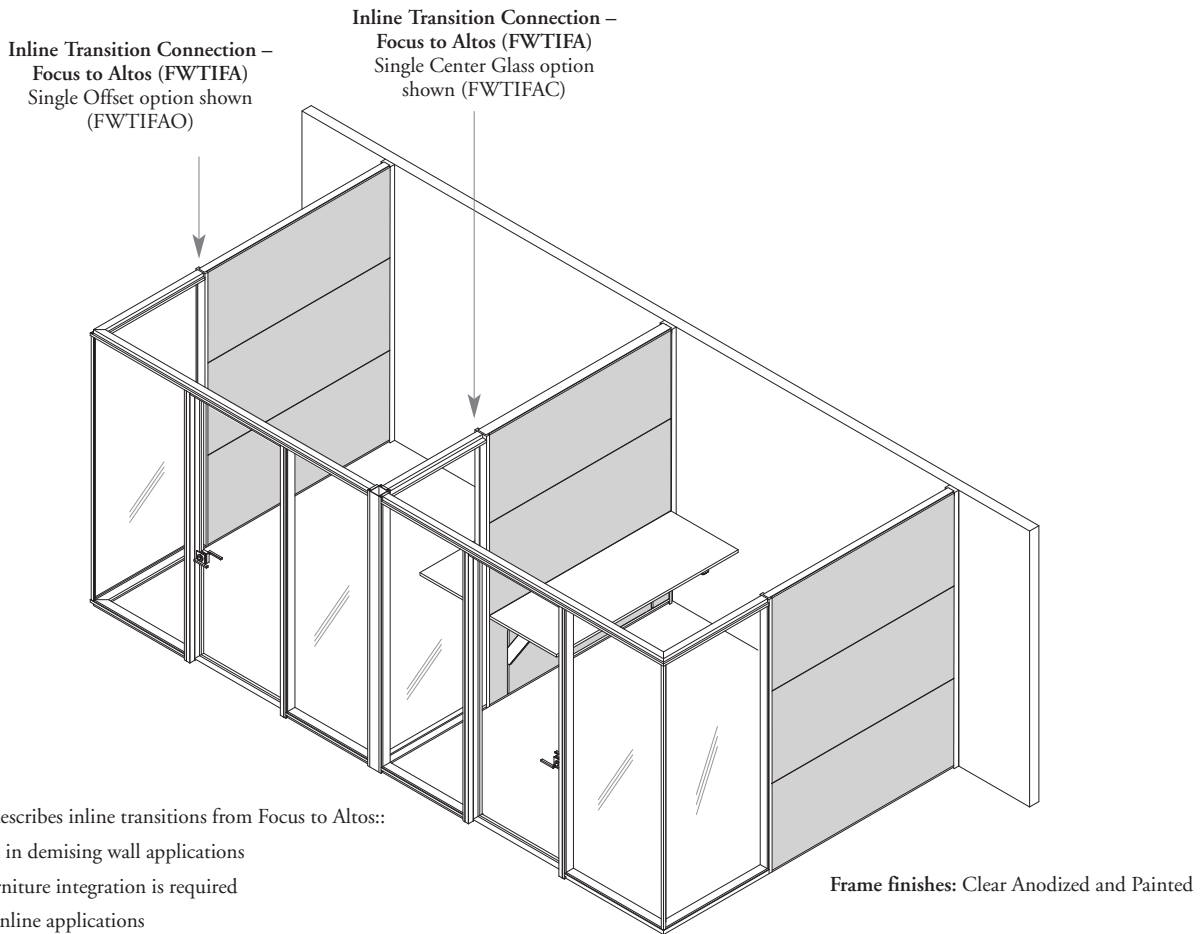

The following describes inline transitions from Focus to Altos:

- Primarily used in demising wall applications
- Ideal when furniture integration is required
- Only used in inline applications
- Focus side of transition must be monolithic glass (single centered, offset or double glazed)
- Altos side of transition can be planned with monolithic solid (portrait/landscape), clerestory or any door type if required

Frame finishes: Clear Anodized and Painted

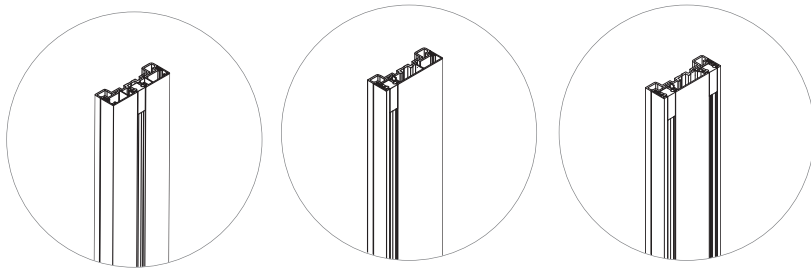

Single Center Glass
FWTIFAC (C)

Single Offset option
FWTIFAO (O)

Double Glass
FWTIFAO (D)

Inline Transition Connection – Focus to Altos (FWTIFAO)

Creates a vertical transition break between an inline Focus monolithic single centered, single offset and double glass partition to Altos

wall transitions for clerestory basics

Focus offers a variety of vertical wall transitions for connecting glass, solid, filler panels and doors in clerestory applications.

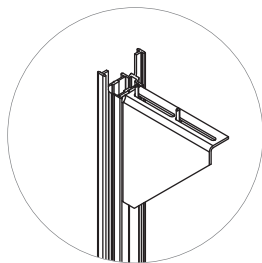
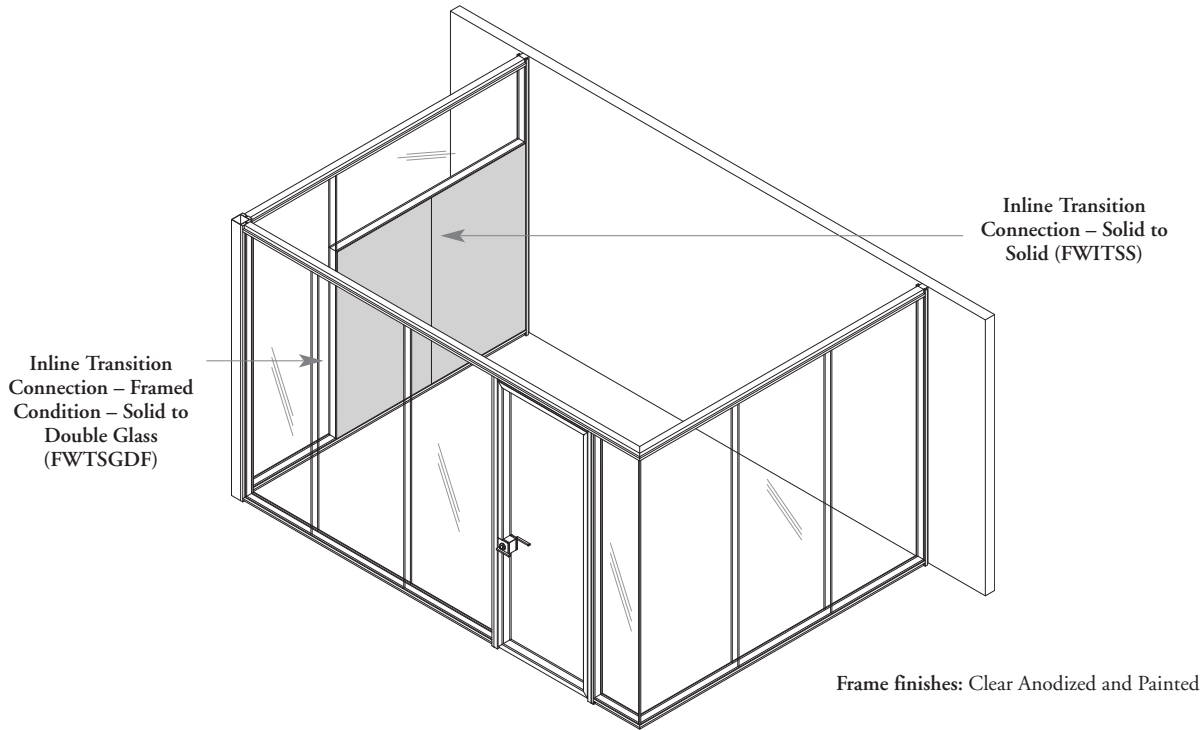

Inline Transition Connection – Framed Condition – Solid to Solid (FWITSSF)

- Connects inline solid to solid clerestory partition/fascias in the same run
- Creates a 3mm reveal between adjacent fascias

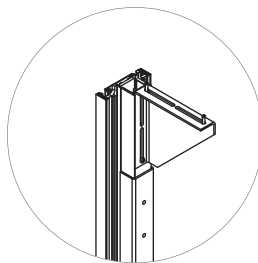

Inline Transition Connection – Framed Condition – Solid to Double Glass (FWTSGDF)

- Connects inline solid to double glass fascias when transitioning from a monolithic to clerestory partition/fascia in the same run

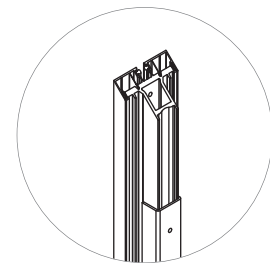

Inline Transition Connection – Framed Condition – Solid to Single Centered Glass (FWTSGSF)

- Connects inline solid to single center glass fascias when transitioning from a monolithic to clerestory partition/fascia in the same run

wall transitions corner basics

Focus offers a variety of corner transitions that can be used with or without wall ends to create a two-way, three-way and four-way connections.

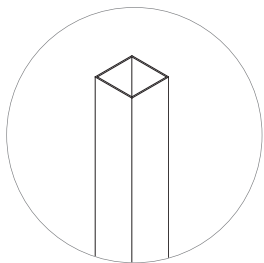
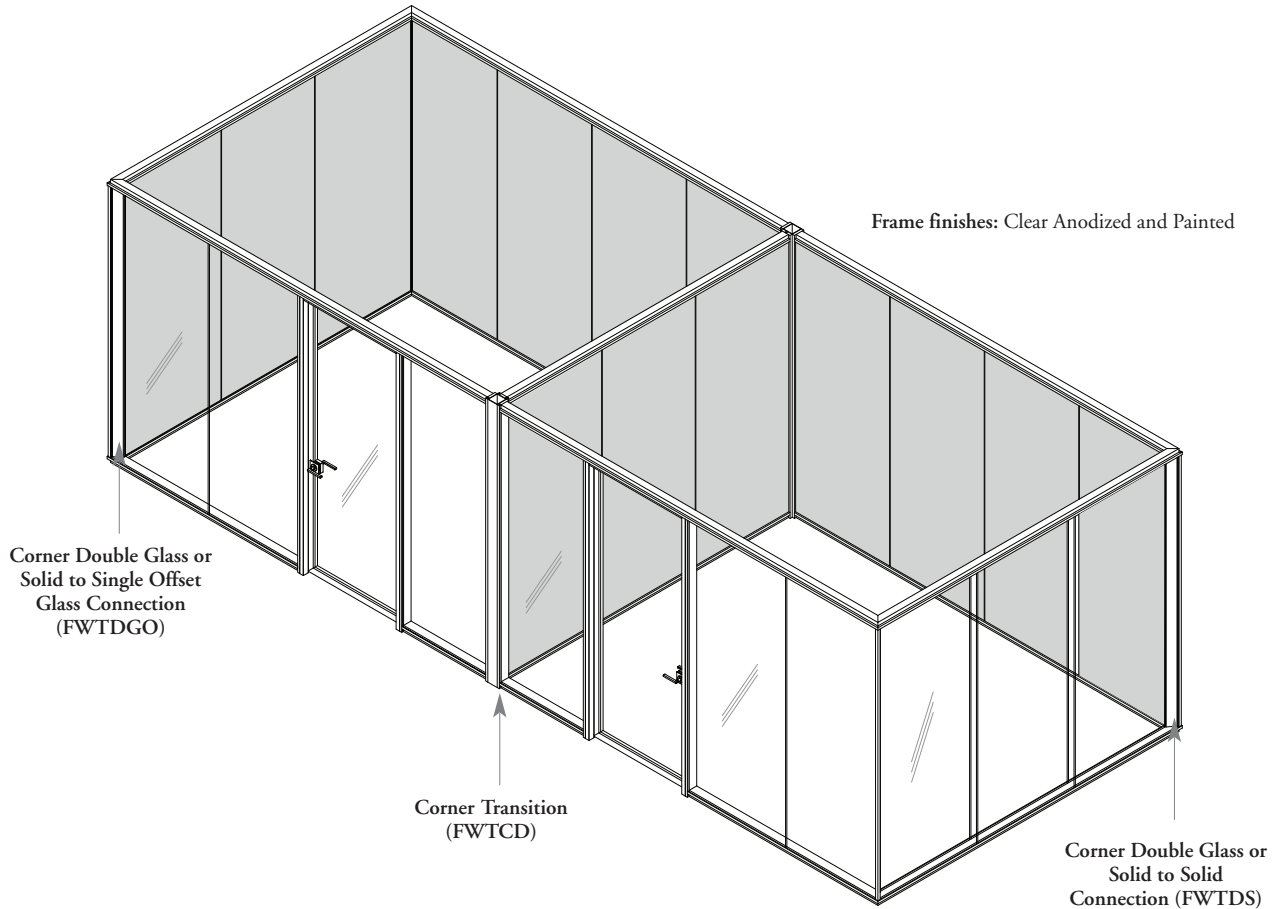

Corner Transition (FWTCD)
Can be combined with wall end runs to create unique inline, corner, three-way and four-way transitions

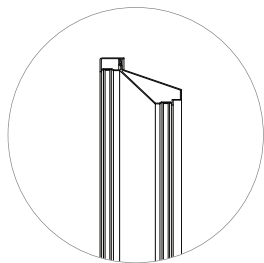

Corner Double Glass or Solid to Single Offset Glass Connection (FWTDGO)
Provides 90° corner transition from double glass or solid fascia to single offset glass fascia

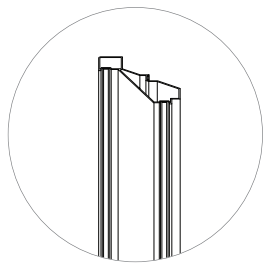

Corner Double Glass or Solid to Single Centered Glass Connection (FWTDGS)
Provides 90° corner transition from double glass or solid fascia to single centered glass fascia

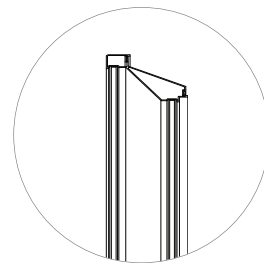

Corner Double Glass or Solid to Solid Connection (FWTDS)
Provides 90° corner transition from double glass or solid fascia to solid fascia

planning with wall transitions

The following demonstrates the features of each transition type.

solid to solid

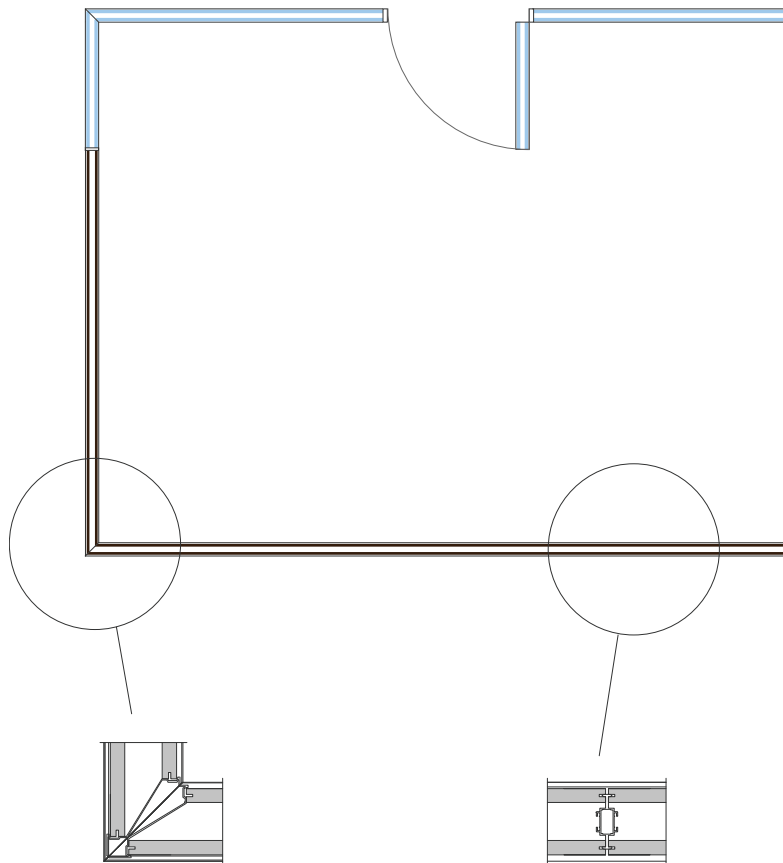

Corner Double Glass or Solid to Solid Connection (FWTDS)

- Provides 90° corner transition with a minimal vertical trim in the same run
- **Cannot** be used in clerestory applications

Inline Transition Connection – Solid to Solid (FWITSS)

- Connects inline solid to solid monolithic fascias in the same run
- Creates a 3mm reveal between adjacent fascias
- **Cannot** be used in clerestory applications

planning with wall transitions (continued)

solid to glass

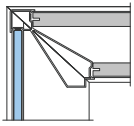

Corner Double Glass or Solid to Single Offset Glass Connection (FWTDGO)

- Provides 90° corner transition within minimal vertical trim in the same run
- Cannot be used in clerestory application

Corner Double Glass or Solid to Solid Connection (FWTDS)

- Provides 90° corner transition within minimal vertical trim in the same run
- Cannot be used with clerestory application

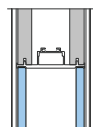
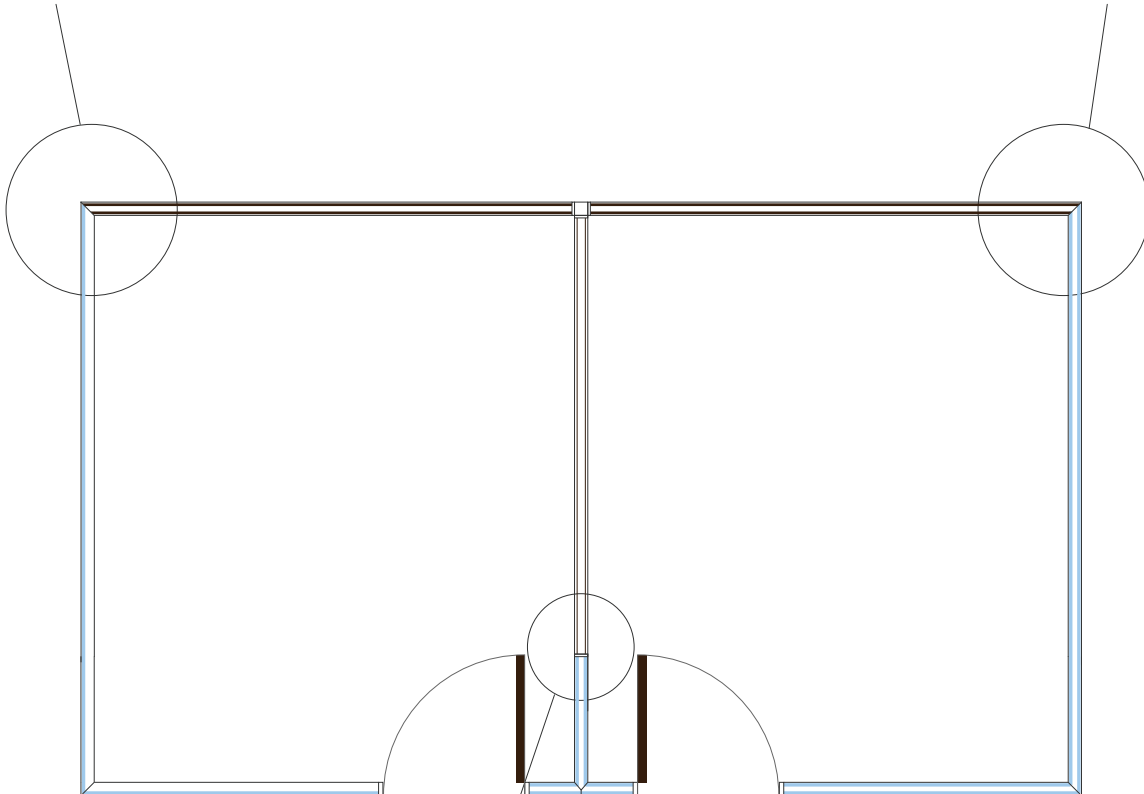
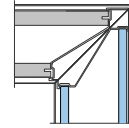

Inline Transition Connection – Solid to Double Glass (FWTISGD)

- Provides transition between solid and glass fascias with minimal trim (7mm thickness)
- Cannot be used in clerestory application

planning with wall transitions (continued)

glass to glass

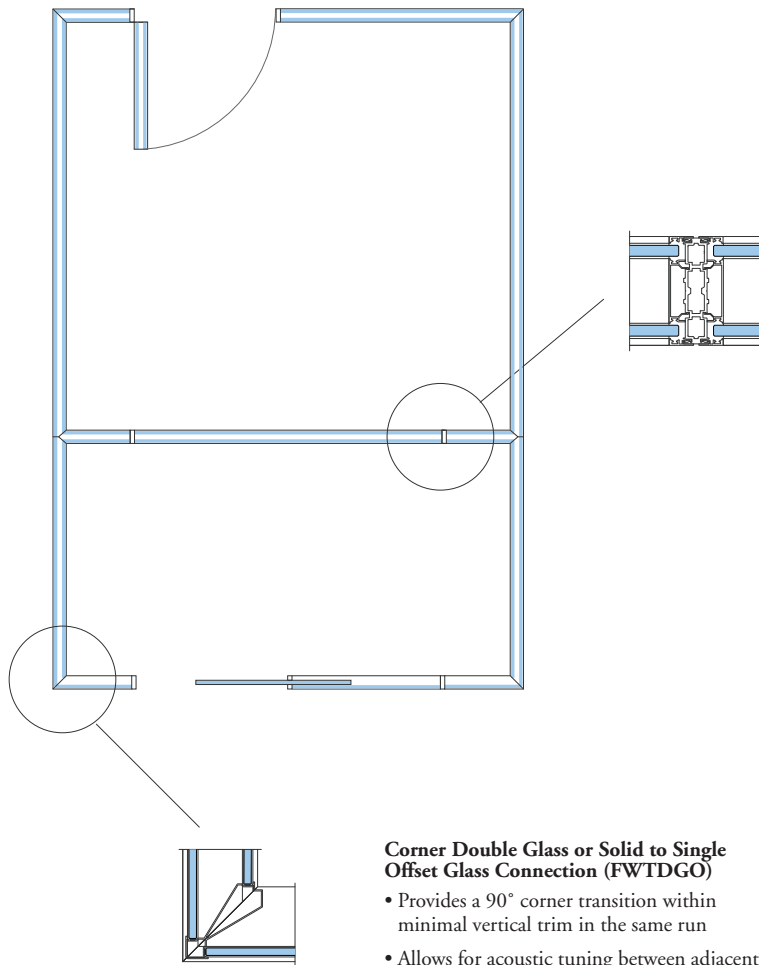

Inline Transition Connection – Double Glass to Double Glass (FWTIGDGD)

- Can be a structural support for long spanning lengths of glass
- Can be a wall run break for levelling reset
- Can be a transition break for different finishes (example backpainted to clear)

Corner Double Glass or Solid to Single Offset Glass Connection (FWTDGO)

- Provides a 90° corner transition within minimal vertical trim in the same run
- Allows for acoustic tuning between adjacent rooms

glass connectors

glass connectors

GLASS CONNECTOR BASICS102

PLANNING WITH GLASS CONNECTORS103

glass connector basics

Focus offers a variety of connectors for glass to glass connections that are available in aluminum, polycarbonate or tape options to provide a refined aesthetic.

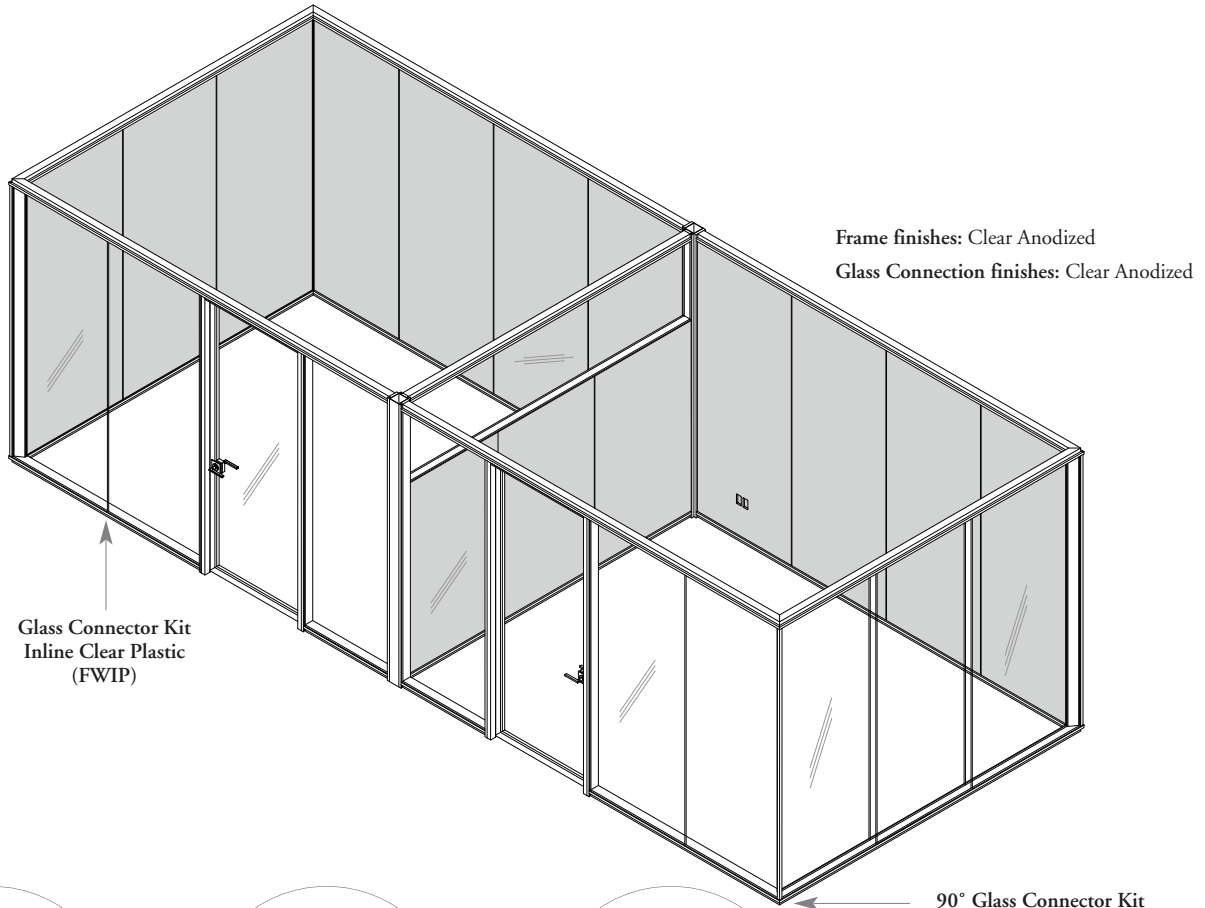

102

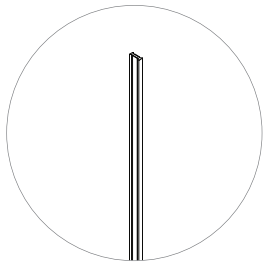

Glass Connector Kit Inline Clear Plastic (FWIP)
Available for 10mm and 12mm glass

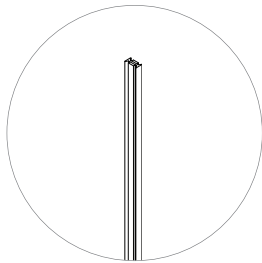

Glass Connector Kit Inline Aluminum (FWIA)
Available for 10mm and 12mm glass

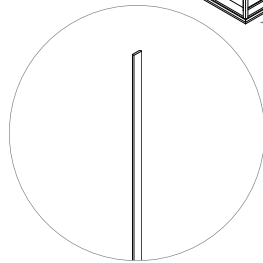

Glass Connector Kit Inline Tape (FWIT)
Available for 10mm and 12mm glass

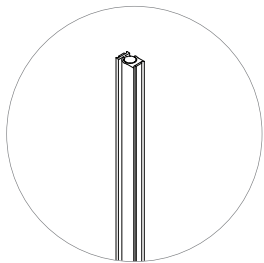

Glass Connector Kit Inline Variable Angle (FWIV)

- Allows for variable angle glass walls from 110°-170° (at 10° increments)
- Available in aluminum only

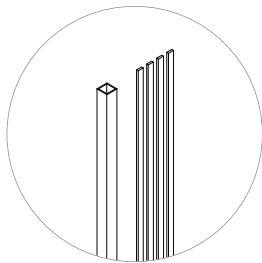

Glass Connector Kit Corner Aluminum Square (FWCA)
Available for 10mm and 12mm glass

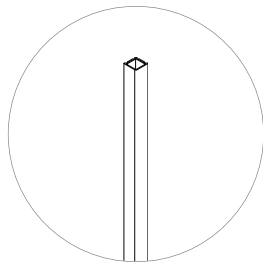

90° Glass Connector Kit (FWCN)

- Corner Connection types available include tape, plastic tube, and aluminum tube
- Available for 10mm and 12mm glass

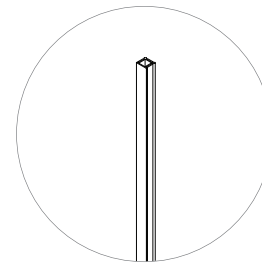

Three-Way Glass Connector Kit (FWCT)



- Corner Connection types available include tape, plastic tube, and aluminum tube
- Available for 10mm and 12mm glass

planning with glass connectors

The following outlines the options available for connecting glass fascias.

When specifying glass connections the following should be considered:

- There is only one inline connection type per run
- Corner and variable angle connections can be specified separately

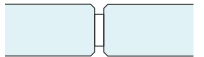
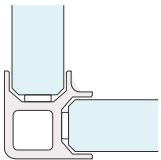
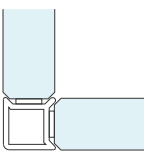
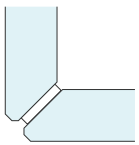
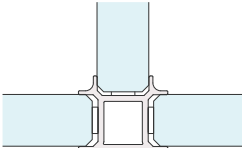
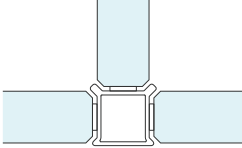
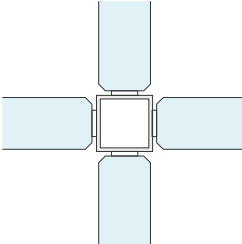
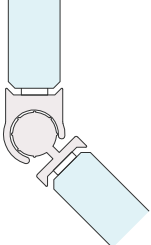
	Aluminum joined with tape	Polycarbonate joined with tape	Tape
Inline	 <p>Glass Connector Kit Inline Aluminum (FWIA)</p>	 <p>Glass Connector Kit Inline Clear Plastic (FWIP)</p>	 <p>Glass Connector Kit Inline Tape (FWIT)</p>
Two-way (90° corner)	 <p>90° Glass Connector Kit (FWCN)</p>	 <p>90° Glass Connector Kit (FWCN)</p>	 <p>90° Glass Connector Kit (FWCN)</p>
Three-way corner	 <p>Three-Way Glass Connector Kit (FWCT)</p>	 <p>Three-Way Glass Connector Kit (FWCT)</p>	
Four-way corner	 <p>Glass Connector Kit Corner Aluminum Square (FWCA)</p>		
Variable angle	 <p>Glass Connector Kit Inline Variable Angle (FWIV)</p>		

accessories & electrics

accessories & electrics

ACCESSORIES & ELECTRICS BASICS106

PLANNING WITH DOOR STOPS107

accessories & electrics basics

Focus offers a variety of accessories and electrical options for walls and doors.

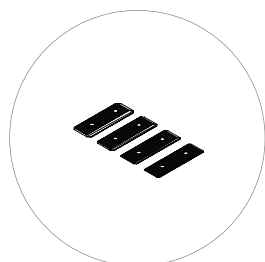
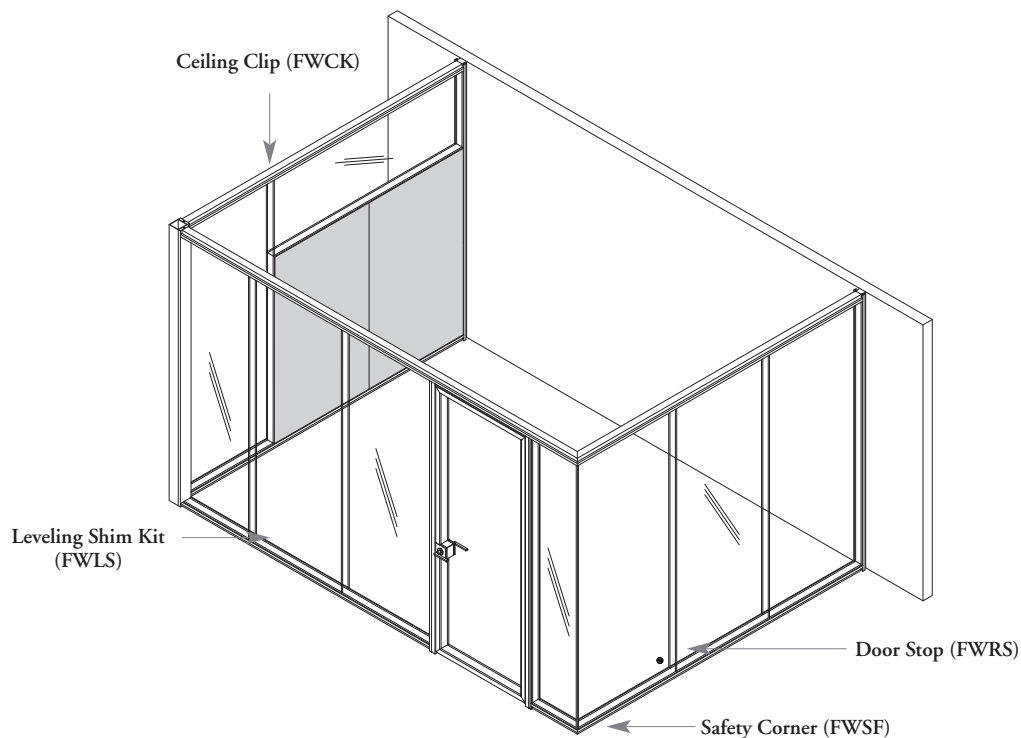

Leveling Shim Kit (FWLS)

- Adjustable plastic shims allow for micro-leveling under glass and solid fascias during installation

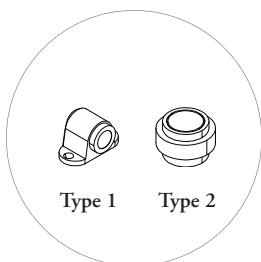

Door Stop (FWRS)

- Available in two door stop types circular and magnetic

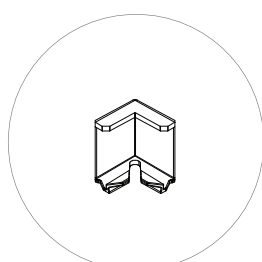

Safety Corner (FWSF)

- Clear plastic component can be snapped onto 90° mitred base track for added protection

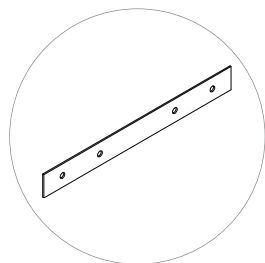

Splice Kit (FWSK)

- Connects two straight end frame sections together

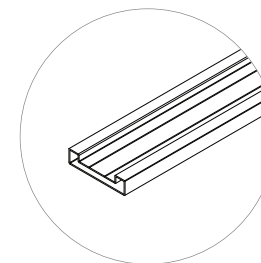

Ceiling Clip (FWCK)

- Mounts above a ceiling to allow for the mounting of ceiling frames
- Only available in 5' length

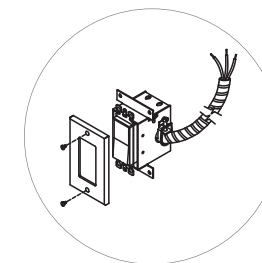

Light Module (FWLM)

- Mounts into a electrical filler panel
- Available Black or White
- Available 15 amp or 20 amp

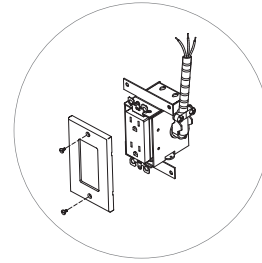



Receptacle Module (FWRM)

- Mounts into a electrical filler panel or solid fascia to provide power access
- Available receptacle type includes standard or isolated ground
- Available Black or White
- Available 15 amp or 20 amp

planning with door stops

The following outlines the features of Focus door stops.

		
Description	Magnetic door stop	Circular door stop
Teknion code	Door Stop, Type 2 (FWRS2)	Door Stop, Type 1 (FWRS1)
Finish	Stainless Steel (Grey Powder Coated Shims)	Stainless Steel (Black bumper)
Swing door compatibility	Framed pivot doors only	All pivot / hinged door types
Other features	Shim kit for leveling included Magnetic feature holds door open	

When planning with the door stop:

1. Whenever possible, place the stop close to nearby walls so it is not an obstacle to the path of travel
2. Ensure the stop prevents door hardware (example: pulls, levers) from making contact with nearby walls
3. Position the stop so it is close to the outer edge of the door leaf for maximum support in the open position

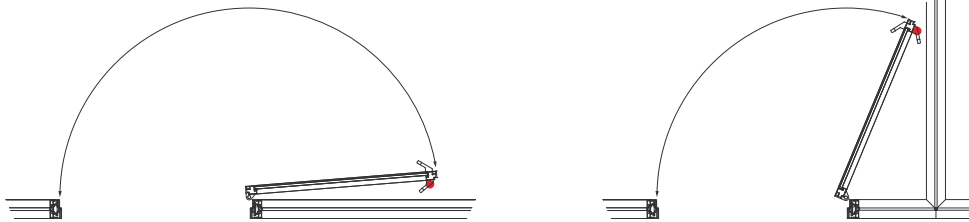

clerestory

clerestory

UNDERSTANDING CLERESTORY110

PLANNING WITH CLERESTORY111

understanding clerestory

A Focus clerestory module consists of solid and glass fascias combined with horizontal frames and trims.

Clerestory size restrictions:

- Ceiling height: 96" - 120"
- Minimum solid fascia height: 72"
- Glass width range: 12" - 118-1/16" for 10mm/12 mm
- Glass height range: 12" - 42" for 10mm, 12" - 44-12/16" for 12mm
- Maximum run width: 117-1/4"

solid to center glass

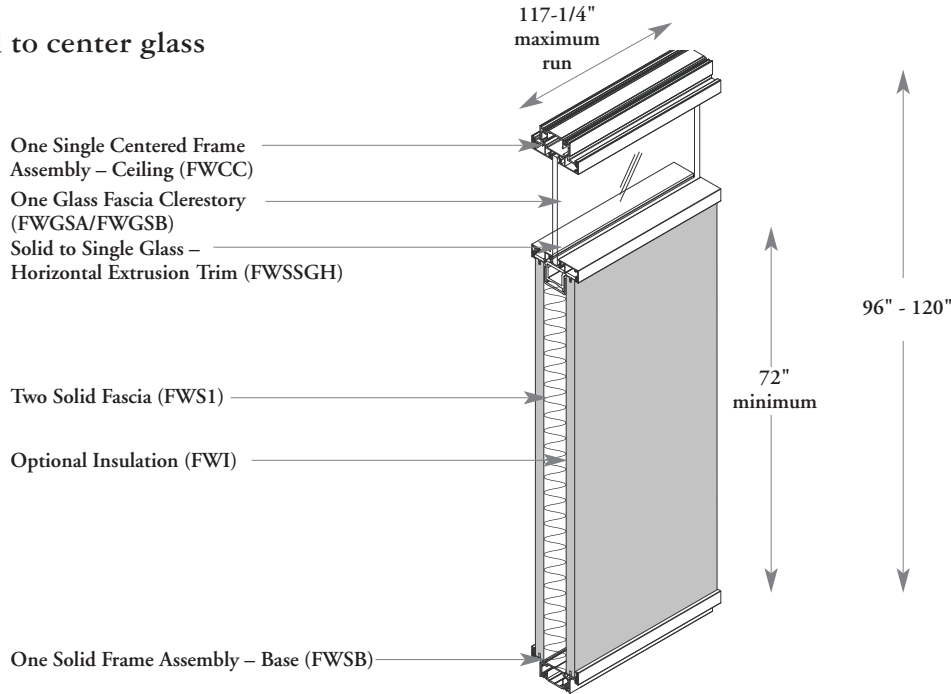

solid to double glass

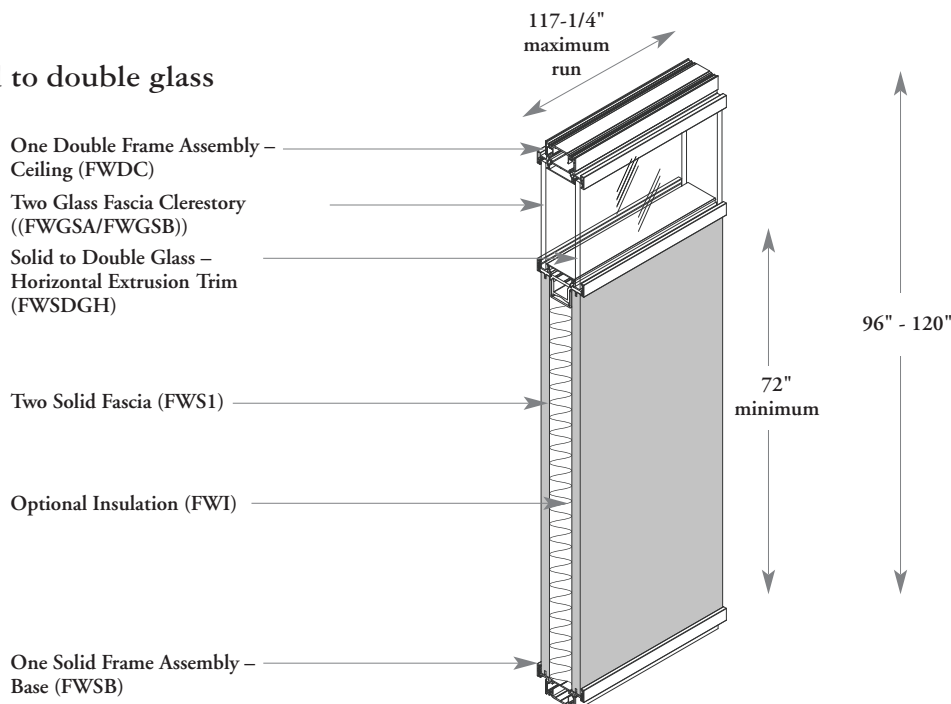

planning with clerestory

The following outlines the possible framing and connection conditions when planning with center and double glass clerestory.

wall start to clerestory

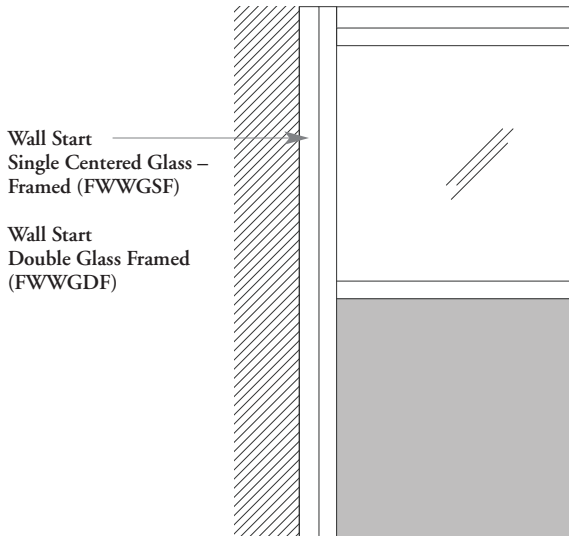

wall end to clerestory

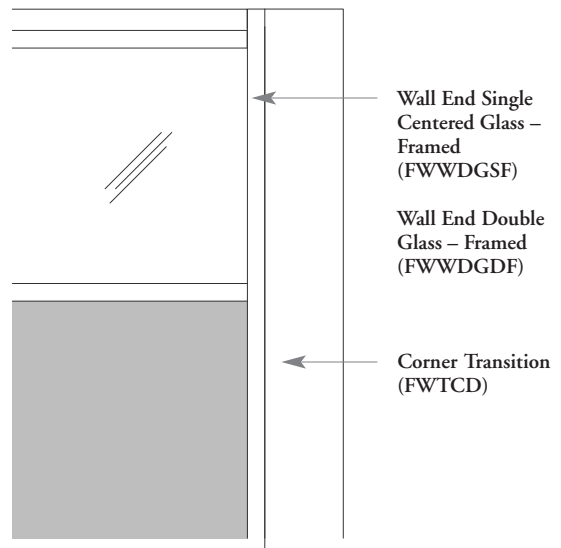

Monolithic glass fascia to clerestory (segmented type 2)

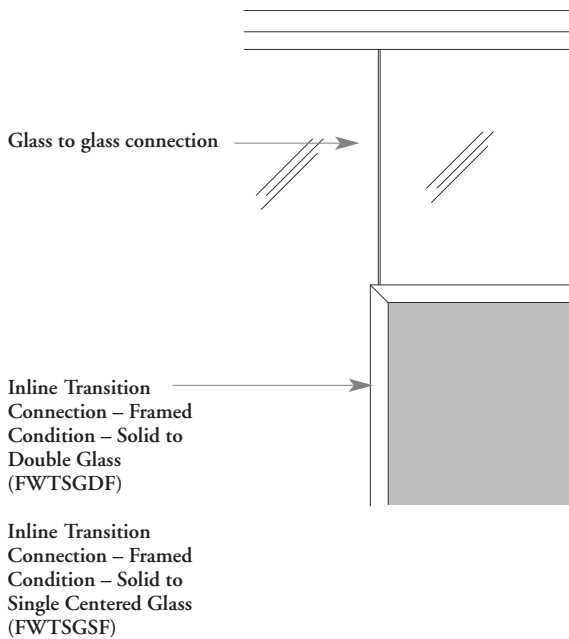

Monolithic solid fascia to clerestory (segmented type 1)

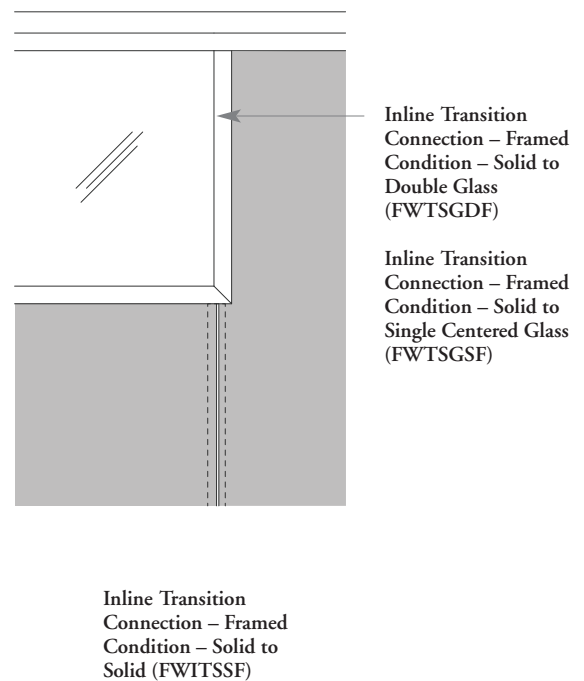

planning with clerestory (continued)

Three main types of elevation compositions are possible with clerestory. Each image represents a generic configuration based on the rules provided.

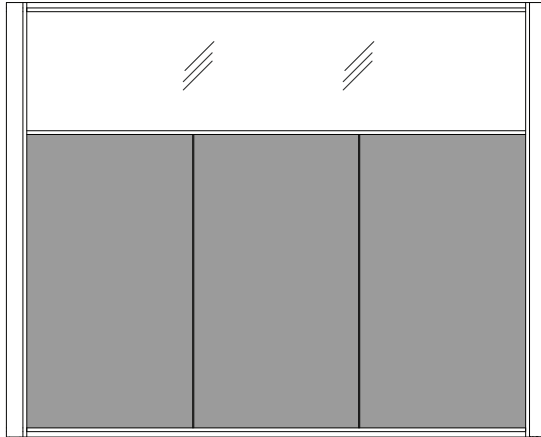

Clerestory

Solid

- Non-monolithic fascia only

Glass

- Single non-monolithic fascia only
- 10 or 12mm
- Tempered, Laminated or Low Iron
- Single Centered or Double Glazed

Vertical Framing

- Required on both sides (wall start or wall end)

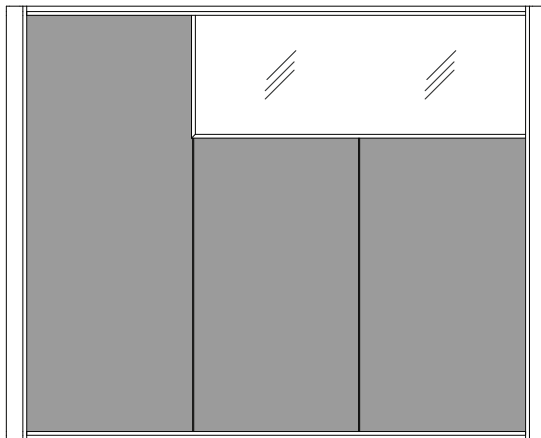

Segmented Type 1

Solid

- Single monolithic fascia on one side only

Glass

- Single non-monolithic fascia only
- 10 or 12mm
- Tempered, Laminated or Low Iron
- Single Centered or Double Glazed

Vertical Framing

- Required on both sides (wall start or wall end)

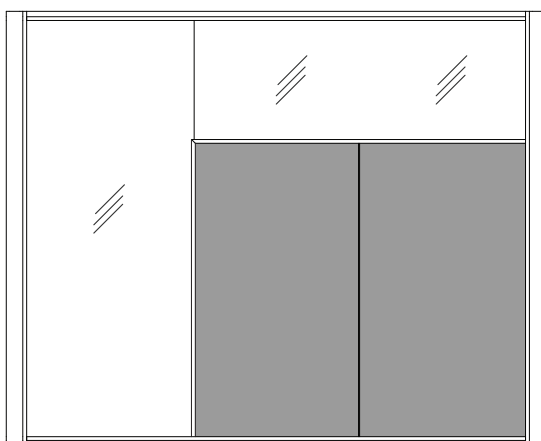

Segmented Type 2

Solid

- Non-monolithic fascia only

Glass

- Single monolithic fascia on one side only
- 12mm only
- Tempered or Low Iron Tempered
- Glass Connector Kit Inline Tape (FWIT) only
- Single Centered or Double Glazed

Vertical Framing

- Required on both sides (wall start or wall end)

planning with clerestory (continued)

The following restrictions apply when planning with clerestory.

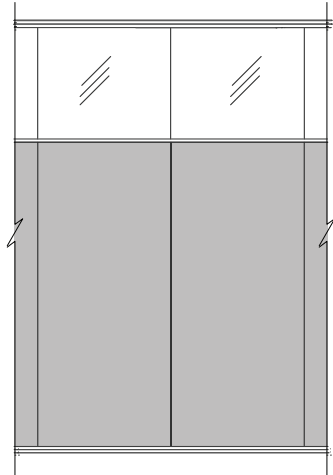

Glass **cannot** be segmented in clerestory applications.

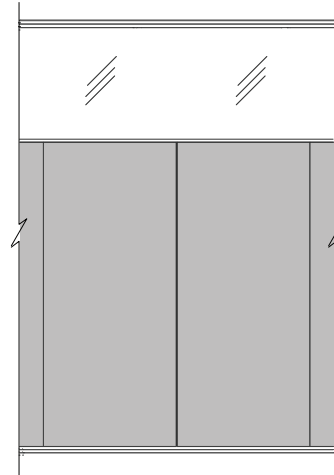

Glass must be full width in clerestory applications.

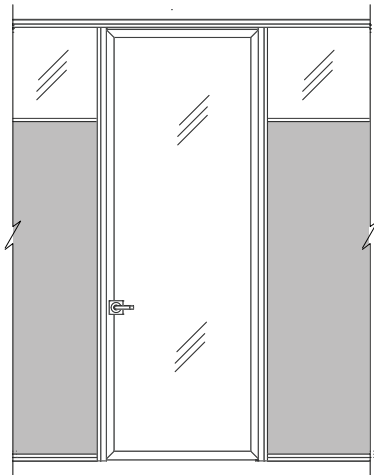

Clerestory **cannot** be used inline with a door.

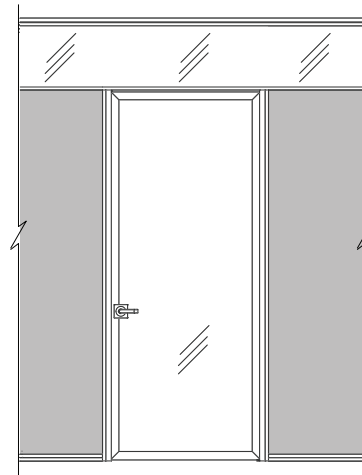

Clerestory **cannot** be used above a door.

teknion

www.teknion.com

IN CANADA:

1150 Flint Road
Toronto, Ontario
M3J 2J5 Canada
Tel 866.teknion
866.835.6466

IN THE USA:

350 Fellowship Road
Mt Laurel, New Jersey
08054 USA
Tel 877.teknion
877.835.6466

OTHER OFFICES LOCATED IN:

Europe, South and Central America
Middle East, Asia and Russia
For regional contact information
go to www.teknion.com

CAN/US/INT II-26

©Teknion 2018

®, ™ trade marks of Teknion
Corporation and/or its subsidiaries or
licensed to it. Patents may be pending.

Some products may not be available in
all markets. Contact your local
Teknion Representative for availability.

NOVI8-FOC-AG