



Architect: Manuelle Gautrand | Photography: Vincent Fillon

GEODE

CREATIVE CURTAIN WALL







GEODE, a comprehensive range of curtain walling

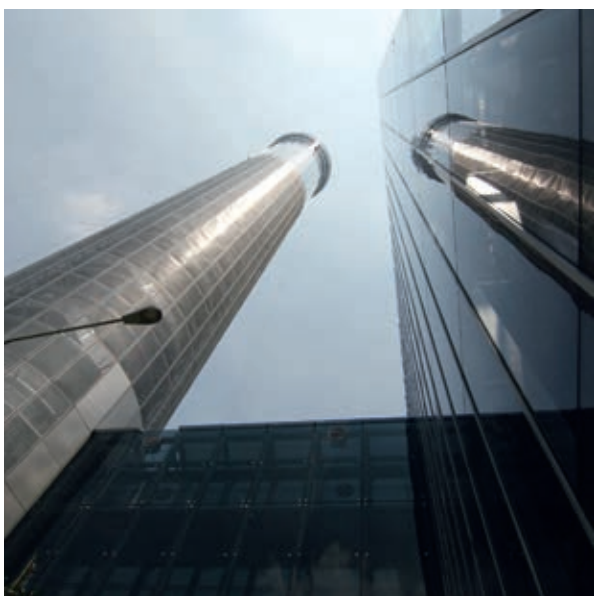

DR Technal

GEODE is a comprehensive range of curtain walling offering designers high thermal performance to meet even the most demanding building standards, and a wide range of aesthetic options based on a single system.

The variety of curtain walling applications, made possible thanks to the diversity of mullions and transoms, enables designers to vary the external appearance of the building whilst benefitting from the design and installation options of a fully integrated system.

When aesthetics meet functionality

The GEODE system successfully combines the creative and visual demands of architects with the functional needs of businessmen, developers and occupants, by simplifying the technical aspects as well as the manufacturing and the installation processes to guarantee optimal quality and profitability.

The designers also benefit from homogenous lines and interfaces for the same project, whether this is full-height, frame aspect or fully glazed curtain walling or features a beaded frame or roof lights.



Excellence in façade design

The GEODE range offers all the inherent qualities of aluminium: aesthetics, durability and reduced maintenance, and combines innovative technology and construction characteristics with advanced manufacturing techniques for a high quality installation with long-lasting performance.

This system is the result of a current development programme produced by Technal, and has been rigorously tested in accordance with European standards for wind resistance and water and air tightness.



GEODE VISIBLE GRID



Glazing infill: 6 mm to 42 mm.
Façade: flat or faceted up to 20°.
Concealed opening vent: projecting top-hung, parallel, open-in, tilt-turn, emergency access.

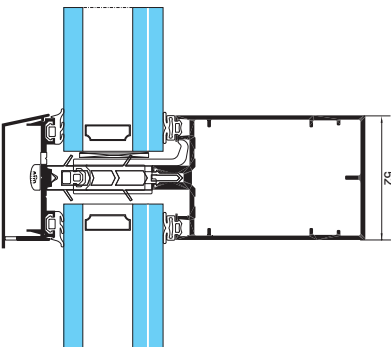

Options:
 - GEODE Acoustic
 - GEODE 62 for large glass panels
 - GEODE single glazing from 6 to 11 mm

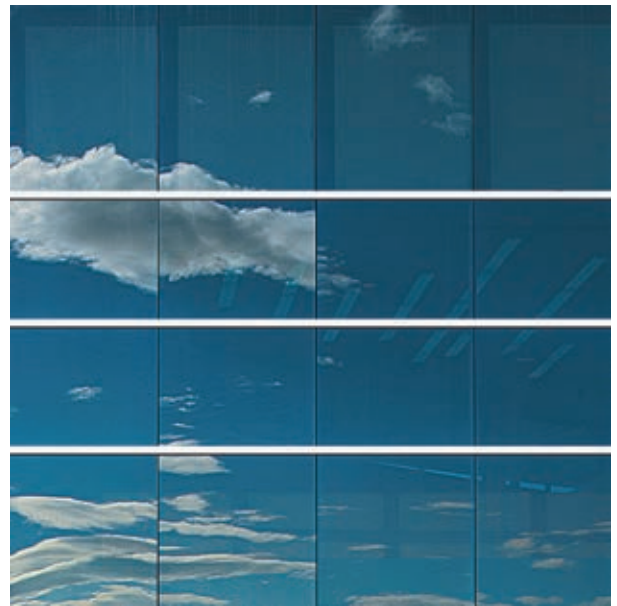

GEODE HORIZONTAL TRAME



Glazing infill: 6 mm to 42 mm.
Façade: flat or faceted up to 20°.
Concealed opening vent: projecting top-hung, parallel, open-in, tilt-turn, emergency access.

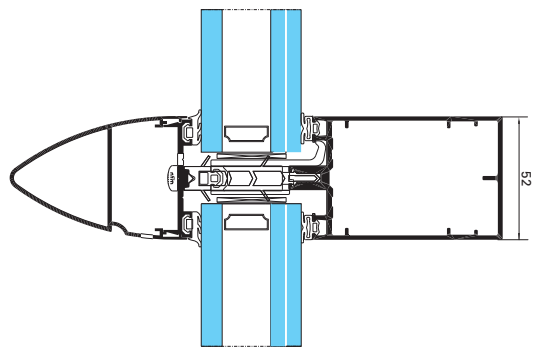

Options:
 - GEODE Acoustic
 - GEODE 62 for large glass panels
 - GEODE single glazing from 6 to 11 mm

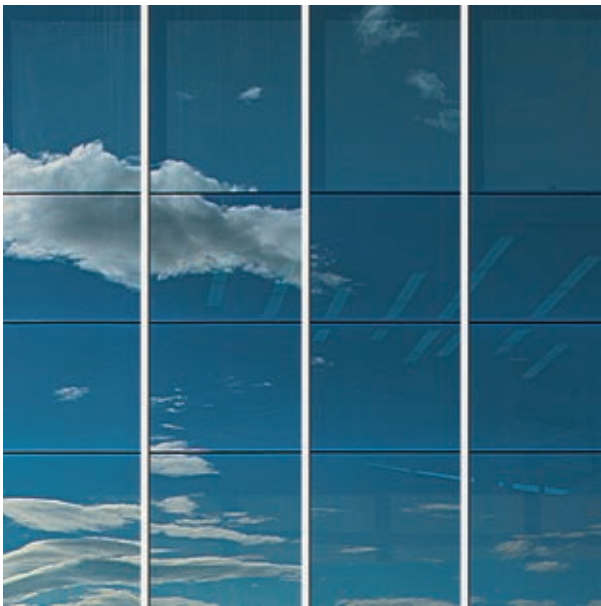

GEODE VERTICAL TRAME



Glazing infill: 6 mm to 32 mm.

Façade: Flat

Concealed opening vent: projecting top-hung, open-in, tilt-turn, emergency access.

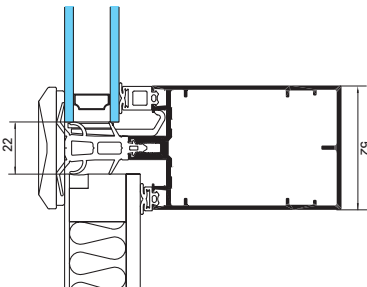

Options:
- GEODE single glazing from 6 to 11 mm



GEODE FRAME ASPECT

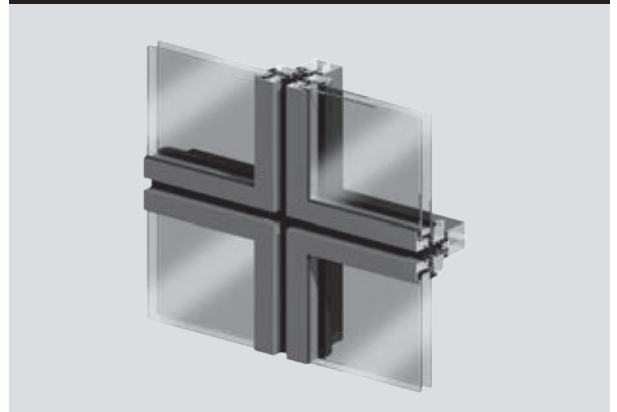

Glazing infill: 6 mm to 32 mm.

Façade: flat or faceted up to 2°.

Concealed opening vent: projecting top-hung, open-in, tilt-turn, emergency access.

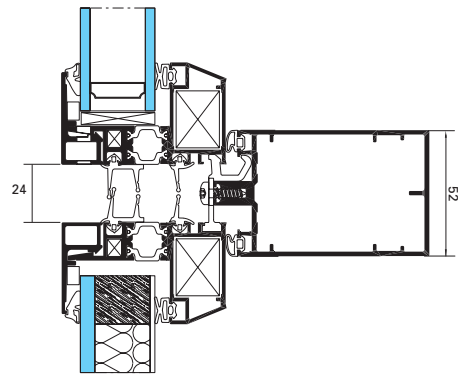

CONTENTS

| | |
|---------------------------------------|----|
| GEODE "TRAME" ASPECT | 10 |
| - VISIBLE GRID | 12 |
| - HORIZONTAL OR VERTICAL TRAME ASPECT | 14 |
| OPTIONS: | |
| - GEODE ACOUSTIC | 16 |
| - GEODE 62 | 18 |
| - GEODE SINGLE GLAZING | 20 |

| | |
|--------------------|----|
| GEODE FRAME ASPECT | 22 |
|--------------------|----|

| | |
|------------------------------------|----|
| GEODE ALL GLASS ASPECT | 26 |
| - MECHANICAL STRUCTURAL GLAZING | 28 |
| - STRUCTURAL SEALANT GLAZING (SSG) | 30 |

| | |
|-------------------|----|
| GEODE ROOF LIGHTS | 32 |
|-------------------|----|

| | |
|--------------|----|
| PERFORMANCES | 34 |
|--------------|----|

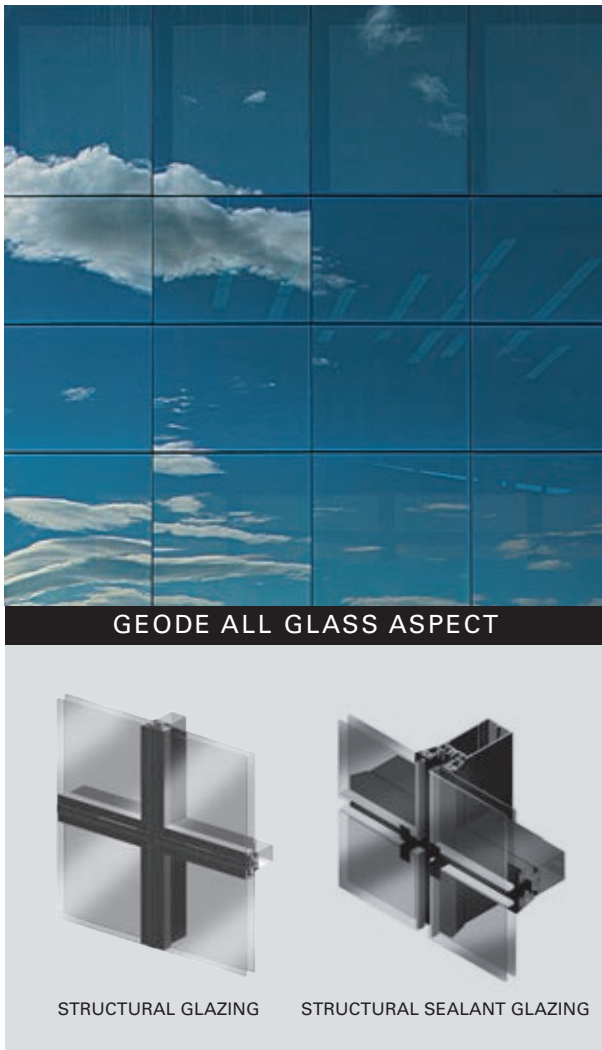

Glazing infill: SSG type 6 mm, 23 mm, 31 mm or mechanical structural glazing from 36 to 42mm.

Façade: flat or faceted up to 10° (depending on the technology used).

Concealed opening frame: SSG type: top-hung, open-in or tilt-turn, emergency access. SG type: top-hung or parallel.

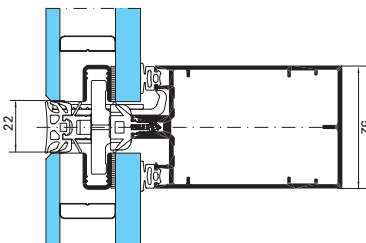

MECHANICAL
STRUCTURAL
GLAZING

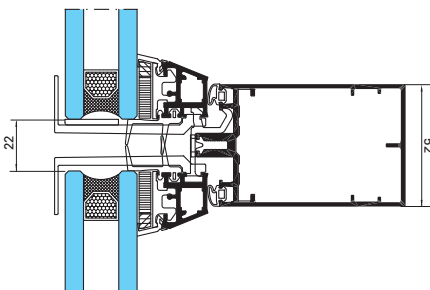

STRUCTURAL
SEALANT
GLAZING



Key features and innovations

- **Visual consistency.** Unique aluminium structure for all external appearances. The discreet and consistent 52 mm for the mullions and transoms give a uniform appearance to the entire GEODE range.
- **Thermal efficiency.** The structure's integrated thermal break and the possibility of using the most high performance glazing means that we can attain the lowest Ucw coefficients. Energy consumption for heating, lighting, ventilation and air-conditioning is reduced.
- **Technically advanced frame system.** High-quality components for long-term durability.
- **Intelligent design.** Designed for high-quality manufacturing and installation.
- **Meeting the requirements of each individual project.** We offer a selection of mullions up to 260 mm for structural elements and design flexibility to guarantee cost-effectiveness.
- **Complete system compatibility.** SOLEAL thermal break windows or doors or TOPAZE traditional windows and doors, as well as TITANE intensive use doors can all be used with GEODE curtain walling for a solution that is tailored to each project.
- **Concealed opening vents.** These opening frame solutions, which preserve the external appearance of the facade, can be used in multiple open-in or open-out applications.
- **Design details.** A wide range of external caps for greater aesthetic choice.
- **Choice of infills.** The system can be used with glass, insulated panels and other types of opaque panels.

Construction

- **Solid construction.** The mullions and transoms are square cut and assembled using a combination of factory-fitted cast face-fixed junction spigots and concealed anti-rotation spigots, or by transom blocks. This solid and easy to build design offers greater precision and stability.
- **High-quality design.** The specially designed fittings used for combining mullions/transoms ensure high-quality connections.
- **Cost-effectiveness.** All machining operations can be completed using manufacturing tools in order to reduce manufacturing time and costs, and lead to a constant level of quality.

Thermal performance and weather tightness

- **Increased resistance to climatic conditions.** Fully injectable, the mullion/transom assembly system using fittings ensures the precise and controlled injection of the sealing product to guarantee weather tightness. In each drainage zone, EPDM caps, positioned between the insulating spacer and the pressure plates, prevent the infiltration of water and additional sealing putty.
- **Effective drainage.** A secondary drainage system on the mullions enhances the weather tightness and quality. The system is drained by zone. The pressure is equalised to ensure optimum performance and effective drainage in the most demanding environments.





GEODE "Trame" aspects



GEODE “Trame” aspects

Visible grid

Flat or faceted façades.

Glazing available from 6 mm to 32 mm for flat or faceted curtain wall up to 20°.

Common structure with 52 mm-thick profiles.

Range of structural members from 4.53 cm⁴ to 2133 cm⁴ to meet the needs of each project.

Optimised distribution of loads

to prevent the deformation of the transoms and to allow the use of heavy and large glass panels. Maximum weight of 300 kg (assembled using a connector and anti-rotation spigot).

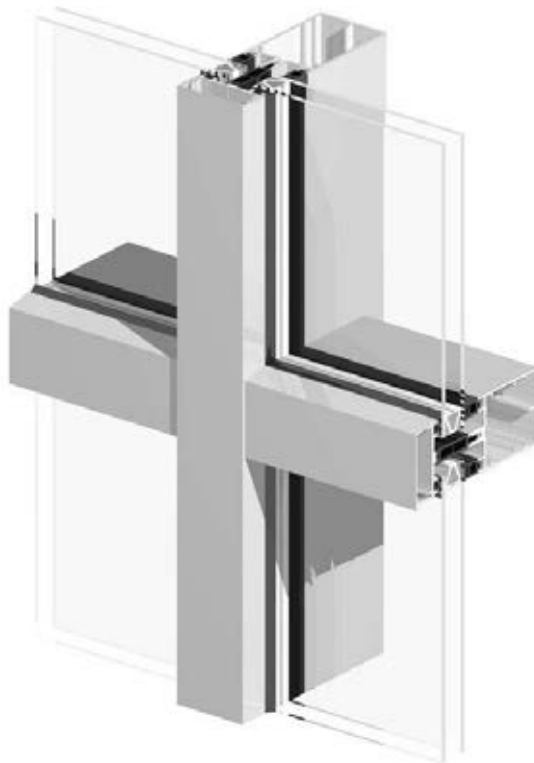

Additional acoustic and thermal performance.

GEODE Acoustic is an additional option for the GEODE Grid aspect system developed for projects requiring enhanced acoustic and thermal performances with glazing up to 42 mm.

Large dimension glazing.

GEODE 62 is an option that uses mullions and transoms from a 62 mm module to increase the dimensions of the glazing and thus intensify the light.

Design. Choice of aluminium caps to highlight the external design of the façade.

Concealed opening vents.

The projecting top-hung, parallel, tilt-turn or emergency access opening vents provide natural ventilation whilst maintaining the aesthetic lines whatever the appearance of the external façade.

Choice of gaskets. Available as large vulcanised corner or linear pieces depending on the project's requirements.

Infills held in place with a continuous aluminium pressure plate or a specific polyamide pressure plate with fitted vulcanised gaskets.

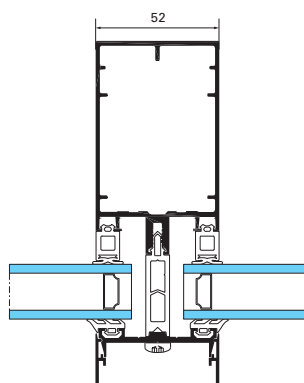

Fixed visible grid

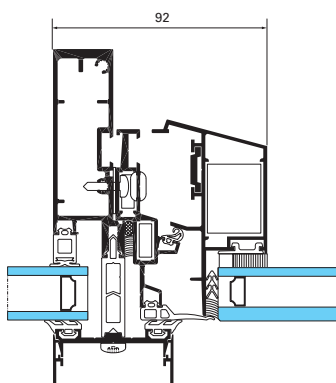

Concealed tilt-turn opening frame

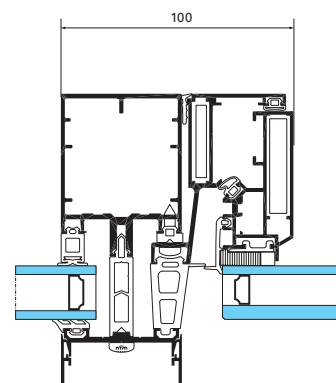

Concealed projecting top-hung opening frame

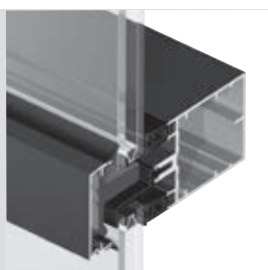

Optional punctual pressure plate (Technal patent)

Weather tightness assured primarily through the rear face by fitted vulcanised gaskets to accommodate the brise-soleil supports without reducing the weather tightness.

Thermal insulation provided by specific polyamide parts screwed to the structural's profiles, keeping the infills in place and supporting the external clip-on aluminium caps.

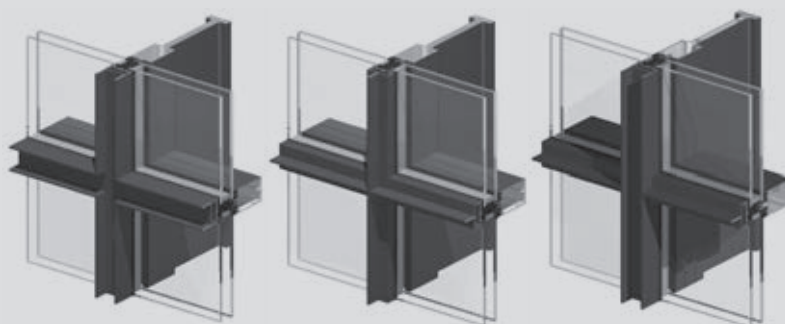
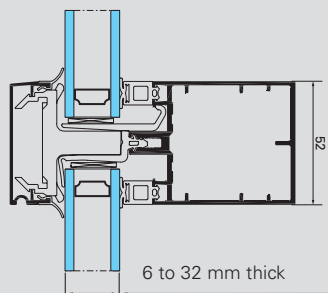

Variety in relation the appearance of the façade

The range of internal structural profiles and external caps makes it possible to vary the appearance of the façade.

Construction

- **Simplified manufacturing.** The mullions and transoms are assembled in straight cuts using a combination of moulded connectors fixed to the front and concealed anti-rotation spigots for ease of manufacture.
- **Faceted façades.** For facets up to $\pm 10^\circ$, standard connectors may be used. A special transom block combining pressure plates, caps and adaptors can be used for angles between 10° and 20° .
- **Special option.** The transom assembly block options offers an alternative to anti-rotation parts in order to meet requirements in relation to design or the project in general.

Performance

- **Advanced thermal performance.** The thermal insulation of the standard GEODE visible grid solution is provided via a 34 mm TPE insulator between the pressure plates and the mullion and transom structure. This principle ensures optimal thermal performance and meets or exceeds the building's requirements.
- **Thermal insulation** with glazing $U_g = 1.1 \text{ W/m}^2\text{K}$:
 - Fixed curtain wall with 80% glazing (opaque slab nose) $U_{cw} = 1.4 \text{ W/m}^2\text{K}$.
 - Fixed curtain walling with 50% glazing (80 mm insulating panel, $U_p=0.35$) $U_{cw} = 1.1 \text{ W/m}^2\text{K}$
- **Air, water and wind resistant** in accordance with European and CWCT standards
- **I.T.T Testing** and technical approval for the specific pressure plate option.

Thermal calculations of curtain walling carried out according to EN 13947.

GEODE “Trame” aspects

Horizontal and Vertical Trame aspect

Common structure with 52 mm-thick profiles. Choice of structural members from 4.53 cm⁴ to 2133 cm⁴ to meet the needs of each project.

Reinforced acoustic and thermal protection. GEODE Acoustic is an option designed for the GEODE system. Horizontal Trame aspect for environments requiring heightened thermal and acoustic performance.

Distinctive design details. The GEODE Trame aspect is an additional design option offering the possibility of highlighting the vertical and horizontal profiles on the building’s envelope.

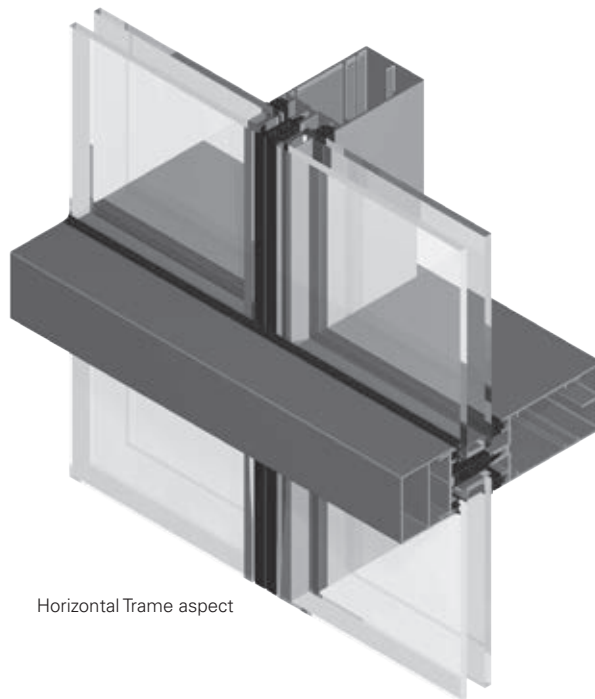

Horizontal Trame aspect

Glazing from 6 to 32 mm. Up to 42 mm for the Geode Acoustic option.

Infills are held in place with a continuous aluminium pressure plate or a specific polyamide pressure plate with fitted vulcanised gaskets.

Maximum weight of 300 kg per transom (assembled using a connector and an anti-rotation spigot).

Concealed opening vents. Projecting top-hung, parallel, tilt/turn and emergency access opening vents provide natural ventilation whilst maintaining consistent aesthetic lines whatever the external appearance of the building.

Minimal strain. On the structure of the largest mullions/transoms, the deformation of the glass is reduced thanks to a specific punctual block.

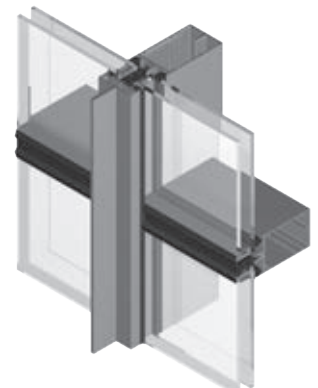

Vertical Trame aspect

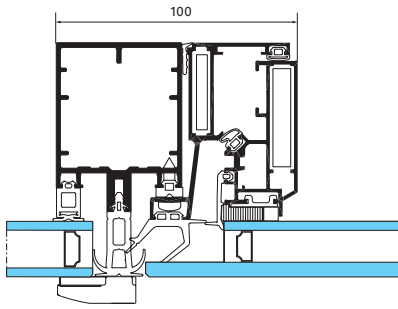

GEODE Horizontal Trame aspect with a concealed projecting top-hung

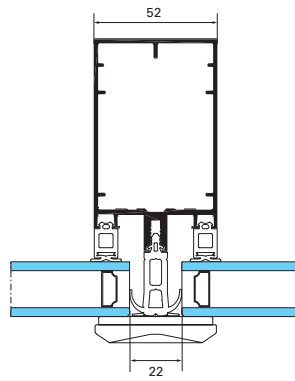

GEODE Horizontal Trame aspect

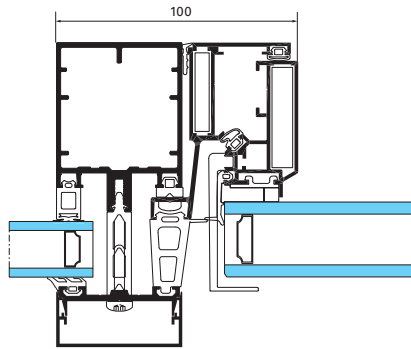
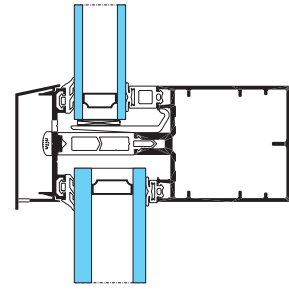

GEODE Vertical Trame aspect with a concealed projecting top-hung

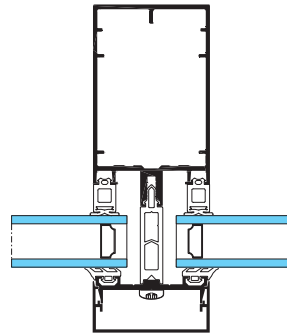

GEODE Vertical Trame aspect

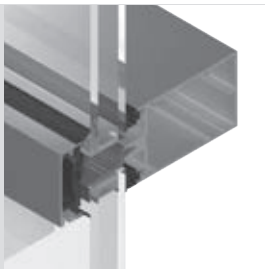
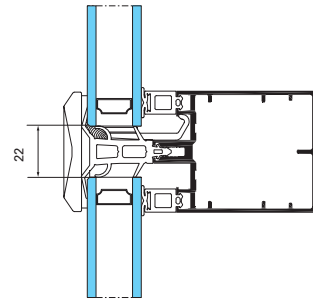

Optional punctual pressure plate (Technal patent)

assured primarily through the rear face by fitted vulcanised gaskets to accommodate the brise-soleil supports without reducing the weather tightness.

Horizontal caps clipped on to the specific pressure plates and a 22 mm "hollow" effect gasket conceals the verticals. Infills are kept in place horizontally by specific polyamide pressure plates. Specific pressure plates keep the panels up high (quantity to be defined depending on the nature of the glass components and the region).

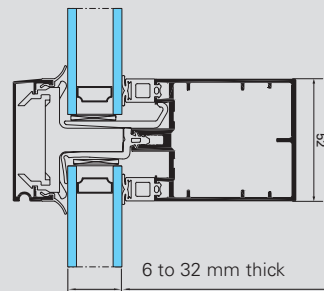

Construction

- **Contemporary design.** Depending on the type of frame, vertical or horizontal, there is a range of caps meaning that you can add depth to the facade whilst the gaskets, which are flush with the infills, conceal the verticals or horizontal.
- **Dry glazing.** The Geode Trame aspect system does not require putty to be applied on site.
- **Flat or faceted** up to 10° (only on the Horizontal Trame aspect).

Performance

- **Technical design** resistant to the most extreme climatic conditions. A pressure plate on the mullion or the transom, depending on the version, and a

combination of EPDM gaskets keep the infills in place. They ensure effective drainage by equalising the pressure through holes in the pressure blocks and caps.

- **Thermal efficiency.** The GEODE Trame aspect's thermal insulation is assured by a standard 34 mm TPE insulator between the pressure plates and the structure.

- **Thermal insulation** with glazing $u_g = 1.3 \text{ W/m}^2\text{K}$:

- Fixed curtain wall with 80% glazing (opaque slab nose) $U_{cw} = 1.6 \text{ W/m}^2\text{K}$.

- Fixed curtain wall with 50% glazing (80 mm insulating panel, $U_{cw}=0.35$) $U_{cw} = 1.2 \text{ W/m}^2\text{K}$.

- **Air, water and wind resistant** in accordance with European and CWCT standards.

- **I.T.T testing** and technical approval for the special pressure plate option.

Thermal calculations of wall cladding carried out according to EN 13947.

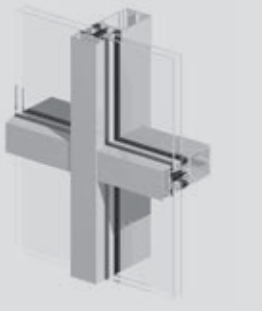

GEODE Acoustic
Visible grid

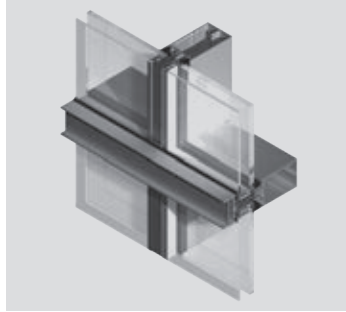

GEODE Acoustic
Horizontal frame aspect

GEODE "Trame" aspects

Acoustic

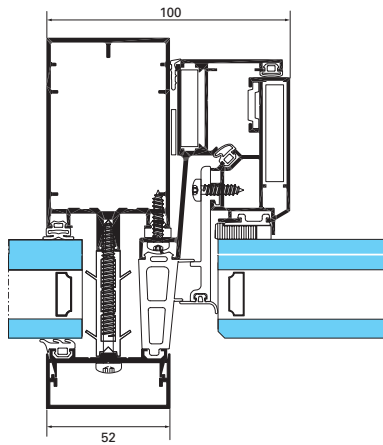

Concealed projecting top-hung
visible grid

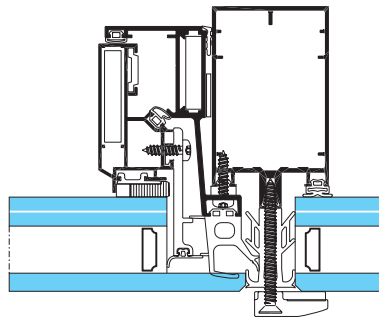

Concealed projecting top-hung,
horizontal Trame aspect

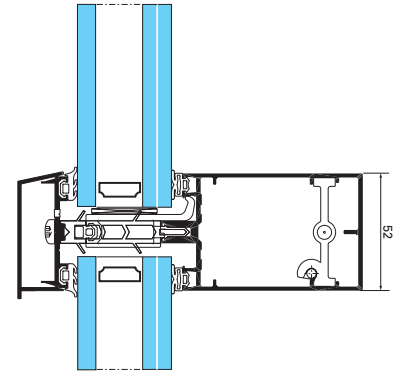

Vertical section
Visible grid or horizontal frame
aspect

Features

- **The enlarged glazing infill up to 42 mm offers greater acoustic and thermal protection.** Can be used in environments where additional performance is required (city centre apartments, hospitals, buildings close to airports and railways lines, etc.).
- **Visible grid or horizontal frame aspect.**
- **Flat or faceted curtain walling.**
Up to $\pm 20^\circ$.
- **Concealed opening vent.** The concealed SSG projecting top-hung opening frames can be supplied for use with 36 mm and 42 mm glazing.
- **System compatibility.** The profiles allow Technal's window and door systems to be integrated into curtain wall structures.

Construction

- The transoms are fixed with connectors or mounted onto blocks and can accommodate glazing infills up to a maximum weight of 240 kg per transom.

Performance

- Reinforced thermal insulation is provided through a multichamber spacing gasket and partitioning tabs.
- Thermal insulation with 42 mm triple glazing $U_g = 0.6 \text{ W/m}^2\text{K}$:
 - Fixed curtain walling with 80% glazing (opaque slab nose) $U_{cw} = 0.9 \text{ W/m}^2\text{K}$
 - Fixed wall cladding with 50% glazing (80 mm insulating panel, $U_p=0.35$) $U_{cw} = 0.8 \text{ W/m}^2\text{K}$
- Air, water and wind resistant in accordance with European and CWCT standards.
- I.T.T testing

Thermal calculations of wall cladding carried out according to EN 13947



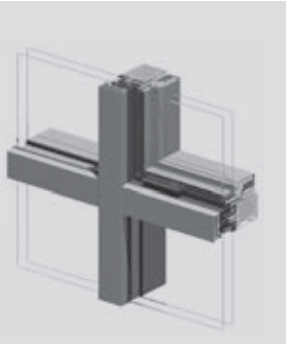

GEODE 62 version with external caps and grid aspect

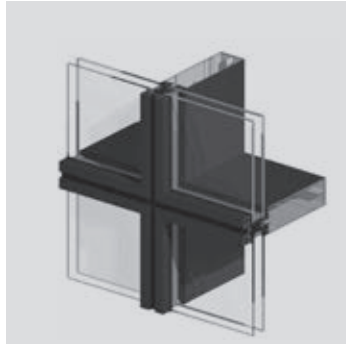

GEODE 62 version with external caps and frame aspect

GEODE "Trame" aspects

GEODE 62

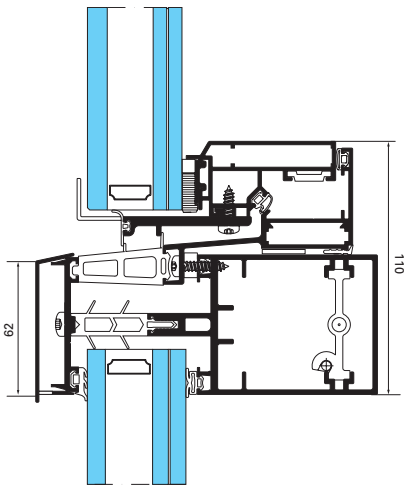

GEODE 62 concealed projecting top-hung

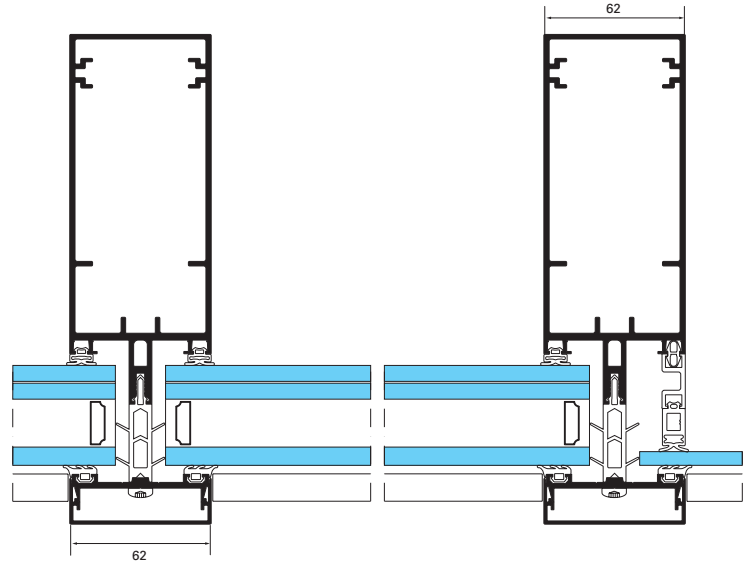

GEODE 62 Visible grid

Features

- **Large dimension glazing.** With a recess height of 25 mm, GEODE 62 is an option designed for visible grid curtain walling, enabling designers to use large glass panels to create glazed surfaces from 6 to 12 m² (semi-perimeter between 5 and 7 m) and thus to intensify the natural light.
- **Load.** The maximum load is 600 kg per transom.
- **Mullions/transoms:** from 80 to 210 mm for inertias from 92 to 1689 cm⁴.
- **Simple application.** For straight façades, this technical option uses a pressure plate, a horizontal and a vertical cap and can accommodate glazing from 8 mm to 44 mm.
- **Concealed opening vents.** The concealed projecting top-hung opening vents can be supplied with 36 mm and 42 mm glazing.
- **System compatibility.** The profiles allow Technal's window and door systems to be integrated into curtain wall structures.

Performance

- **Thermal insulation** with 44 mm triple glazing
 $U_g = 0.6 \text{ W/m}^2\text{K}$:
 - Fixed curtain walling with 80% glazing (opaque slab nose) $U_{cw} = 0.9 \text{ W/m}^2\text{K}$
 - Fixed curtain walling with 50% glazing (80 mm insulating panel, $U_p=0.35$) $U_{cw} = 0.8 \text{ W/m}^2\text{K}$
- Air, water and wind resistant in accordance with European and CWCT standards.
- I.T.T testing

Thermal calculations of wall cladding carried out according to EN 13947.



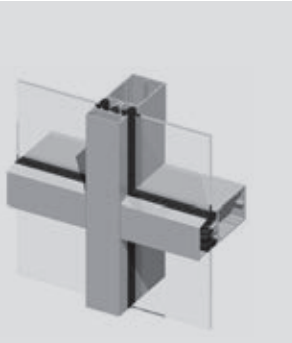

GEODE grid aspect

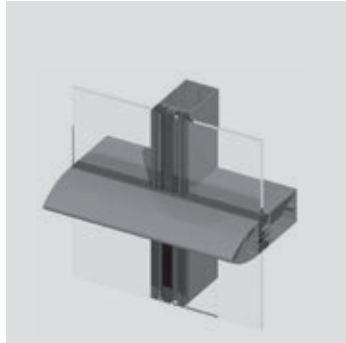

GEODE horizontal frame aspect

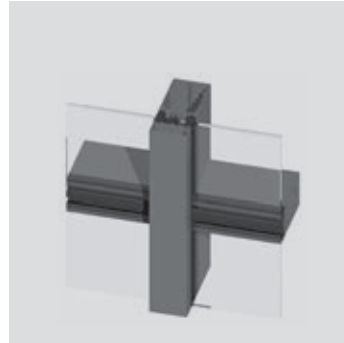

GEODE vertical frame aspect

GEODE "Trame" aspects

Single glazing

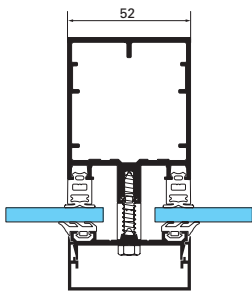

GEODE single glazing
Visible grid

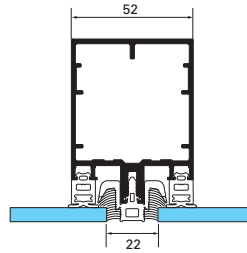
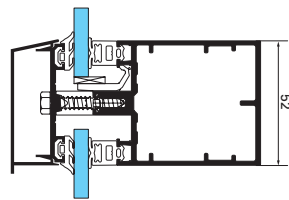

GEODE single glazing
Horizontal frame aspect

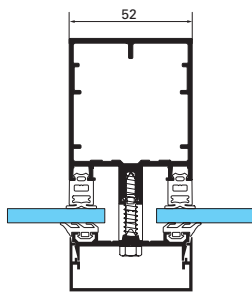
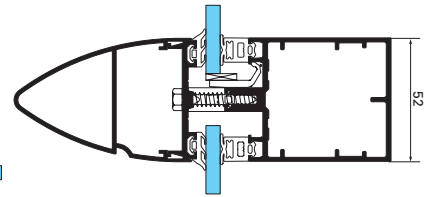

GEODE SG single glazing
Vertical frame aspect

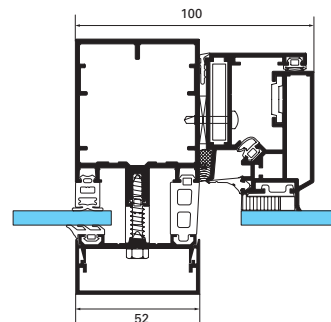
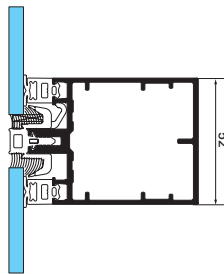

GEODE single glazing with a concealed
projecting top-hung opening frame

Features

- **Version optimised for temperate regions.** The single glazed GEODE option for the visible grid and trame aspect is dedicated to geographical regions in which the climatic conditions do not require advanced thermal performance or the use of double glazing.
- **Concealed vent option.** Structurally bonded projecting top-hung opening vents can be supplied for use with glazing from 6 mm to 11 mm.
- The GEODE single glazing system allows Technal's window and door systems to be integrated into curtain wall structures.
- **Flat and faceted façades:** up to 10°.
- **Laminated single glazing from 6 to 11 mm.**

Construction

- The internal structure and external caps can be used on the standard GEODE visible grid and trame aspect system.
- It is possible to limit the glass deflection on free side glass by a punctual piece positioned in the middle.

Performance

- **Air, water and wind resistant** in accordance with European standards.
- **I.T.T testing**



GEODE Frame aspect





GEODE Frame aspect

A contemporary alternative. The external beaded frame option of the GEODE BG system makes it possible to create curtain walling with a “frame” aspect.

Patented Technal design.

A patented “hook and toggle” fastening system facilitates the installation of the frames.

Insulation. Fixed and opening frames with a thermal break.

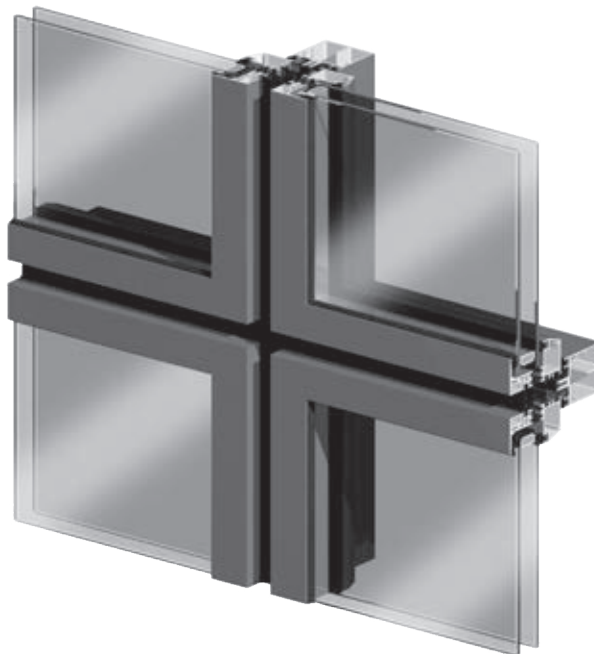

Dry glazing. The glazing is mounted onto the frames in the factory and held in place with beading.

Concealed opening frames. The concealed projecting top-hung and tilt-turn opening frames, as well as emergency access frames, are available without altering the aesthetics of the façade.

Glazing from the outside. The top and bottom glazing beads are riveted to the frame to guarantee additional security.

Glazing and infills.

GEODE BG can support glazing from 6 mm to 32 mm on the fixed sections and the opening frames.

Flat or faceted. Available as a flat façade or faceted up to $\pm 2^\circ$.

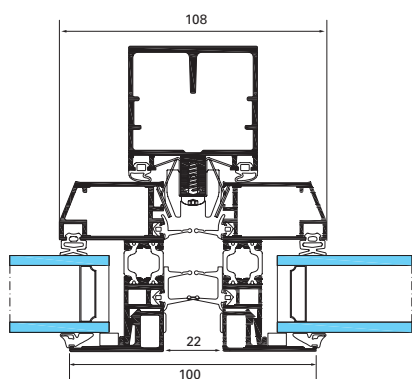

GEODE BG transparent glazing section

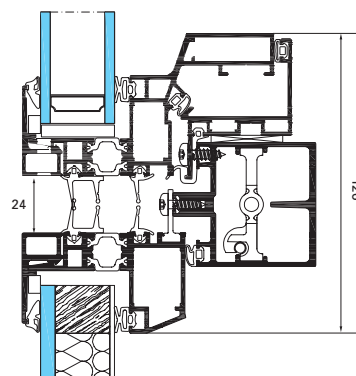

GEODE BG concealed projecting top-hung opening frame

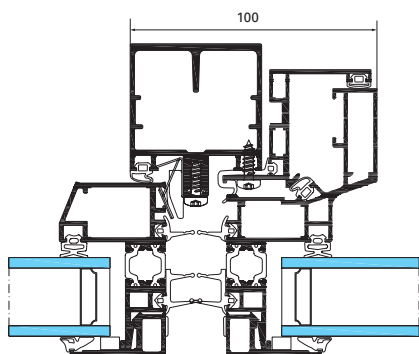

GEODE BG concealed projecting top-hung opening frames

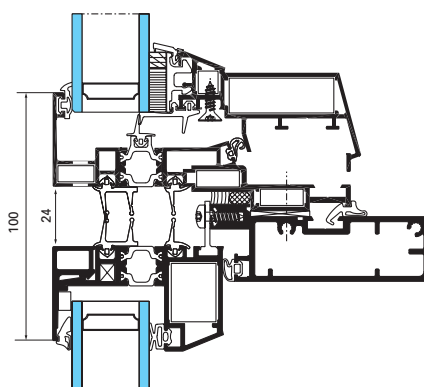

GEODE BG concealed opening frame



Construction

■ **Air tightness** . A lower EPDM compression gasket assures the system's total air tightness in the form of vulcanised corners or fitted vulcanised gaskets.

■ **Installation**. The carrying frames are fitted to the curtain wall structure with a patented hooking system.

Performance

■ **Thermal insulation** with glazing $U_g = 1.1 \text{ W/m}^2\text{K}$:

- Fixed curtain walling with 80% glazing (opaque slab nose) $U_{cw} = 1.5 \text{ W/m}^2\text{K}$

- Fixed curtain walling with 50% glazing (insulating panel) 80 mm, $U_p=0.35$ $U_{cw} = 1.2 \text{ W/m}^2\text{K}$

■ **I.T.T. testing** allows the manufacturer to use CE markings.

■ **Air, water and wind resistant** in accordance with European standards

Thermal calculations of wall cladding carried out according to EN 13947.



GEODE BG reinforced option

Version adapted to zones with high climatic or environmental requirements.

- Fixed and opening frames with a thermal break.

- **Infills**: Fixed frame up to 200 kg,

opening frames up to 120 kg (projecting top-hung) 100 kg (tilt-turn).

- **Concealed opening frame** projecting top-hung or tilt-turn.

- Straight or inclined façades +/- 3°.

- **Glazing**: From 30 to 36 mm for fixed frames with transparent glazing and projecting top-hung opening frames, 54 mm insulating panels, tilt-turn opening frame from 28 to 34 mm.

- Thermal insulation up to $U_{cw} = 1.5 \text{ W/m}^2\text{K}$

- Acoustic attenuation up to 40 dB.

- **Air, water and wind resistance** according to European and CWCT standards.

- **Quick installation of frames** using a patented Technal system.

Product available in special conditions. Contact Technal's engineering department.

GEODE All glass aspect





GEODE All Glass aspect

Mechanical structural glazing

The **GEODE mechanical structural glazing** curtain walling is a technical design enabling the creation of fully glazed façades without attaching aluminium frames to the glazing. As an alternative to SSG (Structural Sealant Glazing) which uses traditional silicone sealant, the glazing for the fixed and opening sections is attached to the aluminium frame mechanically using special aluminium supports.

From the outside, only the glazing and a thin gasket are visible.

Concealed opening vents projecting, top-hung or parallel.

Flat or faceted up to $\pm 10^\circ$.

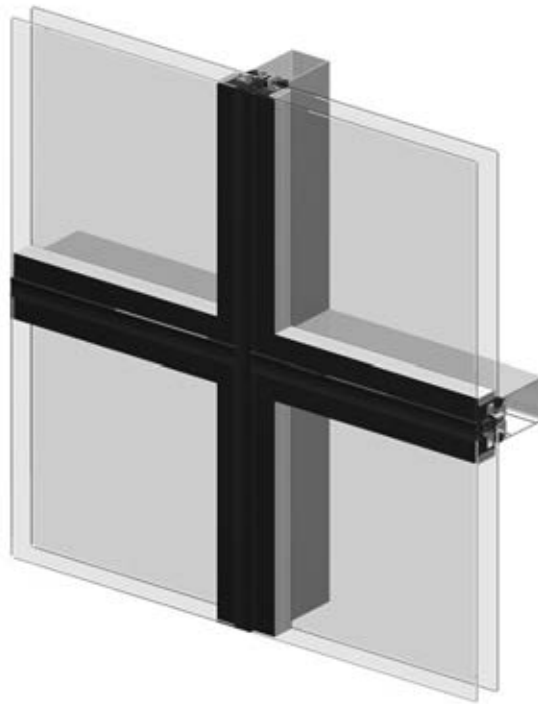

Glass panels:

Fixed frames: W 3.00 m x H 2.00 m
- Max. weight 240 kg
Opening vents: projecting top-hung 130 kg
- Parallel 150 kg.

The glazing for the fixed or opening sections is attached to and held onto the structure by specific retaining fixtures made from moulded or extruded aluminium.

Finish and weather tightness provided between the glass panel by a dry EPDM or silicone seal.

Glazing from 36 to 42 mm for the transparent sections of the fixed and opening frames. Spandrel panels with 6 or 8 mm glazing or insulating panels from 40 to 120 mm.

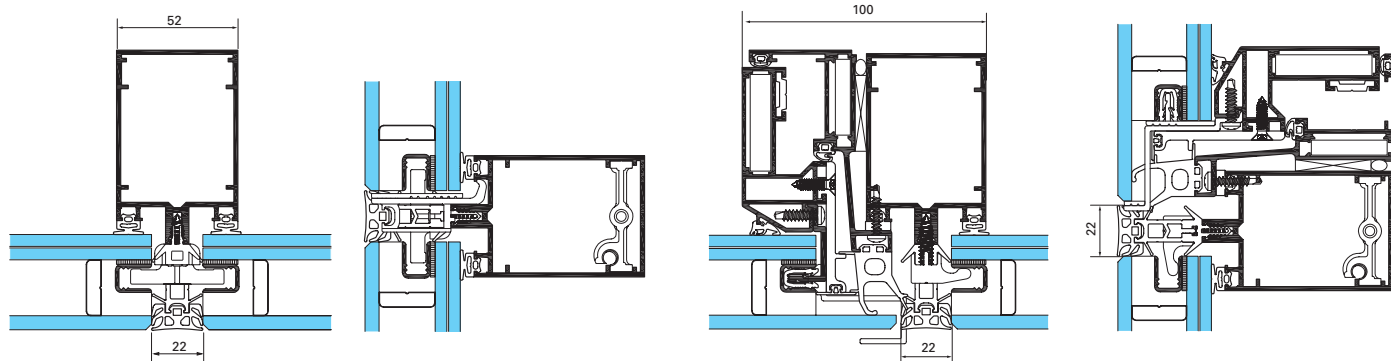

Projecting top-hung or parallel opening

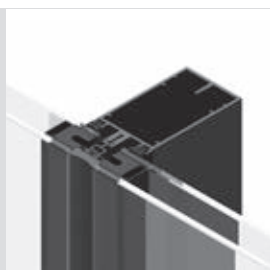

Option GEODE SG

- **Glazing and infills.** Fixed and opening frames with glazing from 32 to 34 mm for the transparent spandrel wall panel with glazing from 6 to 8 mm and 4 mm aluminium composite panels for opaque sections.
- **SSG type projecting top-hung opening vent** - max. weight 120 kg.
- **High-performance weather tightness.** A silicone gasket is positioned between the leaves on a continuous support for guaranteed optimal weather tightness.
- **Flat or faceted façade** up to +/- 5°.
- 22 mm gap between the glass panels.

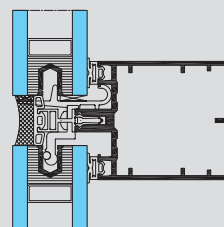

Construction

■ Glass panels

- Use of special double glazing integrating a continuous u-shaped aluminium profile between the two panes of glass inside the silicone chamber for fixing to the curtain wall structure.
- The double glazing is fixed in place with aluminium toggles positioned at regular intervals along the nose of the aluminium structure and screwed into the transoms and mullions.
- The extremities of the toggles are inserted into the u-shaped aluminium profiles between 2 panes of double glazing.

■ Opening vents

The concealed opening vents can accommodate projecting top-hung or parallel windows. The same double glazing fastening system is used for opening frames. In this case, the glass panels are held onto the opening frame by special aluminium pressure blocks and can accommodate security pieces.

Quick and easy to manufacture

- **Global reduction of costs and time** spent on site.
 - Metal builder perspective: No aluminium frames to produce and deliver to the glass manufacturer.
 - Glass manufacturer perspective: no drying/bonding time for the glass panels on the aluminium frames.
- **Glazing** fixed directly onto the aluminium structure of the curtain wall without any intermediary profile.

Performance

- **Thermal insulation** with glazing $U_g = 1.1 \text{ W/m}^2\text{K}$:
 - Fixed curtain walling with 80% glazing (opaque border) $U_{cw} = 1.5 \text{ W/m}^2\text{K}$
 - Fixed curtain walling with 50% glazing (120 mm insulating panel, $U_p=0.24$) $U_{cw} = 1.1 \text{ W/m}^2\text{K}$
- System subject to a **DTA [French technical application document]** and **I.T.T testing** allowing the manufacturer to use CE markings
- **Air, water and wind resistant** in accordance with European and CWCT standards.

GEODE All Glass aspect

Structural Sealant Glazing (SSG)

Less visible aluminium. The GEODE SSG systems meets the demand for glazed façades with a smooth finish and no externally visible aluminium. The glass panels are bonded onto the aluminium frames with silicone.

Quality assurance. The system is manufactured and bonded in the factory by certified companies in accordance with European standards.

Concealed opening vents. Concealed projecting top-hung and tilt-turn opening vents as well as emergency access frames are available and ensure the homogeneity of the façade.

Patented design. A patented hanging system facilitates onsite installation.

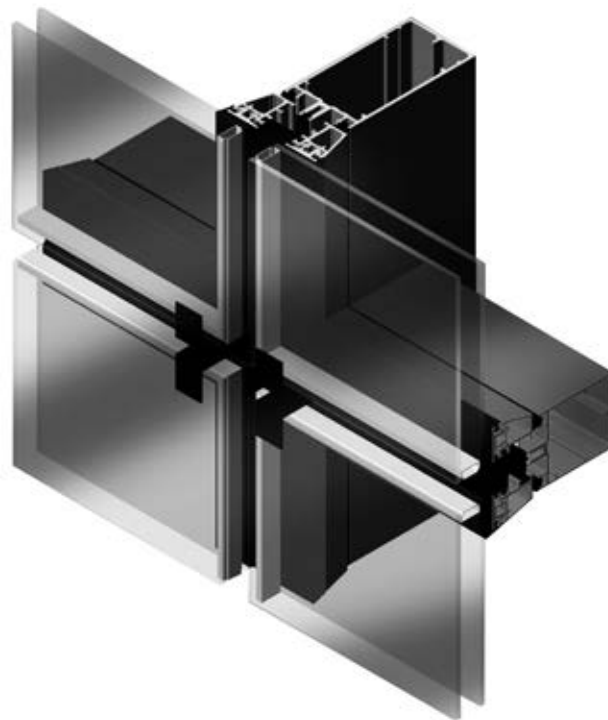

Flat or faceted façade
up to $\pm 2^\circ$.

The SSG glazing, with rounded edges on all four sides are offset at the top to allow water to drain away and to improve performance.

Shadow gaskets of 22 mm between glazed panels.

Loads. The glazing is supported by a glass security support at each corner of the aluminium support frame. Each fixed frame can therefore receive glass with a maximum weight of 80 kg.

Glazing and infills. The GEODE SSG system can receive 6 mm glazing in front of the opaque sections, 23 mm or 31 mm for insulating glazing or insulating panels of 60 mm.

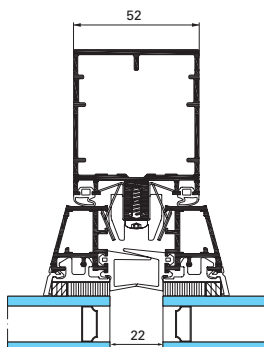

GEODE SSG fixed frame

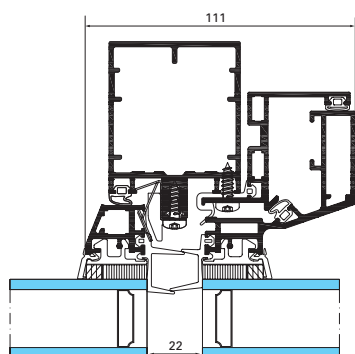
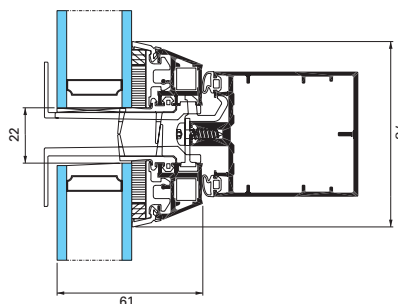

GGEODE SSG concealed projecting top-hung opening frame

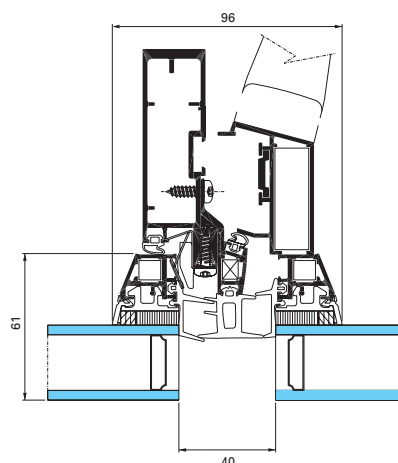

GEODE SSG concealed tilt-turn opening frame

Construction

- **Air tightness.** An internal EPDM compression gasket assures the system's total air tightness in the form of vulcanised corners or fitted vulcanised gaskets.
- **Quick installation.** The SSG frames are installed onto the curtain wall's structure with a patented hooking system.

Performance

- **Thermal insulation** with glazing $U_g = 1.1 \text{ W/m}^2\text{K}$:
 - Fixed curtain walling with 80% glazing (opaque slab nose) $U_{cw} = 1.8 \text{ W/m}^2\text{K}$
 - Fixed wall cladding with 50% glazing (insulating panel) 50 mm, $U_p=0.54$ $U_{cw} = 1.8 \text{ W/m}^2\text{K}$
- SSG subjected to **ATE and I.T.T testing** allowing the manufacturer to use CE markings
- **Air, water and wind resistant** in accordance with European standards.

Thermal calculations of wall cladding carried out according to EN 13947.



GEODE reinforced SSG option

Version adapted to zones with high climatic or environmental requirements.
- Fixed frames up to 200 kg,

- opening frames up to 120 kg.
- **Projecting top-hung opening frame**
- Flat or faceted façades +/- 3°.
- **Glazing:** of 6, 28 and 34 mm for the transparent section, 54 mm insulating panels, 28 and 34 mm opening frames.
- **Thermal insulation** reinforced up to $U_{cw} = 1.6 \text{ W/m}^2\text{K}$
- Acoustic attenuation up to 40 dB.
- **Air, water and wind resistance** according to European and CWCT standards.
- **Quick installation of frames** using a Technal patented system.

Product available in special conditions. Contact Technal's engineering department.

GEODE

Roof lights



E 109 E 110
E 110 E 111



Features

Homogenous appearance. These solutions offer designers the possibility to create inclined roofs, vaults, atriums and pyramids that are fully compatible and visually coherent with GEODE vertical façade.

GEODE Visible grid:

Specially designed cap. A special cap for the horizontal and vertical sections reduces the accumulation of water on the inclined sections.

GEODE Vertical frame aspect:

Minimal strain. The vertical caps and a silicone gasket with pressure blocks on the transoms prevent the glass from becoming misshapen in the event of negative wind pressure.

Glazing. The double glazing is manufactured using structural silicone.

Incline. Minimum slope: 10° for single glazing 15° for double glazing.

Construction

- The 8 mm to 32 mm infills are held in place with horizontal and vertical pressure plates for the GEODE Visible grid system and by vertical pressure plates and horizontal pressure blocks for the GEODE Vertical frame aspect system.
- Design details. The rafters and transoms are square cut and assembled using the penetrating transom principle.

Performance

- Effective drainage. Drainage takes place at the end of the transoms via the rafters.
- Resistance to climatic conditions. The weather tightness of the grid system is assured via an internal EPDM gasket and external butyl tape. The weather tightness of the GEODE Vertical Frame for the Visible Grid version is assured by EPDM gaskets and a silicone gasket on the transoms.

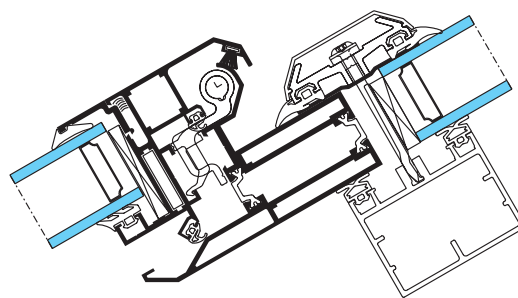
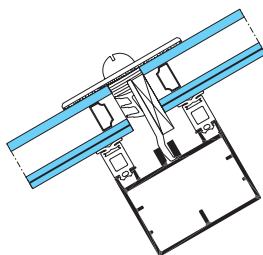
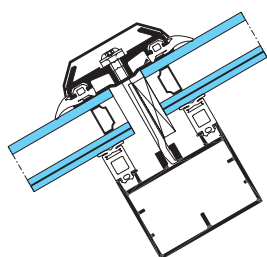
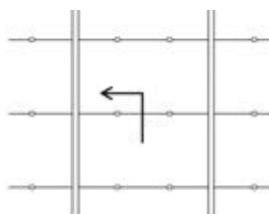
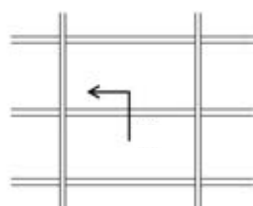

GEODE Roof light,
Visible Grid

GEODE Roof light with Vertical Frame

GEODE Roof-mounted opening

Applications

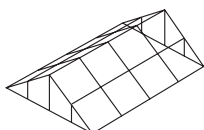

Lantern

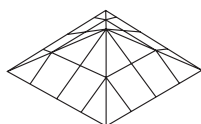

Pyramid

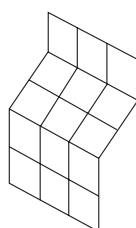

Roof light

Performance





Performance

Weather resistance

A sample curtain wall has been tested for each of the following systems in accordance with NF standards (French standard), meeting the specific curtain wall requirements of the European standard EN 13830.

The GEODE range also meets the requirements of the CWCT standard concerning building envelopes. Further information is available upon request.

| | | GEODE | Air tightness | Water tightness | Wind resistance |
|-----------------------------|-------------------------------|-----------------------------|---------------|---|--|
| TRAME ASPECTS | VISIBLE GRID | FIXED | A4 | R7 | Satisfactory results under pressure and depression-1600 and 2400 pa (sudden pressure) |
| | | PROJECTING TOP-HUNG OPENING | A3 | E1200 | VC5 |
| | HORIZONTAL TRAME | FIXED | A4 | R7 | Satisfactory results under pressure and depression-1600 and 2400 pa (sudden pressure) |
| | | PROJECTING TOP-HUNG OPENING | A4 | E9A | VC3 |
| | VERTICAL TRAME | FIXED | A4 | R7 | Satisfactory results under pressure and depression-1600 and 2400 pa (sudden pressure) |
| | | PROJECTING TOP-HUNG OPENING | A4 | E8A | VC3 |
| | ACOUSTIC | VISIBLE GRID | A4 | E1200 | Satisfactory results under pressure and depression-1600 and 2400 pa (sudden pressure)) |
| | | HORIZONTAL | A4 | E750 | Satisfactory results under pressure and depression-1600 and 2400 pa (sudden pressure) |
| | | PROJECTING TOP-HUNG OPENING | A4 | E1050 | VC3 |
| | GEODE 62 | VISIBLE GRID | A4 | R7 | Satisfactory results under pressure and depression-1600 and 2400 pa (sudden pressure) |
| PROJECTING TOP-HUNG OPENING | | A4 | E1050 | VC3 | |
| SINGLE GLAZING | VISIBLE GRID | AE | RE1650 | Satisfactory results under pressure and depression-1600 and 2400 pa (sudden pressure) | |
| | HORIZONTAL TRAME | AE | RE900 | Satisfactory results under pressure and depression-1600 and 2400 pa (sudden pressure) | |
| | PROJECTING TOP-HUNG OPENING | A4 | E1200 | VC2 | |
| FRAME AS. | BEADED GLAZING | FIXED | A4 | R7 | Satisfactory results under pressure and depression-1600 and 2400 pa (sudden pressure) |
| | | PROJECTING TOP-HUNG OPENING | A4 | E9A | VC3 |
| REINFORCED BG VERSION | FIXED | A4 | R7 | Satisfactory results under pressure and depression-2400 and 3600 pa (sudden pressure) | |
| ALL GLASS ASPECT | MECHANICAL STRUCTURAL GLAZING | FIXED | A4 | R7 | Satisfactory results under pressure and depression-1200 and 1800 pa (sudden pressure) |
| | | PROJECTING TOP-HUNG OPENING | A4 | RE900 | VC3 |
| | SG VERSION STRUCTURAL GLAZING | FIXED | A4 | E1200 | Satisfactory results under pressure and depression - 2500 pa |
| | SSG | FIXED | A4 | R7 | Satisfactory results under pressure and depression-1600 and 2400 pa (sudden pressure) |
| | | PROJECTING TOP-HUNG OPENING | A4 | E9A | VC3 |
| SSG VERSION REINFORCED | FIXED | A4 | R7 | Satisfactory results under pressure and depression-2400 and 3600 pa (sudden pressure) | |



Thermal performance

The precise performance depends on a combination of the size of the frames, the thickness of the glass, the type of infill and the options chosen. The values below are provided for information purposes only. Further information is available upon request.

Ucw coefficient of curtain walling without protection (W/m².K)

| | | Ug insulation coefficient of glazing (W/m².K) | | | | | | | | | | |
|------------------|------------------------|---|-----|-----|-----------------------------|-----------------------------|-----|-----|-----|-----|-----|-----|
| | | Triple glazing | | | | Double glazing | | | | | | |
| | | 0,6 + int. insulating | 0,6 | 0,8 | 1,0 + int. insulating | 1,1 + int. insulating | 1,0 | 1,1 | 1,3 | 1,5 | 1,7 | 1,9 |
| Frame Aspect | Grid | | | | 1,2 | 1,3 | 1,3 | 1,4 | 1,5 | 1,6 | 1,8 | 1,9 |
| | Grid v. Acoustic | 0,9 | 1,0 | 1,1 | 1,2 | 1,3 | 1,3 | 1,4 | 1,5 | 1,6 | 1,8 | 1,9 |
| | Horizontal | | | | 1,2 | 1,3 | 1,3 | 1,4 | 1,5 | 1,6 | 1,8 | 1,9 |
| | Horizontal v. Acoustic | 0,9 | 1,0 | 1,1 | 1,2 | 1,3 | 1,3 | 1,4 | 1,5 | 1,6 | 1,8 | 1,9 |
| | 62 Grid | 0,9 | 1,0 | 1,1 | 1,2 | 1,3 | 1,3 | 1,4 | 1,5 | 1,6 | 1,8 | 1,9 |
| All Glass Aspect | Structural glazing* | | | | 1,4 | 1,5 | 1,5 | 1,6 | 1,7 | 1,8 | 2,0 | 2,1 |
| | SSG | | | | 1,7 | 1,8 | 1,8 | 1,8 | 2,0 | 2,1 | 2,2 | 2,4 |
| | Reinforced SSG version | | | | | | | 1,8 | 1,9 | 2,1 | 2,3 | 2,4 |
| Frame Aspect | BG | | | | 1,4 | 1,5 | 1,5 | 1,6 | 1,7 | 1,8 | 1,9 | 2,1 |
| | Reinforced BG version | | | | | | | 1,7 | 1,9 | 2,1 | 2,2 | 2,4 |

100% glazed on the inside:
transparent glazed section +
opaque slab nose
2 frames per level:
W = 1.35 m x H slab nose =
0.70 m + transparent glazing
= 2.50 m.
insulating, extruded
polystyrene, 50 mm thick
(Up = 0.54)

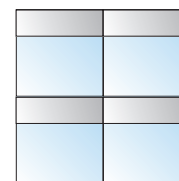

* insulator ACERMI 40 mm (Up = 0,66)

Ucw coefficient of curtain walling without protection (W/m².K)

| | | Coefficient Ug d'isolation des vitrages(W/m².K) | | | | | | | | | | |
|------------------|------------------------|---|-----|-----|-----------------------------|-----------------------------|-----|-----|-----|-----|-----|-----|
| | | Triple glazing | | | | Double glazing | | | | | | |
| | | 0,6 + int. insulating | 0,6 | 0,8 | 1,0 + int. insulating | 1,1 + int. insulating | 1,0 | 1,1 | 1,3 | 1,5 | 1,7 | 1,9 |
| Frame aspect | Grid | | | | 1,1 | 1,1 | 1,1 | 1,2 | 1,3 | 1,3 | 1,4 | 1,5 |
| | Grid v. Acoustic | 0,9 | 1,0 | 1,0 | 1,1 | 1,1 | 1,1 | 1,2 | 1,3 | 1,3 | 1,4 | 1,5 |
| | Horizontal | | | | 1,1 | 1,2 | 1,2 | 1,2 | 1,3 | 1,4 | 1,5 | 1,6 |
| | Horizontal v. Acoustic | 0,9 | 1,0 | 1,1 | 1,1 | 1,1 | 1,2 | 1,2 | 1,3 | 1,4 | 1,4 | 1,5 |
| | 62 Grid | 0,9 | 1,0 | 1,1 | 1,1 | 1,1 | 1,1 | 1,2 | 1,3 | 1,3 | 1,4 | 1,5 |
| All Glass Aspect | Structural glazing* | | | | 1,3 | 1,4 | 1,4 | 1,4 | 1,5 | 1,6 | 1,7 | 1,7 |
| | SSG | | | | 1,7 | 1,8 | 1,8 | 1,8 | 1,9 | 2,0 | 2,1 | 2,1 |
| | Reinforced SSG version | | | | | | | 1,6 | 1,7 | 1,8 | 1,9 | 2,0 |
| Frame aspect | BG | | | | 1,4 | 1,4 | 1,4 | 1,4 | 1,5 | 1,6 | 1,7 | 1,7 |
| | Reinforced BG version | | | | | | | 1,5 | 1,6 | 1,7 | 1,8 | 1,8 |

60% glazed on the inside:
glazed transparent section
+ opaque apron wall 2
frames per level
W = 1.35 m x H transparent
glazing = 1.50 m + apron
wall = 1.00 m. 50 mm thick
extruded polystyrene
insulator (Up = 0.54)

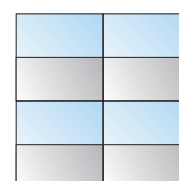

* insulator ACERMI 40 mm (Up = 0,66)



1



2



3

1. Architect: Luis Pérez Salamanca Photography: DR Technal
2. Architects: Cabinet BROCHET LAJUS PUEYO Photography: ABBADIE Hervé
3. Architects: TETRARC Photography: Stéphane Chalmeau