













































Amwell

Washrooms from concept to completion

Delivery Note Number:

					Fixing Instructions	Minima
						
						
						
						
						
						

Cleaning & Maintenance

Cleaning Laminate Components:

Always start by trying the gentlest method of cleaning. If a stain persists, work through the following steps, repeating each step several times if the stain seems to be disappearing.

Step 1: For routine cleaning, use a damp cloth or sponge and a mild soap or detergent. Rinse the panels and dry on completion.

Step 2: For difficult stains apply a mild household cleaner detergent with a soft bristled brush.

Step 3: If stubborn stains persist, use a non-scratch cleaner scrubbing lightly with a soft bristled brush for 10 to 20 seconds.

Step 4: If a stain persists, apply undiluted household bleach, let it stand for no longer than 2 minutes, and rinse thoroughly with warm water. **DO NOT** expose the laminate surface to household bleach for prolonged periods of time, as this may lead to permanent discolouration.

Step 5: If the surface has been discoloured through long exposure to industrial grime, clean carefully with a cream cleaner containing a mild abrasive.

DO: Always rinse thoroughly after cleaning (residue from cleaning solutions is the single greatest cause of damage to laminate surfaces).

DO: Wipe up spills immediately, and rinse thoroughly.

DO NOT: use acidic or abrasive cleaners, expose the laminate to household bleach for prolonged periods of time, or apply excessive scrubbing, especially on gloss finish surfaces.

Cleaning Ironmongery:

Powder Coated products should be cleaned at no more than three month intervals. Detergent diluted with warm water should be used. A soft cloth, natural sponge or a soft bristle brush may be used. Abrasive materials should be avoided. White spirit may be used to remove oil or grease deposits, but strong solvents must be avoided. The coated items must be thoroughly rinsed following the use of detergents.

Metallic surfaces should be cleaned as detailed for powder coating. Care should be taken in order avoid scratching the metallic surface.

Maintenance of Ironmongery

Cubicle locks and hinges should be wiped clean. A moderate amount of silicone type lubricant (such as WD40) should be applied periodically to all moving parts, with any excess promptly removed. Excess use of lubricants may attract dust, which will increase the wear rate of moving parts. It is imperative that the amount of lubricant is kept to a minimum. All fixing bolts etc. should be checked periodically and tightened as required.

General Comments:

In order to avoid water marks/ lime scale build up, standing water should be removed from horizontal surfaces. Any water that has splashed onto a panel edge should be removed immediately.

Recommendations for 12.5mm Solid Grade Laminate

Machining

- The machining of Compact laminate should be done using tungsten carbide tipped blade/ cutters or metal cutting tools.

Cutting

- In order to obtain a clean cut, we suggest the use of carbide tipped saw blades with trapezoidal and as many teeth as possible or a jigsaw with a metal cutting blade. However, alternating teeth can be equally suitable, but the cut will not be as clean.
- Best results can be obtained with horizontally fixed saws.

Precision Cutting

- A clean edge without flaking can be obtained. The best quality cut can be obtained by firstly, sawing the panel slightly oversize and then re-cutting the edge to the precise measurement using a tungsten carbide tipped router cutter of the required profile running at 18,000 to 22,000 rpm.

Grooving

- Compact can be grooved using a saw blade or router cutter with tungsten carbide tips.
- The depth of the groove must not exceed 1/3 of the Compact thickness.

Drilling

- Carbide bits with 3 prongs give best results (helical bits) and can be used in preference to high-speed steel drills.
- Holes can be drilled through part of the thickness or through the whole. In the case of stopped holes, a minimum thickness of 1.5mm to 2mm of the laminate must remain (i.e. maximum depth of hole = 11mm). A minimum of 1mm of space must remain between the tenon, screw tip or insert and the bottom of the hole (otherwise there is a risk of the laminate cracking when fitting)
- Pilot hole diameters for self tapping screws are: 3.5mm - No.6 screw; 3.5mm - No.8 screw; 4.5mm - No.10 screw; 5mm - No.12 screw.

Cut-Outs

- Square Cut-outs:- Drill the four corners with at least a 10mm diameter hole and, starting from one of the holes, use a jigsaw with a metal cutting blade, cutting in straight lines, join the holes and square into the corners. Finish with a metal file (semi-soft), ensuring that all sharp arises are removed to avoid injury.
- Oval or Circular Cut-outs:- For example, cutting a basin hole into a vanity top. Drill a single 10mm diameter hole and, starting from the hole, cut according to template using a jigsaw with a metal cutting blade. Finish with a metal file (semi-soft), ensuring that all sharp arises are removed to avoid injury.

Resizing and re-edging previously finished SGL panels

- We would recommend that you cut the panel as previously described and trim to size using a 'TREND' Sunk Bead Router Cutter running at 18,000 to 22,000 rpm and finish with a 300 grit sand paper.
- Polish as described below.

Finishing edges

- In order to eliminate machine-cutting imperfections created at the edges of the Compact, sand with a 300 grit sand paper to a fine finish.
- To obtain darker edges, rub the edge with a cloth soaked in linseed oil or wax. Leave to dry for 30 minutes and wipe off. Sharp edges must be smoothed to avoid injury.

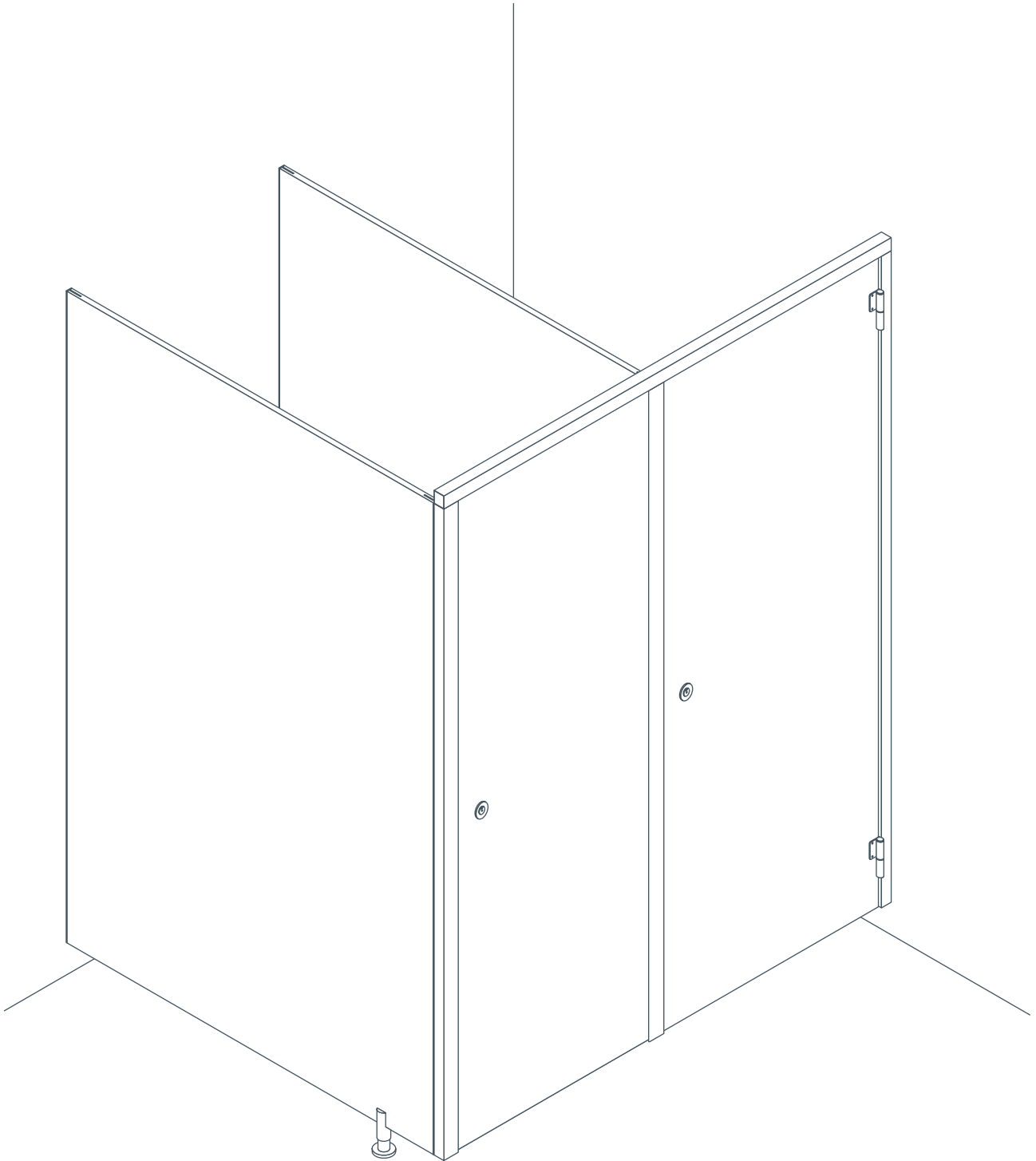

T-Section to Wall Fixing Details (HPL Only)

i)

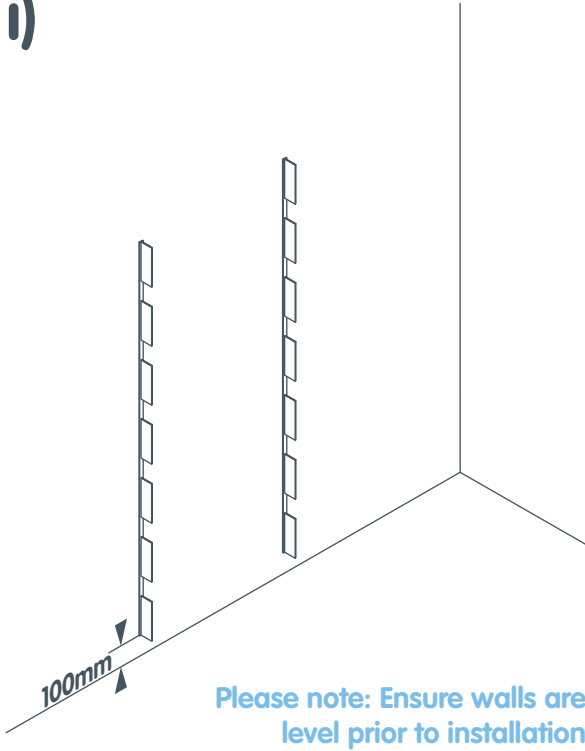

Please note: Ensure walls are level prior to installation

ii)

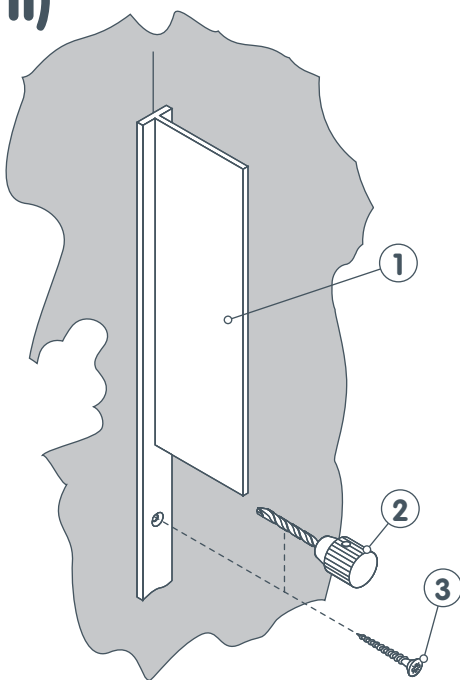

1. T-Section
2. Drill to suit wall type
3. No. 8 x 2" csk screws

Channel Bracket to Wall Fixing Details (SGL Only)

i)

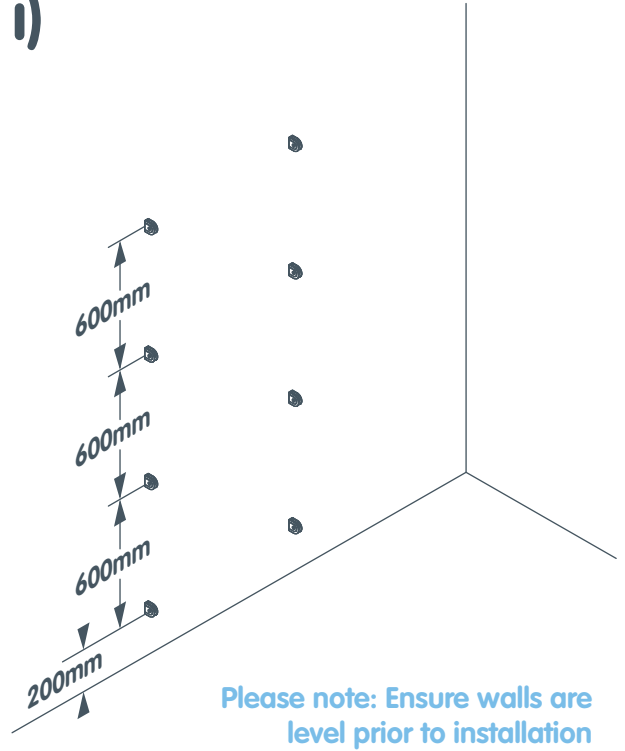

Please note: Ensure walls are level prior to installation

ii)

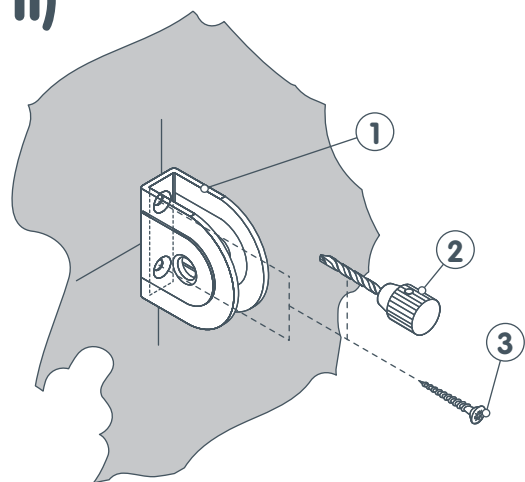

1. Channel bracket
2. Drill to suit wall type
3. No. 8 x 2" csk screws

1

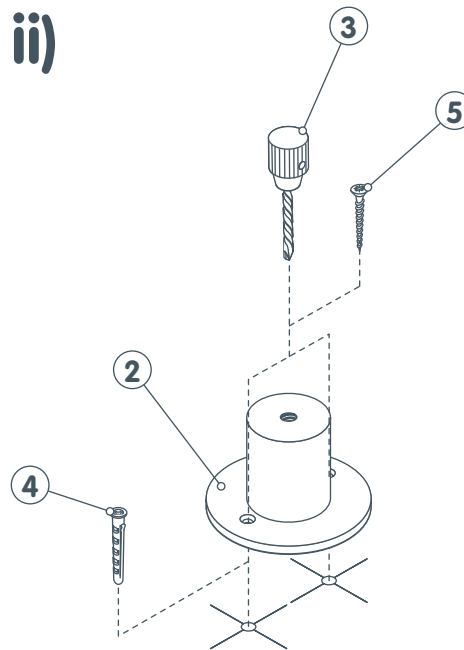
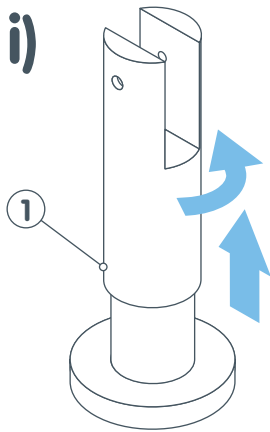

2

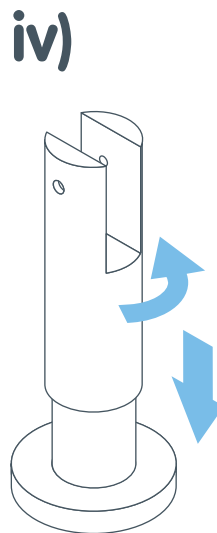
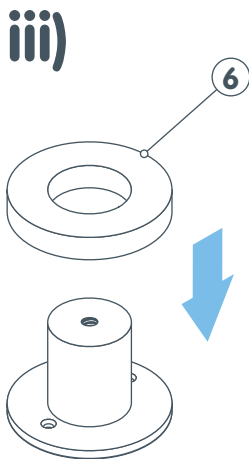

- 1. Pedestal body
- 2. Pedestal base
- 3. Drill pilot hole to suit floor
- 4. Rawl plug
- 5. 50mm x 5mm csk screw
- 6. Cover rose

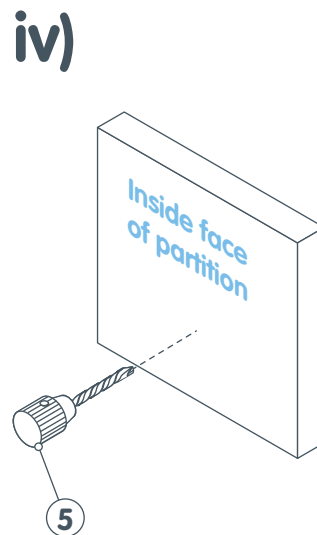
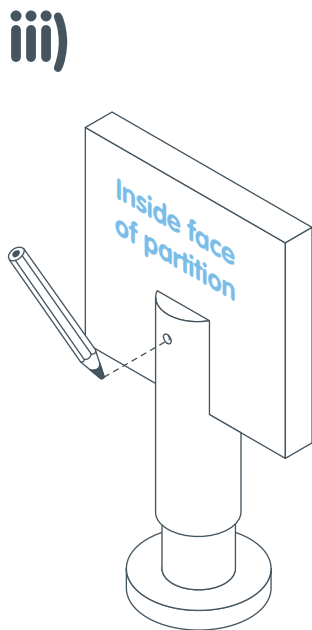
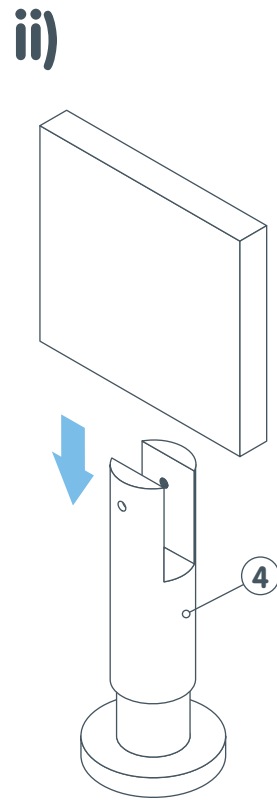
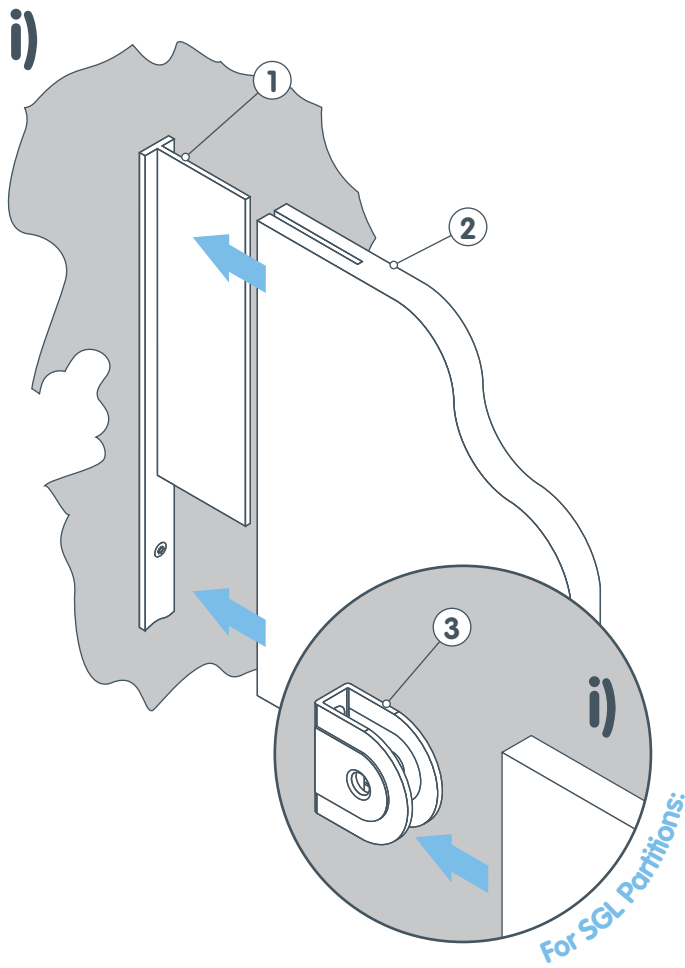

- 1. T-section
- 2. Partition
- 3. Channel bracket
- 4. Pedestal body
- 5. Drill 4.5mm dia. through hole

3

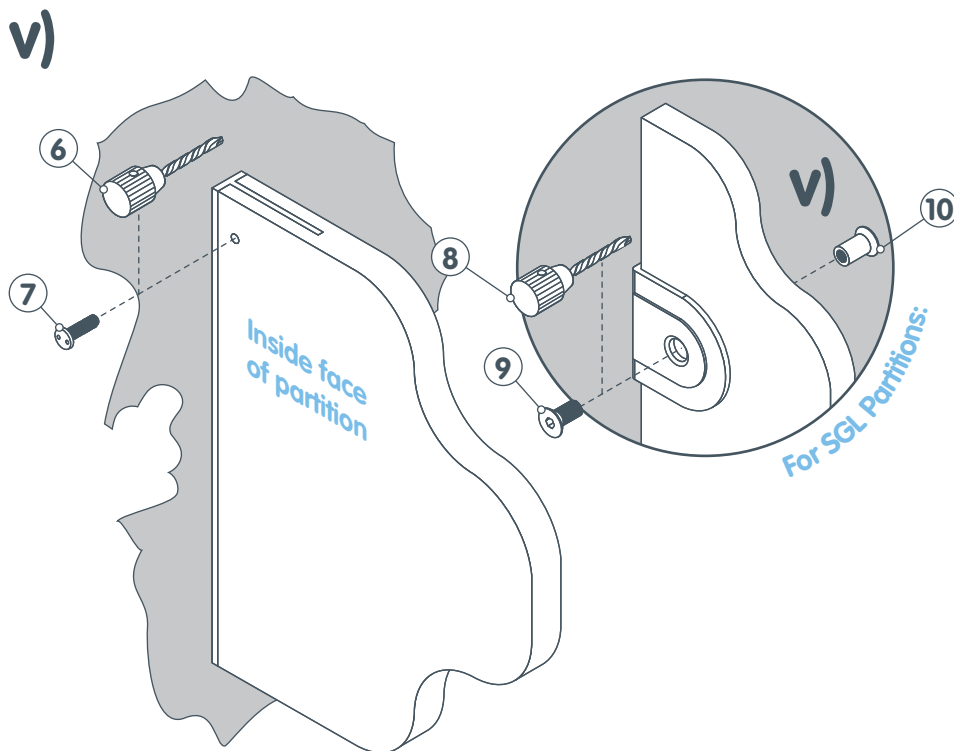

3

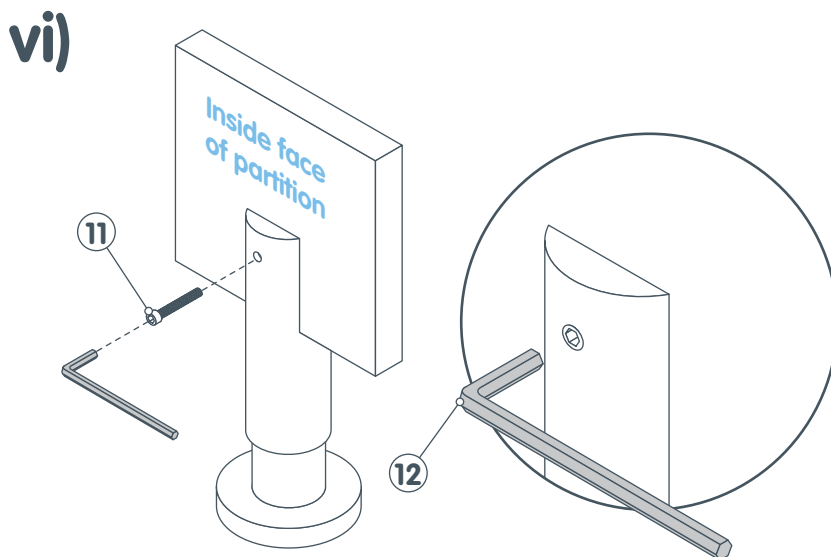

- 6. Drill 5mm dia. holes 13mm deep (to line up with holes in t-section)
- 7. M5 x 12mm snake eye screws
- 8. Drill 8mm dia. through holes
- 9. M6 x 14mm csk socket stainless steel screw
- 10. Multirol barrel
- 11. T-nut screw
- 12. Allen key

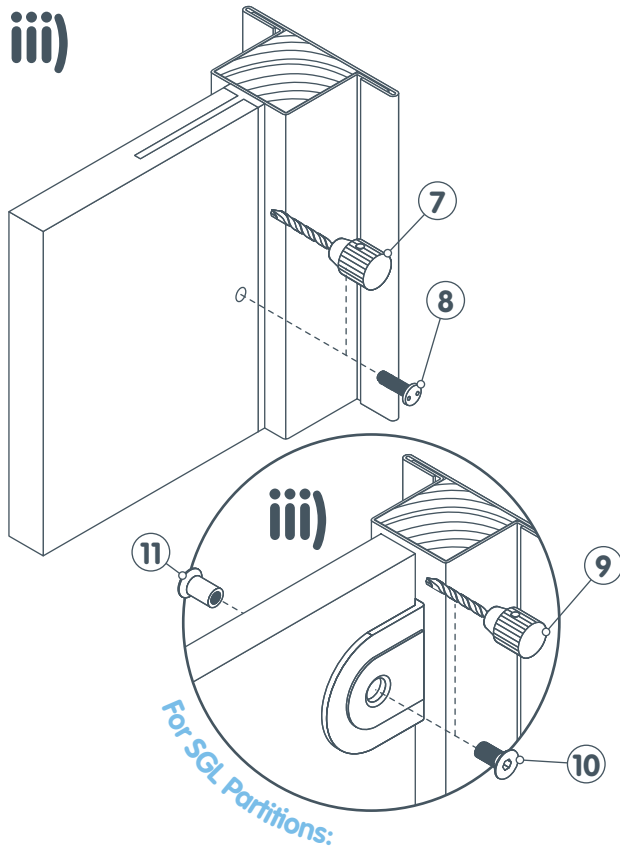
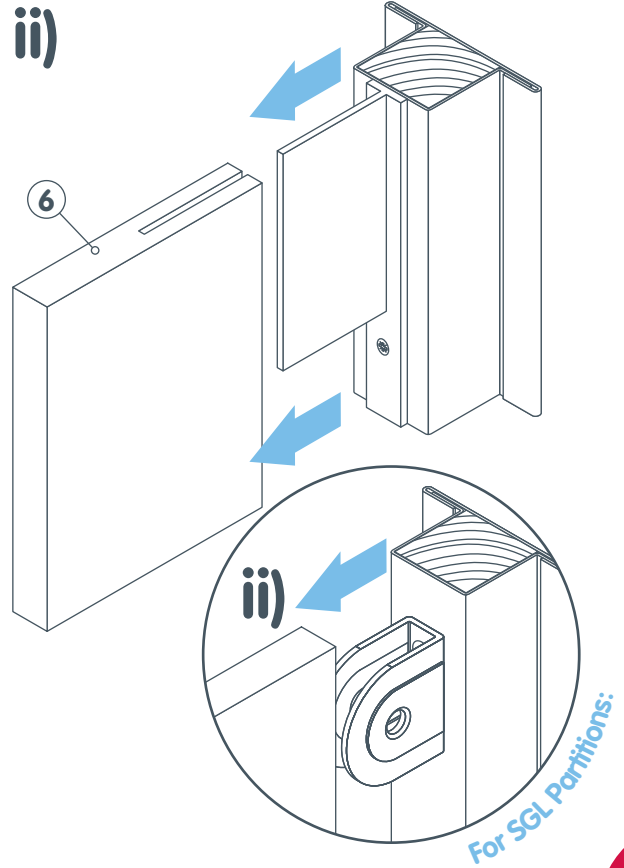
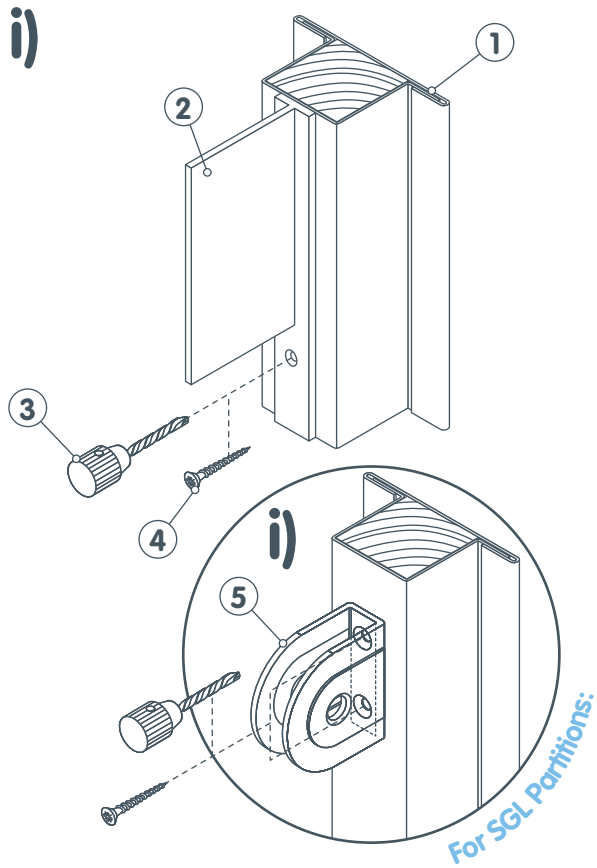

1. Intermediate/return end pilaster
2. T-section
3. Drill 3mm dia. through hole
4. No. 8 x 1" csk screws
5. Channel bracket
6. Partition
7. Drill 4.5mm dia. holes 13mm deep (to line up with holes in T-section)
8. M5 x 12mm snake eye screws
9. Drill 8mm dia. through holes
10. M6 x 14mm csk socket stainless steel screw
11. Multirol barrel

i)

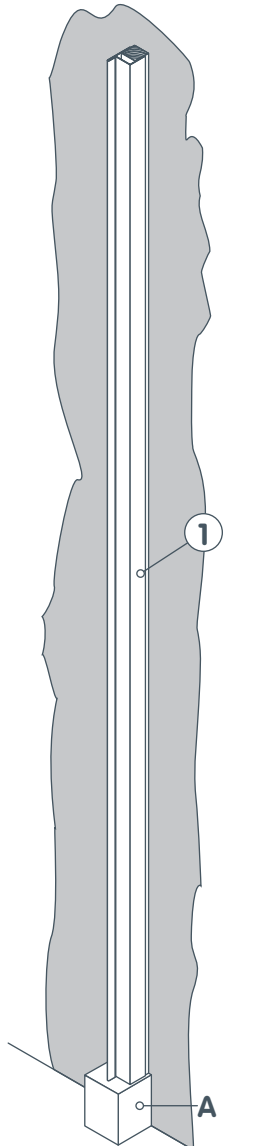

ii)

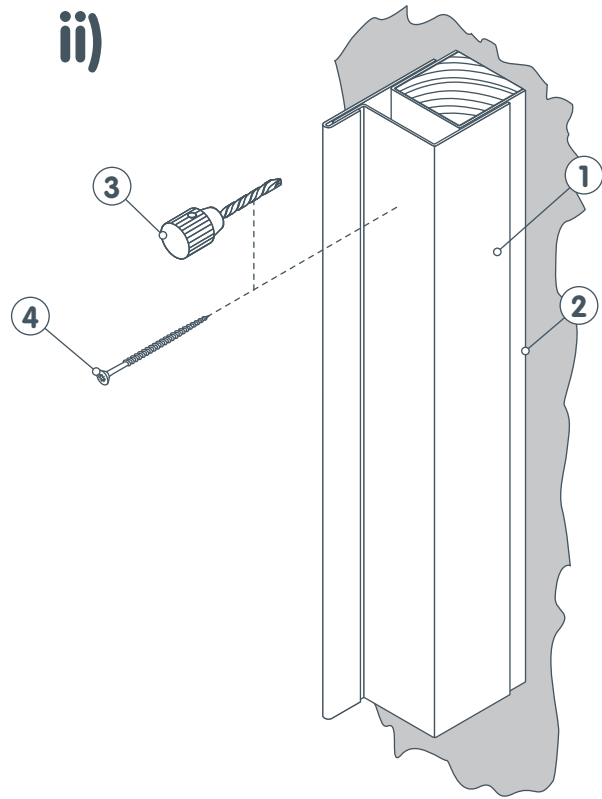

5

A = 100mm
support block
(supplied by others)

- 1. Wall end pilaster block
- 2. Wall end pilaster extrusion
- 3. Drill to suit wall type
- 4. No.10 x 3" screws

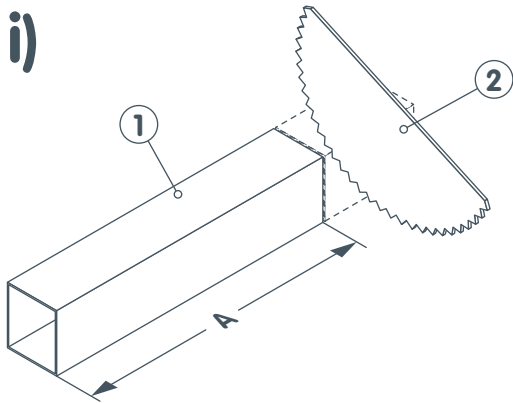

A = Cut length to suit

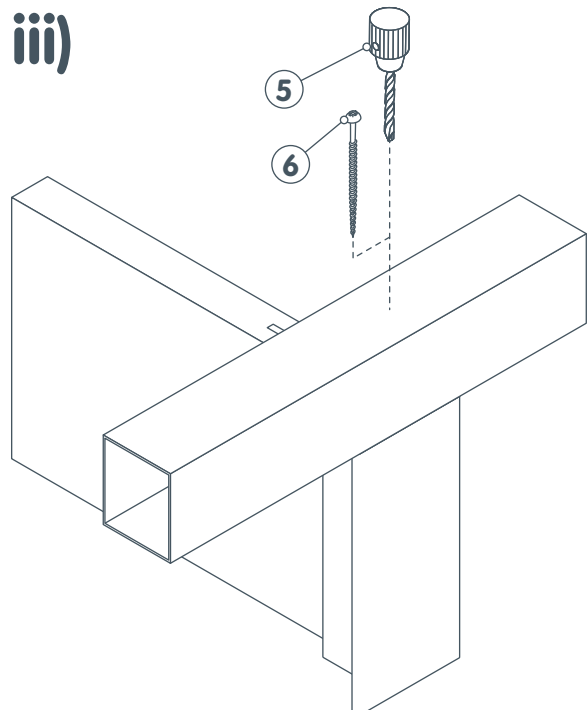
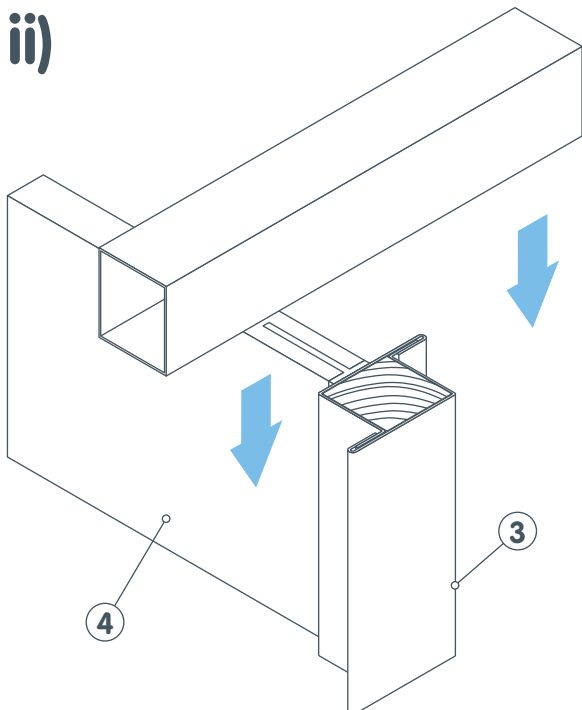
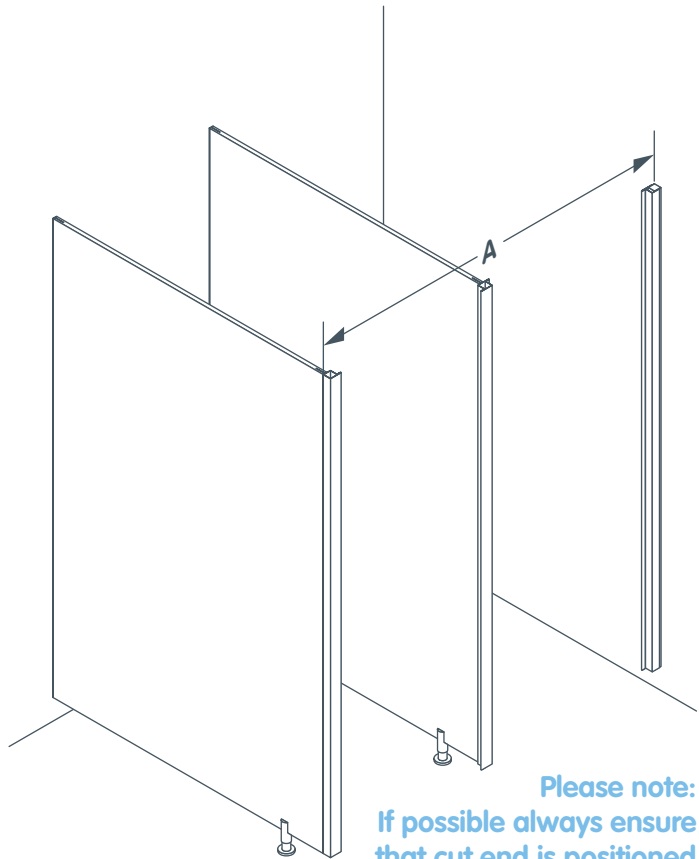

6

1. Headrail
2. Circular Saw
3. Pilaster
4. Partition
5. Drill 4mm dia. hole into pilaster wooden insert
6. No. 10 x 75mm round head screw

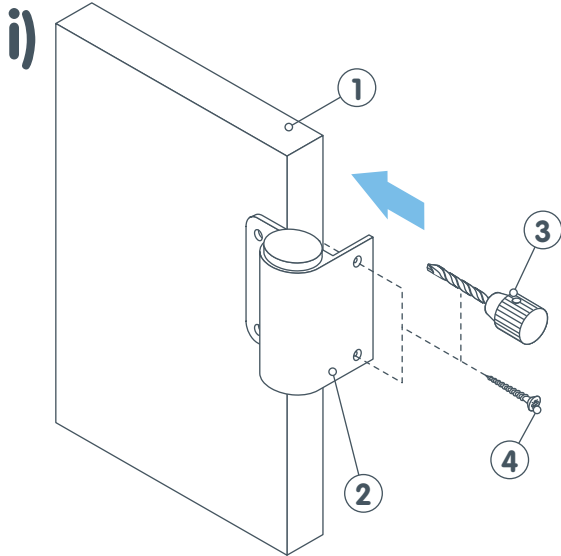

For Inward Opening Doors:
Fix hinge to inside face of door (see fig. A)

For Outward Opening Doors:
Fix hinge to outside face of door (see fig. B)

Fig A. Inward Opening Door Hinge

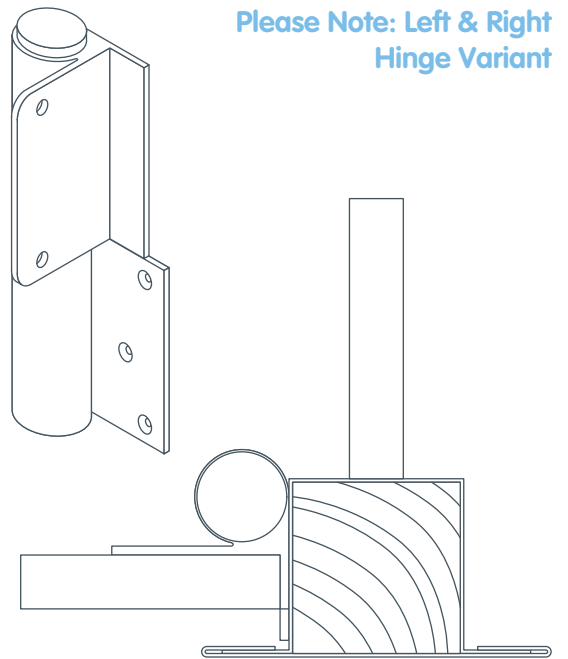
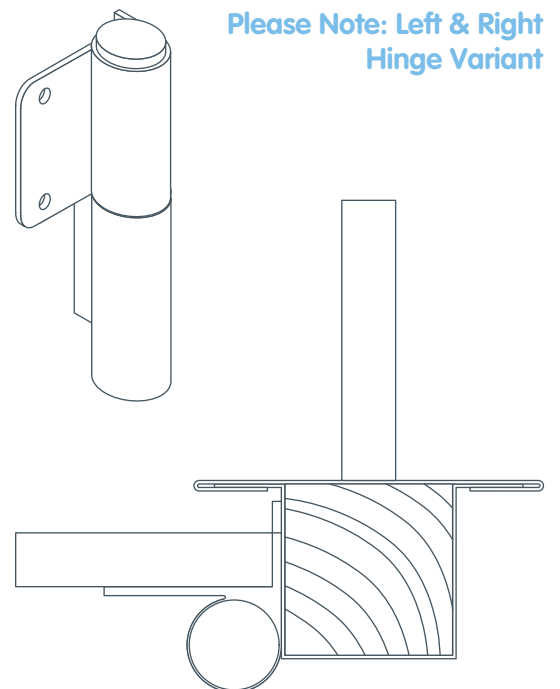
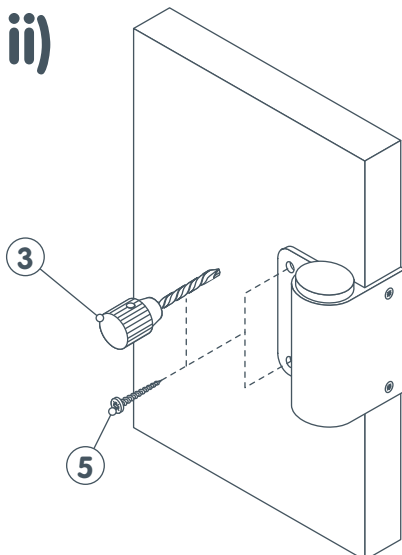

Fig B. Outward Opening Door Hinge



7



1. Door
2. Hinge top
3. Drill 2mm dia. pilot holes
4. No.8 x 1" csk screws
5. 20mm flange head screws

SGL Hinge Fixing Details

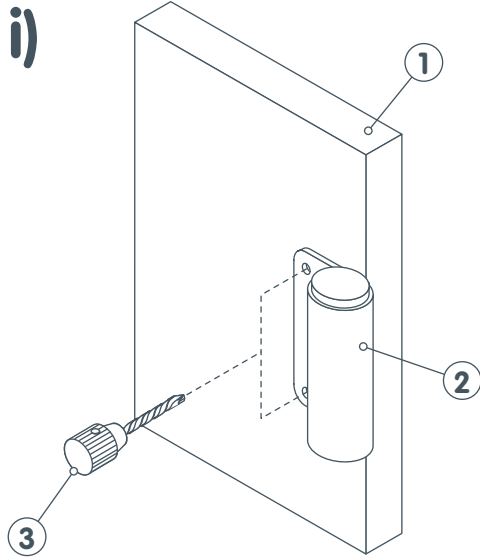

For Inward Opening Doors:
Fix hinge to inside face of door

For Outward Opening Doors:
Fix hinge to outside face of door

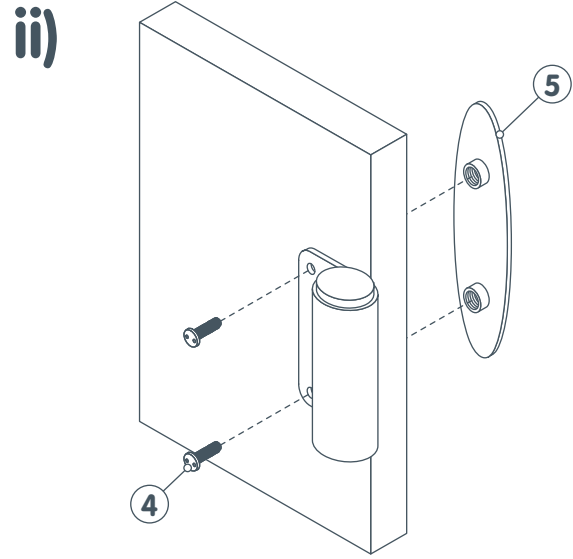

1. Door
2. Hinge top
3. Drill 5mm dia. holes
4. M5 x 10mm snake eye screws
5. Through fixing plate

7

Door Fixing Details

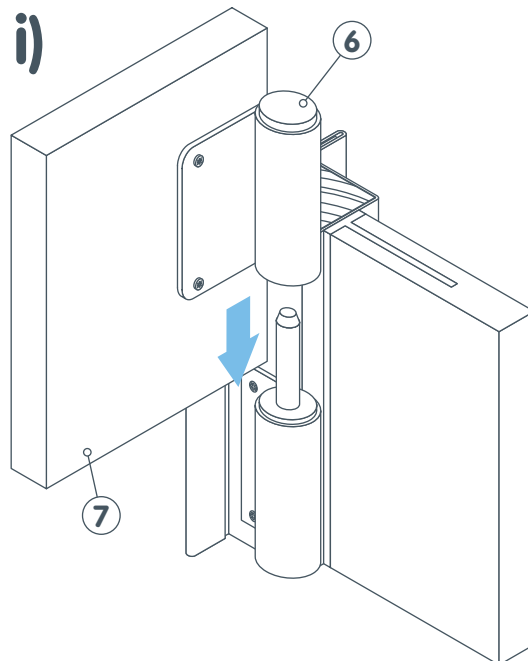
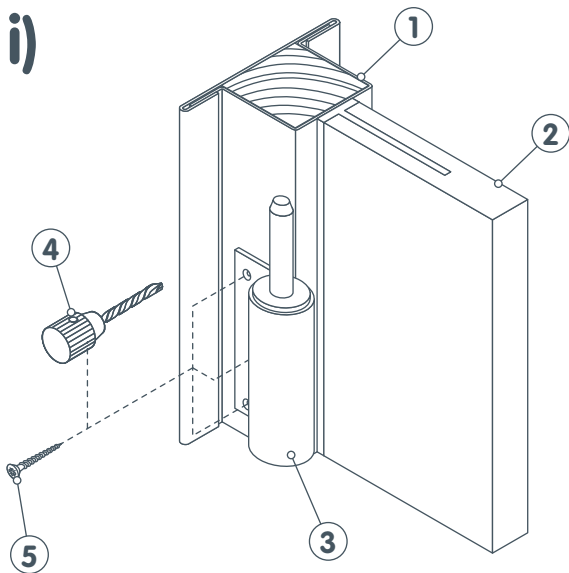

1. Pilaster
2. Partition
3. Hinge body
4. Drill 3mm dia. holes
5. No.8 x 2" csk screws
6. Hinge top
7. HPL/SGL door

8

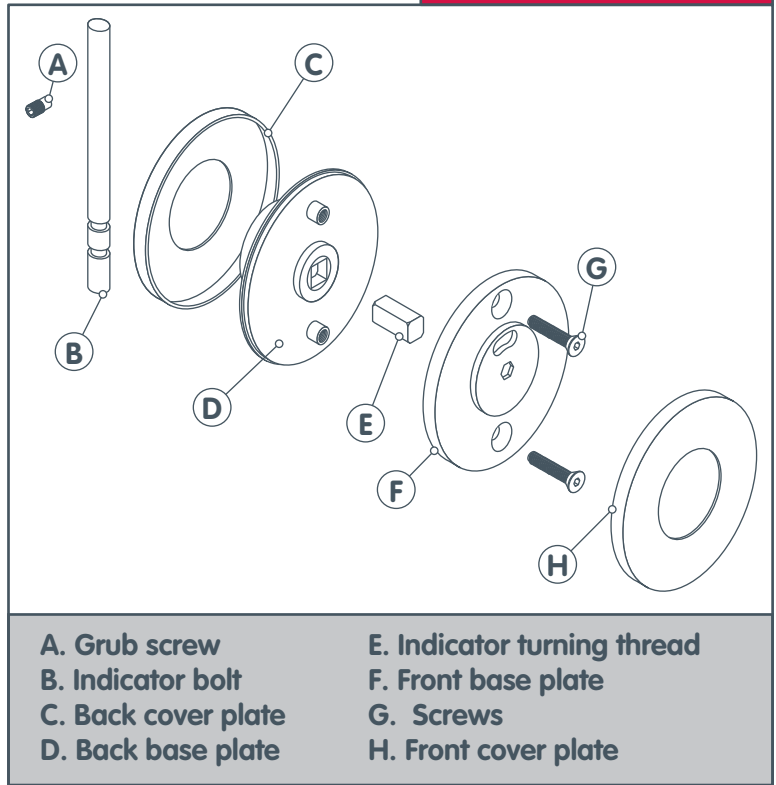
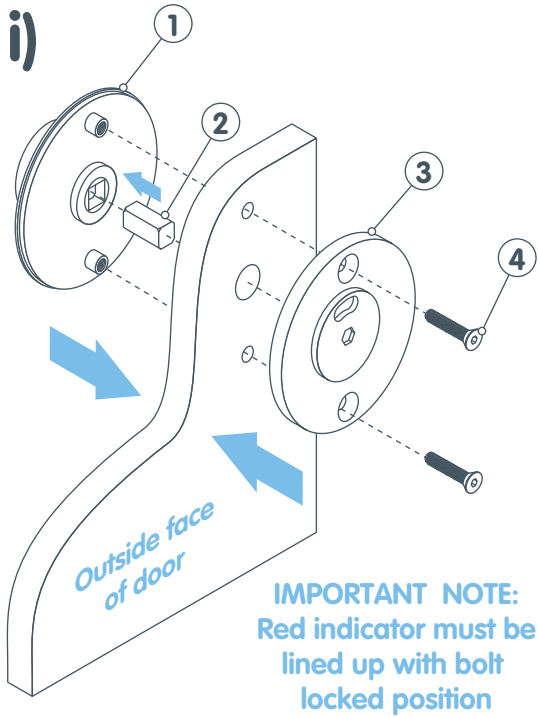

9

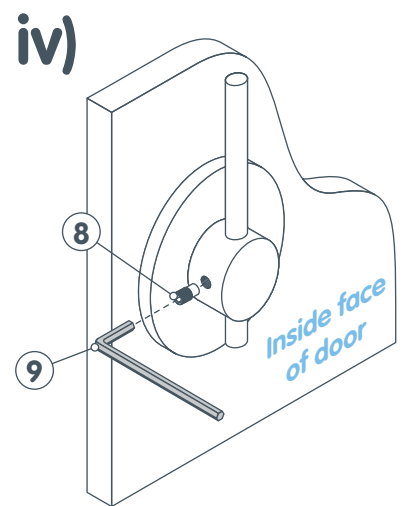
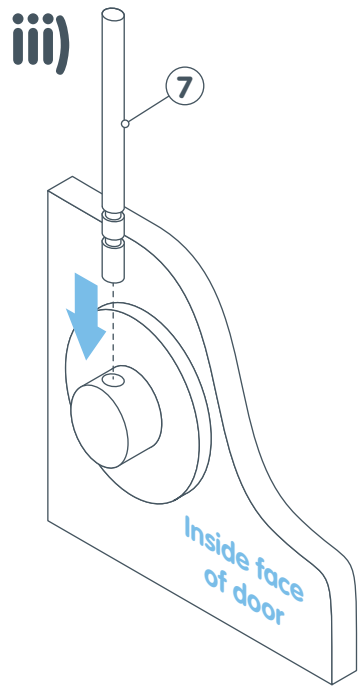
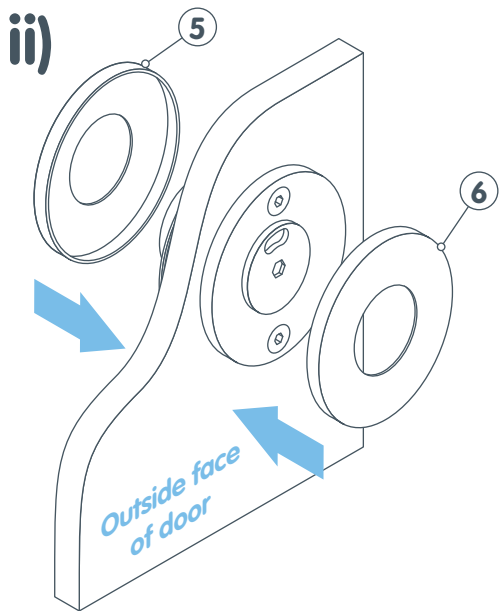

1. Back base plate
2. Indicator turning thread
3. Front base plate
4. Screws
5. Back cover plate
6. Front cover plate
7. Indicator bolt
8. Grub screw
9. Allen key

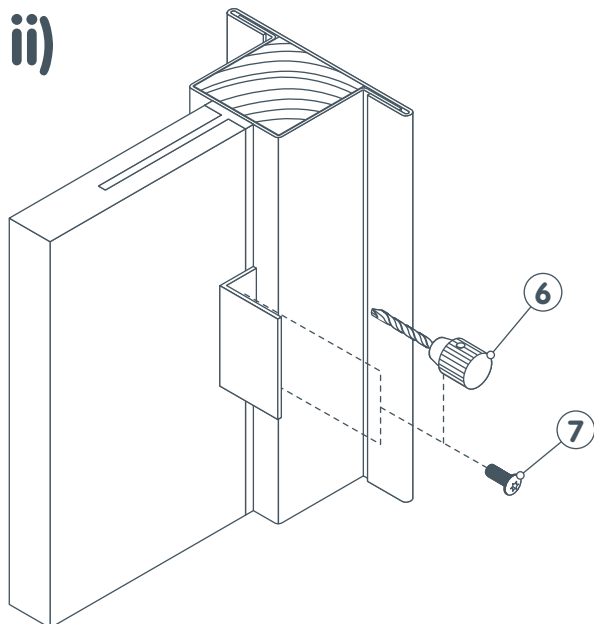
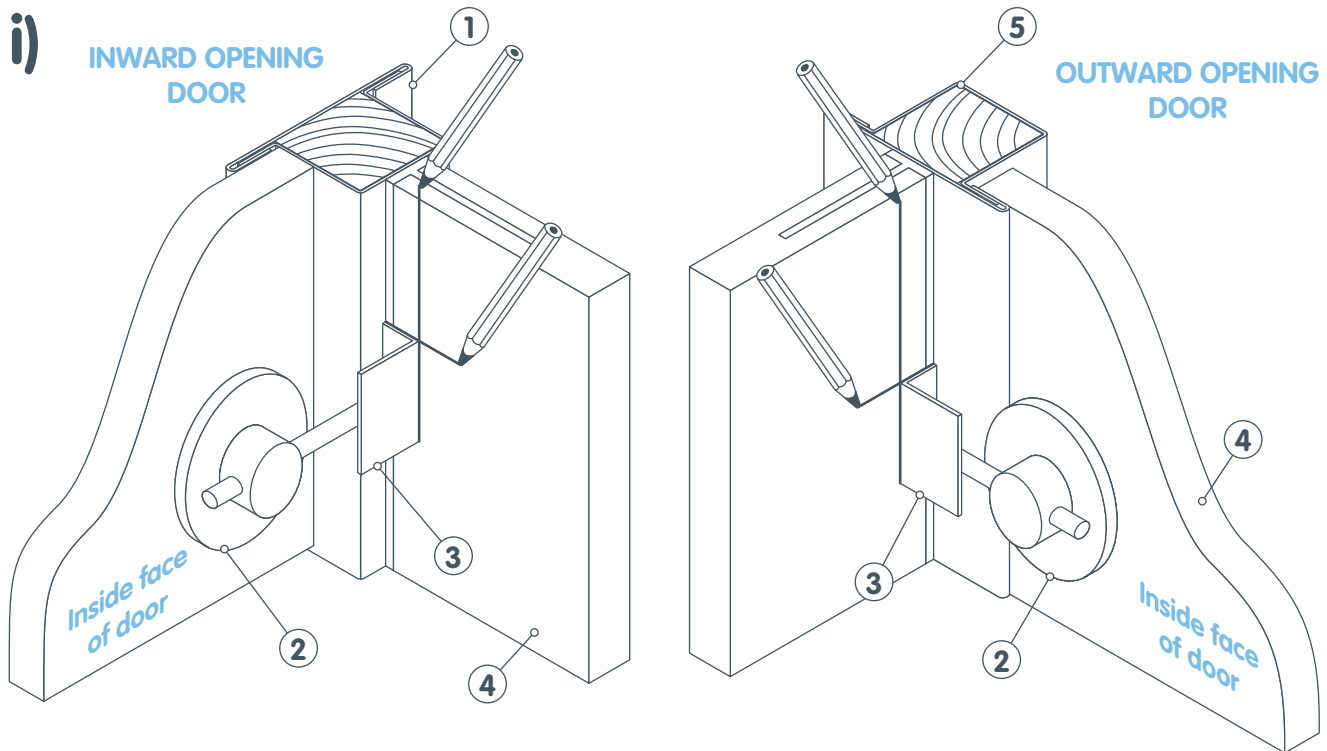

10

1. Inward opening door pilaster
2. Assembled indicator bolt
3. Keep for intermediate pilasters
4. Partition
5. Outward opening door pilaster
6. Drill dia. 3mm pilot holes
- 7a. 19mm torx head screws (HPL only)
- 7b. 12mm torx head screws (SGL only)

i)

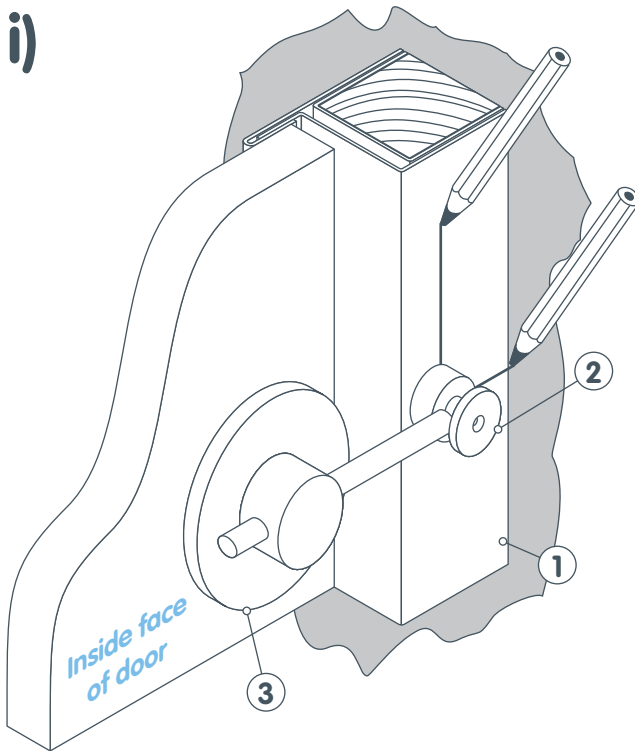

Front View

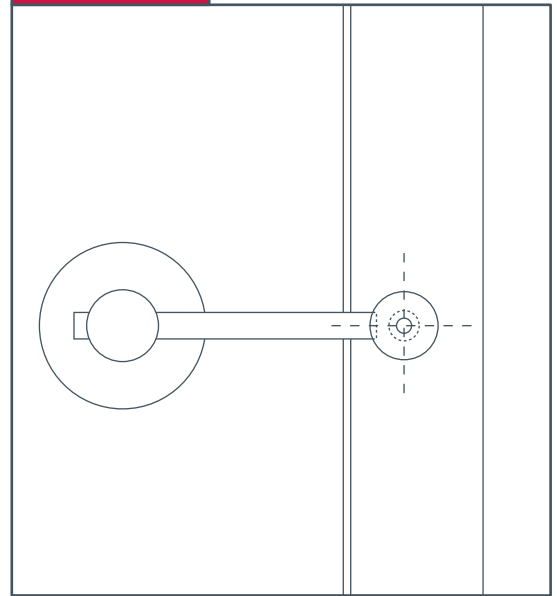

11

ii)

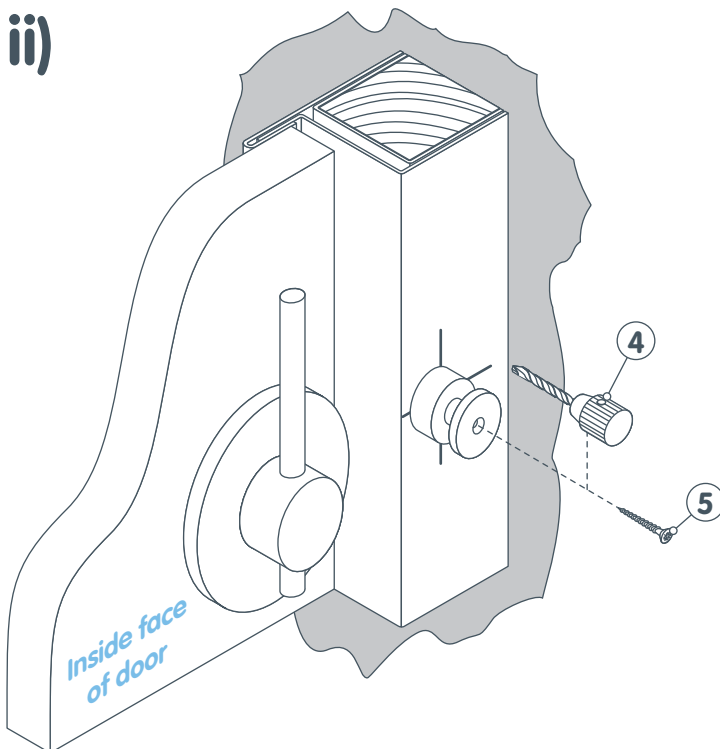

1. Wall end pilaster
2. Keep for wall end pilasters
3. Assembled indicator bolt
4. Drill 2.5mm dia. hole
5. No.8 x 1" csk screw

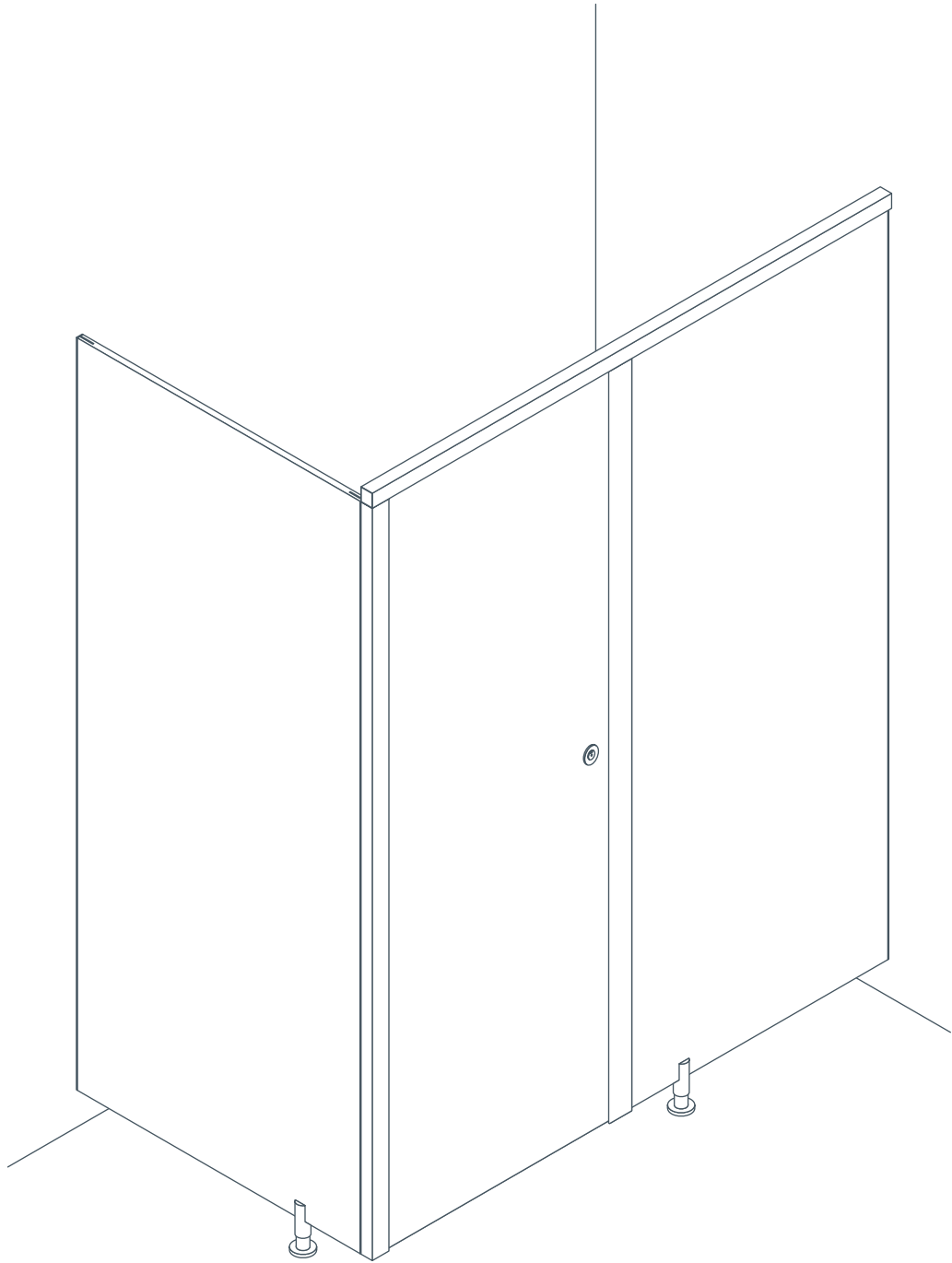

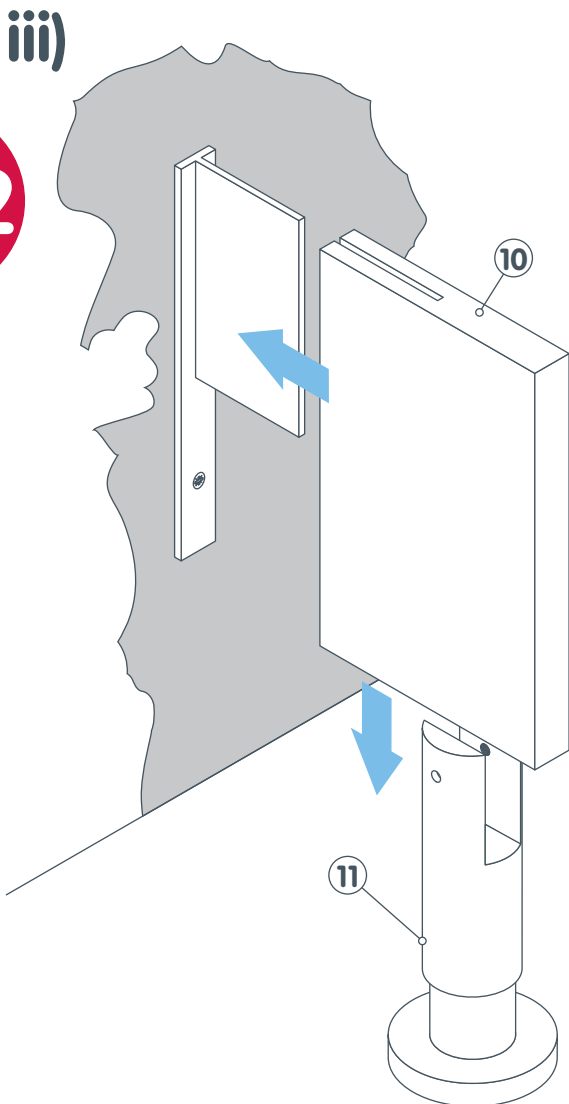
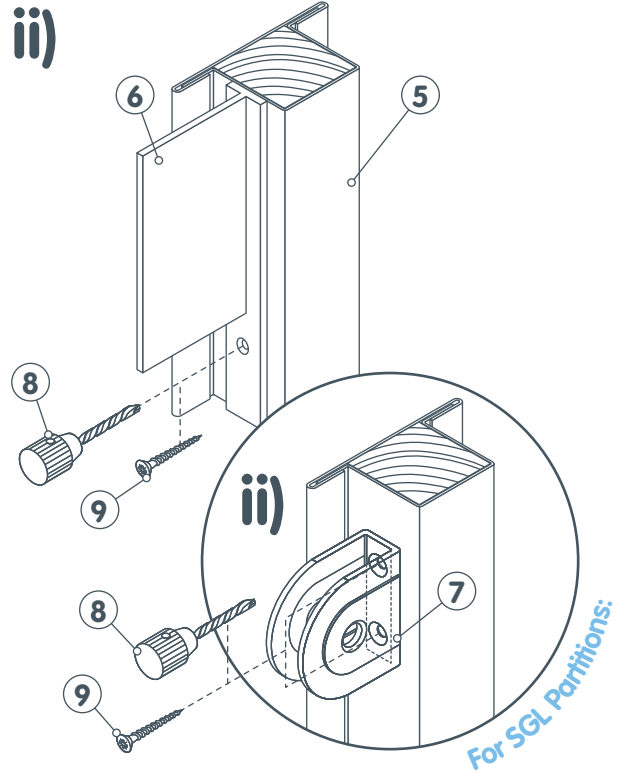
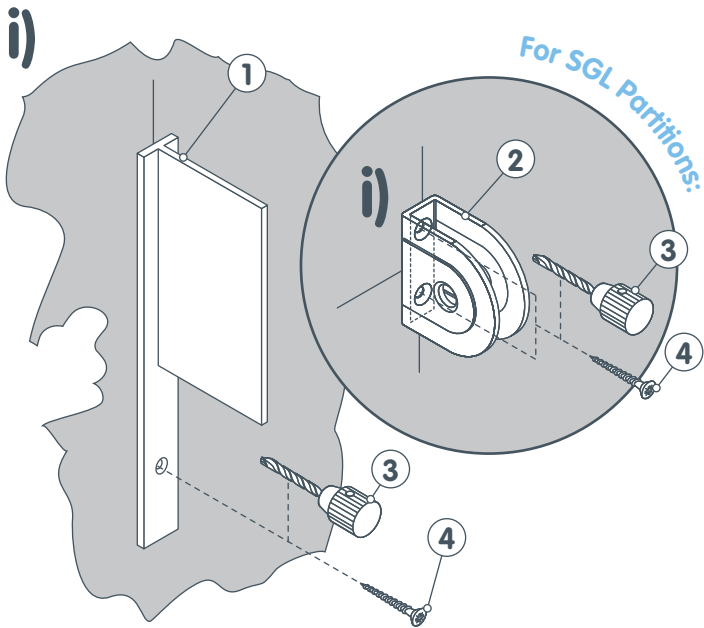

12

1. Wall end t-section
2. Wall end channel bracket
3. Drill to suit wall type
4. No. 8 x 2" csk screws
5. Intermediate pilaster
6. Intermediate t-section
7. Intermediate channel bracket
8. Drill 3mm dia. pilot hole
9. No. 8 x 1" csk screws
10. In-line partition
11. Pedestal

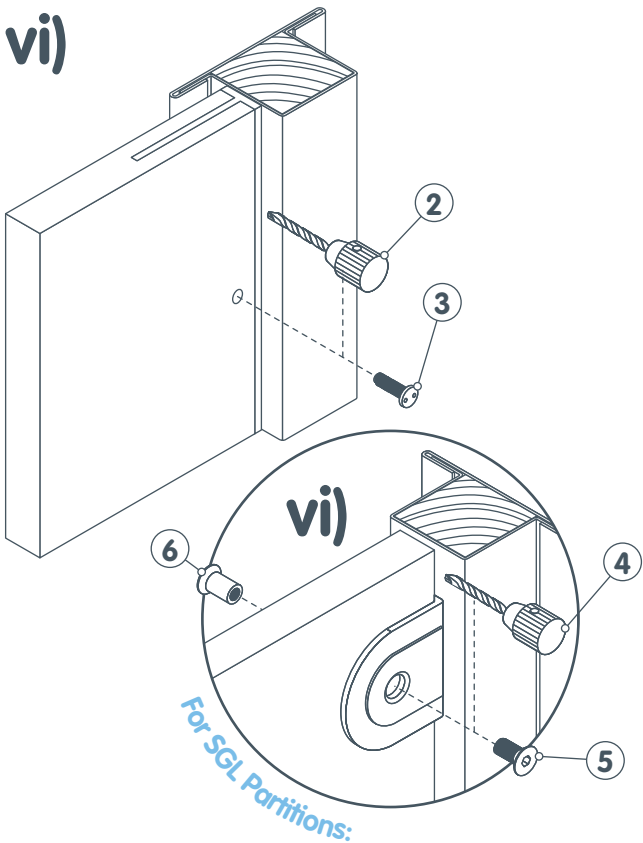
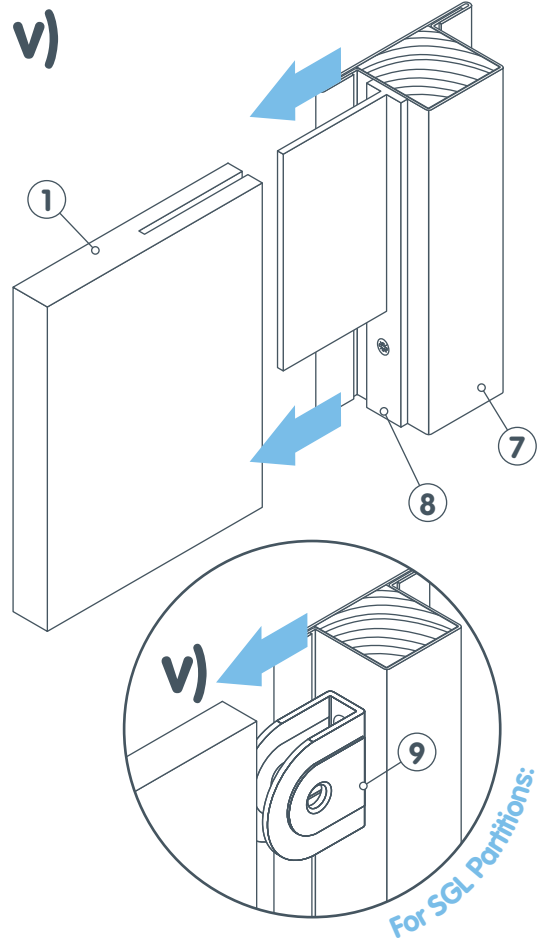
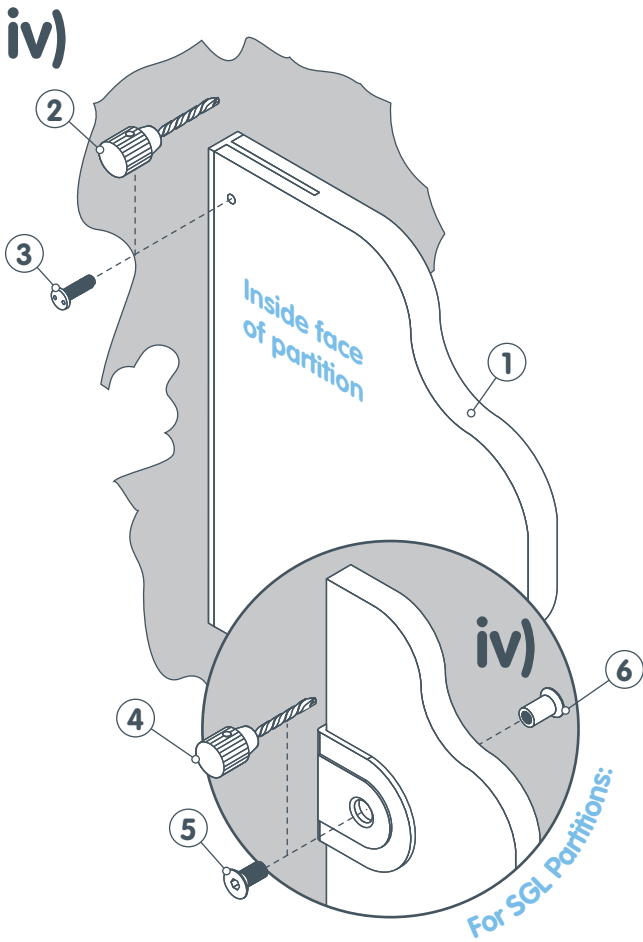

1. In-line partition
2. Drill 5mm dia. holes 13mm deep (to line up with holes in T-section)
3. M5 x 12mm snake eye screws
4. Drill 8mm dia. through holes
5. M6 x 14mm csk socket stainless steel screw
6. Multirol barrel
7. Intermediate pilaster
8. T-section
9. Channel bracket

www.amwell-systems.com

**Amwell Systems Ltd
Buntingford Business Park
Baldock Road
Buntingford
Herts
SG9 9ER
England**

**T +44 (0)1763 276200
F +44 (0)1763 276222
contact@amwell-systems.com**