

Cleaning & Maintenance

Cleaning Laminate Components:

Always start by trying the gentlest method of cleaning. If a stain persists, work through the following steps, repeating each step several times if the stain seems to be disappearing.

Step 1: For routine cleaning, use a damp cloth or sponge and a mild soap or detergent. Rinse the panels and dry on completion.

Step 2: For difficult stains apply a mild household cleaner detergent with a soft bristled brush.

Step 3: If stubborn stains persist, use a non-scratch cleaner scrubbing lightly with a soft bristled brush for 10 to 20 seconds.

Step 4: If a stain persists, apply undiluted household bleach, let it stand for no longer than 2 minutes, and rinse thoroughly with warm water. **DO NOT** expose the laminate surface to household bleach for prolonged periods of time, as this may lead to permanent discolouration.

Step 5: If the surface has been discoloured through long expose to industrial grime, clean carefully with a cream cleaner containing a mild abrasive.

DO: Always rinse thoroughly after cleaning (residue from cleaning solutions is the single greatest cause of damage to laminate surfaces).

DO: Wipe up spills immediately, and rinse thoroughly.

DO NOT: use acidic or abrasive cleaners, expose the laminate to household bleach for prolonged periods of time, or apply excessive scrubbing, especially on gloss finish surfaces.

Cleaning Ironmongery:

Powder Coated products should be cleaned at no more than three month intervals. Detergent diluted with warm water should be used. A soft cloth, natural sponge or a soft bristle brush may be used. Abrasive materials should be avoided. White spirit may be used to remove oil or grease deposits, but strong solvents must be avoided. The coated items must be thoroughly rinsed following the use of detergents.

Metallic surfaces should be cleaned as detailed for powder coating. Care should be taken in order avoid scratching the metallic surface.

Maintenance of Ironmongery

Cubicle locks and hinges should be wiped clean. A moderate amount of silicone type lubricant (such as WD40) should be applied periodically to all moving parts, with any excess promptly removed. Excess use of lubricants may attract dust, which will increase the wear rate of moving parts. It is imperative that the amount of lubricant is kept to a minimum. All fixing bolts etc. should be checked periodically and tightened as required.

General Comments:

In order to avoid water marks/ lime scale build up, standing water should be removed from horizontal surfaces. Any water that has splashed onto a panel edge should be removed immediately.

Recommendations for 12.5mm Solid Grade Laminate

Machining

- The machining of Compact laminate should be done using tungsten carbide tipped blade/ cutters or metal cutting tools.

Cutting

- In order to obtain a clean cut, we suggest the use of carbide tipped saw blades with trapezoidal and as many teeth as possible or a jigsaw with a metal cutting blade. However, alternating teeth can be equally suitable, but the cut will not be as clean.
- Best results can be obtained with horizontally fixed saws.

Precision Cutting

- A clean edge without flaking can be obtained. The best quality cut can be obtained by firstly, sawing the panel slightly oversize and then re-cutting the edge to the precise measurement using a tungsten carbide tipped router cutter of the required profile running at 18,000 to 22,000 rpm.

Grooving

- Compact can be grooved using a saw blade or router cutter with tungsten carbide tips.
- The depth of the groove must not exceed 1/3 of the Compact thickness.

Drilling

- Carbide bits with 3 prongs give best results (helical bits) and can be used in preference to high-speed steel drills.
- Holes can be drilled through part of the thickness or through the whole. In the case of stopped holes, a minimum thickness of 1.5mm to 2mm of the laminate must remain (i.e. maximum depth of hole = 11mm). A minimum of 1mm of space must remain between the tenon, screw tip or insert and the bottom of the hole (otherwise there is a risk of the laminate cracking when fitting)
- Pilot hole diameters for self tapping screws are: 3.5mm - No.6 screw; 3.5mm - No.8 screw; 4.5mm - No.10 screw; 5mm - No.12 screw.

Cut-Outs

- Square Cut-outs:- Drill the four corners with at least a 10mm diameter hole and, starting from one of the holes, use a jigsaw with a metal cutting blade, cutting in straight lines, join the holes and square into the corners. Finish with a metal file (semi-soft), ensuring that all sharp arises are removed to avoid injury.
- Oval or Circular Cut-outs:- For example, cutting a basin hole into a vanity top. Drill a single 10mm diameter hole and, starting from the hole, cut according to template using a jigsaw with a metal cutting blade. Finish with a metal file (semi-soft), ensuring that all sharp arises are removed to avoid injury.

Resizing and re-edging previously finished SGL panels

- We would recommend that you cut the panel as previously described and trim to size using a 'TREND' Sunk Bead Router Cutter running at 18,000 to 22,000 rpm and finish with a 300 grit sand paper.
- Polish as described below.

Finishing edges

- In order to eliminate machine-cutting imperfections created at the edges of the Compact, sand with a 300 grit sand paper to a fine finish.
- To obtain darker edges, rub the edge with a cloth soaked in linseed oil or wax. Leave to dry for 30 minutes and wipe off. Sharp edges must be smoothed to avoid injury.

* See Layout Drawing

1

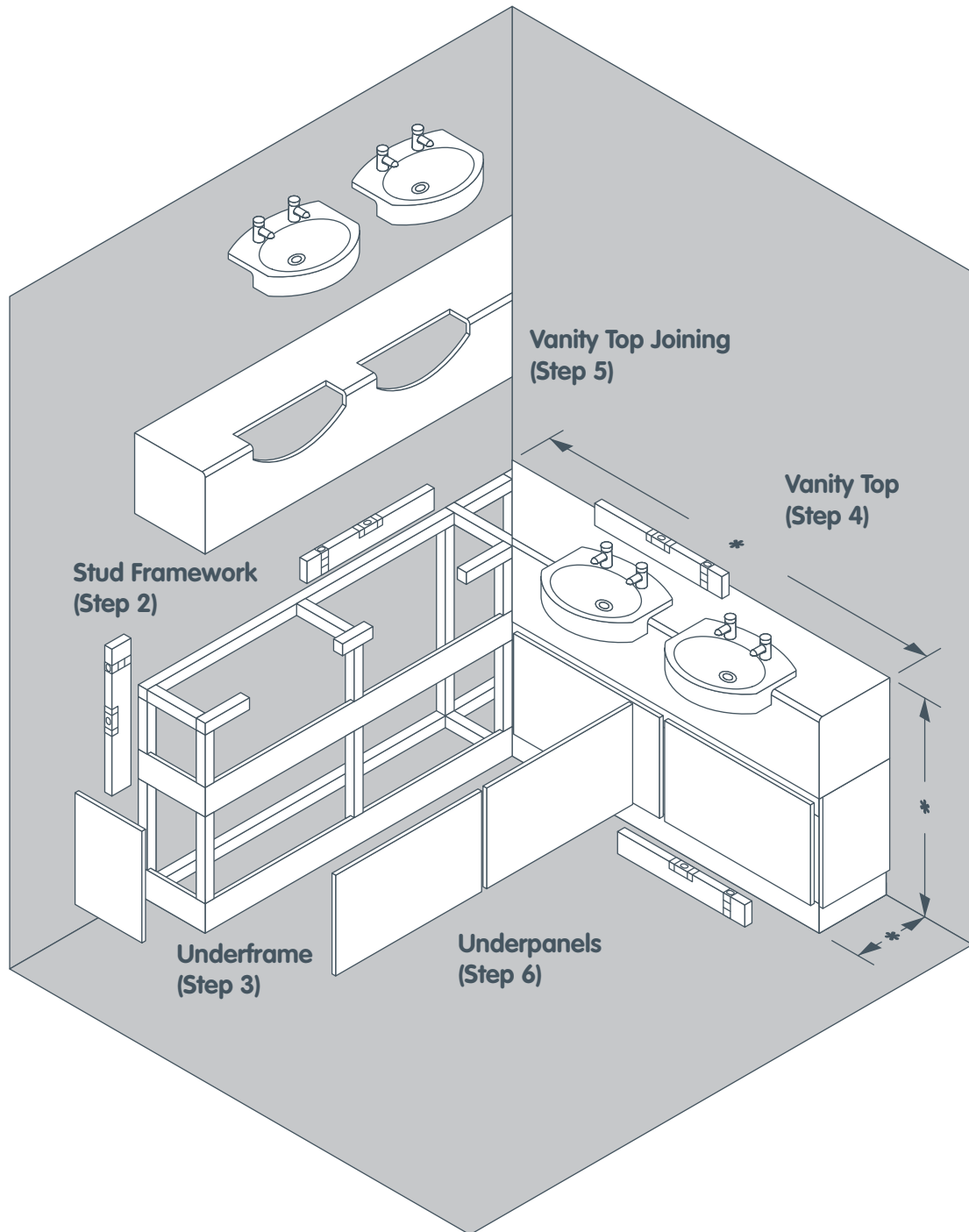

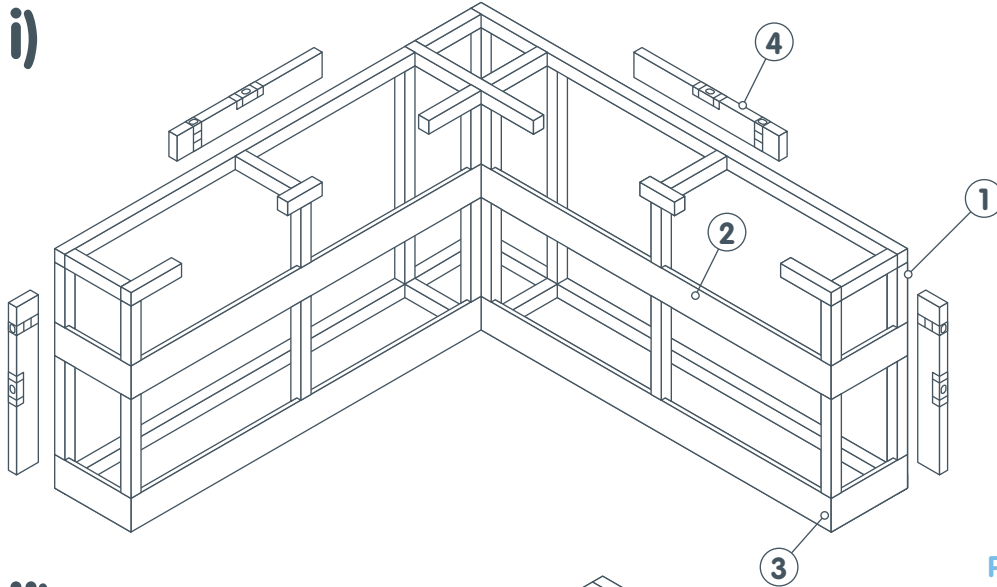

Please Note:
Laminate visible faces
of framework on site

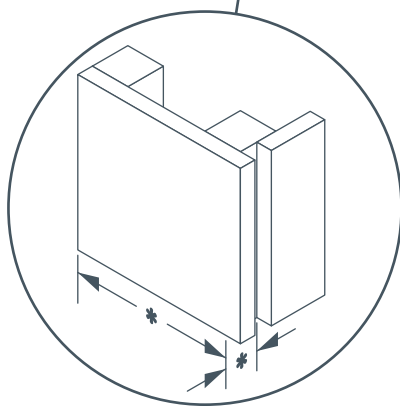
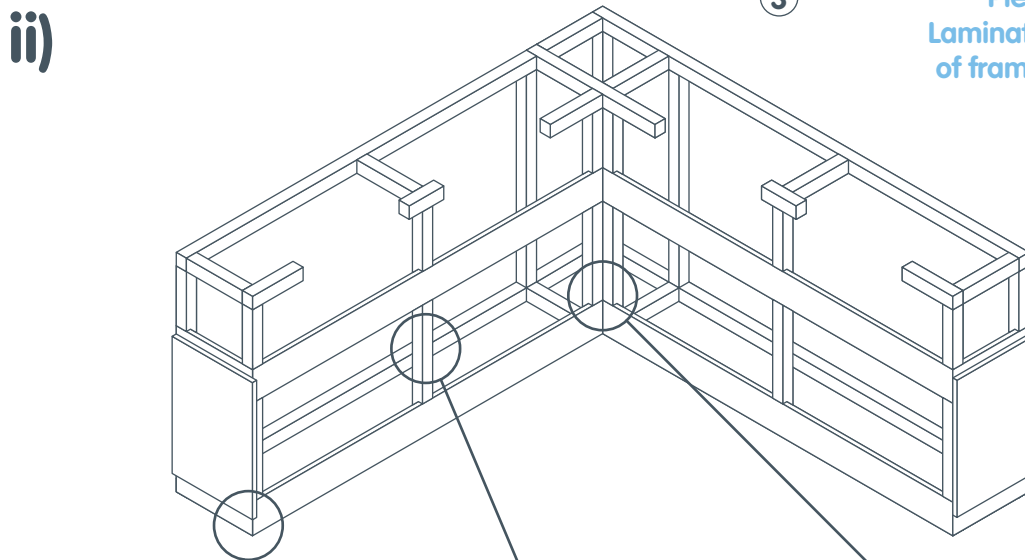

Return End

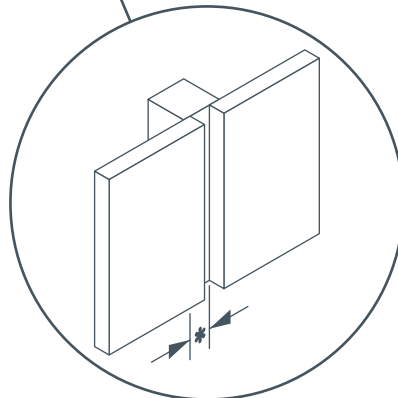

Panel to Panel

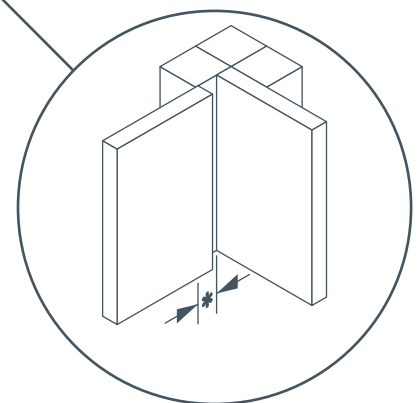

Panel to Panel
Corner

- 1. 44mm x 44mm softwood framework (front face laminated on site)
- 2. 110mm x 18mm framework (front face laminated on site)
- 3. 110mm x 18mm MDF or plywood skirting (finish by others)
- 4. Spirit Level

* See Layout Drawing

i) Build underframe:

- Use 44mm x 44mm timber & 110mm x 18mm for skirting and horizontal flashgap
- Laminate must be bonded to visible front faces

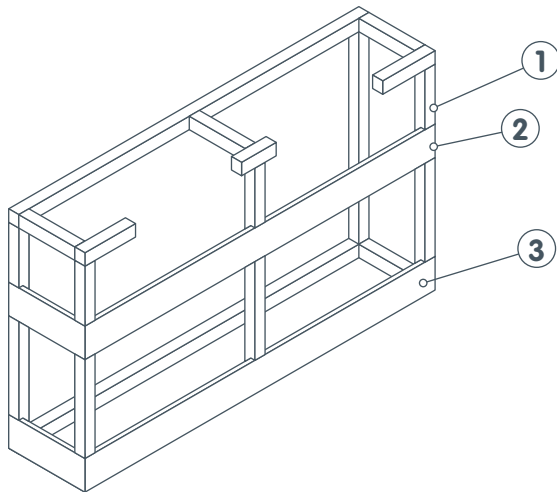

ii) Return end panel fixing:

- Cut return end panel to suit
- Fix end panel from behind with suitable screws

3

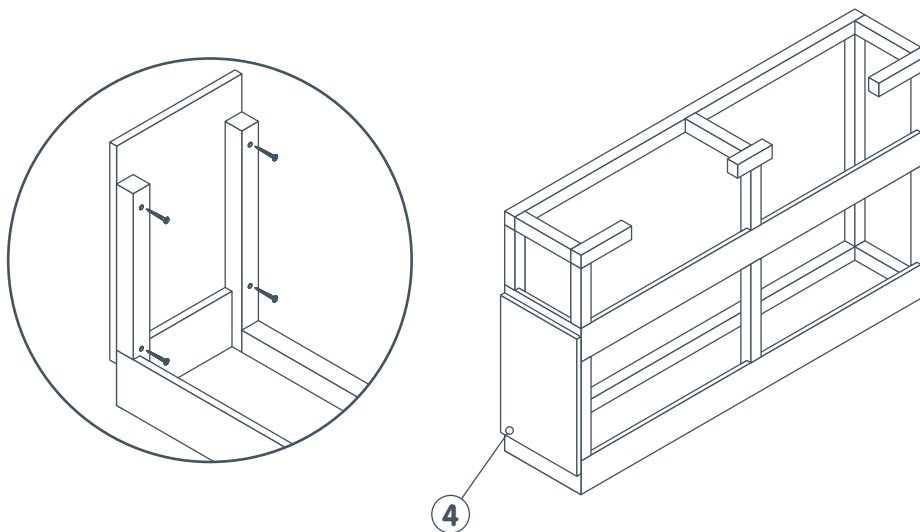

1. 44mm x 44mm softwood framework (front face laminated on site)
2. 110mm x 18mm framework (front face laminated on site)
3. 110mm x 18mm MDF or plywood skirting (finish by others)
4. Return end panel

- i) Cut out vanity top to suit vanity basin:
• Use template supplied with basin

- ii) Fix and secure vanity top to stud framework

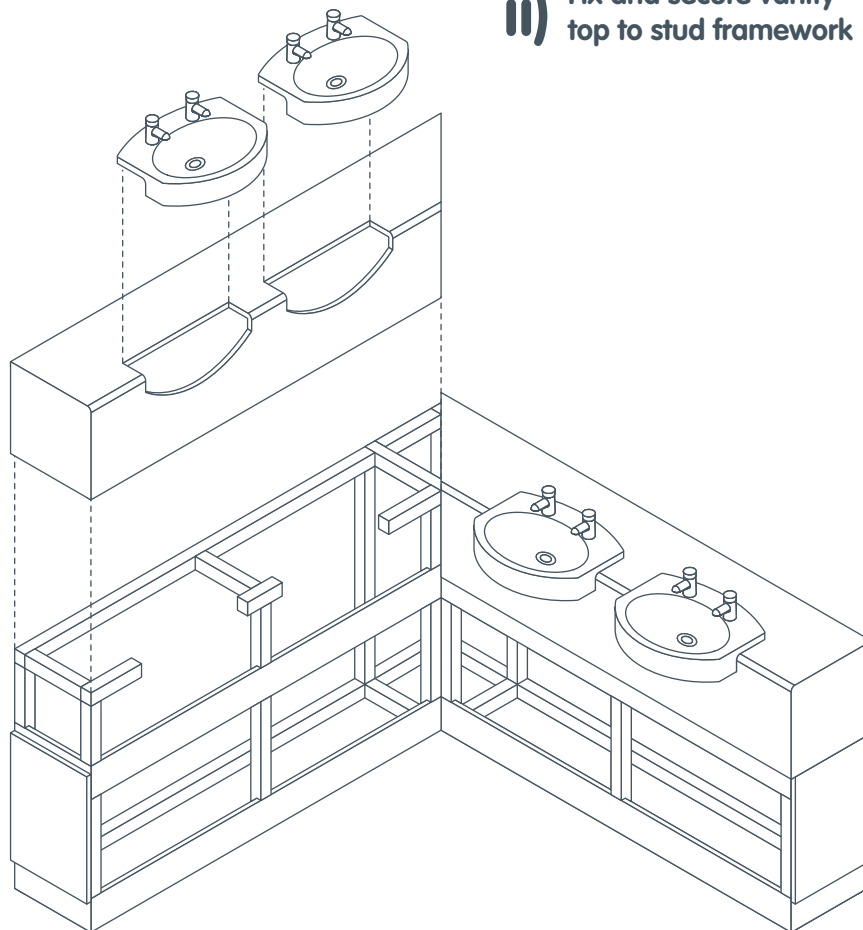

- iii) Fix and seal vanity basins to top
(by others)

Please Note:
If vanity top requires a joint please refer to step 5

HPL Vanity Top Joining & Fixing Details

- i) Cut out vanity top to suit basins:
 - Use template supplied with basin
 - DO NOT fix basins at this stage
- ii) Join the vanity top:
 - Apply appropriate sealant to lamello cut outs and both edges of the vanity top
- iii) Insert draw bolt and bring tops together by screwing the nut on the draw bolt

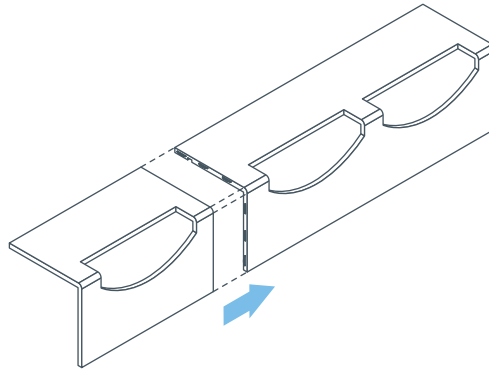

5

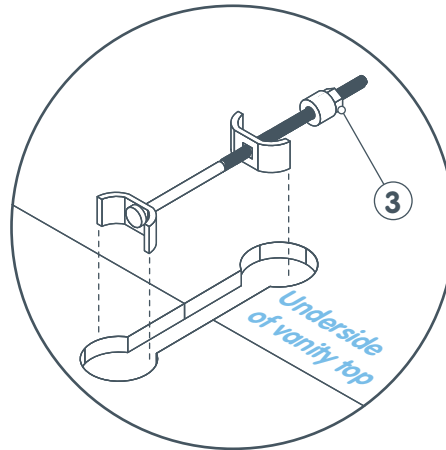
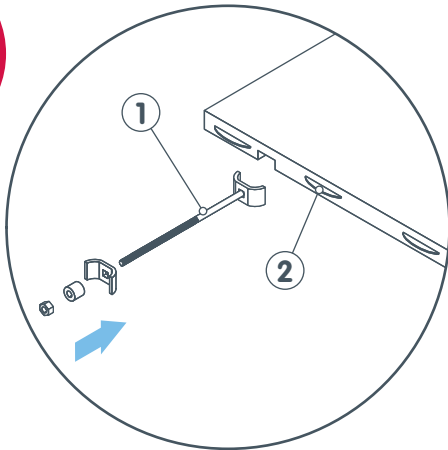

- iv) Remove excess glue/sealant

1. Draw bolt
2. Lamello cut-outs
3. Draw bolt nut

SGL Vanity Top Joining & Fixing Details

- i) Cut out vanity top to suit basins:
 - Use template supplied with basin
 - DO NOT fix basins at this stage
- ii) Join the SGL Vanity Top:
 - Apply an appropriate sealant or silicone to both edges of the vanity top & apron
- iii) Bring the top together by fixing through the aluminium plate & on to the underside of the pre-drilled holes in the underside of the top

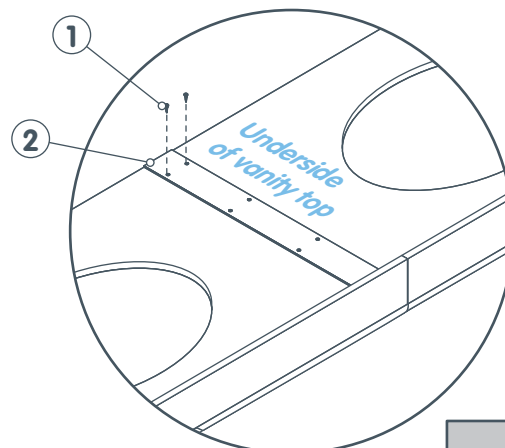
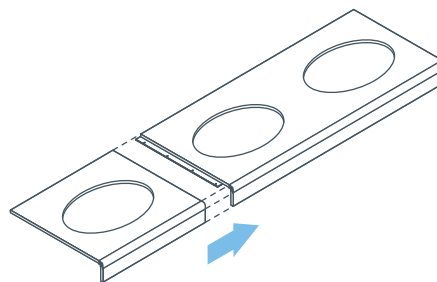

- iv) Remove excess glue/sealant

1. No. 8 x 3/4" pozi screws
2. Aluminium plate

i) Place panel in required position and level against underframe open space

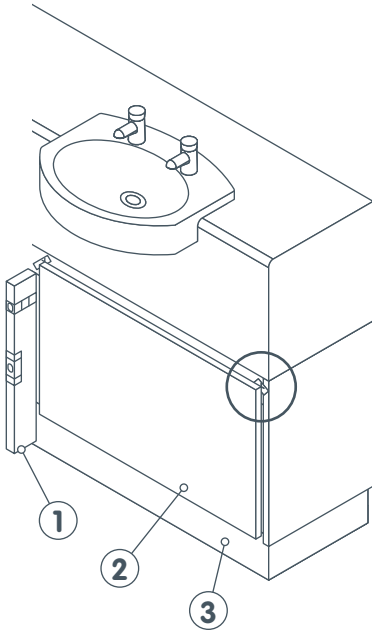

ii) Mark panel top corner points on outside face of underframe (mark on masking tape for surface protection & easier viewing)

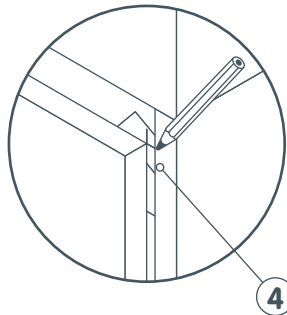

iii) Decide what distance to attach fixing clips from top of panel

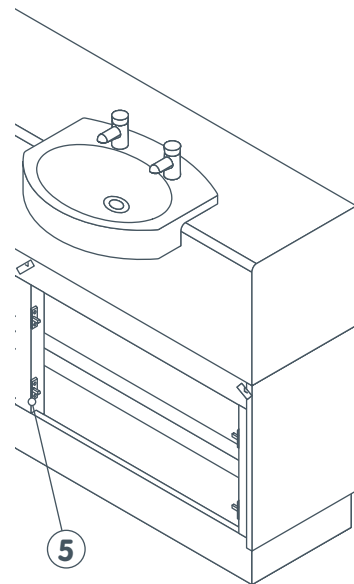
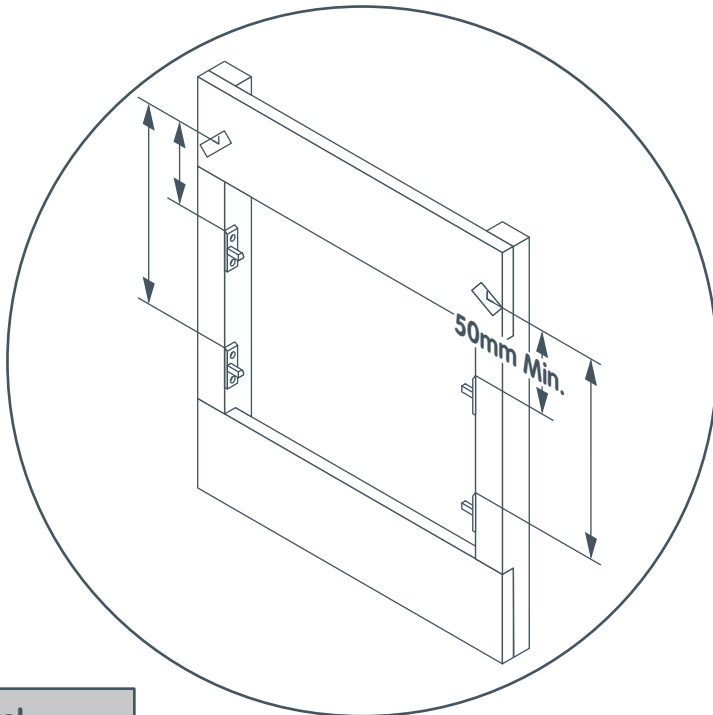

Please note: Fixing clips should be evenly spaced & consistent for each side of the underpanel

- 1. Spirit level
- 2. Underpanel
- 3. Underframe
- 4. Masking tape
- 5. Fixing clips

iv)

Fix clips to inside edge of underframe:

- Hand tighten - DO NOT use power drill
- Fixing clip distances should be evenly spaced & constant for each side of the panel

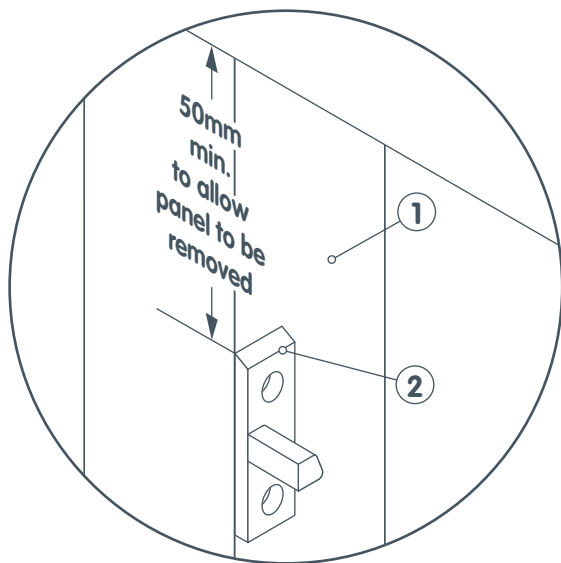

6

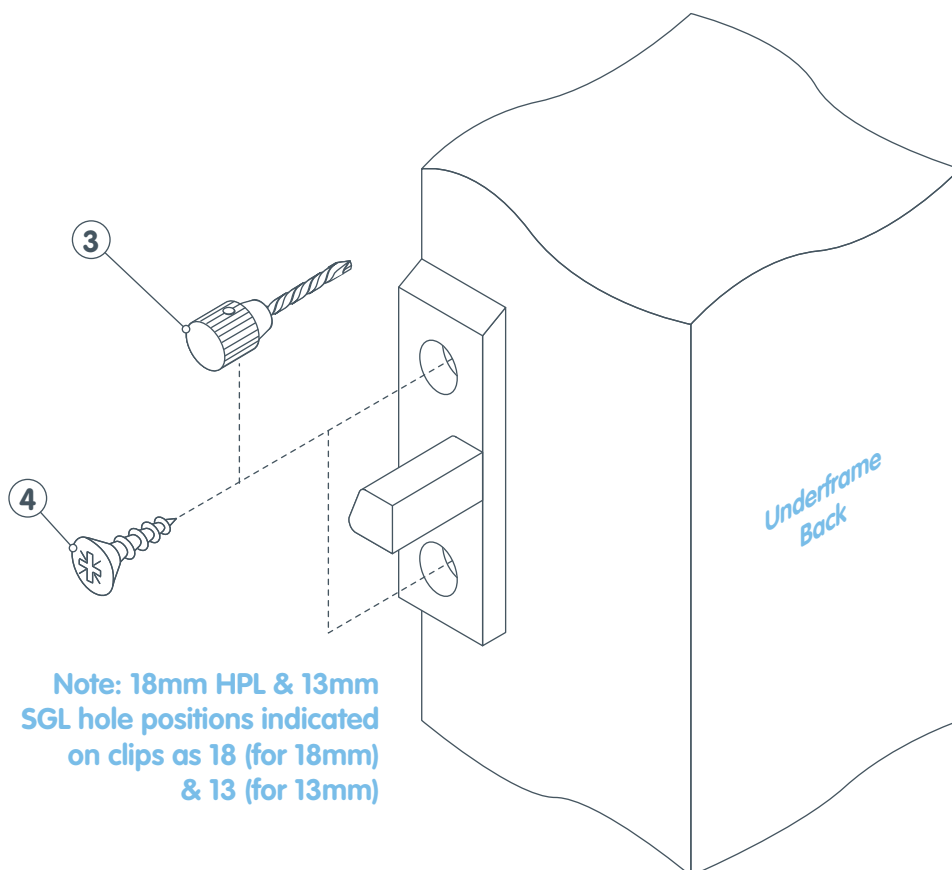

Note: 18mm HPL & 13mm SGL hole positions indicated on clips as 18 (for 18mm) & 13 (for 13mm)

1. Underframe
2. Lower fixing clip
- 3a. 2mm dia. pilot hole, max. 17mm deep (HPL only)
- 3b. 3.5mm dia. pilot hole, max. 11mm deep (SGL only)
4. No. 8 x 3/4" pozi csk screw

v)

Mark upper clip positions on inside face of front panel:

- They must correspond with those distances measured on the underframe

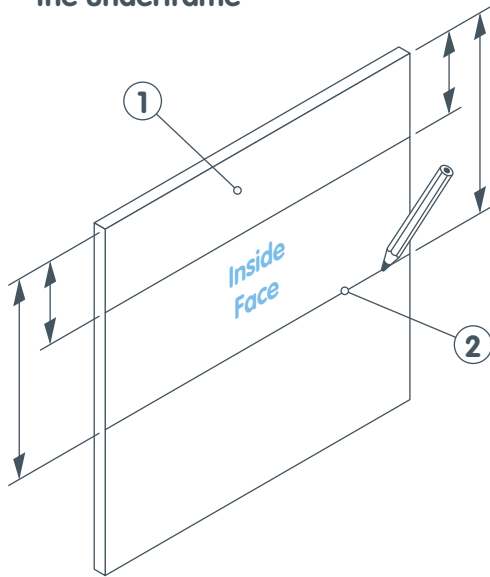

vi)

Fix upper clips to inside face of panel:

- Clips should be at overlap width plus 5mm from each panel edge
- The top of each clip should be 25mm up from the lines drawn

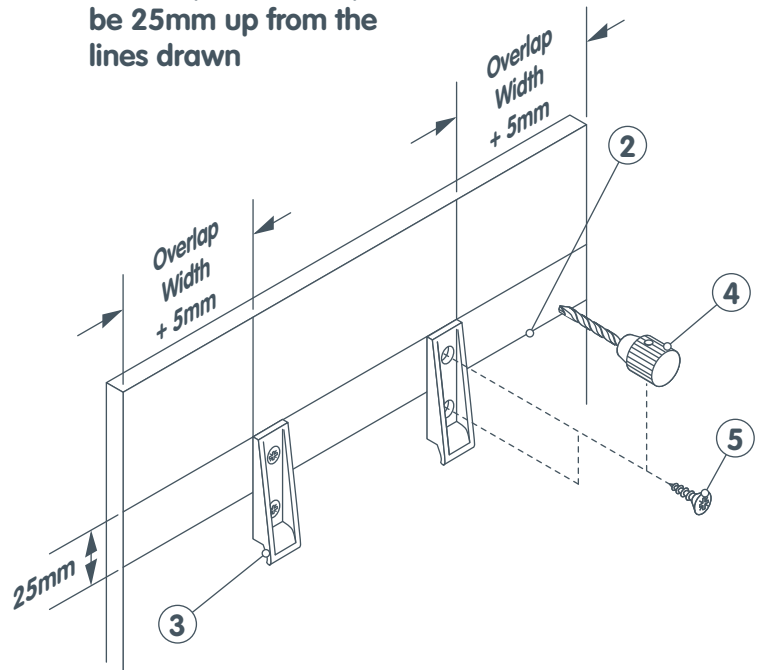

vii)

- Remove all masking tape
- Secure panel to underframe by pushing in & sliding down
- Upper & lower clips should then connect

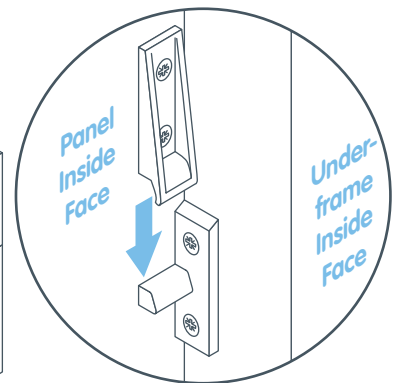
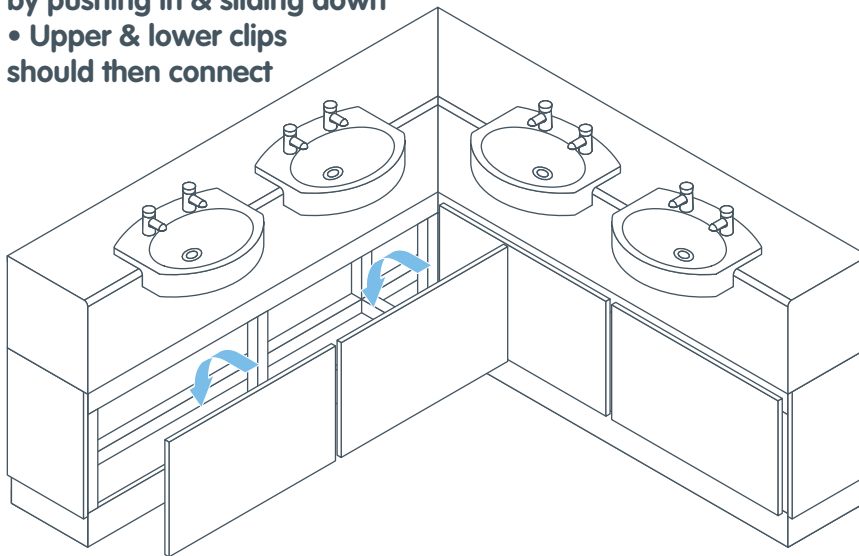

6

1. Front panel
2. Marked lines corresponding to marks for lower clips
3. Upper clips
- 4a. 3.5mm dia. pilot hole, 11mm deep (SGL only)
- 4b. 2mm dia. pilot hole, 17mm deep (HPL only)
- 5a. No. 8 x 1/2" pozi csk screw (SGL only)
- 5b. No. 8 x 3/4" pozi csk screw (HPL only)

www.amwell-systems.com

**Amwell Systems Ltd
Buntingford Business Park
Baldock Road
Buntingford
Herts
SG9 9ER
England**

**T +44 (0)1763 276200
F +44 (0)1763 276222
contact@amwell-systems.com**