











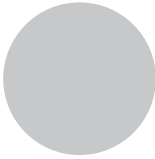

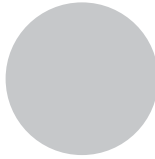

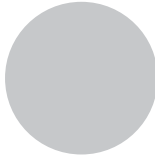
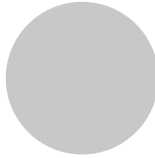
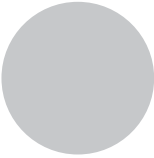
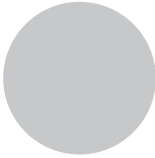
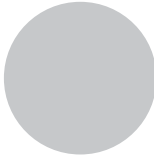
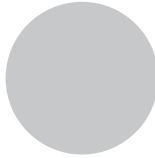

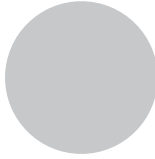









Amwell

Washrooms from concept to completion

Delivery Note Number:

					Fixing Instructions Impact	
						
						
						
						

Cleaning & Maintenance

Cleaning Laminate Components:

Always start by trying the gentlest method of cleaning. If a stain persists, work through the following steps, repeating each step several times if the stain seems to be disappearing.

Step 1: For routine cleaning, use a damp cloth or sponge and a mild soap or detergent. Rinse the panels and dry on completion.

Step 2: For difficult stains apply a mild household cleaner detergent with a soft bristled brush.

Step 3: If stubborn stains persist, use a non-scratch cleaner scrubbing lightly with a soft bristled brush for 10 to 20 seconds.

Step 4: If a stain persists, apply undiluted household bleach, let it stand for no longer than 2 minutes, and rinse thoroughly with warm water. **DO NOT** expose the laminate surface to household bleach for prolonged periods of time, as this may lead to permanent discolouration.

Step 5: If the surface has been discoloured through long expose to industrial grime, clean carefully with a cream cleaner containing a mild abrasive.

DO: Always rinse thoroughly after cleaning (residue from cleaning solutions is the single greatest cause of damage to laminate surfaces).

DO: Wipe up spills immediately, and rinse thoroughly.

DO NOT: use acidic or abrasive cleaners, expose the laminate to household bleach for prolonged periods of time, or apply excessive scrubbing, especially on gloss finish surfaces.

Cleaning Ironmongery:

Powder Coated products should be cleaned at no more than three month intervals. Detergent diluted with warm water should be used. A soft cloth, natural sponge or a soft bristle brush may be used. Abrasive materials should be avoided. White spirit may be used to remove oil or grease deposits, but strong solvents must be avoided. The coated items must be thoroughly rinsed following the use of detergents.

Metallic surfaces should be cleaned as detailed for powder coating. Care should be taken in order avoid scratching the metallic surface.

Maintenance of Ironmongery

Cubicle locks and hinges should be wiped clean. A moderate amount of silicone type lubricant (such as WD40) should be applied periodically to all moving parts, with any excess promptly removed. Excess use of lubricants may attract dust, which will increase the wear rate of moving parts. It is imperative that the amount of lubricant is kept to a minimum. All fixing bolts etc. should be checked periodically and tightened as required.

General Comments:

In order to avoid water marks/ lime scale build up, standing water should be removed from horizontal surfaces. Any water that has splashed onto a panel edge should be removed immediately.

Introduction

Impact offers the option of 20mm square edged pilasters with matching 1mm pvc lipping. Alternatively, for visual impact choose 20mm or 30mm thick pilasters with postformed soft curves to vertical edges.

Please assemble your impact cubicle system by referring to these installation instructions and the layout drawing supplied.

Prerequisites

Ideally cubicles should be installed onto a level surface; however splash cubicles offer an adjustable pedestal leg that can be adjusted +/- 10mm to accommodate some sloping floors.

When fixing to wall, please note the following:

Ensure the wall is structurally sound; provisions should be made in the event of studded walls.

In the event of a plasterboard fixing ensure that the post is fixed on to an appropriate timber stud.

Safety

Before holes are drilled into walls we suggest that a suitable detector is used to locate any hidden electrical and water services.

We advise the use of eye and ear protection whenever power tools are utilised.

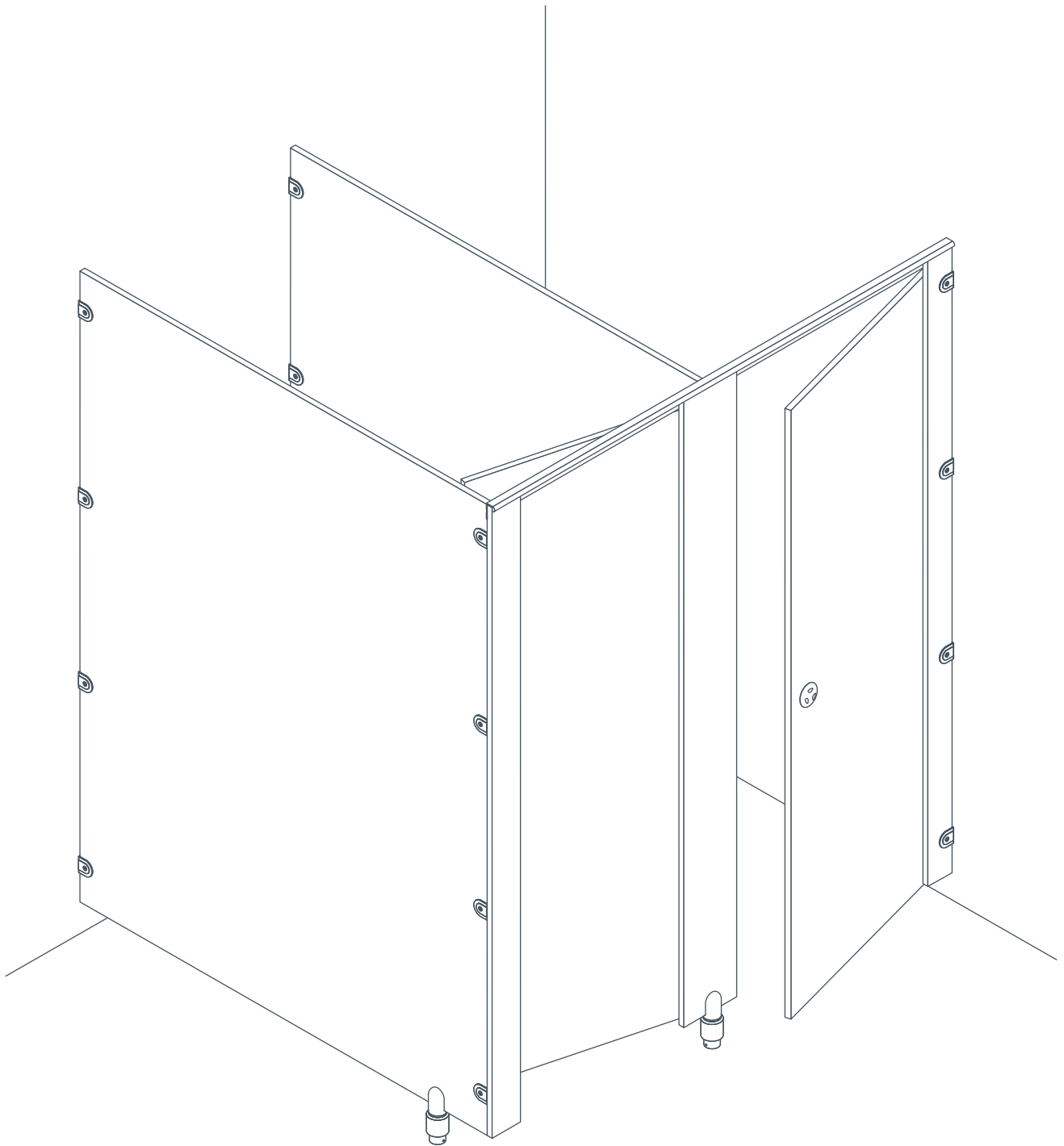

i)

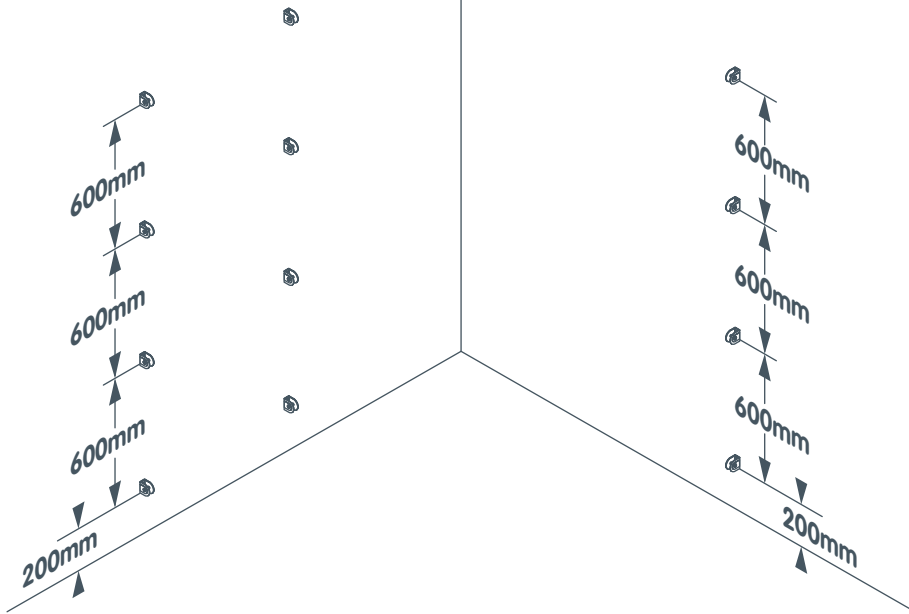

Please note: Ensure walls are level prior to installation.

ii)

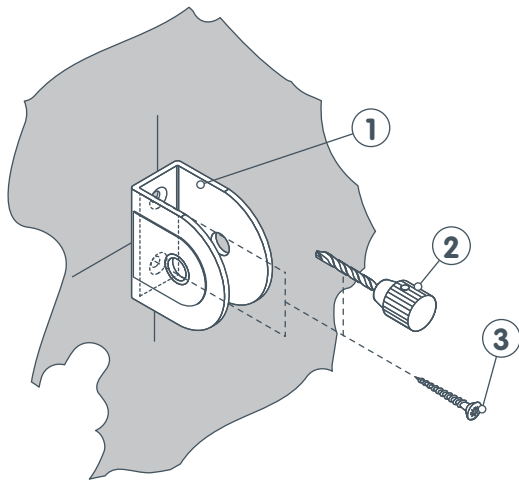

1. Channel bracket
2. Drill to suit wall type
3. 50mm x 5mm csk screw

i)

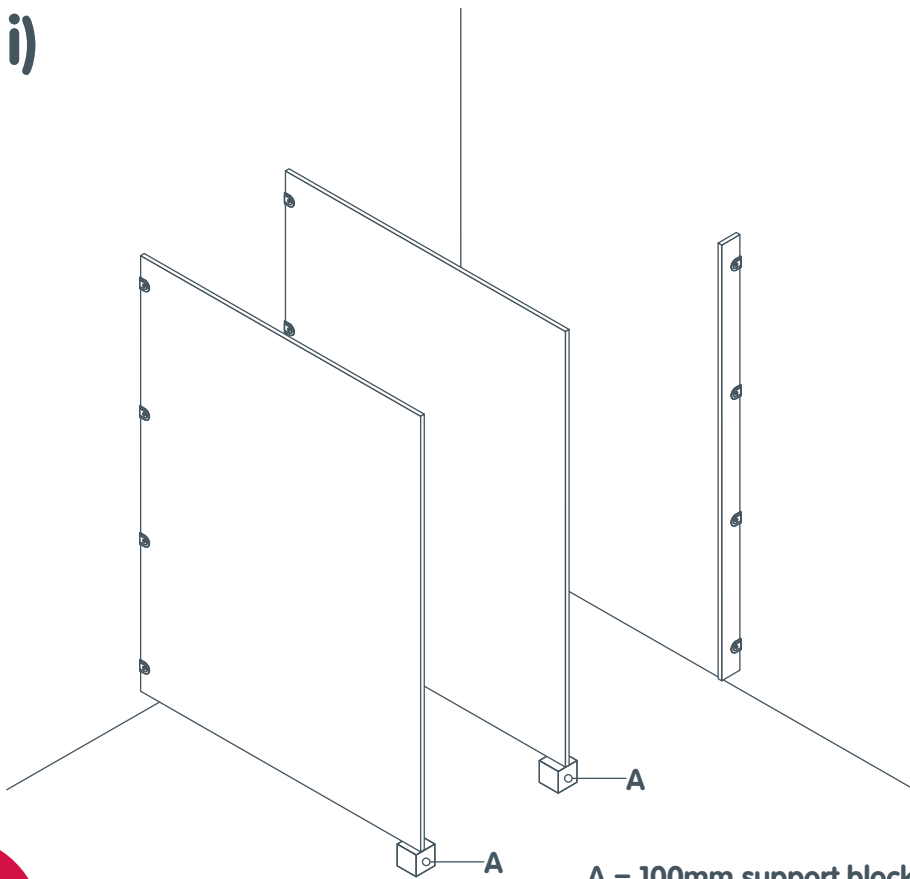

A = 100mm support block
(supplied by others)

2

ii)

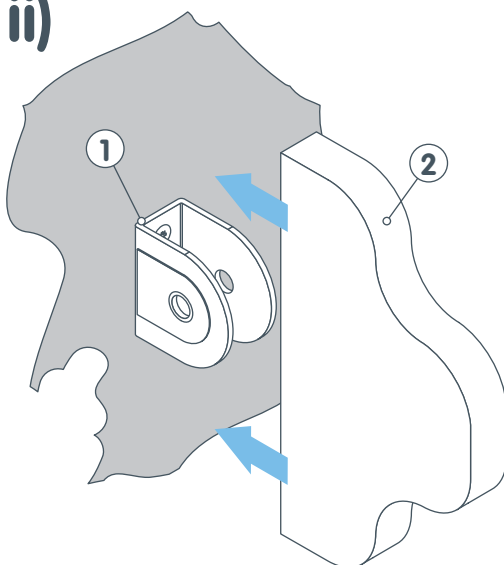

iii)

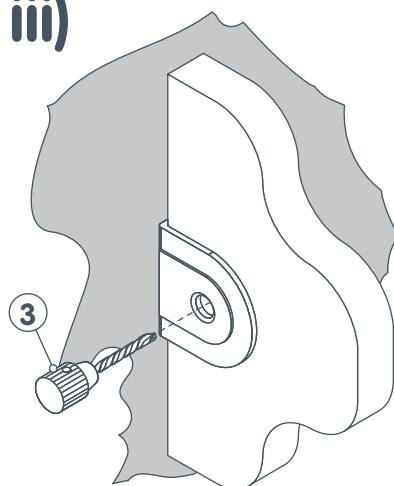

iv)

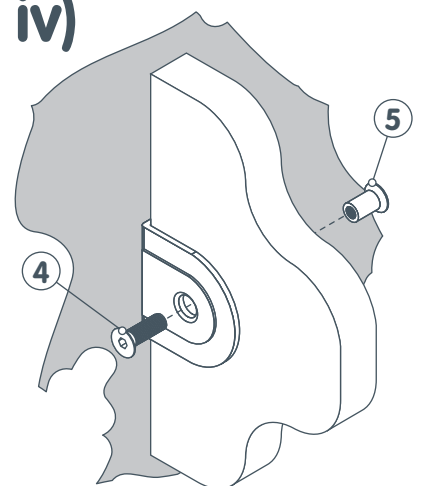

1. Channel bracket
2. Division/pilaster
3. Drill 8mm dia. through hole
4. M6 x 20mm csk socket stainless steel screw
5. Multirol barrel

Pedestal Preparation

i)

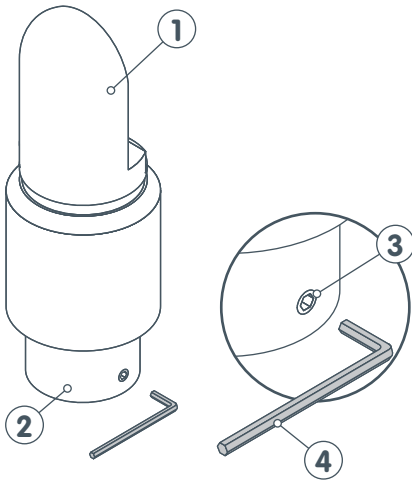

ii)

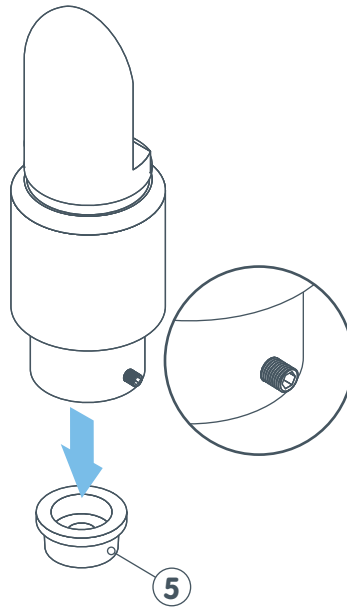

1. Pedestal body
2. Nylon leg adjuster
3. Grub screw
4. 8mm allen key (not supplied)
5. Nylon leg anchor

3

Pedestal Fixing Details

i)

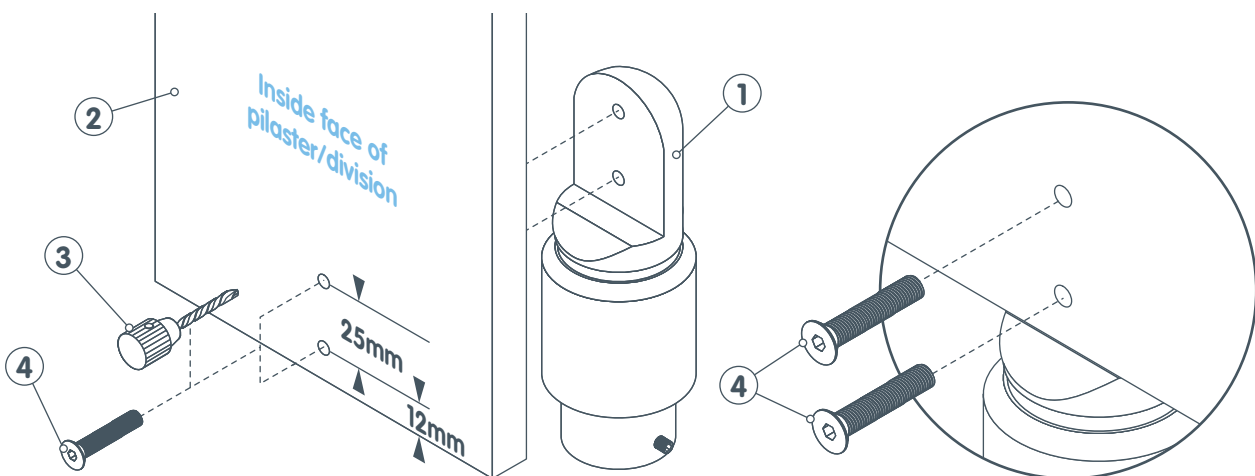

1. Pedestal body
2. Division/pilaster
3. Drill 6mm dia. through hole and countersink
4. M6 x 25mm 'T-nut' screws

3

ii)

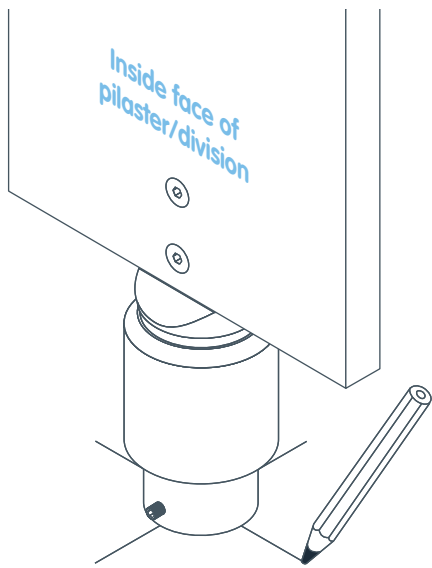

iii)

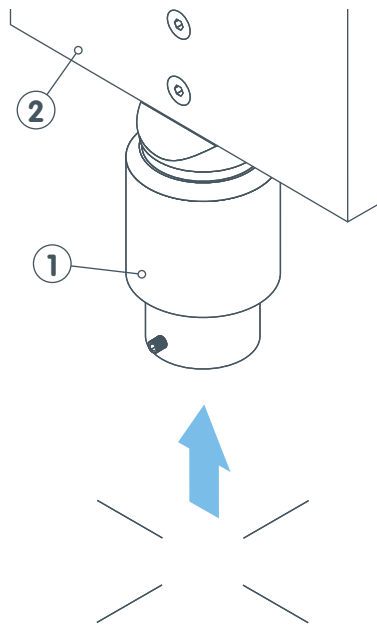

3

iv)

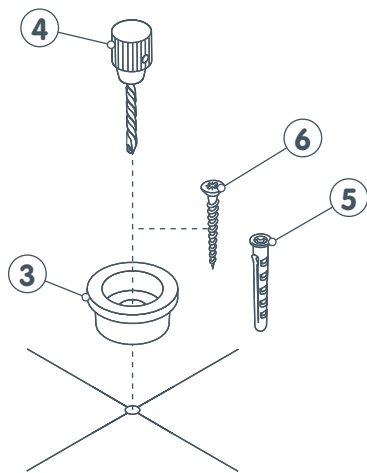

v)

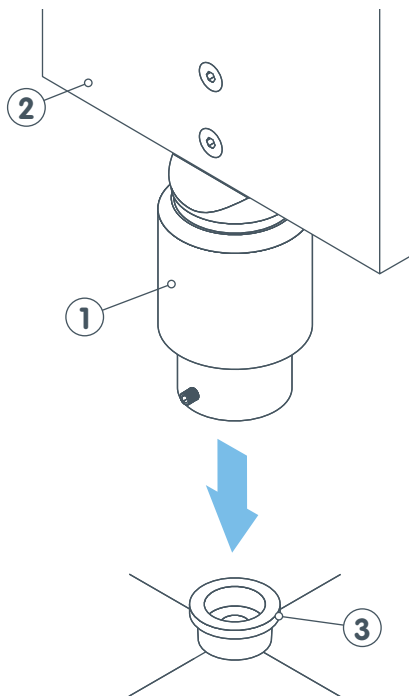

- 1. Pedestal body
- 2. Division/pilaster
- 3. Nylon leg adjuster
- 4. Drill pilot hole to suit floor
- 5. Rawl plug
- 6. No 8 x 1 1/2" pozi screw

vi)

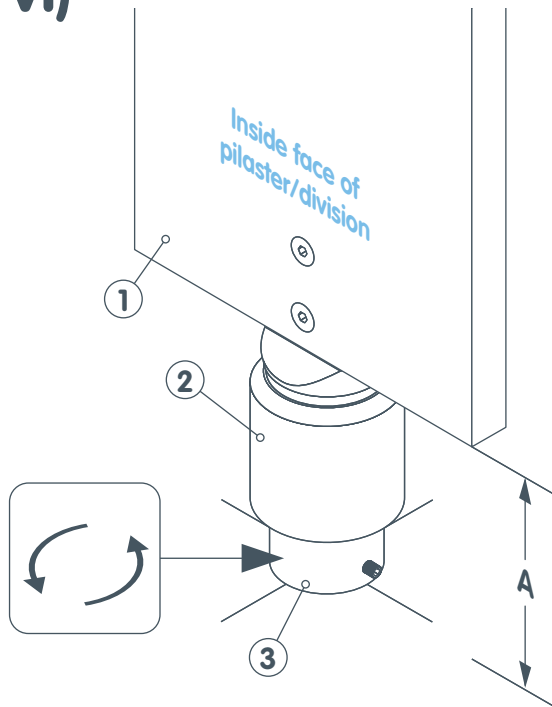

A = 100mm approx
(turn pedestal leg adjuster
to ensure cubicles are level)

vii)

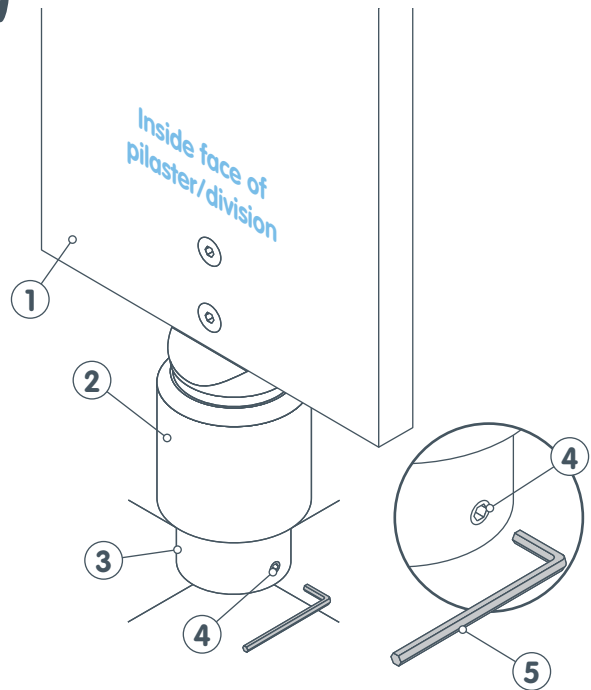

- 1. Pedestal body
- 2. Division/pilaster
- 3. Nylon leg adjuster
- 4. Grub screw
- 5. 8mm Allen key

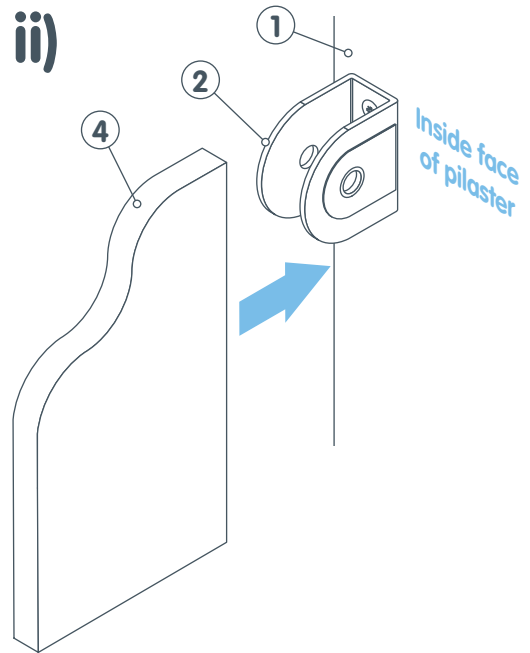
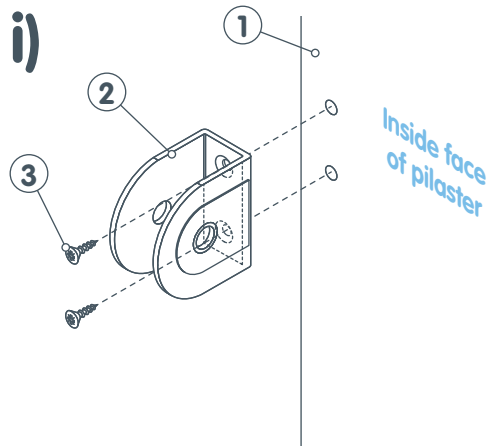

4

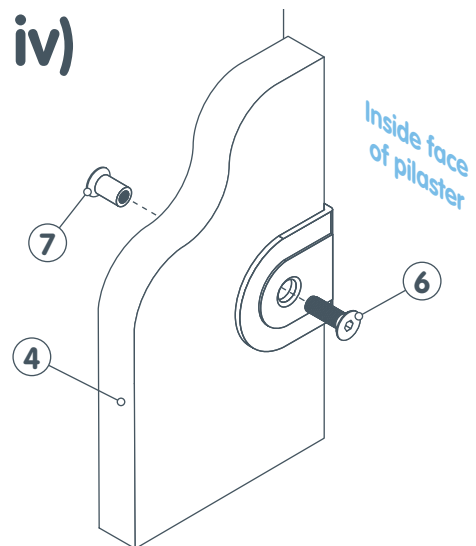
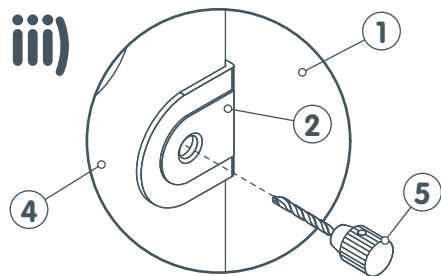

1. Pre-drilled pilaster (intermediate/return end)
2. Channel bracket
3. No. 8 x 18mm csk screws
4. Division
5. Drill 8mm dia. through hole
6. M6 x 20mm csk socket stainless steel screw
7. Multirol barrel

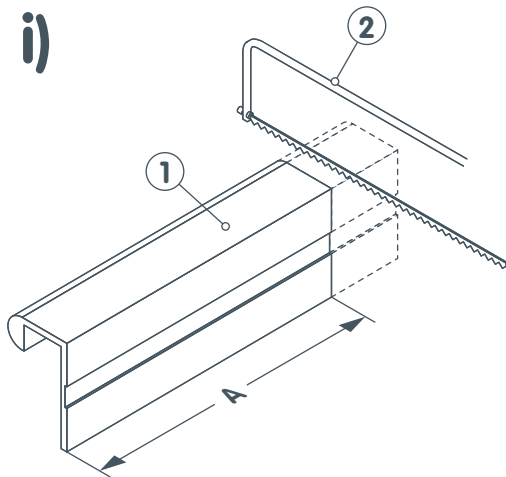

A = Cut length to suit

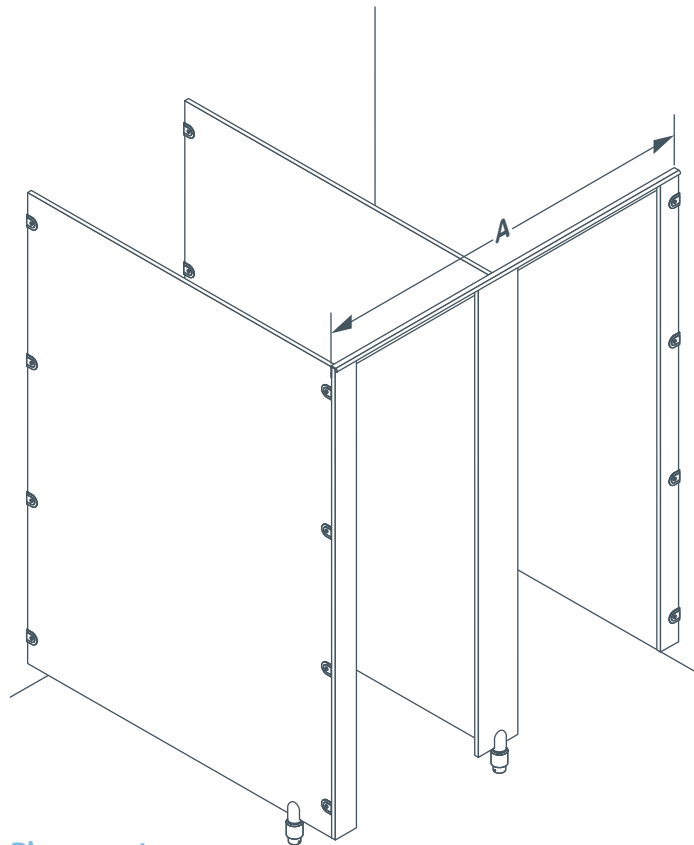

Please note:
If possible always ensure
that cut end is positioned
against wall

5

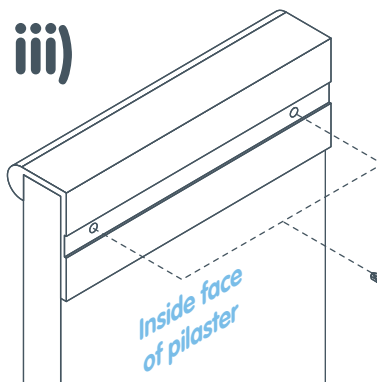
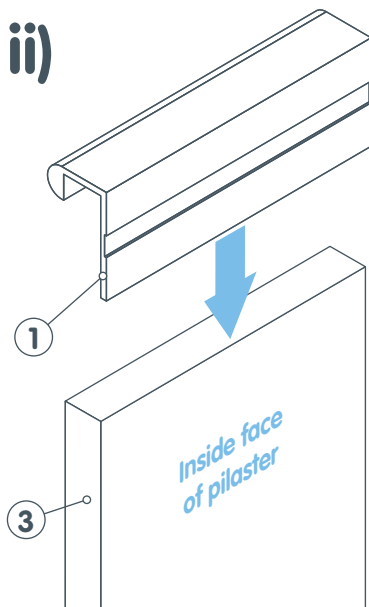

Please note:
Drill two holes per pilaster

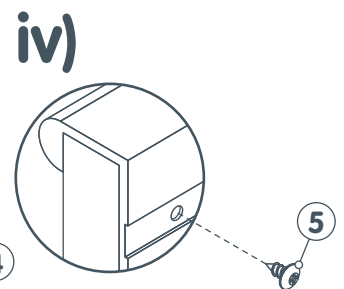

1. Headrail
2. Hacksaw or metal bladed chopsaw
3. Pilaster
4. Drill 4mm dia. x 6mm deep pilot hole
5. No.8 x 18mm flange head screw

i)

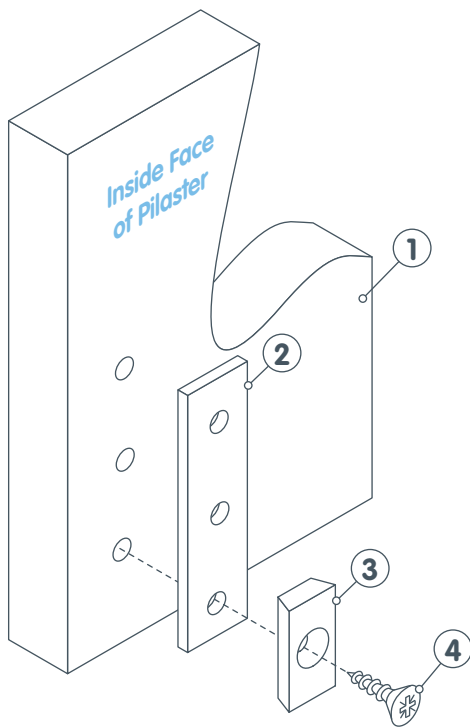

ii)

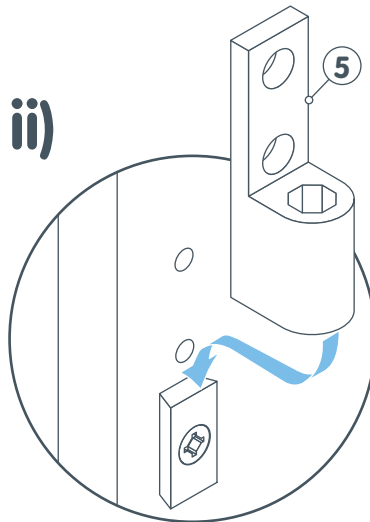

6

iii)

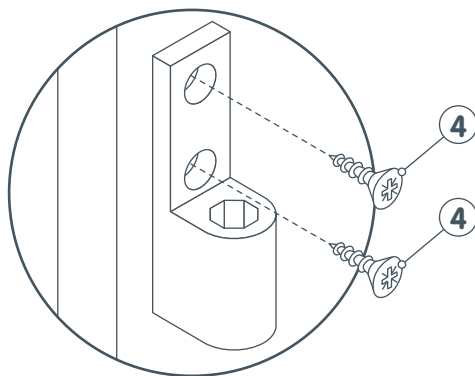

iv)

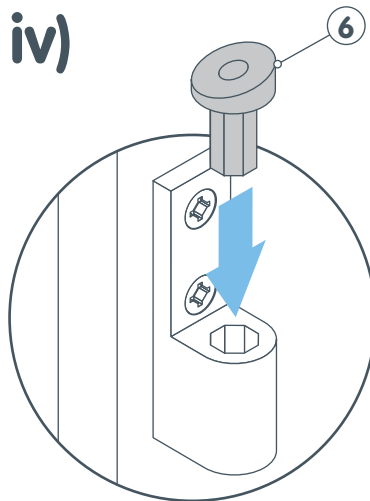

- 1. Pilaster
- 2. Packing plate
- 3. Dovetail plate
- 4. No.12 x 5/8" csk screw
- 5. Hinge body
- 6. Nylon cam

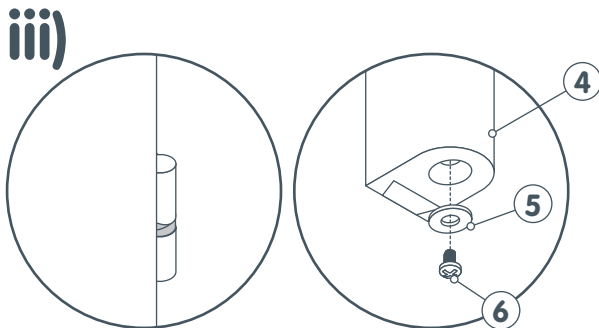
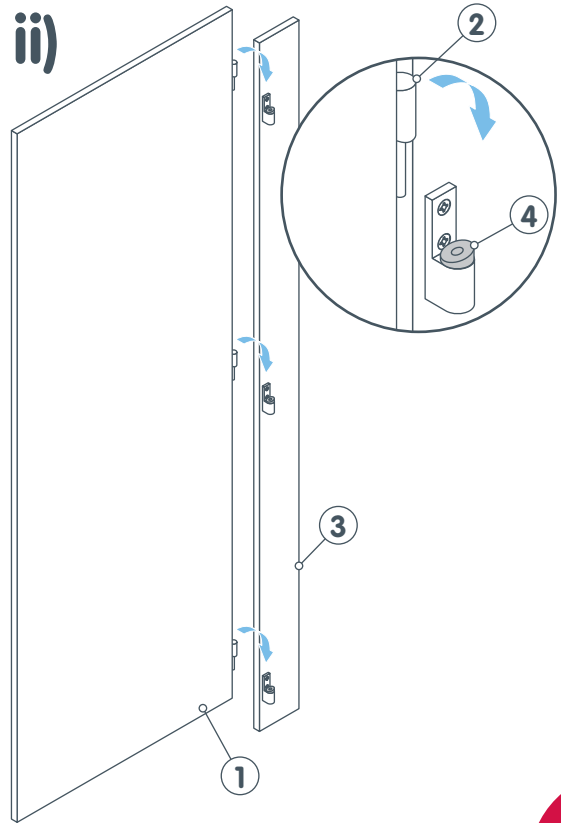
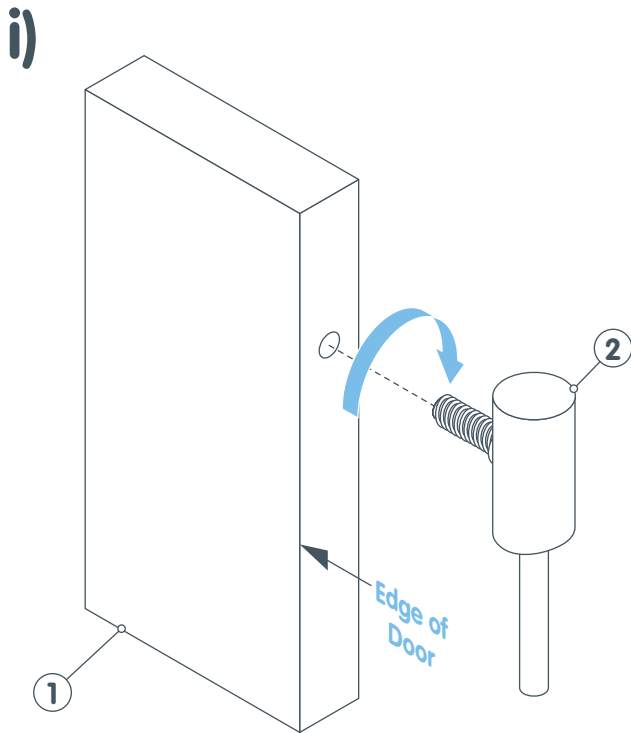

6

- 1. Door
- 2. Hinge top
- 3. Pilaster
- 4. Hinge body
- 5. Washer
- 6. M4 x 6mm retaining screw

i)

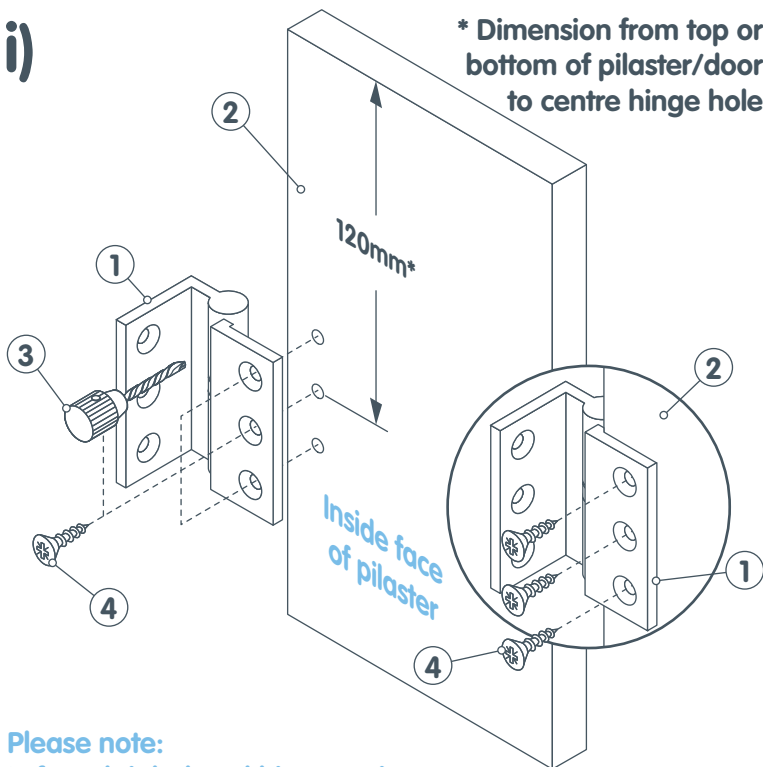

Please note:
Left and right hand hinge variant

7

ii)

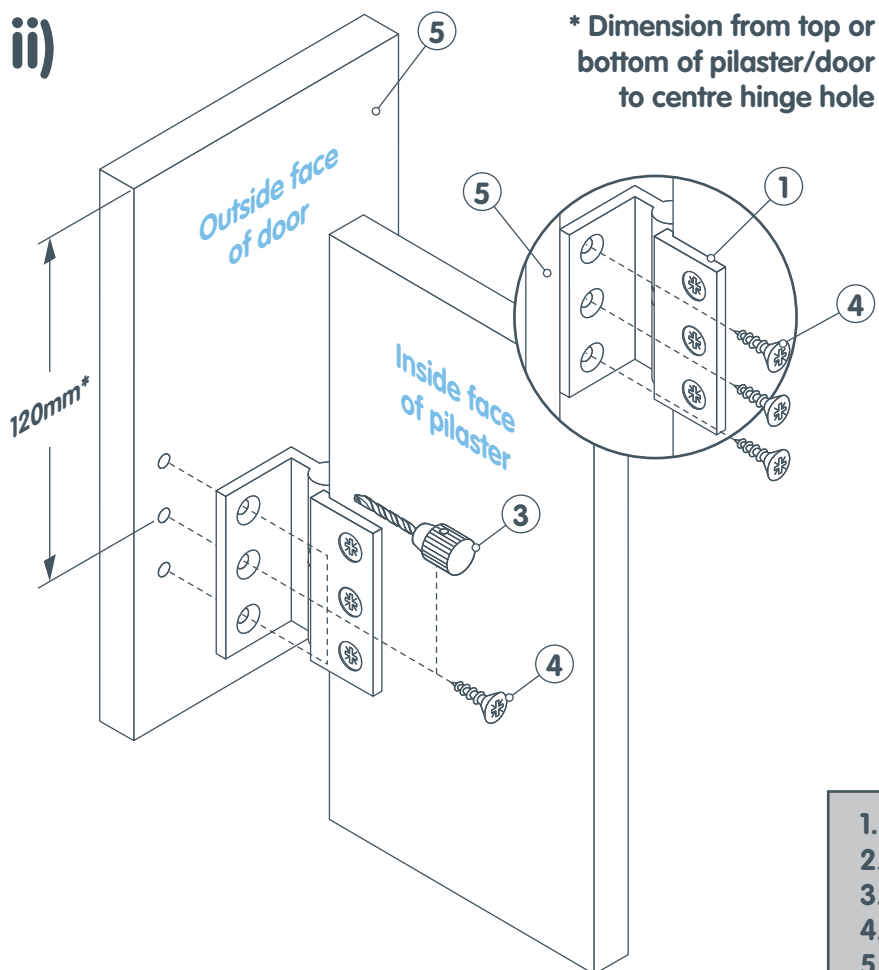

1. Outward opening door hinge
2. Pilaster
3. Drill 3.5mm dia. pilot holes
4. No.12 x 18mm csk screws
5. Outward opening door

Fig. A: Indicator Bolt Assembly Details

i) Fix cam

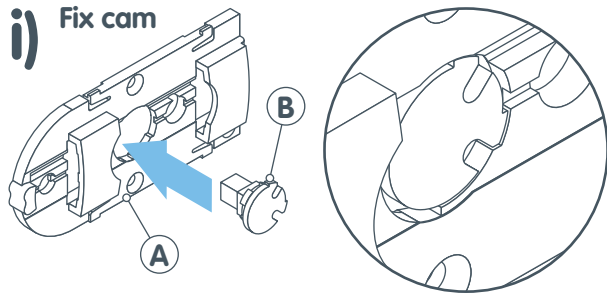

Cam must rotate freely through 180° and be placed in the position shown before progressing further with installation

ii) Fix shoot bolt

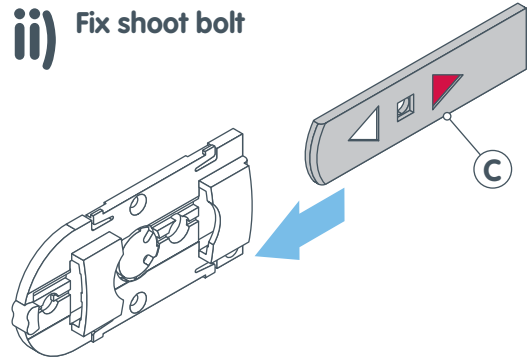

iii) Fix handle

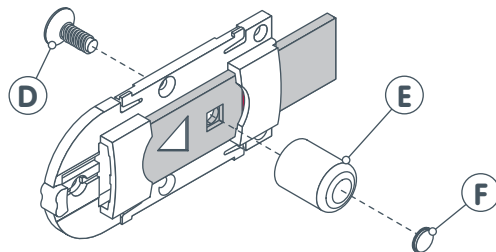

- A. Base
- B. Cam
- C. Shoot bolt
- D. M6 x 12mm csk pozi (ny-lock) screw
- E. Handle
- F. Self adhesive buffer

i) BEFORE FIXING FASCIA:

- Indicator bolt must be pressed against white indicator
- Indicator bolt must be in closed position

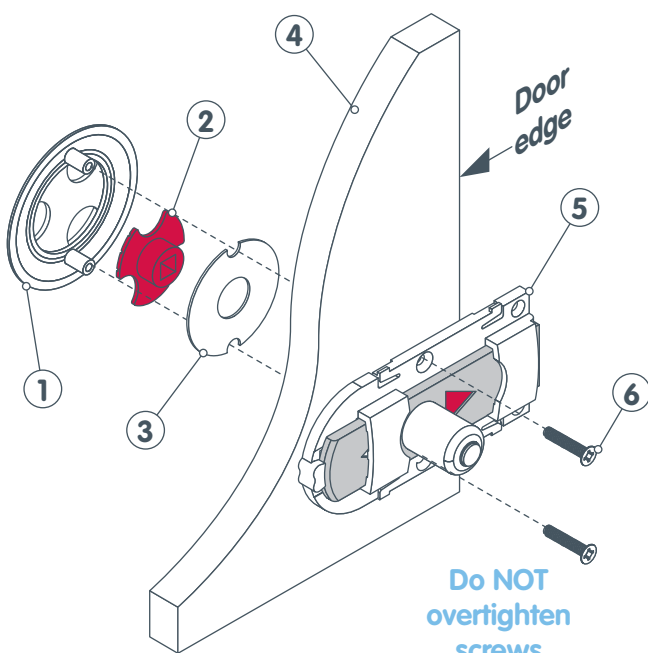

Outside View

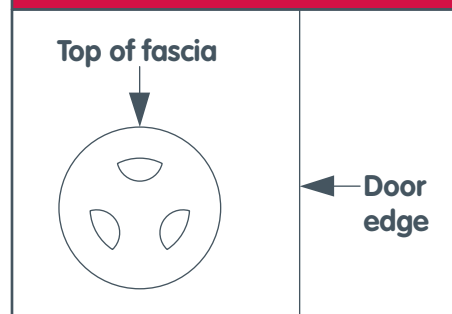

- 1. Fascia
- 2. Red indicator
- 3. White indicator
- 4. Door
- 5. Assembled indicator bolt
- 6. M4 x 20mm csk pozi screws

Indicator Bolt Fixing Details (Continued)

8

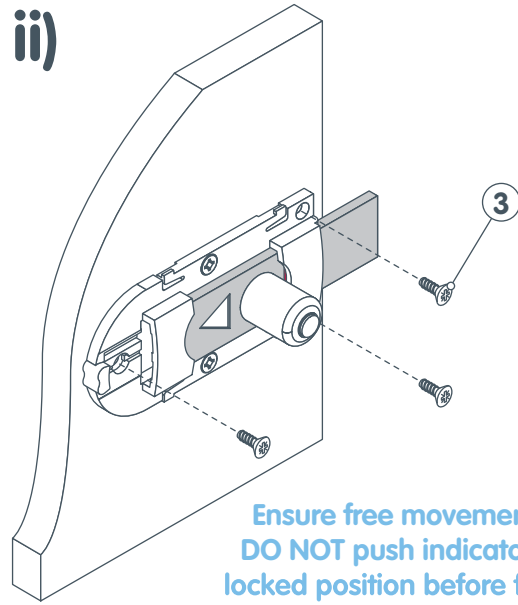
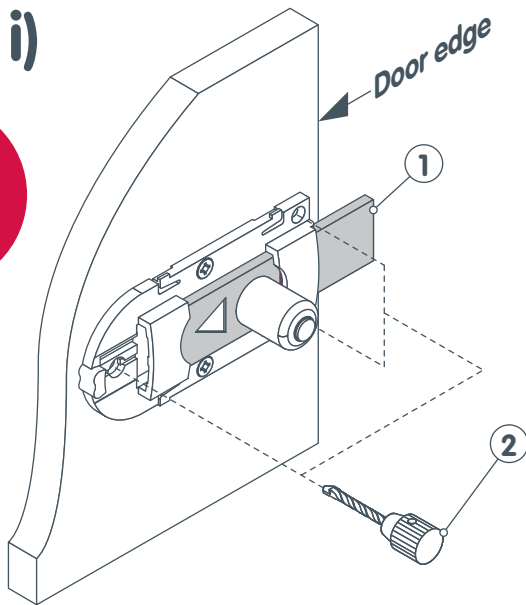

1. Assembled indicator bolt
2. Drill 2mm dia. x 3mm deep pilot hole
3. Plasfix 45' csk 4 x 12mm machine screws

Inward Opening Door Keep Fixing Details

9

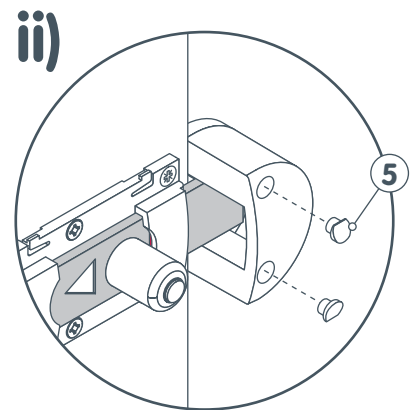
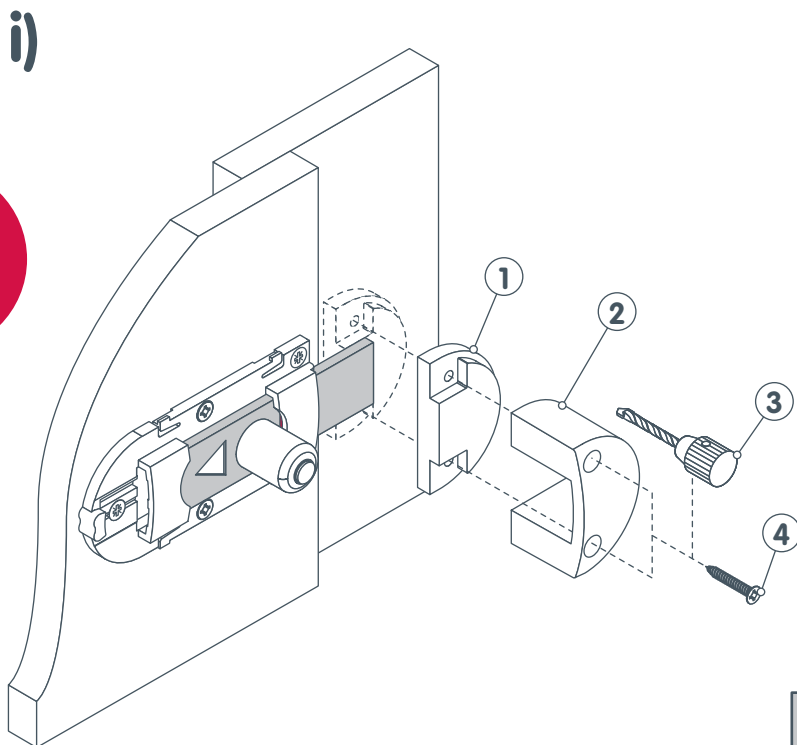

1. Keep spacer
2. Inward opening door keep
3. Drill 2mm dia. x 3mm deep pilot hole
4. No.6 x 1" pozi csk screws
5. Keep plugs

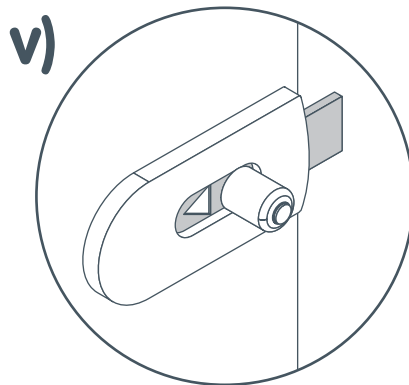
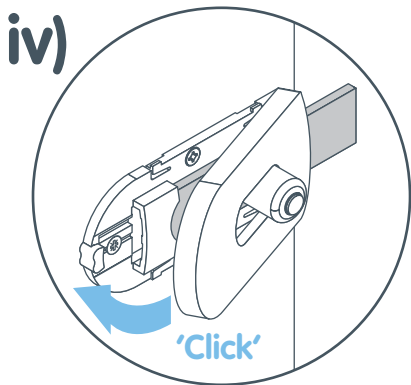
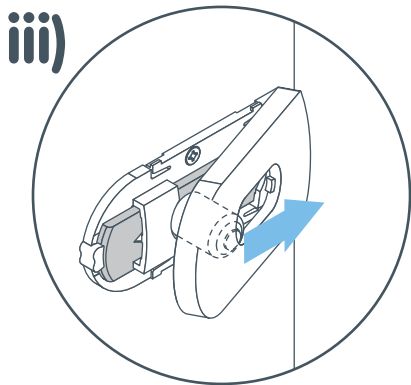
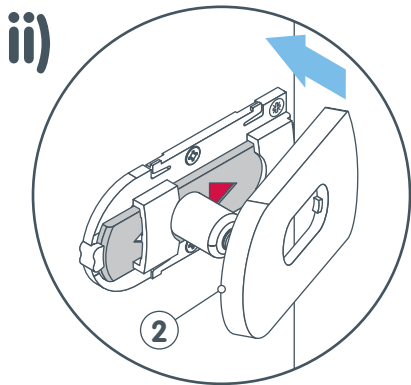
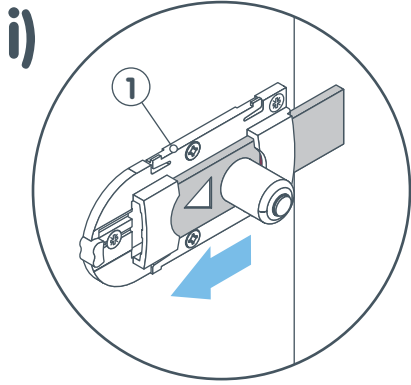

Emergency Release Feature

i) Slide indicator bolt free from keep: insert pen/pencil into recess provided in the outside fascia and rotate red indicator

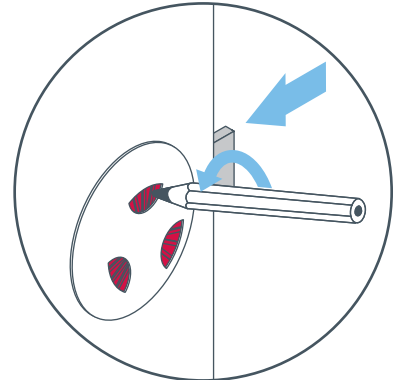

Outside View

ii) • Aluminium keeps will come away from the pilaster when forced
• ABS Keeps are sacrificial and are designed to break in similar circumstances

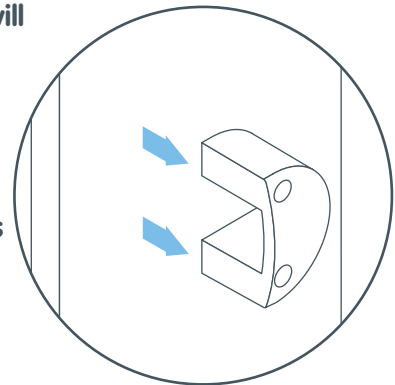

Inside View

Ensure cover is fully pushed on and sits flat

- 1. Assembled indicator bolt
- 2. Cover

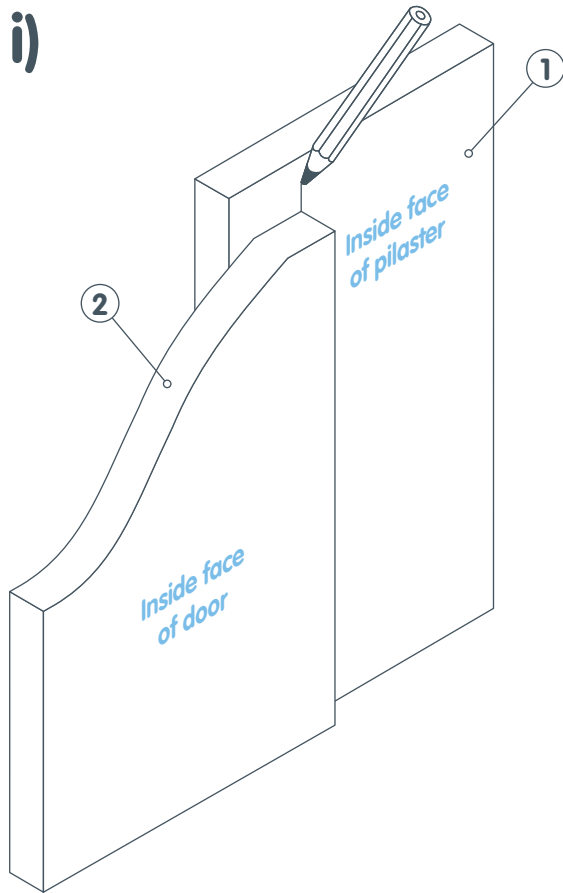

Please note:
To be fixed at top and bottom of pilaster (inward opening doors) or door (outward opening doors)

11

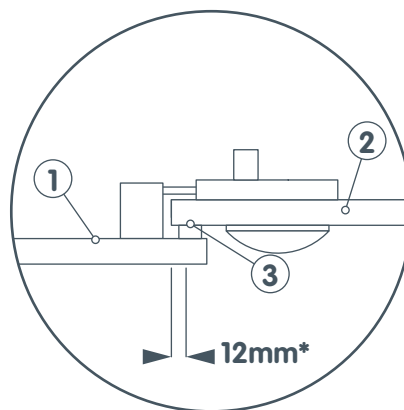
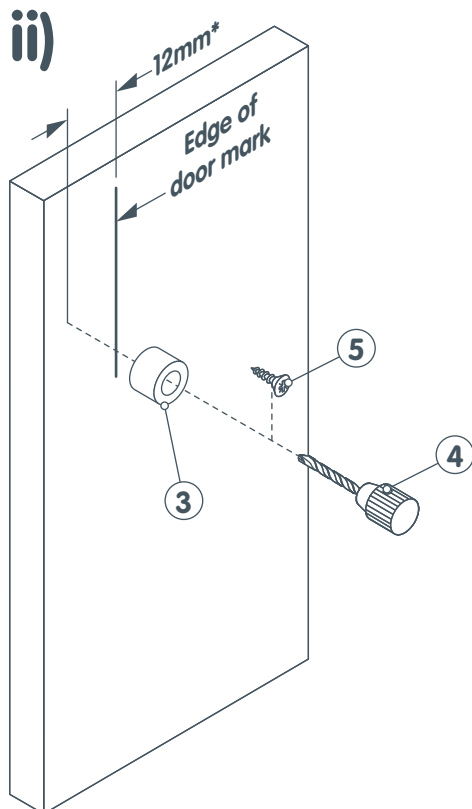

* From edge of door to buffer centre hole

1. Pilaster (closing side)
2. Door
3. Rubber door buffer
4. Drill 2mm dia x 3mm deep pilot hole
5. No.8 x 18mm csk pozi screws

Fig. A: 'Z' Keep Fixing Centres

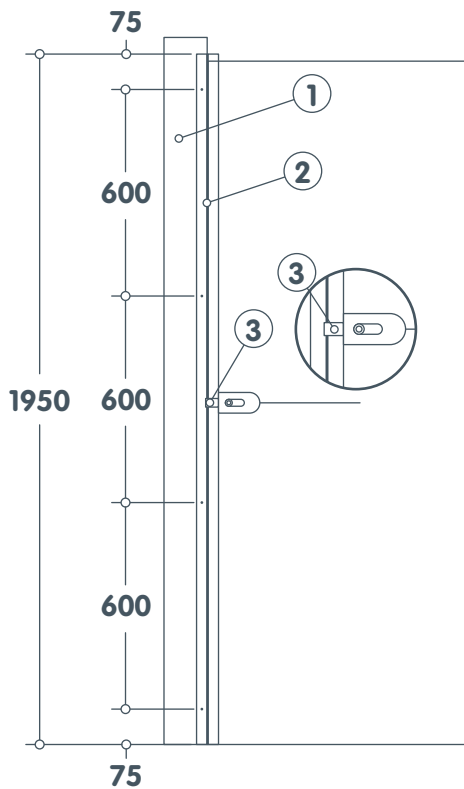
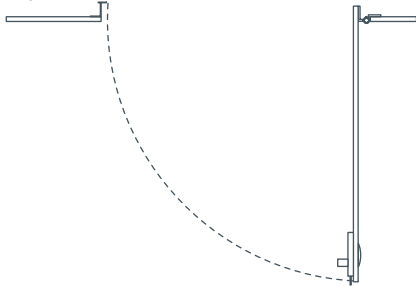

Fig. B: Outward Opening Door Positions

Closed



Open



1. Pilaster (closing side)
2. 'Z' keep
3. Indicator shoot bolt
4. Door buffer base
5. Rubber door buffers
6. No.8 x 1/2" self tapping pan head screws
7. Headrail
8. Pilaster
9. 2mm dia. x 3mm deep pilot holes

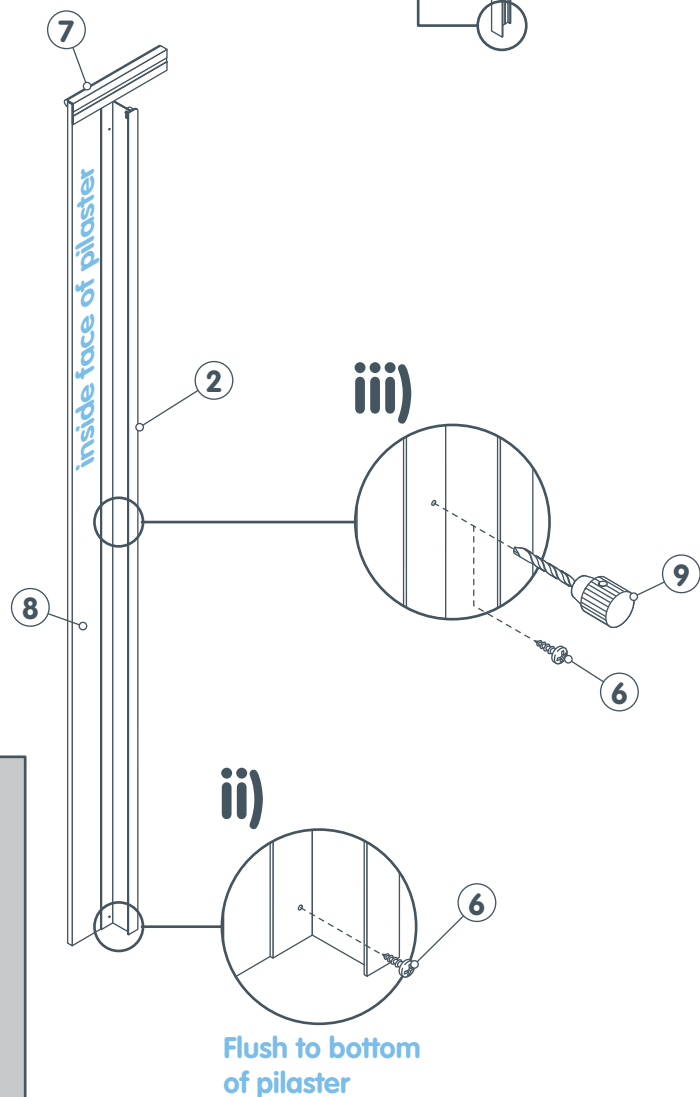
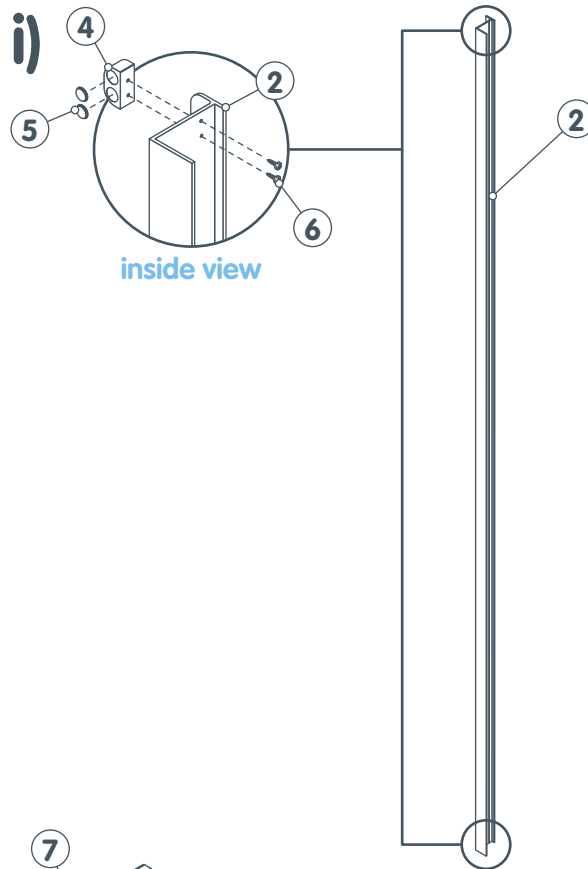

www.amwell-systems.com

Amwell Systems Ltd
Buntingford Business Park
Baldock Road
Buntingford
Herts
SG9 9ER
England

T +44 (0)1763 276200
F +44 (0)1763 276222
contact@amwell-systems.com