

SMART FIXING SYSTEMS

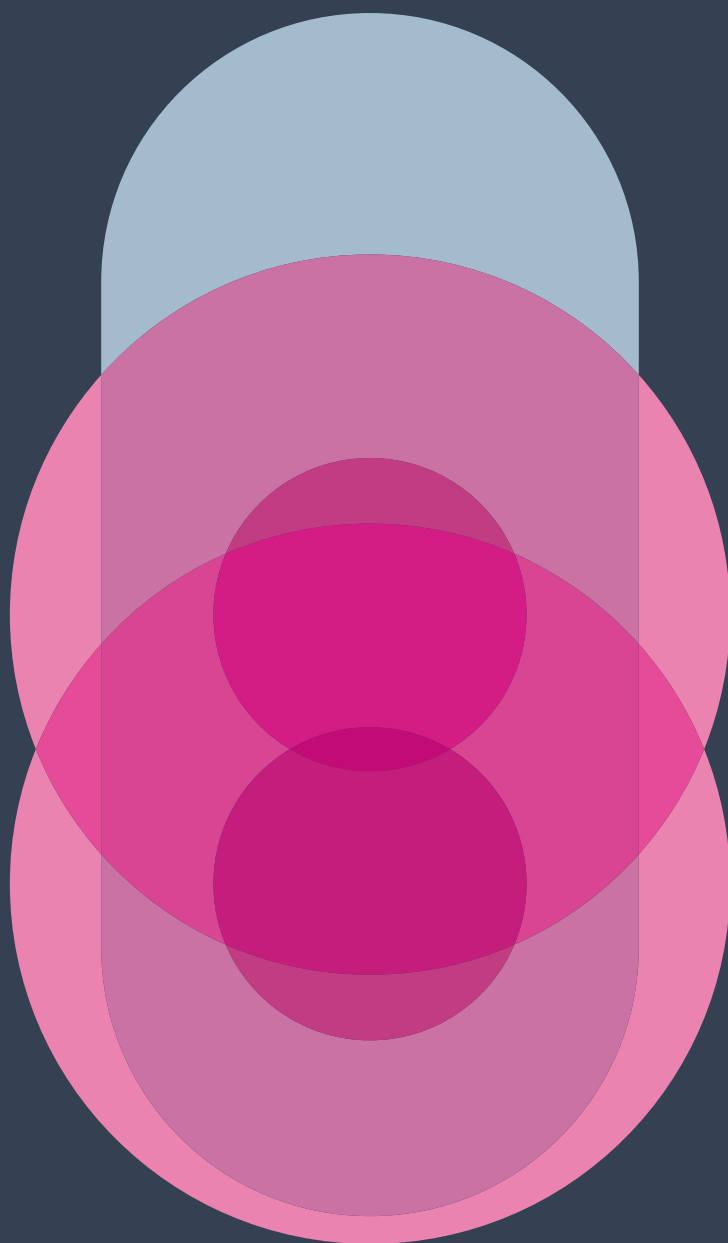

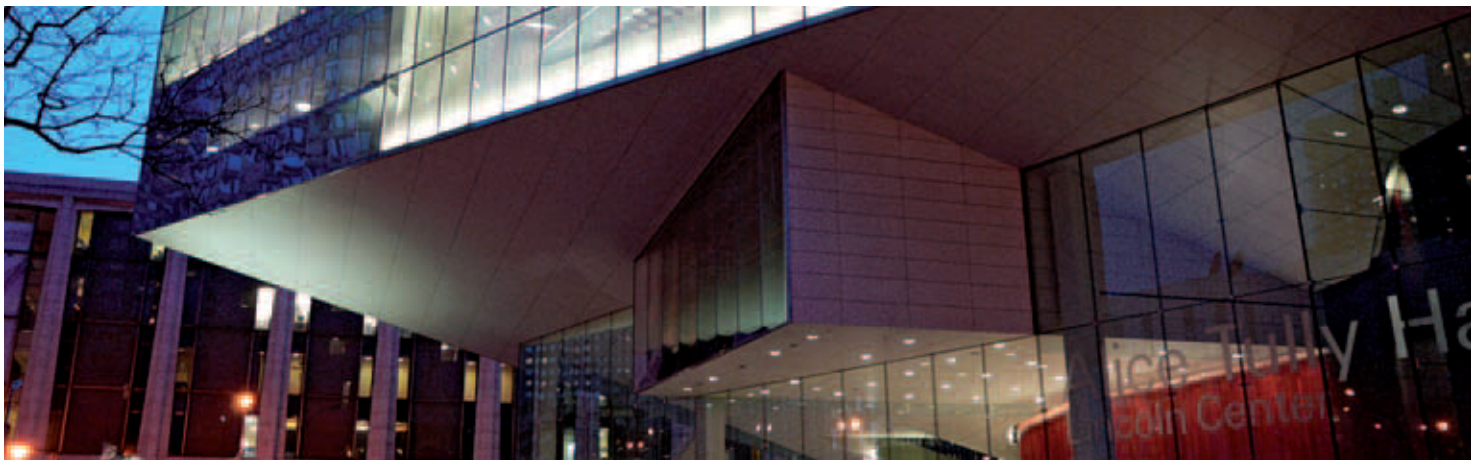



REAR-VENTILATED FACADE

The hung, rear-ventilated facade (RVF) covers the load bearing wall of a building. With a RVF, the facade elements are mounted with the help of a fixing system at a distance from the building's outside wall.

Besides the varied architectural possibilities, this method of construction has considerable ecological and economical benefits:

- The RVF protects against weather conditions and contributes to the longevity of the building. The outside wall of the building and the thermal insulation remain dry always.
- The RVF minimises thermal stress and is the optimum protection against heat and cold.
- The RVF is an energy-saving façade. The variable lengths of wall brackets make it possible to install with any desired thickness of insulation. Energy savings leads to minimisation of carbon dioxide discharge.
- Back ventilating the façade controls the humidity of the building and ensures an optimum climate inside.
- The multilayered structure of RVF protects against noise.
- The RVF system guarantees sustainable construction through recycling the components that are used.

SYSTEMF1.10

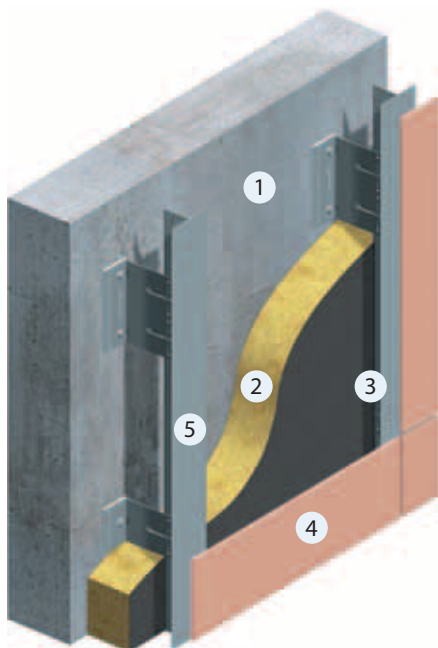

SYSTEMF2.10

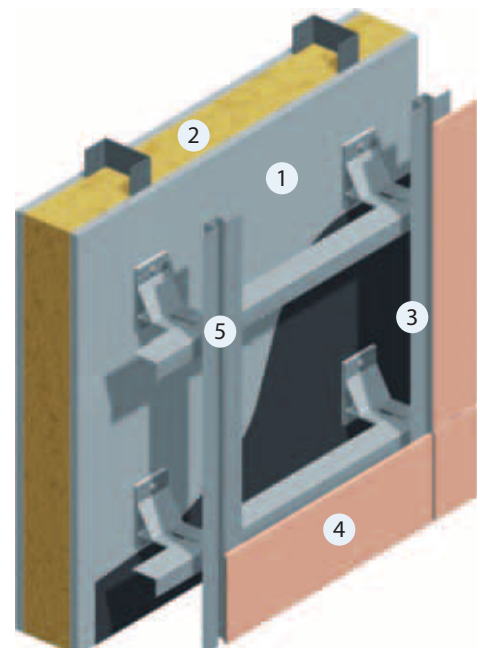

CONSTRUCTION OF THE RVF

- 1 Load bearing wall
- 2 Insulation
- 3 Ventilation space
- 4 Facade panel
- 5 Allface substructure

ALLFACE SMART FIXING SYSTEMS

The critical element and basis of a fixing system is the wall bracket. It decides the layout of the facade's substructure.

WALL BRACKET F1

Wall bracket F1 is used for vertical fixing on solid walls.

Technical Features and Benefits

- Wind pressure is passed right to the building element – no tensile load on the dowel.
- Each F1 can be used for a fixed point or a sliding point.
- The F1+ is mainly used as an anchor point. It has high load bearing capacity due to its design with a height of 175 mm combined with 2 wall fixing points .
- Dowel spacing of 125 mm for the F1+ makes it possible to fasten to a problematic subgrade.
- Integrated clamp-slide provides 38 mm of adjusting for the L- or T-profiles.
- Made of aluminium EN-AW 6060 T66

Wall Bracket	Throat depth A*	Distance to Wall B
F1.35	35 mm	37–75 mm
F1.50	50 mm	52–90 mm
F1.80	80 mm	82–120 mm
F1.100	100 mm	102–140 mm
F1.115	115 mm	117–155 mm
F1.135	135 mm	137–175 mm
F1.150	150 mm	152–190 mm
F1.170	170 mm	172–210 mm
F1.185	185 mm	187–225 mm
F1.220	220 mm	222–260 mm
F1.255	255 mm	257–295 mm

* other throat depths on request

WALL BRACKET F2

The wall bracket F2 is mainly used for horizontal fixings on beam- and column constructions.

Technical Features and Benefits

- High bearing capacity due to the design.
- For mounting on beam- and column structures.
- Each F2 can be used for a fixed point or a sliding point. The F2+ primary use is as a fixed point, due to its high load bearing capacity.
- Integrated clamp-slide provides 38 mm of adjusting for the horizontal profiles.
- Made of aluminium EN-AW 6060 T66.

Wall Bracket	Throat depth A	Distance to Wall B
F2.50	50 mm	52–90 mm
F2.80	80 mm	82–120 mm
F2.115	115 mm	117–155 mm
F2.150	150 mm	152–190 mm
F2.185	185 mm	187–225 mm
F2.220	220 mm	222–260 mm
F2.255	255 mm	257–295 mm
F2.290	290 mm	292–330 mm

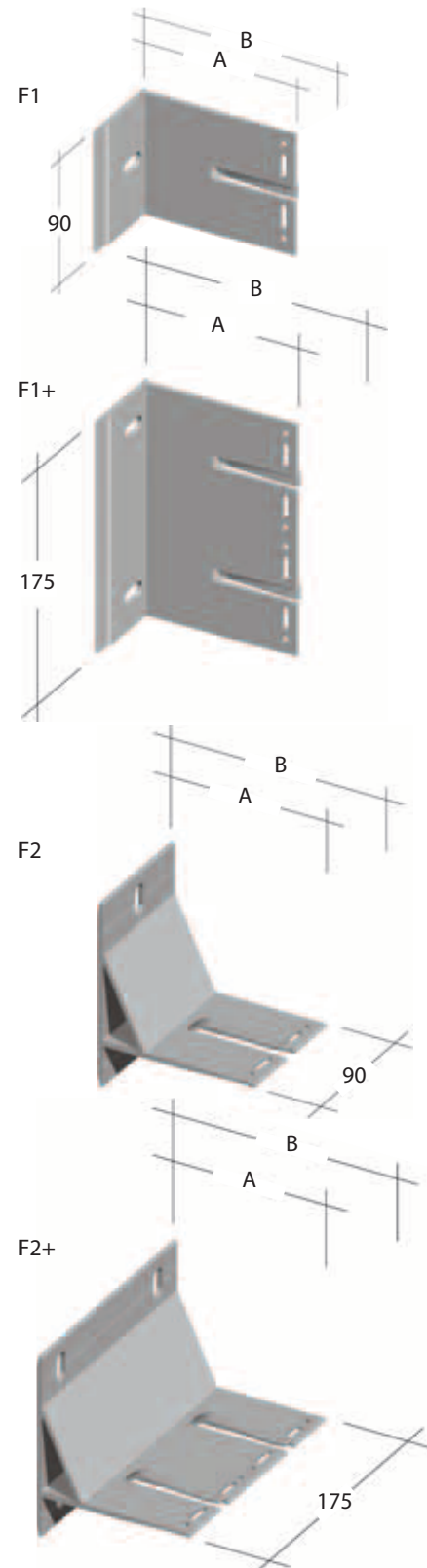

WALL BRACKET F3

The F3 wall bracket is used for vertical fixing systems from ceiling to ceiling.

Technical Features and Benefits

- High load carrying capacity due to overall height and 4 wall fixings per bracket for dowels or screws.
- Large spans can be achieved due to a solid supporting beam recess.
- Floor high supporting beams up to 3500 mm can be used.
- Each F3 bracket is able to perform a fixed and sliding point function.
- Made of aluminium EN-AW 6060 T66.

Wall Bracket	Throat depth A*	Degree of opening C
F3.80	80 mm	60 mm
F3.135	135 mm	60 mm

* other throat depths on request

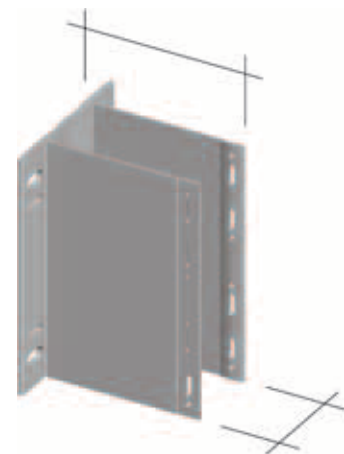
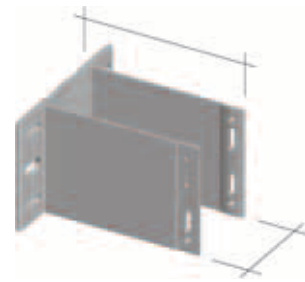

WALL BRACKET F4

The F4 wall bracket is used mainly on solid walls for receiving aluminium supporting beams or wooden supporting laths.

Technical Features and Benefits

- Individual dimensions according to customer's requirements.
- Brackets are project related; defined by wall thickness and height, the fixings and dowel holes are variable according to static requirement calculations.
- Construction allows for an additional supporting lath within the base of the bracket to cope with increased loads.
- Made of aluminium ALMG 3.

Wall Bracket	Throat depth A*	Degree of opening C
F4	min. 35 mm	min. 30 mm

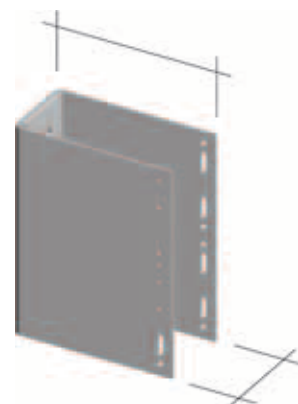
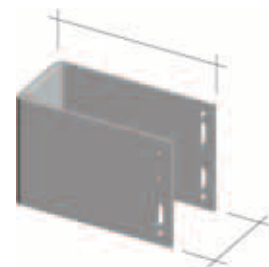

ALLFACE SYSTEM BASICS

Basically, fixing systems are differentiated according to visible or concealed fastening and horizontal or vertical fixing.

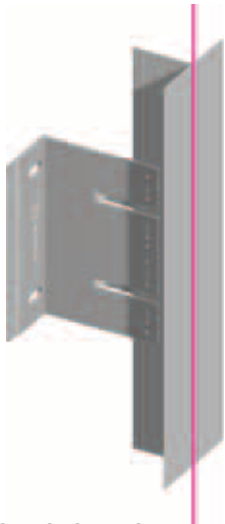

VERTICAL SYSTEMS

Vertical systems are used for mounting on solid walls. The primary profile is mounted vertically on an F1.

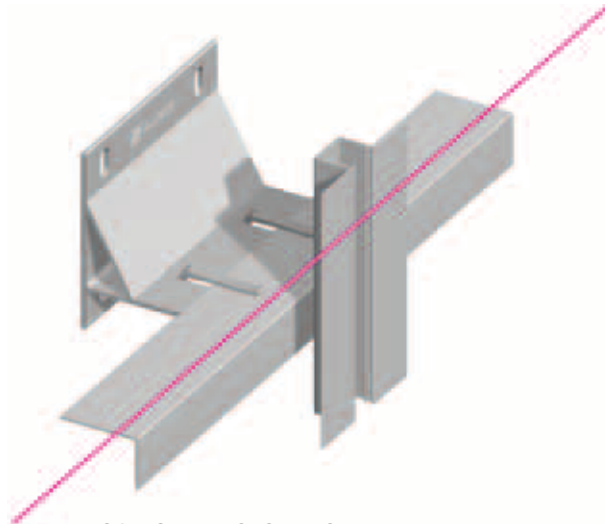

HORIZONTAL SYSTEMS

For structures of beam and column construction, horizontal systems are used exclusively where the primary profile is mounted horizontally on an F2.

SYSTEMF1, F2, F4

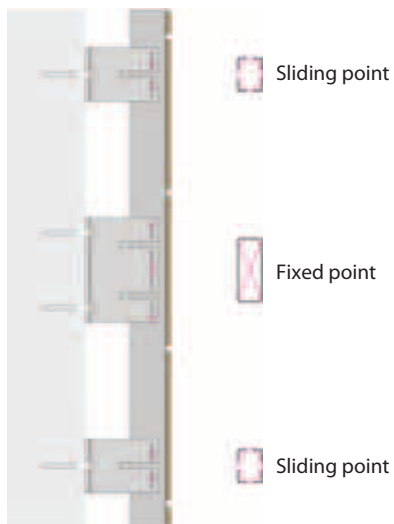

SYSTEMF3

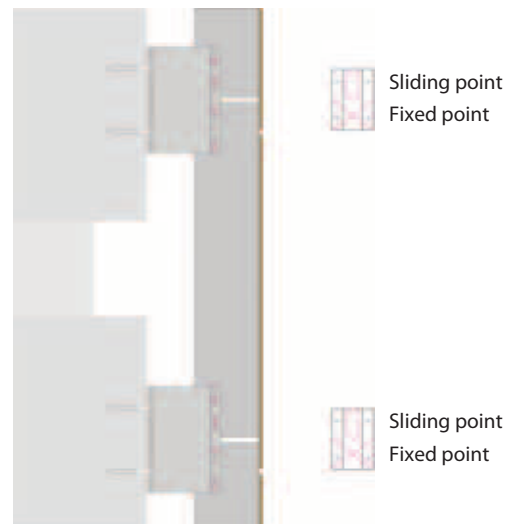

THERMAL LINEAR EXPANSION

When mounting vertical or horizontal systems, temperature-related linear expansion of the profiles must be taken into consideration. For this reason, the elongated holes of the wall brackets allow for thermal expansion of the section. The length of the profiles is determined by the storey- height or panel separation.



FIXED POINT

The fixed point passes the dead weight and wind loads to the load-bearing wall. The connection between the wall bracket and profile is therefore immobile when fixed through the "round holes".

For connections of primary profiles and carrier rails, fixed and sliding points are also used for fastening.

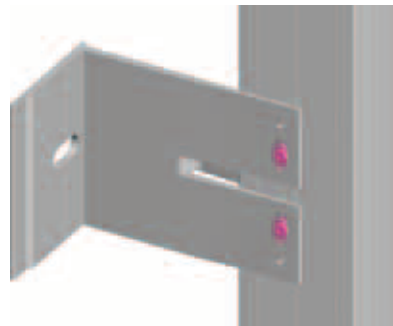

SLIDING POINT

In contrast, the connection between a sliding point and the profile is designed to be a sliding connection in elongated holes. As a result, the profile allows for thermal expansion and contraction with no jammed connections.

For a sliding point, only wind pressure loads are passed to the load bearing wall.



FIXED POINT

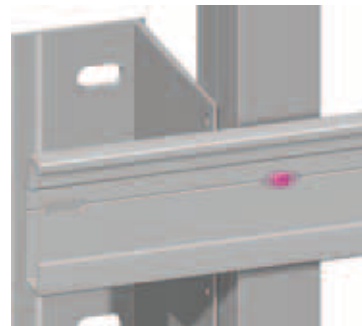

SLIDING POINT



THERMAL SEPARATION

In order to avoid thermal bridges or alternatively to minimise heat losses, thermal separation elements are built in between the wall bracket and the outside wall.

SMART FIXING SYSTEMS

VISIBLE FIXING WITH RIVETS OR SCREWS

Facade fastening with rivets is a very economical method of installation due to the easy mounting. It is mainly used for metal, fibre cement and High Pressure Laminate - HPL facade elements.

SYSTEM F1.10

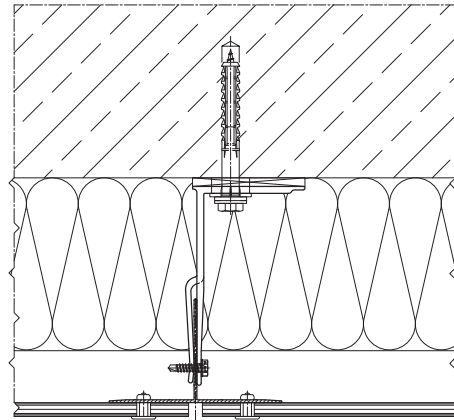
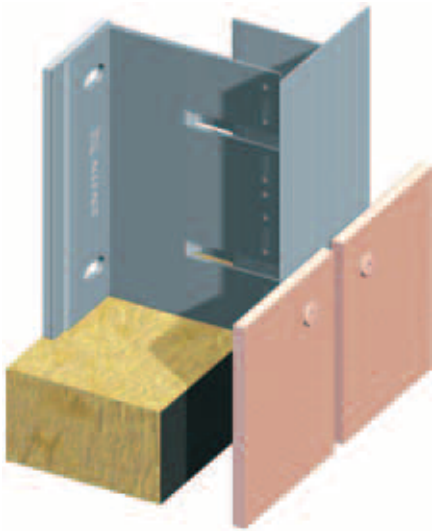

SYSTEM F2.10

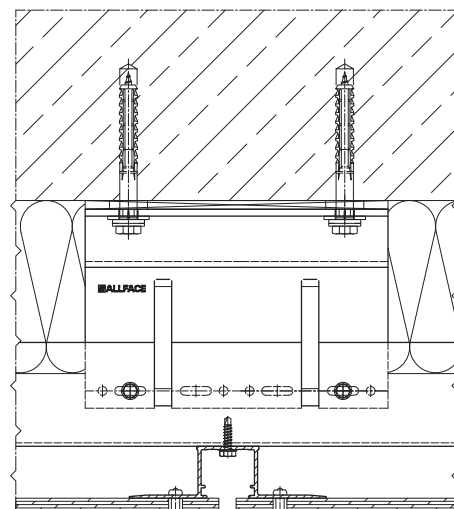
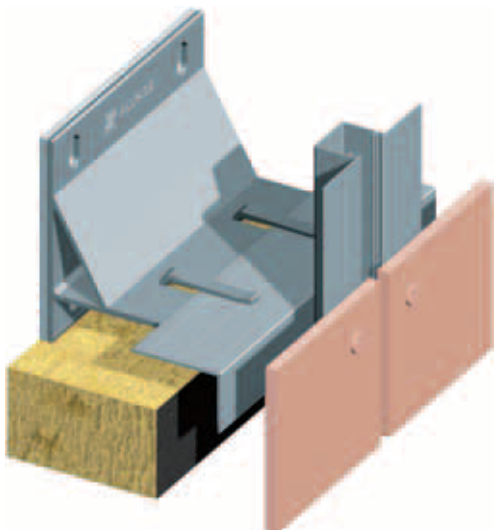

SYSTEM F3.10

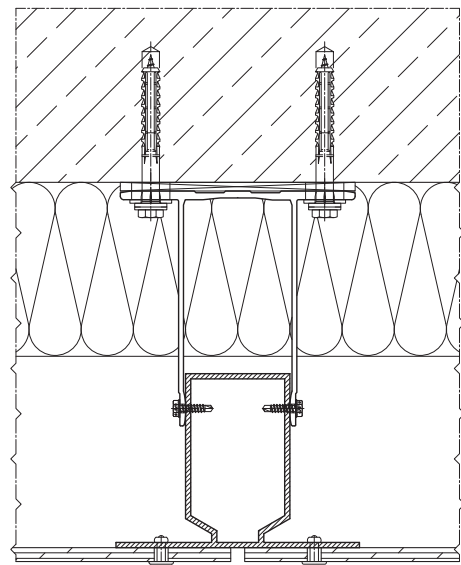
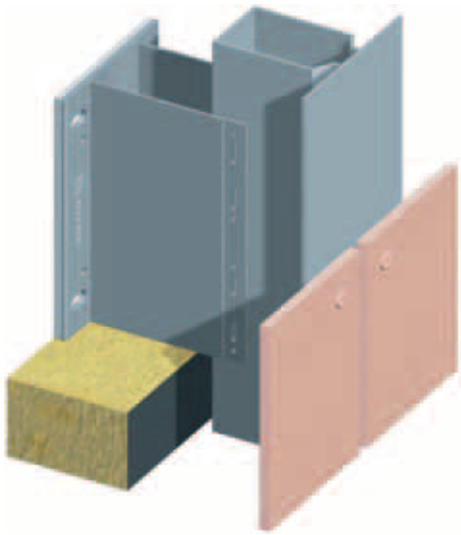

SYSTEM F4.10 H

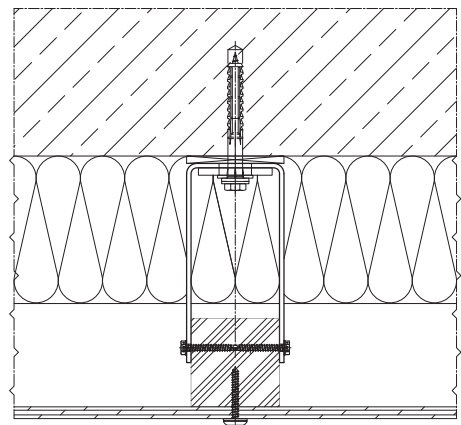
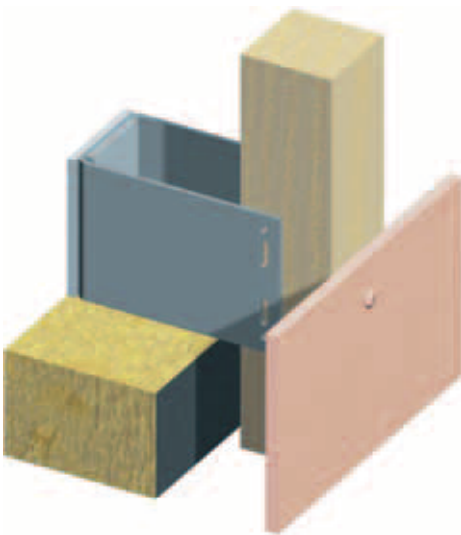

VISIBLE FIXING WITH CLAMPS

Fastening by means of clamps is used in particular for ceramic and terracotta facade elements. The clamps are available in aluminium and stainless steel and can be made to match the colour of the facade elements.

SYSTEM F1.20

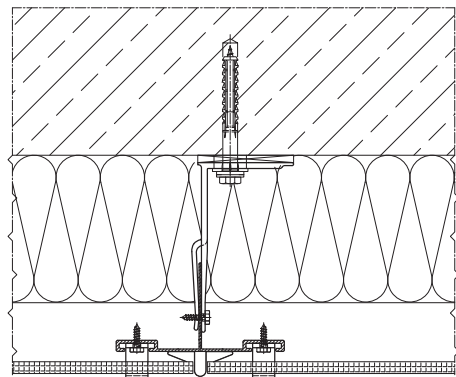
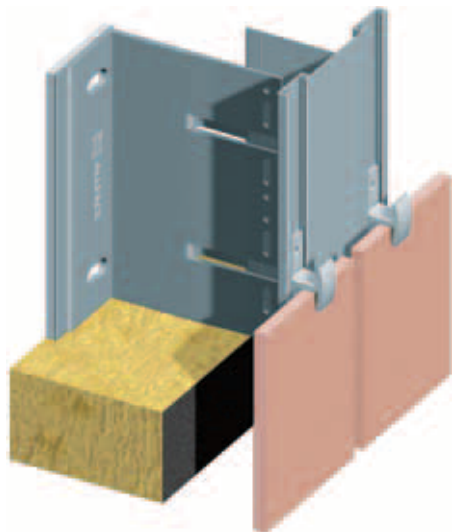

SYSTEM F2.20

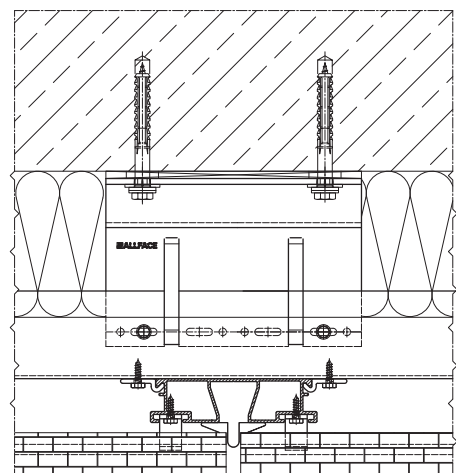
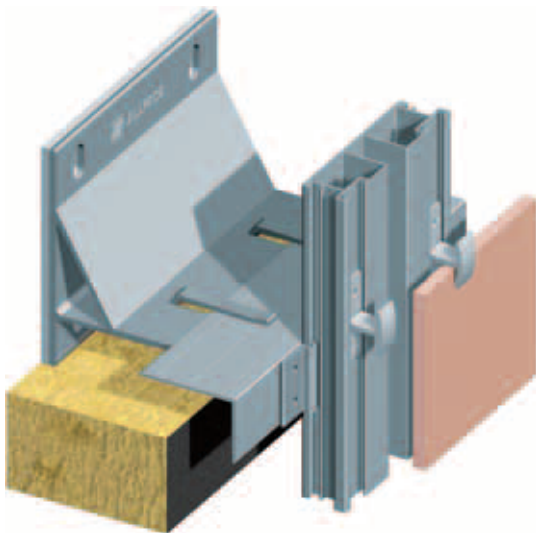

CONCEALED FIXING WITH ADHESIVE SYSTEM

Glueing facade panels is an economical mounting method. The panels are assembled on the properly pre-treated profiles with permanent elastic glue and with double-sided adhesive mounting tapes.

SYSTEM F1.30

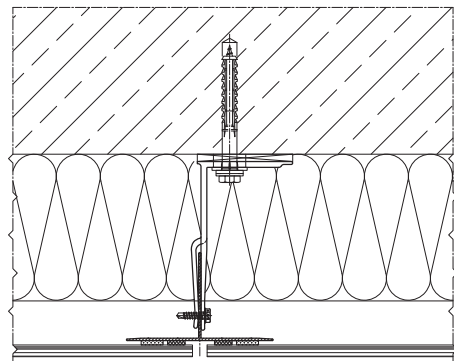
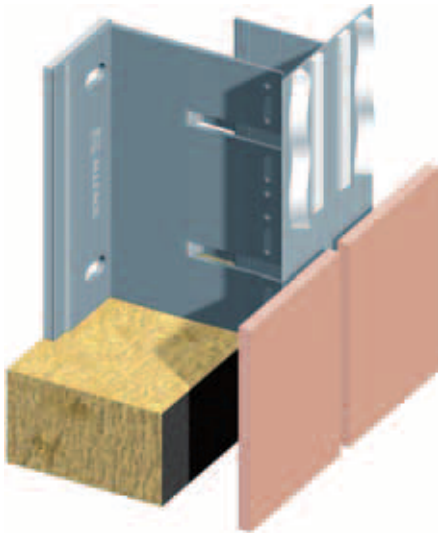

SYSTEM F2.30

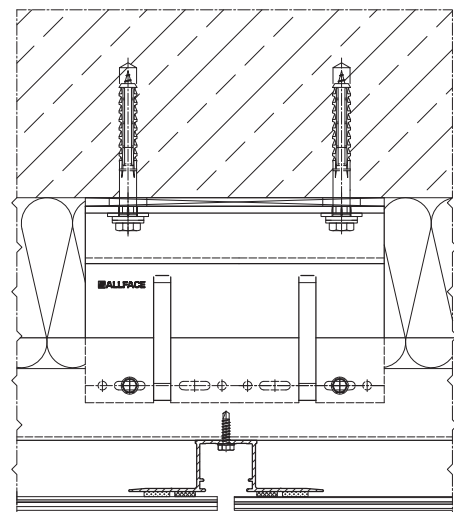
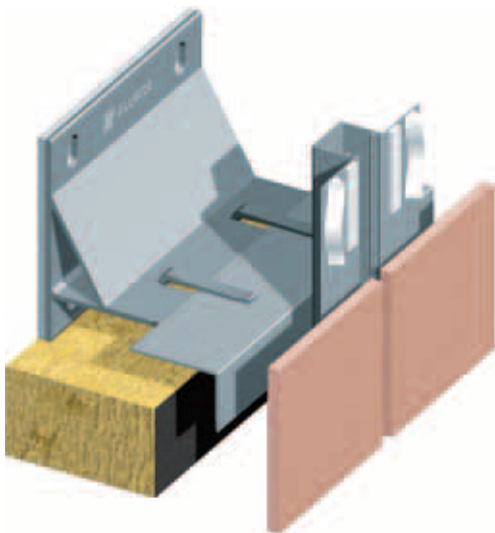

CONCEALED FIXING WITH ADHESIVE SYSTEM

Glueing facade panels is an economical mounting method. The panels are assembled on the properly pre-treated profiles with permanent elastic glue and with double-sided adhesive mounting tapes.

SYSTEM F3.30

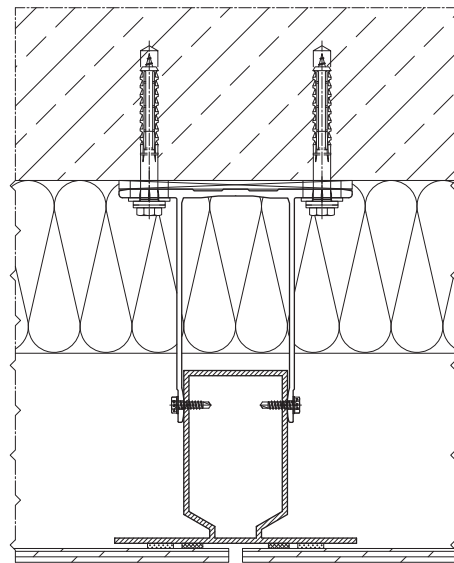
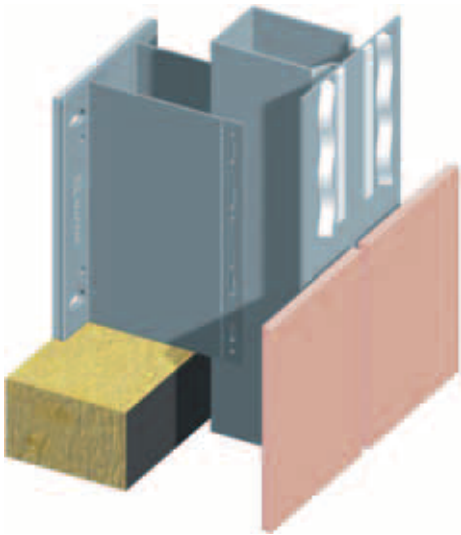

CONCEALED FIXING WITH UNDER-CUT ANCHORS

Facade panels can be fastened mechanically and concealed with the help of undercut anchors. Hanger elements are put into the undercut drill hole on the back of the panel with special dowels. Each facade panel is fastened with at least four individual hanger elements.

SYSTEM F1.40

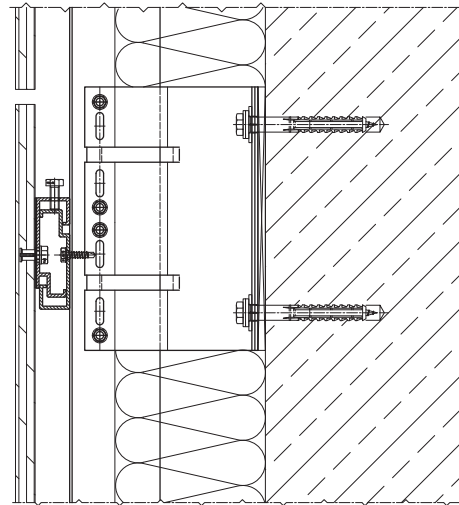
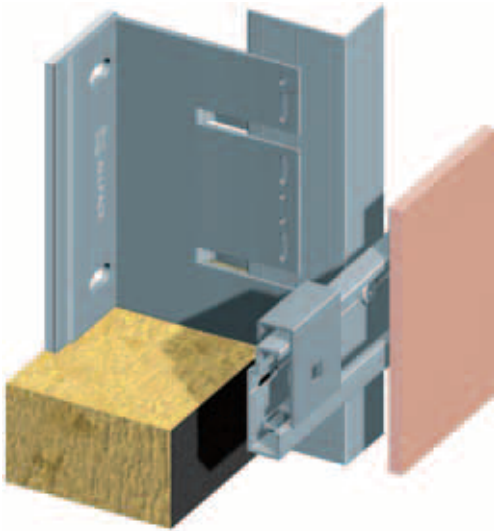

SYSTEM F3.40

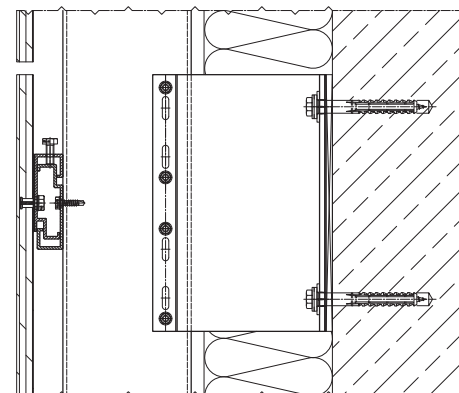
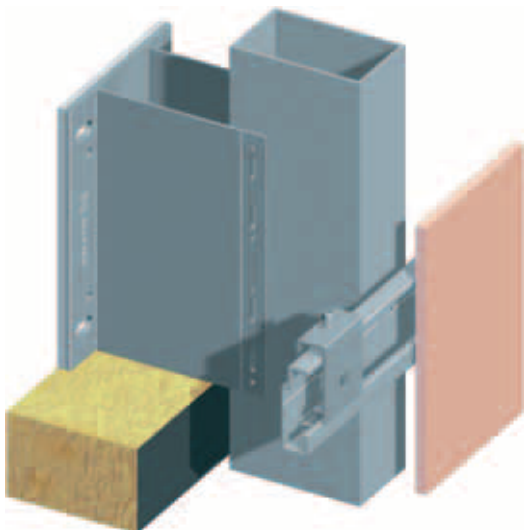

CONCEALED FIXING FOR HOOKING IN FACADE ELEMENTS

Fixing systems for hooking in facade elements have proven to be an efficient mounting method. Aluminium Composite (ACM) boards are especially well suited for this mounting method. To do this, the ACM boards are processed into cassettes and hooked into the fixing system and then secured against slipping.

SYSTEM F1.50

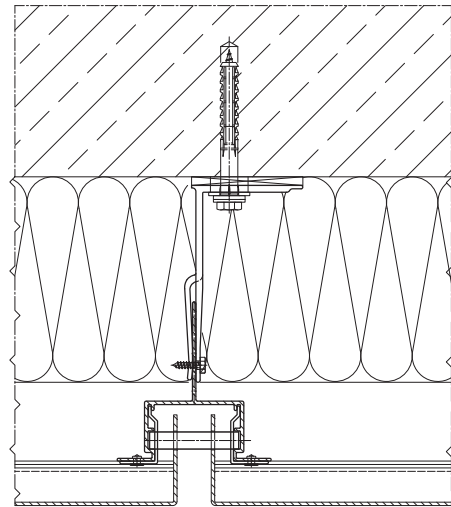
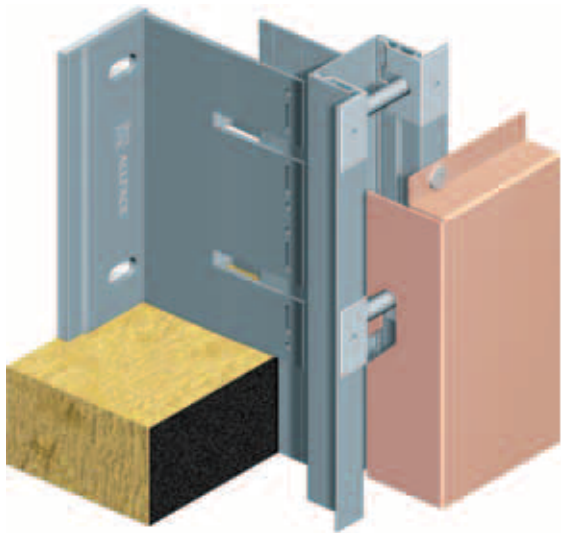

SYSTEM F2.50

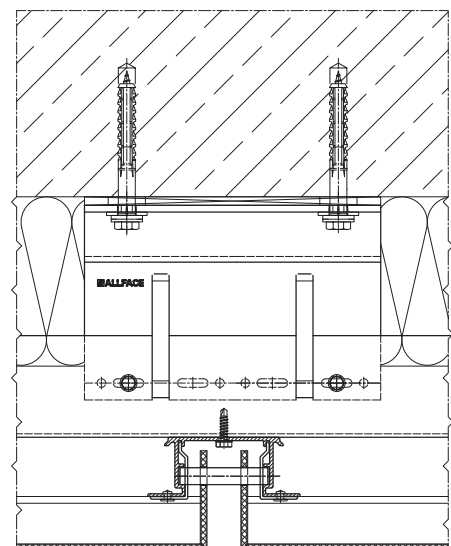
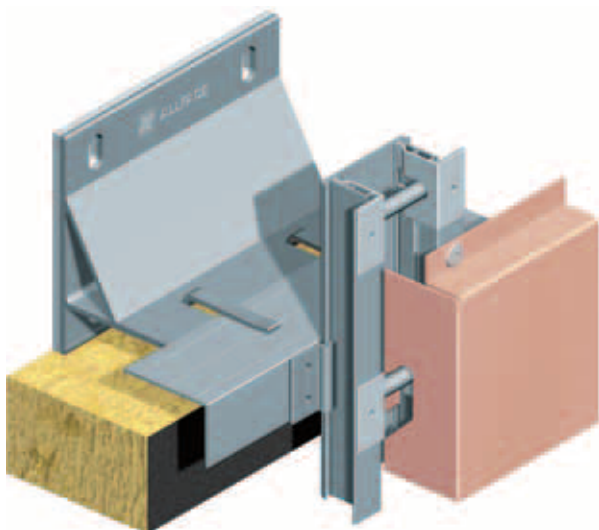



© MARK BUSSELL

WORLDWIDE SUPPORT

We simplify the complexity of facade design. The determination of the optimal fixing solution based on your detailed project information is done by us.

With our statics calculation programme, we comply with all required safety requirements and optimise the quantity of fixing elements that are used. This is a major contribution to the economic efficiency of the project.

Starting with the static calculations of the project, the installation plans are prepared for clear understanding and clarity, assisting in fast and easy installing.

By maintaining an open dialogue with our customers, we are able at the planning stage to point out difficulties and issues; providing solutions and possible improvements. Thus helping to save costs.

To help prepare your plans, we would be happy to provide CAD drawings with system details.

In addition, we will give you the appropriate templates for the specification.

We advise facade manufacturers and architects with regard to general and specific topics of Rainscreen. Importantly we also provide onsite training and support to the customer and installation teams.

The Allface Smart Fixing Systems contact with the customer is achieved through our international sales network. Customers benefit from our commitment to high standards of quality and service at all times.

Project Information Form

To prepare a meaningful offer, we need you to fill out the project information form. (See the project information form at www.plastestrip.com)

Guarantee

All systems are manufactured in accordance with EN 12020 and EN 755 and are statically provable. Allface is not liable for deficiencies in the facade elements or the installation. Local building regulations must be met.

Subject to technical changes.

© Allface 2010
Graphics:WERK1
Version: 12/10 en



From
Plastestrip Profiles
1-4 Enterprise Park
St Austell, Cornwall, UK, PL25 4EJ

T +44(0)1726 74771
F +44(0)1726 69238
sales@plastestrip.com
www.plastestrip.com