

RoofDek D135

0.75mm S320 steel. Interior liner finish¹

0.88mm S320 steel. Interior liner finish¹

1.25mm S320 steel. Interior liner finish¹

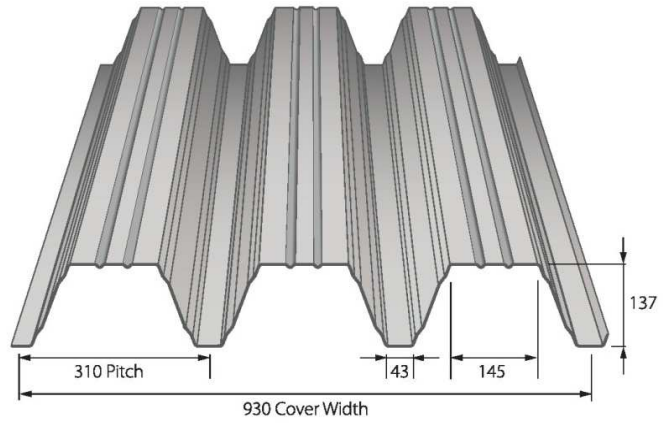

Ultimate Section Properties to Eurocode

Material specification	Design t mm	Weight kg/m ²	Broad flange in compression		Narrow flange in compression		100 mm Bearing on steel beam		Shear Capacity kN/m
			Moment Capacity kNm/m	Moment of Inertia cm ⁴ /m	Moment Capacity kNm/m	Moment of Inertia cm ⁴ /m	Transverse Resistance	Internal Rw kN/m	
0.75mm Steel S320 ¹	0.71	9.49	8.96	278.12	7.90	269.04	23.00	5.44	47.87
0.88mm Steel S320 ¹	0.84	11.14	11.36	333.92	10.23	326.48	32.17	7.78	65.34
1.25mm Steel S320 ¹	1.21	15.84	18.98	480.69	16.96	480.69	64.95	16.49	129.04

Safe Loads (kN/m²)

		Imposed load - deflection limit span / 200										Wind suction load - deflection limit span / 150							
		SPAN (metres)																	
		Span Condition	4.00	4.20	4.40	4.60	4.80	5.00	5.20	5.40	5.60	5.80	6.00	6.20	6.40	6.60	6.80	7.00	
0.75mm Steel S320 ¹	Imposed	Single	1.75	1.67	1.59	1.52	1.45	1.39	1.33	1.28	1.18	1.06	0.95	-	-	-	-	-	
		Double	2.05	1.91	1.78	1.66	1.55	1.46	1.37	1.29	1.22	1.15	1.09	1.03	0.98	0.93	-	-	
		Multi	2.21	2.10	2.00	1.91	1.83	1.75	1.64	1.55	1.47	1.39	1.31	1.25	1.18	1.13	1.07	1.02	
	Suction	Single	2.70	2.45	2.24	2.05	1.89	1.75	1.62	1.51	1.41	1.31	1.23	-	-	-	-	-	
		Double	3.05	2.77	2.53	2.32	2.14	1.97	1.83	1.70	1.59	1.48	1.39	1.30	1.23	1.16	-	-	
		Multi	3.79	3.45	3.15	2.88	2.65	2.45	2.27	2.11	1.97	1.84	1.72	1.62	1.52	1.43	1.35	1.28	
0.88mm Steel S320 ¹	Imposed	Single	2.52	2.40	2.28	2.18	2.09	2.00	1.81	1.60	1.42	1.27	1.14	1.02	0.92	-	-	-	
		Double	2.78	2.58	2.40	2.24	2.10	1.97	1.85	1.74	1.64	1.55	1.47	1.39	1.32	1.25	1.19	1.13	
		Multi	3.17	3.01	2.87	2.69	2.52	2.36	2.22	2.10	1.98	1.87	1.77	1.68	1.60	1.52	1.45	1.37	
	Suction	Single	3.48	3.17	2.89	2.65	2.44	2.26	2.09	1.94	1.81	1.70	1.59	1.49	1.41	-	-	-	
		Double	3.86	3.51	3.20	2.94	2.70	2.50	2.31	2.15	2.00	1.87	1.76	1.65	1.55	1.46	1.38	1.31	
		Multi	4.80	4.36	3.98	3.65	3.36	3.10	2.87	2.67	2.49	2.32	2.18	2.04	1.92	1.81	1.71	1.62	
1.25mm Steel S320 ¹	Imposed	Single	5.39	5.08	4.40	3.83	3.35	2.95	2.60	2.31	2.05	1.83	1.64	1.47	1.32	1.19	1.08	0.97	
		Double	5.12	4.75	4.41	4.11	3.84	3.60	3.37	3.17	2.99	2.82	2.66	2.52	2.39	2.27	2.15	2.05	
		Multi	6.12	5.69	5.29	4.94	4.62	4.33	4.07	3.83	3.61	3.41	3.23	2.91	2.64	2.39	2.17	1.98	
	Suction	Single	5.76	5.23	4.77	4.38	4.03	3.72	3.45	3.20	2.99	2.79	2.55	2.32	2.13	1.95	1.80	1.66	
		Double	6.43	5.84	5.33	4.89	4.50	4.15	3.85	3.58	3.33	3.11	2.92	2.74	2.58	2.43	2.29	2.17	
		Multi	8.01	7.28	6.64	6.08	5.60	5.17	4.78	4.44	4.14	3.87	3.62	3.40	3.19	3.01	2.84	2.69	

¹. Interior Liner finish

NOTES Black figures are stress limited, the load shown is the ultimate load divided by 1.5.

Blue figures are deflection limited.

Red figures show deck length exceeds 12m, these spans need extended end laps.

Calculations are to Eurocode, however additional checks such as fixings are required

A construction line load 1.5 kN/m has been allowed for.

Deck self weight has been allowed for, so does not have to be included in applied loads

Mar-16

T: +44 (0)1244 892 199

www.tatasteelconstruction.com