

Omega shower cubicle

Installation instructions

Please read carefully before installing the cubicle
If you require any further assistance please
contact Taplanes on 01423 771645

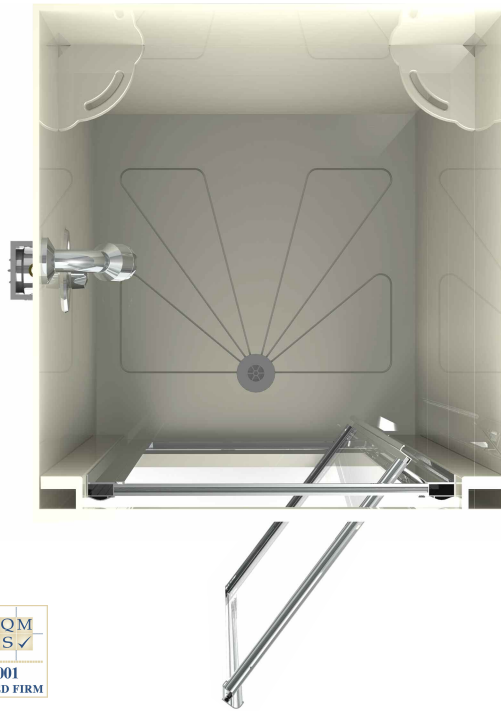

General

- The unit is delivered fully assembled in a protective cardboard sleeve.
- Approximate weight of unit without door is 65kg. With door 80kg.
- The unit will disassemble into four horizontal sections.
- No sealant should be used with polypropylene unless otherwise stated.
- If multiple units are delivered to site it is important to avoid intermingling the sections.
- Enough access should be allowed for moving the unit into position and tipping upright.
- Ensure that a minimum of 30mm is available above the cubicle height for final assembly.
- All shower fittings, lights and extraction should be installed using the relevant manufacturer's instructions.
- The cubicle arrives with a protective film. Where this may become entrapped during installation, localised removal will prevent unsightly traces of film on completion.
- Please take care not to scratch the internal surfaces.
- If other access holes below the level of the tray are required or enlarging existing holes, care must be taken not to damage the tray welds, especially at the corners, which could cause the cubicle to leak.
- Any large cut outs will undermine the integral strength of the unit, affecting its performance and invalidating any guarantees.

Omega shower cubicle

Installation instructions



TAPLANES[®]
SHOWERING SOLUTIONS

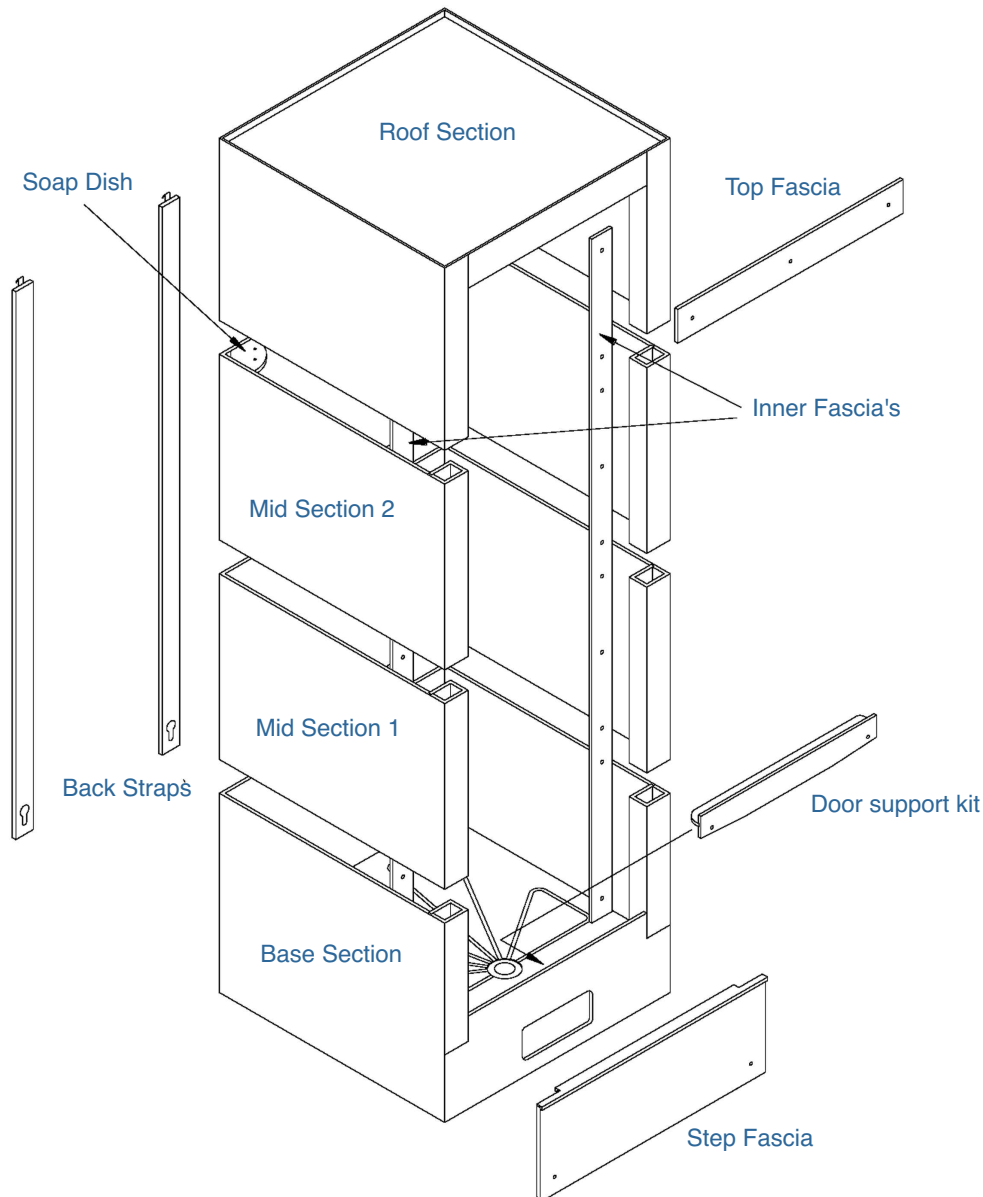

Installation

STAGE 1

- Remove the cardboard sleeve. Tear off a section and place in the cubicle as protection for the shower tray during installation.
- Disassemble the cubicle.
- Remove door if fitted.
- Unlatch the rear toggle clamps and detach the back straps.
- Remove inner fascia's and keep screws for reassembly.
- Unfasten screws from beneath the soap dishes.
- Remove top section. Take care not to damage the exposed joints.
- Do not use tools to prise the sections apart.
- Separate the mid sections from the base.

STAGE 2

- Transfer the cubicle to the installation location. Store sections on their side and keep parts together.
- Offer the base section into the location. If the floor is uneven it may be necessary to insert permanently fixed packing pieces under the base to level the cubicle.
- A gap of 75mm should be left at the rear of the cubicle for the operation of the toggle clamps. This can be reduced to 25mm by assembling the units and then pushing it back.
- Complete plumbing. See base detail.

BASE DETAIL

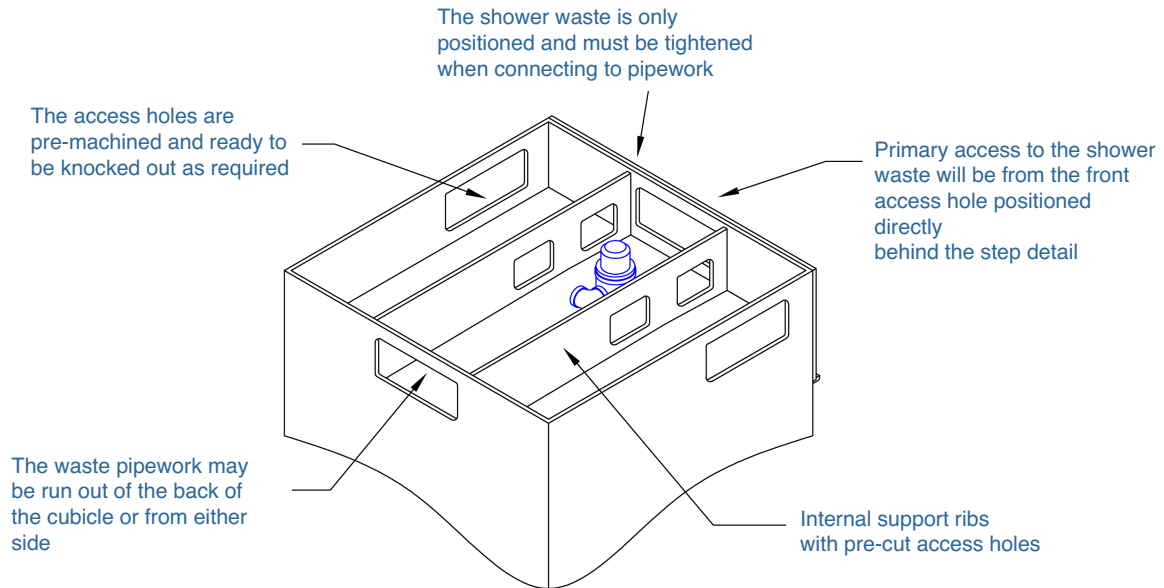

STAGE 3

- Fit back straps to lower section if access is limited.
- Secure base section in to position. The shower cubicle is not structurally dependent on the building and anchorage is recommended to protect the plumbing and stabilize for rough usage. Right angled brackets or batons may be used to fix the unit from the base section to the floor. Ensure that all screws are at least 25mm below the level of the cubicle floor. Cubicle may be screwed through flange above roof panel to a batten firmly secured to the building.
- Stack sections up. Ensure both side of the joint are clear of debris.
- A small bead of sealant, 2mm in diameter, can be placed at each corner of each section to aid sealing door.
- After positioning the third section connect the toggle clamps to the back straps to pull the sections together.
- Each section can be tapped in to place with a rubber mallet if required.
- After positioning the top section replace screws underneath soap dishes.
- Replace inner fascia's using the 3/4" self-tapping stainless steel screws.
- Fit door if required. Refer to the relevant instructions supplied to install door.
- If the unit is to have a door fitted please ensure the door is located behind the front step on the door support bracket.
- Do not fit the door to the top of the step detail as this would prevent access to the shower trap and prevent the door from containing the water spray within the unit.
- Remove any protective film. Refer to cleaning instructions supplied to remove any marks.
- Fit cover caps. All exposed screw holes are to be covered.
- If the product is supplied with a mixer console, please refer to local regulations with regards to the Legionella procedures for the mixer, shower head and associated pipework.

DIMENSIONS (mm):

720(w) x 770(d) x 2200(h)

770(w) x 770(d) x 2200(h)

WEIGHT: approximately 70kg \pm 10%

CLEANING

- We recommend a strong alkaline non-abrasive detergent/cleaner, preferably with a biocide, to clean the cubicle, followed by a thorough rinse.

Note: Care must be taken when using some of the propriety cleaners being marketed. Some are exothermic when mixed with water, and the excess heat could damage the plumbing.

- The design of the trap allows for easy cleaning by removal of the grid plate.

If you require any further assistance please contact Taplanes on 01423 771645