

T-T Enviro

PUMPING SYSTEMS

PTH 65
PTH 80K
PTH 150
PTH 80KK

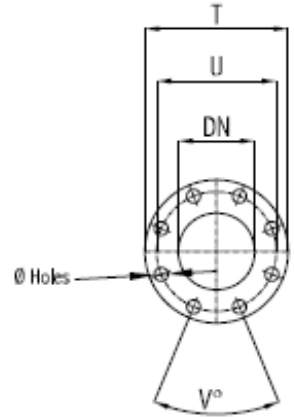
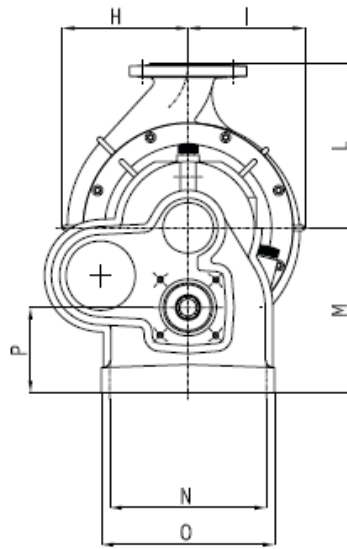
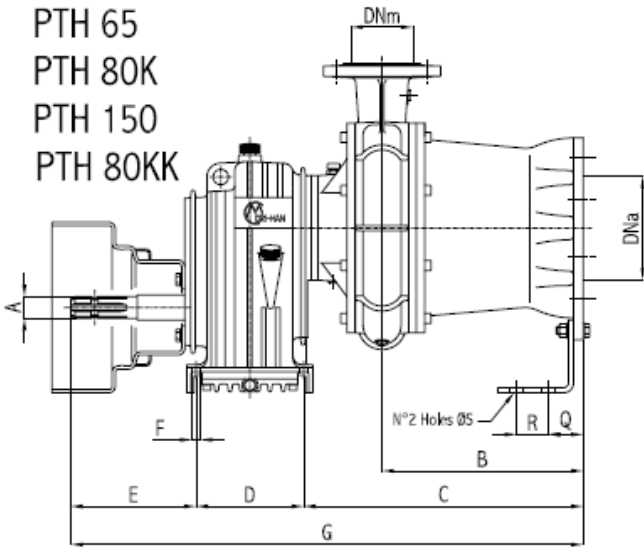

PTH 80
PTH 100

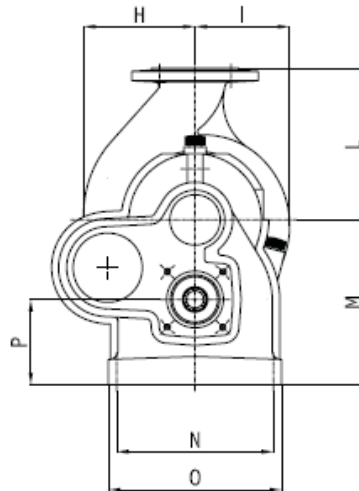
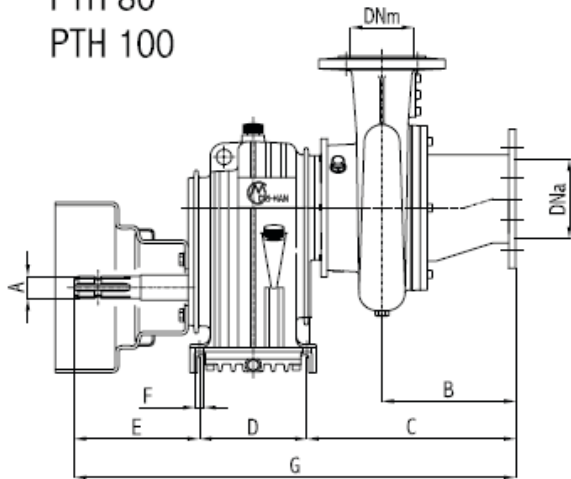

Flanges

DN	PN	T-	U	V°	DIAMETER	HOLES
65	10	185	145	90°	18	4
80	10	200	160	90°	18	4
80	16	200	160	45°	18	8
100	10	220	180	45°	18	8
150	10/16	285	240	45°	22	8
200	10	340	295	45°	22	8

PUMP TYPE	Overall Dimensions [mm]																		
	DNa	DNm	A	B	C	D	E	F	G	H	I	L	M	N	O	P	Q	R	ØS
PTH 65	DN150 - PN10	DN65 - PN10	1 3/8 z = 6	318	442	170	199	14	811	199	184	261	261	248	274	135	55	50	13
PTH 80	DN100 - PN10	DN80 - PN10		212	331				700	177	150	240					-	-	-
PTH 100	DN150 - PN10	DN100 - PN10		293	419				788	190	155	263					-	-	-
PTH 80K	DN150 - PN10	DN80 - PN16		335	501	895	248	229	370	296	265	300	152	55	50	13			
PTH 150	DN200 - PN10	DN150 - PN10/16		263	409	190	204	16	803								257	198	340
PTH 80KK	DN150 - PN10	DN80 - PN16		574	741	133	1064	248	229								370		

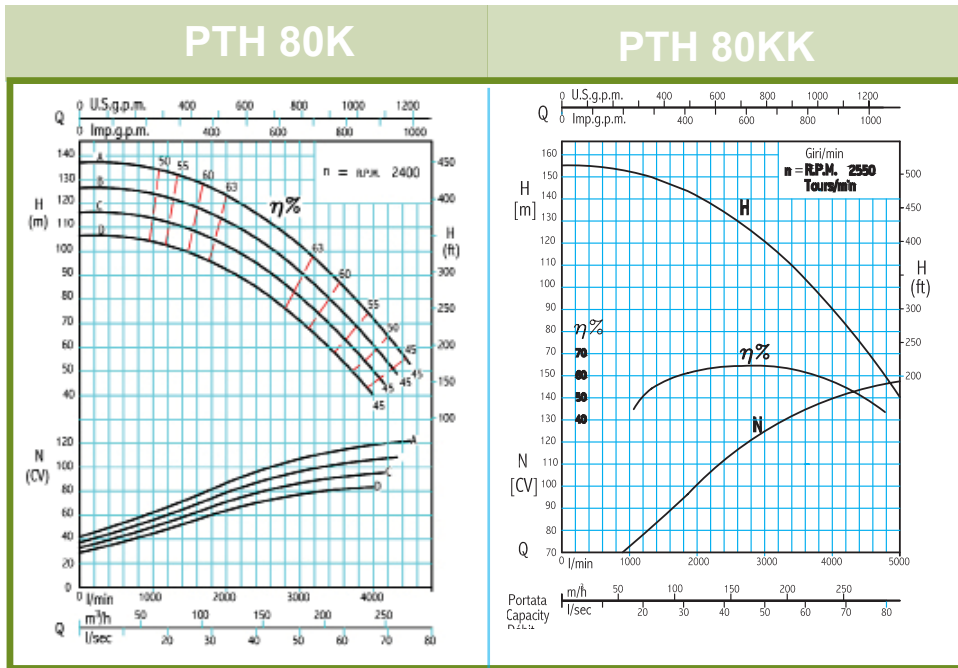
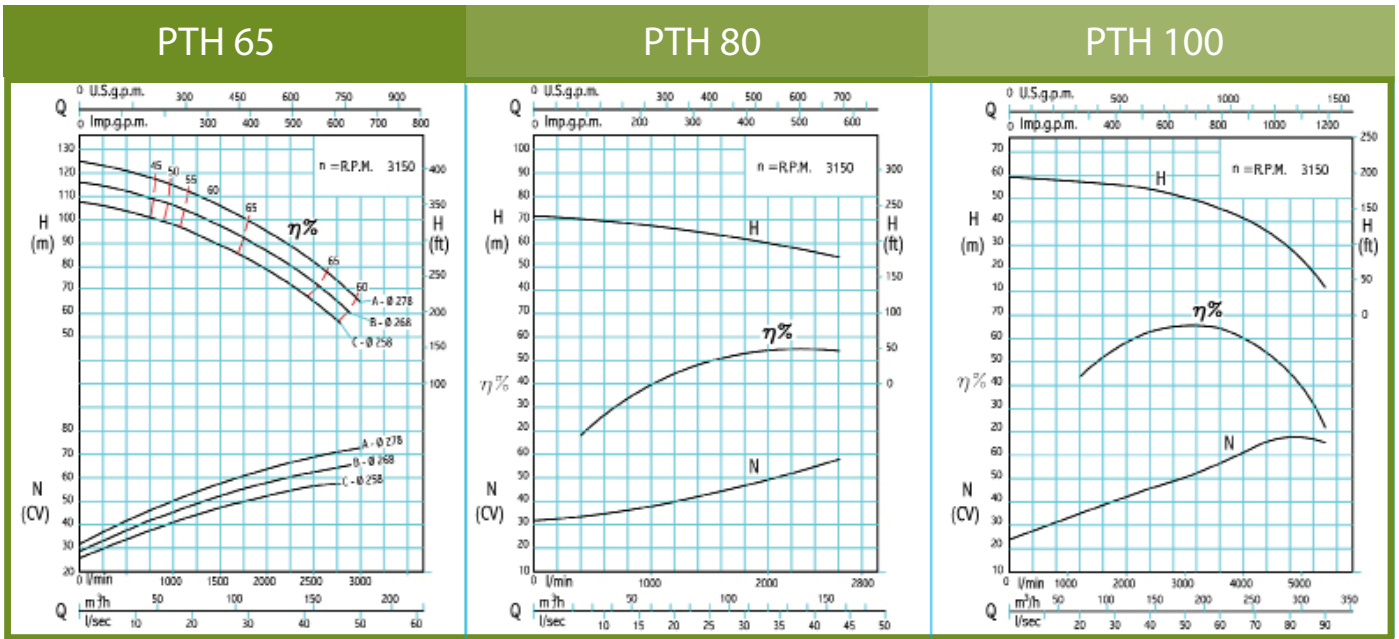

For more information on T-T's full agricultural and environmental product range please contact our sales team today.