

Flange UNI-PN6

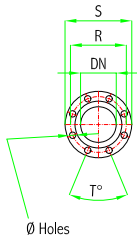

Flanges					
DN	R	S	T°	Ø Holes	n°Holes
80	150	190	90°	18	4
100	170	210	90°	18	4
150	225	265	45°	18	8
200	280	320	45°	18	8

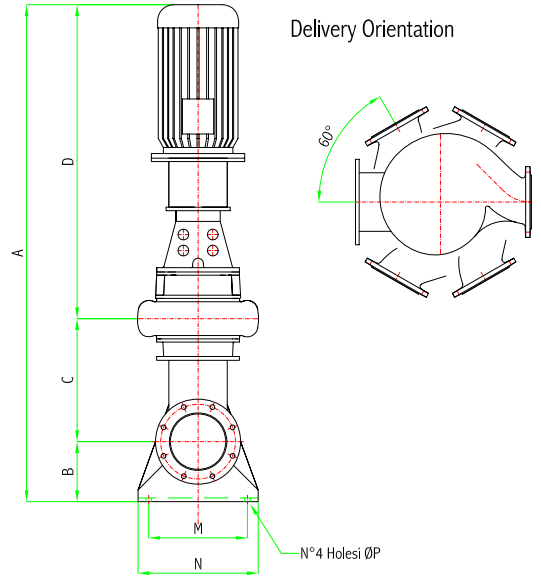
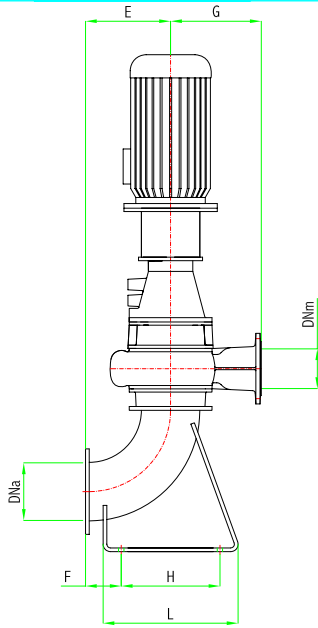

PUMP TYPE	Motor rating	R.P.M.	Suction	Delivery	OVERALL DIMENSIONS mm.											
	kW		n	DNa	DNm	A	B	C	D	E	F	G	H	L	M	N
ETV 15 - 80	15	2900	100	80	1452	150	338	964	166	63.5	239	205	285	205	245	16
ETV 18.5 - 80	18.5				1008											
ETV 22 - 80	22				731											
ETV 2.2 - 80	2.2				1219											
ETV 3 - 80	3				1237											
ETV 4 - 80	4	1450	150	100	1291	170	340	781	243	98	263	290	398	290	350	18
ETV 5.5 - 100	5.5				817											
ETV 7.5 - 100	7.5				875											
ETV 9 - 100	9				1092											
ETV 11 - 150	11				1773											
ETV 15 - 150	15	200	150	1817	225	456	1136	317	134	340	370	506	370	450	20	
ETV 18.5 - 150	18.5			1162												

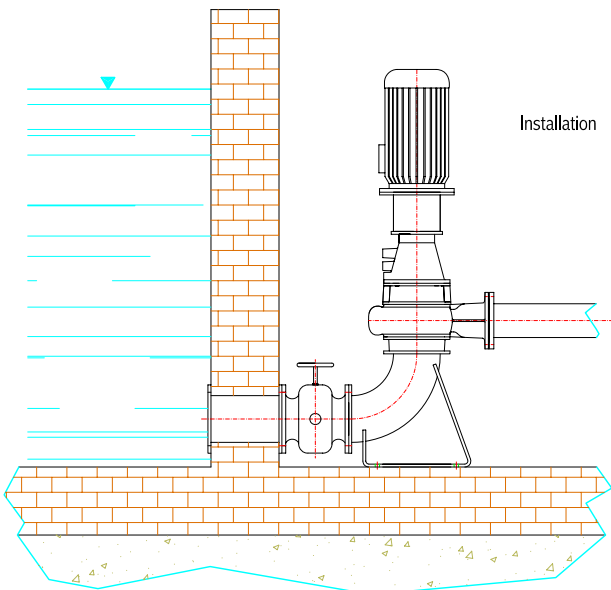

ACCESSORIES

PUMP TYPE	Flanged gate	Check valve
ETO ... - 80	DN 100 - PN 6	VRT 80
ETO ... - 100	DN 150 - PN 6	VRT 100
ETO ... - 150	DN 200 - PN 6