

Now includes
'A' rated window

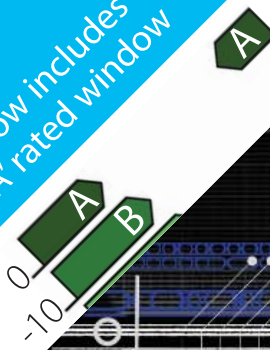

SPECIFICATION GUIDE

Effective from February 2008

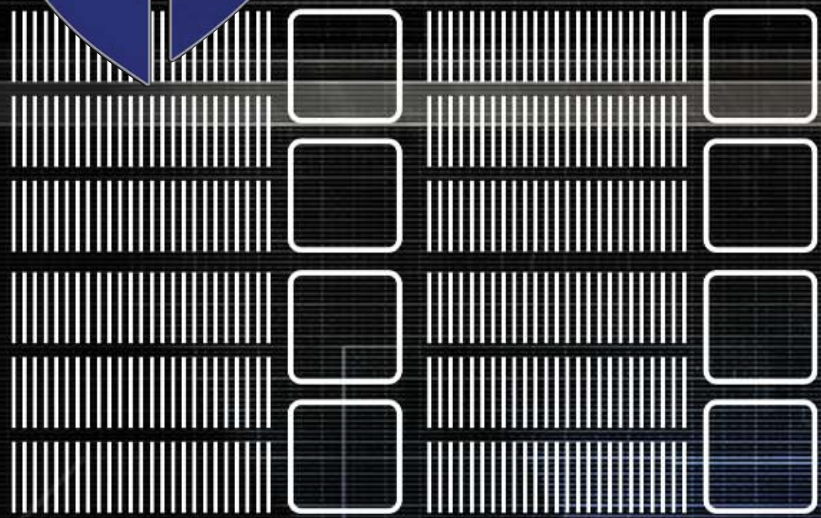

- TECHNICAL DATA
- ACCREDITATIONS
- SCHEMATICS
- FAQs





ABOUT SYNSEAL

Synseal is a systems company with a difference. It has been involved at all levels in the PVC-U window industry. It started in 1980 and within 18 months of opening the first shop, Synseal had opened 13 showrooms across the East Midlands. Later Synseal added a fabrication facility and by 1987 1,000 frames were being fabricated a week with a nationwide customer base. In 1991 Synseal started extruding profile.

The success of the fabrication business meant Synseal was in direct competition with some customers. That's why it pulled

out of the domestic market in 1991. And why it pulled out of fabricating in 1995. At that time Synseal was fabricating 2,200 frames a week. This business was sold to JBS Industries – and is still a strong business today.

Today Synseal is number one in windows and conservatories, an achievement no other company has attained. More fabricators choose Synseal than any other company. So it's hardly surprising that one-in-ten windows and one-in-four conservatory roofs are made with Synseal products.

The Shield window and door system was launched in 1999. This guide contains details of the accreditations, frequently asked questions, schematics and technical data.

In addition to the window system, Shield offers a conservatory roof system.



All information in this manual is provided for guidance only. Synseal Extrusions Ltd cannot be held responsible for the way in which the information in this manual is interpreted.

We reserve the right to alter specifications and descriptions without prior notice as part of our policy of continual development. All dimensions are in millimetres. Do not scale drawings.



CONTENTS

ACCREDITATIONS

Details of the accreditations that Synseal Extrusions Ltd. hold from recognised authorities

4

FAQs

Frequently Asked Questions relating to technical aspects, quality assurance and window/door/patio installation

5

SCHEMATICS

Cross section drawings of Shield windows and doors

Shield Window & Door Suite Components	6-7
Internally Beaded Casement Window and Externally Beaded Casement Window	8-9
Tilt & Turn Window and Patio Horizontal Cross Section	10-11
Double Door and Residential Door	12-13

TECHNICAL DATA

Technical data relating to various aspects of Shield windows and doors

Main Technical Details	14
Available Profile Colours	15
Thermal Expansion of PVC-U and Exposure Categories	16
'U' - Values and Energy Ratings (now includes 'A' rated window)	17
Safe Working Capacities of Reinforcements	18-20
PVC-U Windows in Fires	21
Sound Transmission Through Windows	22-23



ACCREDITATIONS

Synseal Extrusions Ltd. holds a number of accreditations (see right) from recognised authorities (British Standards Institution and the British Board of Agrément). To maintain registration, licenses and certificates, periodic on-site audits are carried out by the regulatory authority to inspect systems and where necessary take product samples for independent third party testing.



FM 31451

BSI - Registered to BS EN ISO 9001:2000, Certificate No. FM 31451 - Quality Management System Scope:- Manufacture and supply of a range of white and brown windows PVC-U profiles and beads for the fabrication of doors and windows. Manufacture of conservatory roofing systems to customer specified requirements.



BS EN 12608
KM 30983

BSI - Kitemark License No KM 30983 - Conforms with BS EN 12608 - specification for white PVC-U extruded hollow profiles with heat welded corner joints for plastic windows: materials type A.



BS7950/BS EN 12608
KM 41324

BSI - Kitemark License No KM 41324 - Conforms with BS7950/BS EN 12608 - specification for enhanced security performance of casement and tilt/turn windows for domestic applications in association with BS EN 12608.



BBA - Assessment report no. 1672 - Assessment of Shield outward opening PVC-U window system.



BBA - Assessment report no. 2519 - Assessment of additional profiles for the Synseal Shield opening PVC-U window system.

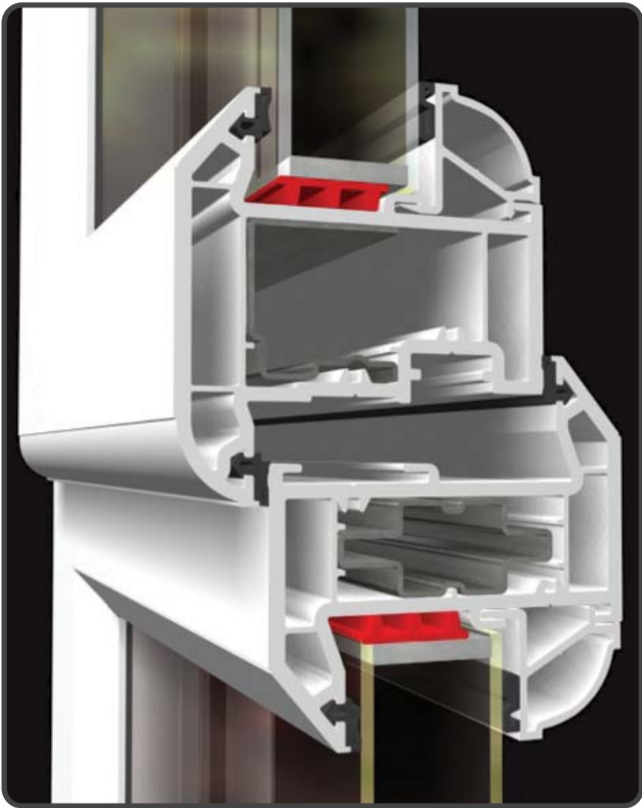

FAQs

TECHNICAL

QUALITY ASSURANCE

WINDOW/DOOR/PATIO INSTALLATION

What woodgrain finish do you use and do you offer other colours?
We offer Golden Oak, Mahogany and Cherrywood finishes (these are available internally/externally and also on white). The colours we offer are Anthracite Grey, Black Brown, Dark Red (Burgundy), Steel Blue (Oxford) and Dark Green (Brookland). Please contact the sales office for information.

What colour are Synseal's extruded products?
If matching door panels, the colour code nearest match for white profile is C121. If difficulty is experienced it is advisable to send a sample of profile to the door panel supplier.

What is the standard stack height for friction stays on Synseal Shield casement windows?
13mm is the standard.

What back-set espag or shootbolt will fit into Synseal casement?
A 22mm back-set espag or shootbolt will be fine.

Which back-set door lock is recommended?
35mm is recommended.

What exposure ratings do your windows achieve?
Up to 2400 pascals is achievable.

Do you offer the service of Patio Midrail End milling and how do I measure for Midrail length?
Yes, and we require the overall finished patio width (inc. number of panes).

For woodgrain on white windows how do I know which face to order?
The price lists and profile wallcharts clearly identify which faces are foiled by using A and B codes.

What are the size limitations and performance characteristics for the Synseal Shield PVC-U Casement Window System?
Please see the following table:

Window Type	Length (up to a maximum of)	Height (up to a maximum of)	Perimeter (up to a maximum of)	Transom/Mullion length including frame (up to a maximum of)	Exposure category as given in Table 1 of BS 7412:2002
Projecting top hung windows	1200mm	1200mm	-	-	2400 Special
Projecting side hung windows	650mm	1200mm	-	-	2400 Special
Fixed windows	2500mm	2500mm	8200mm	-	2400 Special
Multilight windows RA71 transom/mullion reinforcement	1500mm	1500mm	6000mm	1500mm	1600 Special
Multilight windows RS73 transom/mullion reinforcement	1800mm	1800mm	6000mm	1200mm	2000 Special

Can we use kitemark logo on our adverts?
No, use the phrase 'Our Windows are manufactured from profile supplied by Synseal Extrusions Ltd, which are Kitemarked to BS EN 12608 (Licence no. KM30983) and BS7950/BS EN 12608 (Licence no. KM41324)'

Does the profile have a BBA certificate?
No, but Synseal Shield profiles have been assessed by the BBA, Assessment report no. 1672 and no. 2519.

Can I make a half hour fire rated door from Synseal Extrusions?
No, as with all PVC-U profile, Synseal Extrusions achieve a class 1 surface spread of flame when tested to BS476 part 7.

Are PVC-U windows & doors load bearing?
No, but load bearing data is available for bay reinforcement RA75/SR06 (which are to be used in conjunction with Shield bay pole jack BPJS-RD and square corner jack BPJS-SQ).

Is there any regrind material in Shield window and door profiles?
All Shield window and door profiles are extruded from 100% virgin compound and are not diluted with second or more generation of reground extrusion profile.



Is it necessary to install Safety Glass in patio doors?
Yes, the use of safety glass in buildings is specified in a British Standard - refer to BS6262-4:1994. For further information, reference should also be made to Building Regulations Approved Document N - Glazing.

When replacing windows do Tricklevents need to be installed?
Yes, as of early 2006. Refer to Building Regulations Approved Document F - Ventilation.

Do I have to employ the services of a FENSA approved fitter when installing windows and doors?
No, but if non-FENSA approved fitters are used, then application to the local Building Control Office must be made to arrange appropriate inspection and approval. However, it is recommended that FENSA approved fitters are used.

Is it essential to have gas fires reserviced after fitting windows and doors?
No, but whilst it is not essential, this is always a good idea to ensure ventilation is still adequate.

When replacing timber windows and/or doors with PVC-U ones, do I need to check/replace as necessary the lintel above the removed windows/doors to maintain structural integrity?
Yes, PVC-U windows are not designed to be load-bearing.

What is the minimum size for a fire escape window?
The minimum size is an unobstructed openable area that is at least 0.33m² (minimum dimensions: 750mm high and 450mm wide or 450mm high and 750mm wide). The bottom of the openable area should not be more than 1100mm from the floor. See Building Regulations Approved Document B.





SCHEMATICS

KEY: = PLASTIC = ALUMINIUM = RUBBER = STEEL = FOAM = GLASS = SEALANT = VARIOUS/OTHER

Please note: Rolled In Gasket Option: SG89 - Black Gasket is available in white profiles only

CASEMENT SUITE COMPONENTS & REINFORCEMENTS

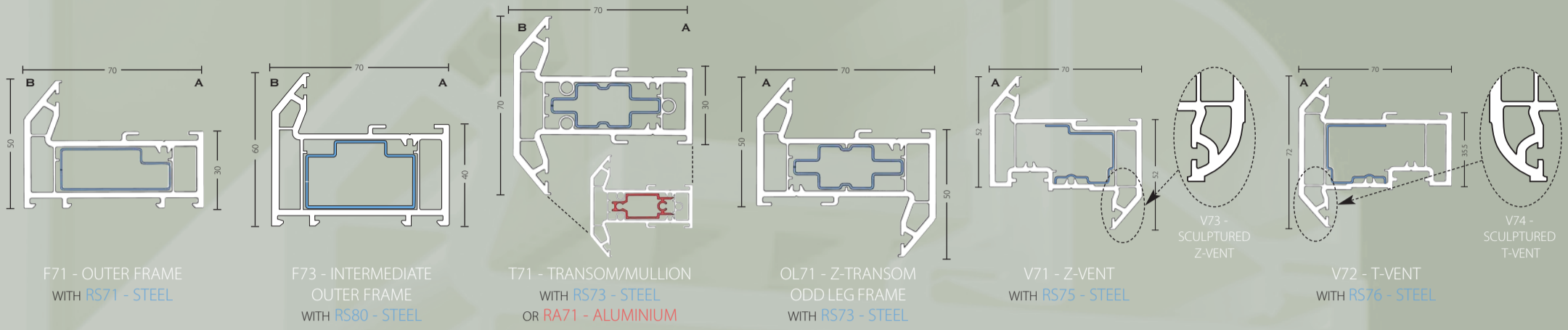

DOOR/TILT & TURN SUITE COMPONENTS & REINFORCEMENTS

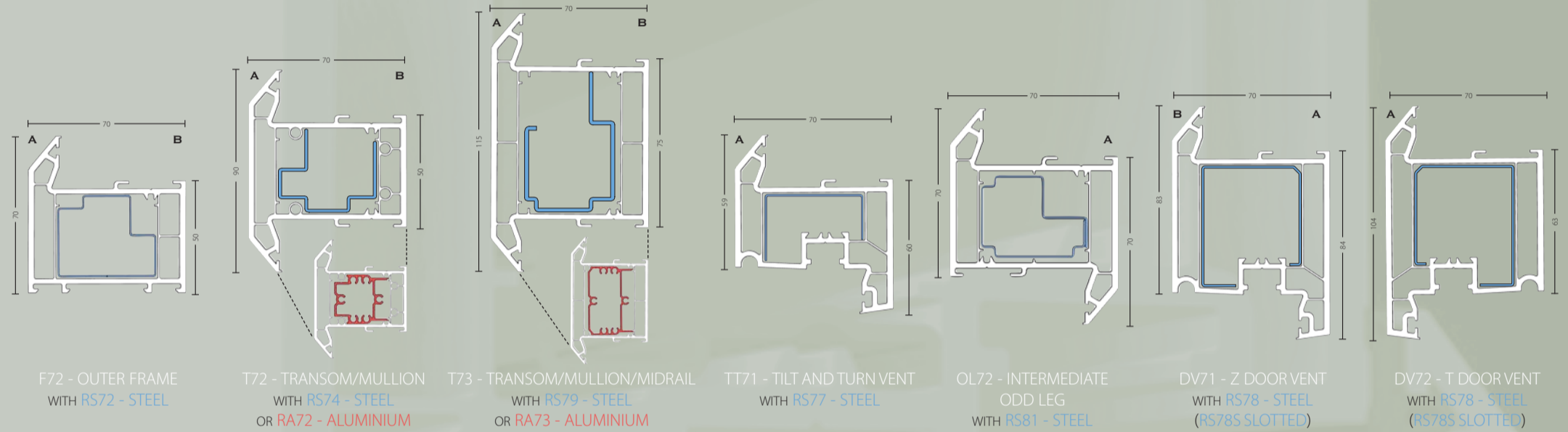

ALUMINIUM REINFORCEMENTS & BAY JACKS

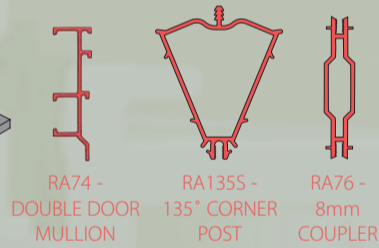
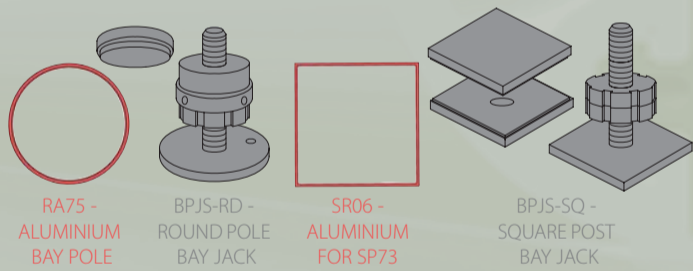

SILLS

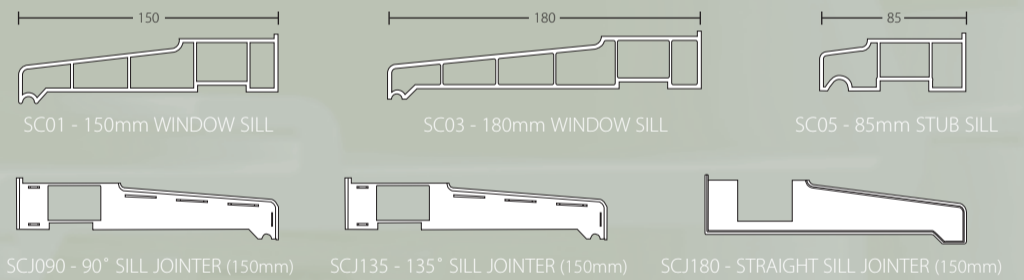

GLAZING BEADS

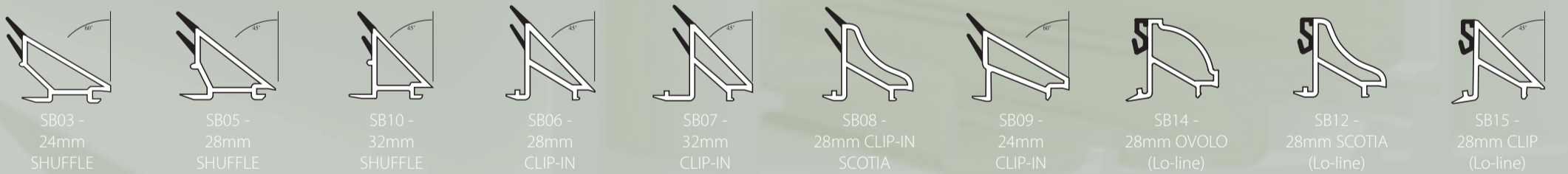

GASKETS



MOULDINGS & HARDWARE

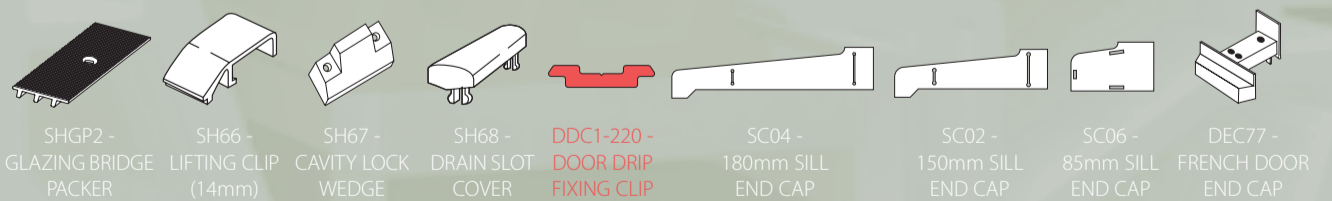

ANCILLARY PROFILES

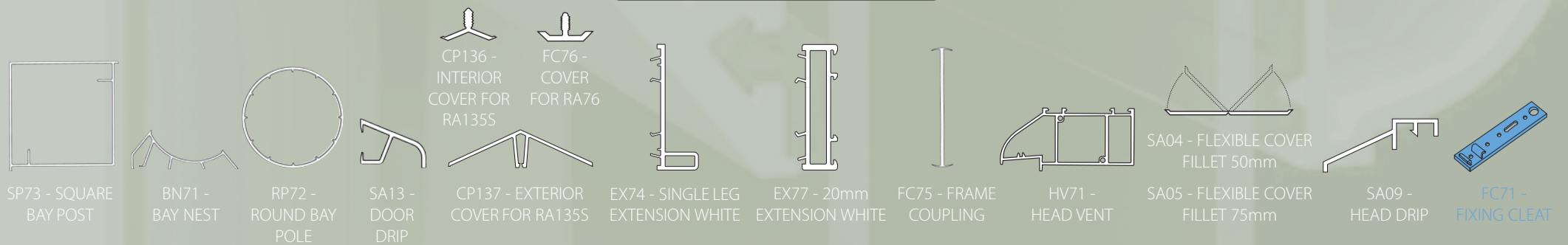

KEY: = PLASTIC = ALUMINIUM = RUBBER = STEEL = FOAM = GLASS = SEALANT = VARIOUS/OTHER

Please note: on both layouts different glazing options are available

INTERNALLY BEADED CASEMENT WINDOW

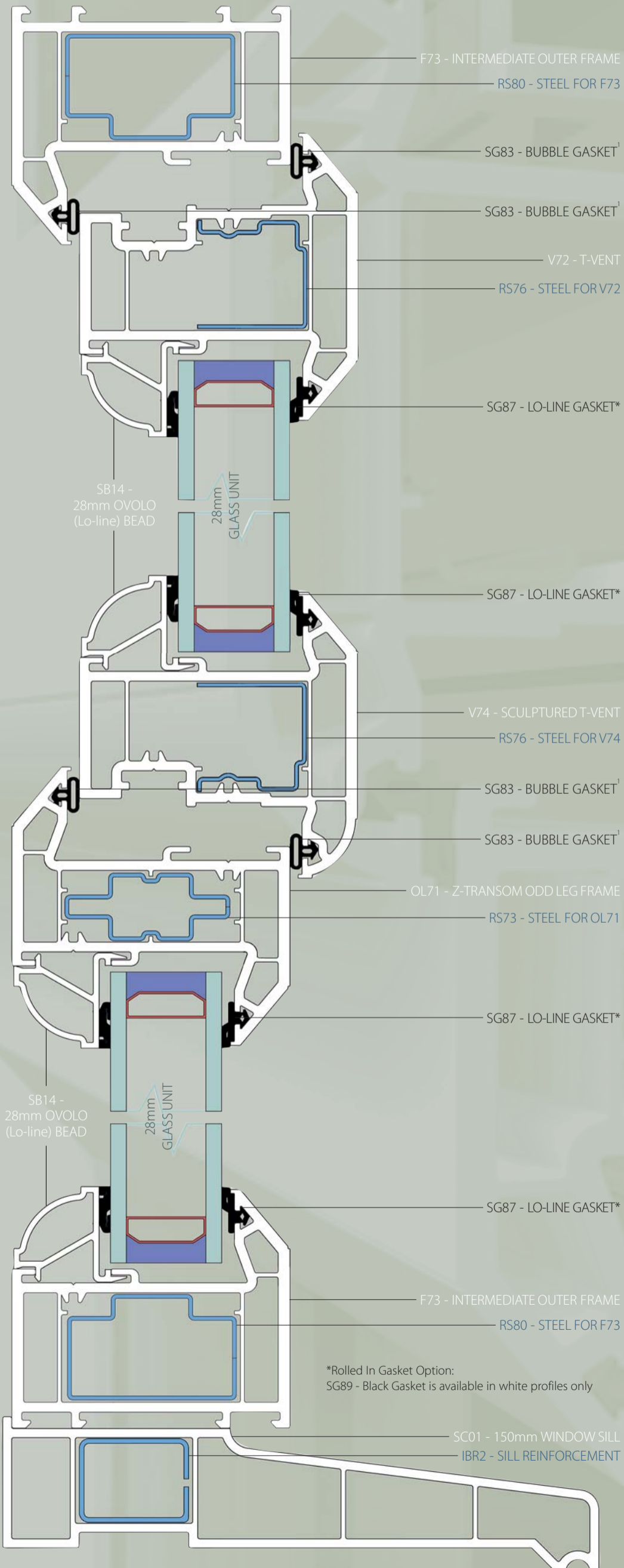

*Rolled In Gasket Option:
SG89 - Black Gasket is available in white profiles only

EXTERNALLY BEADED CASEMENT WINDOW

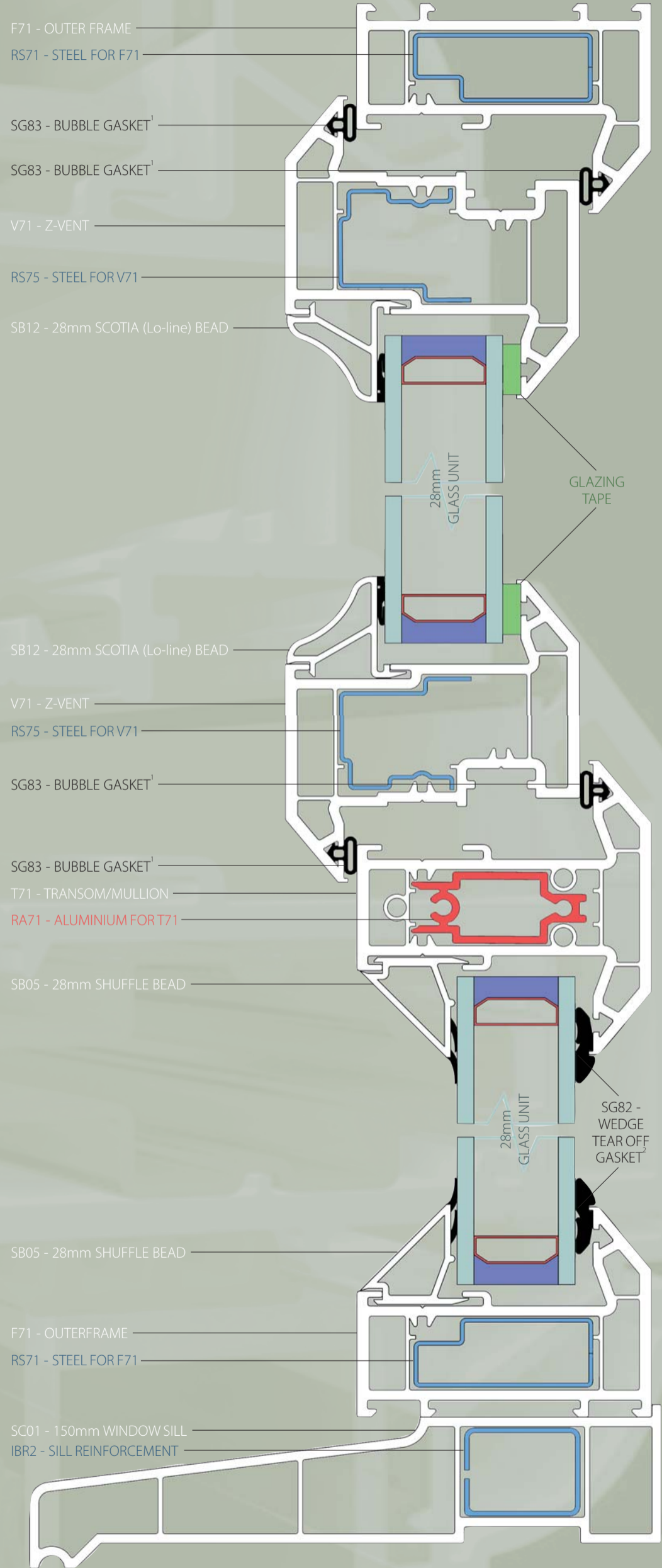

¹Weatherseal Gasket Option:
SG84 - FLIPPER SEAL GASKET can be used instead of SG83 - BUBBLE GASKET

²Option: SG85 - WEDGE TEAR OFF GASKET
can be used instead of SG82 - WEDGE TEAR OFF GASKET

KEY: = PLASTIC = ALUMINIUM = RUBBER = STEEL = FOAM = GLASS = SEALANT = VARIOUS/OTHER

Please note: on both layouts different glazing options are available

TILT & TURN WINDOW

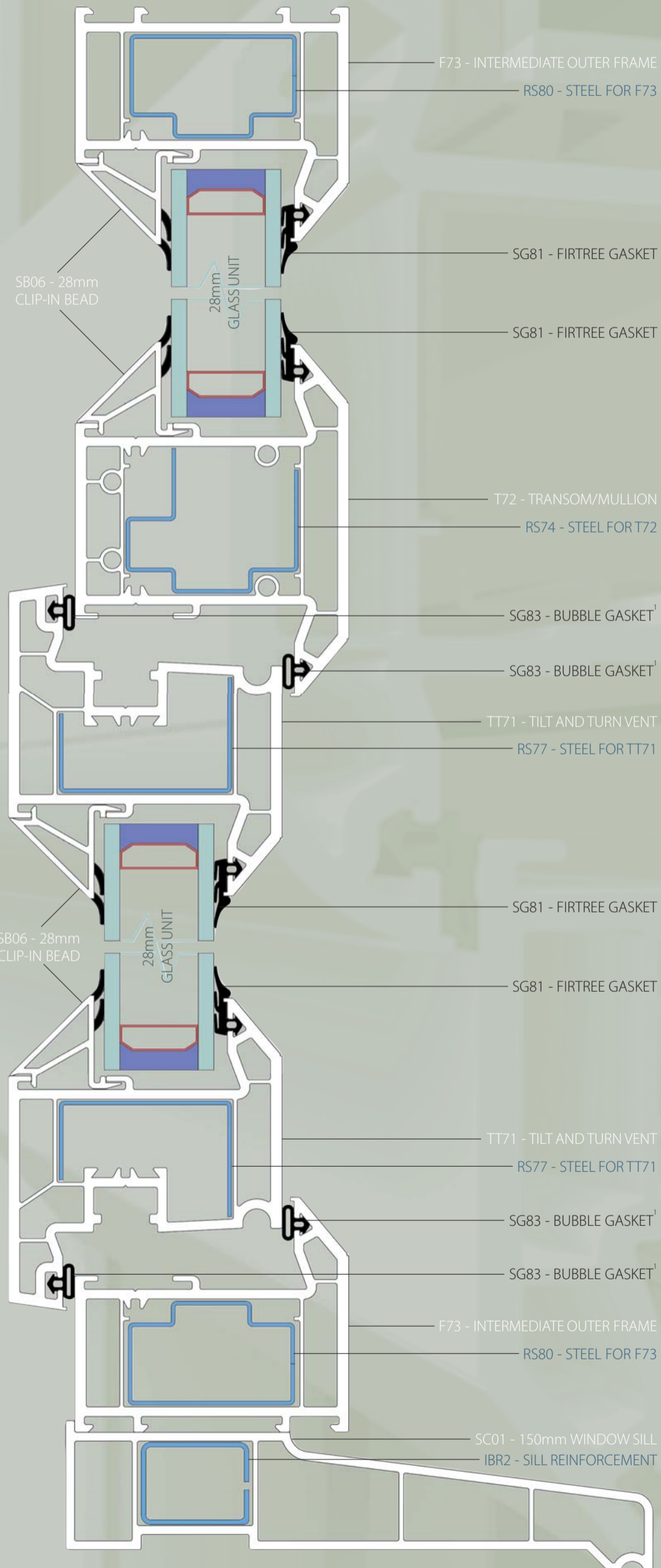

PATIO HORIZONTAL CROSS SECTION

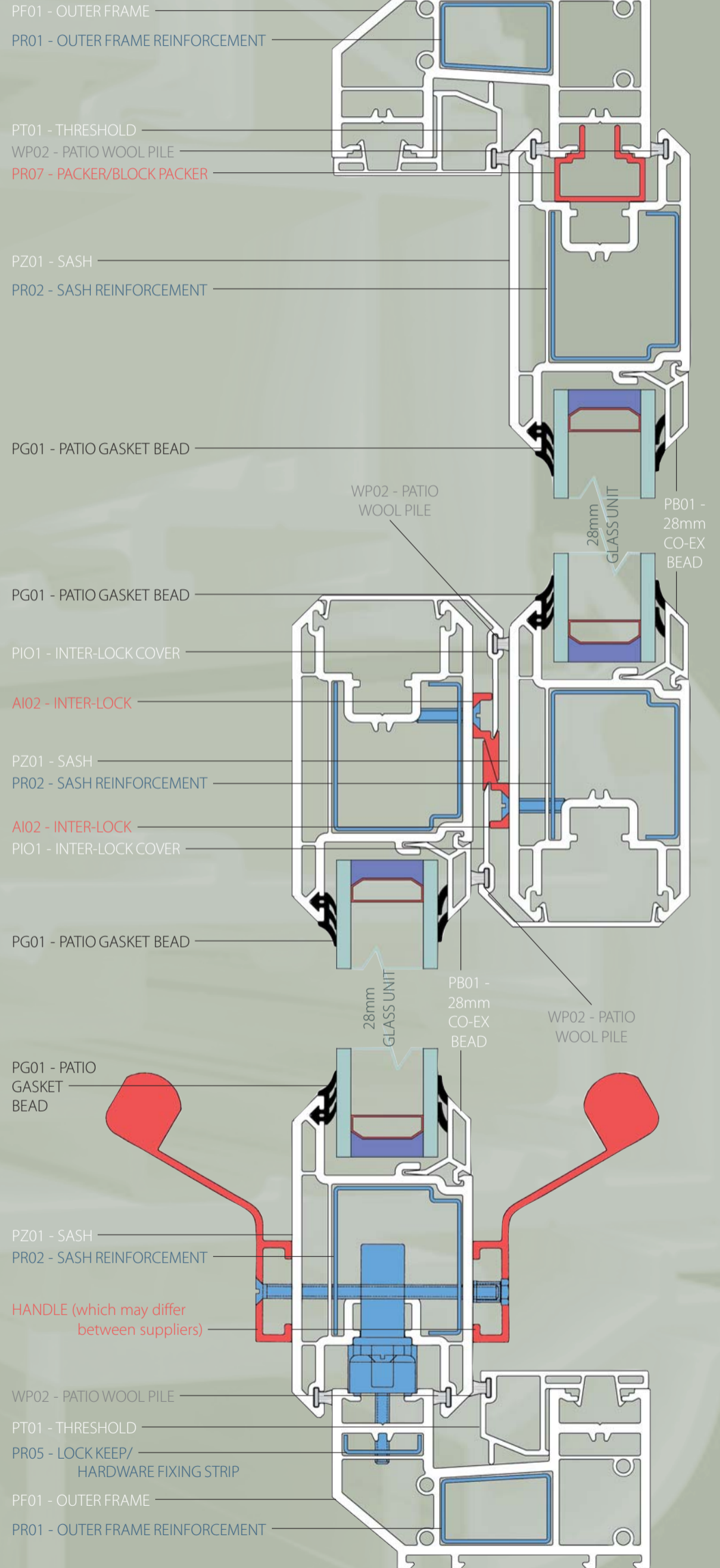

¹Weatherseal Gasket Option:
SG84 - FLIPPER SEAL GASKET can be used instead of SG83 - BUBBLE GASKET



SCHEMATICS

KEY: = PLASTIC = ALUMINIUM = RUBBER = STEEL = FOAM = GLASS = SEALANT = VARIOUS/OTHER

Please note: on both layouts different glazing options are available

DOUBLE DOOR

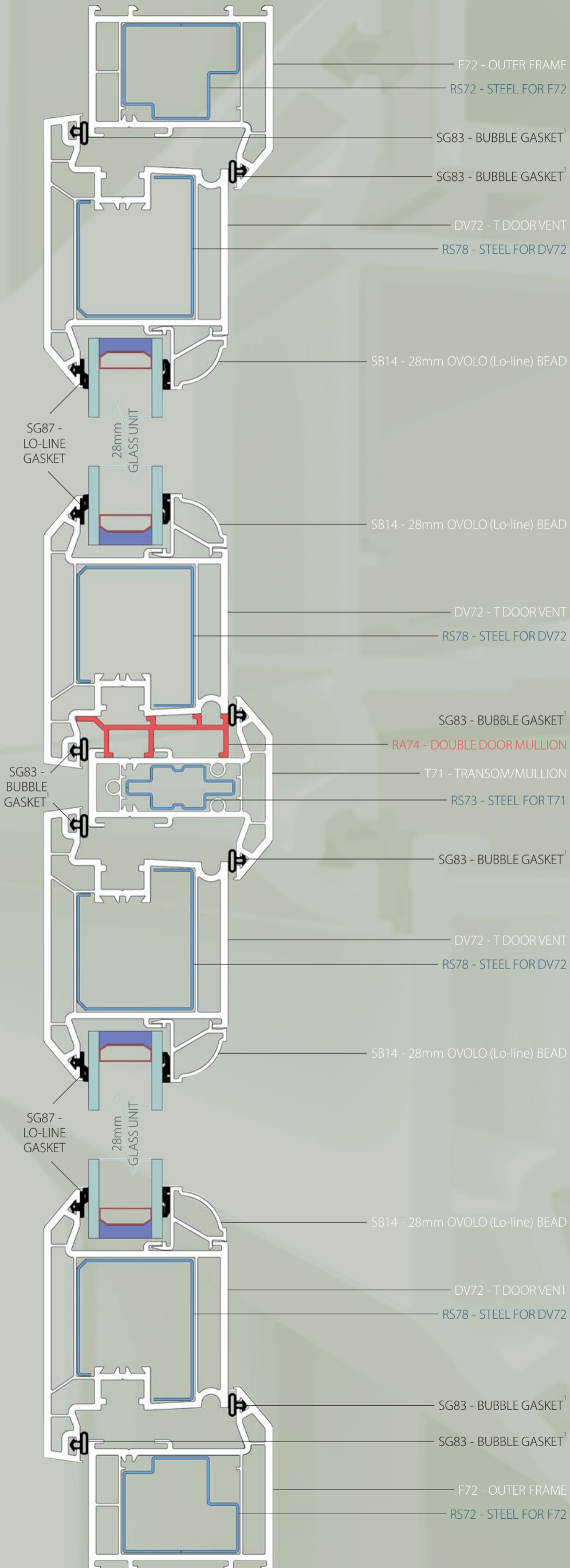

RESIDENTIAL DOOR

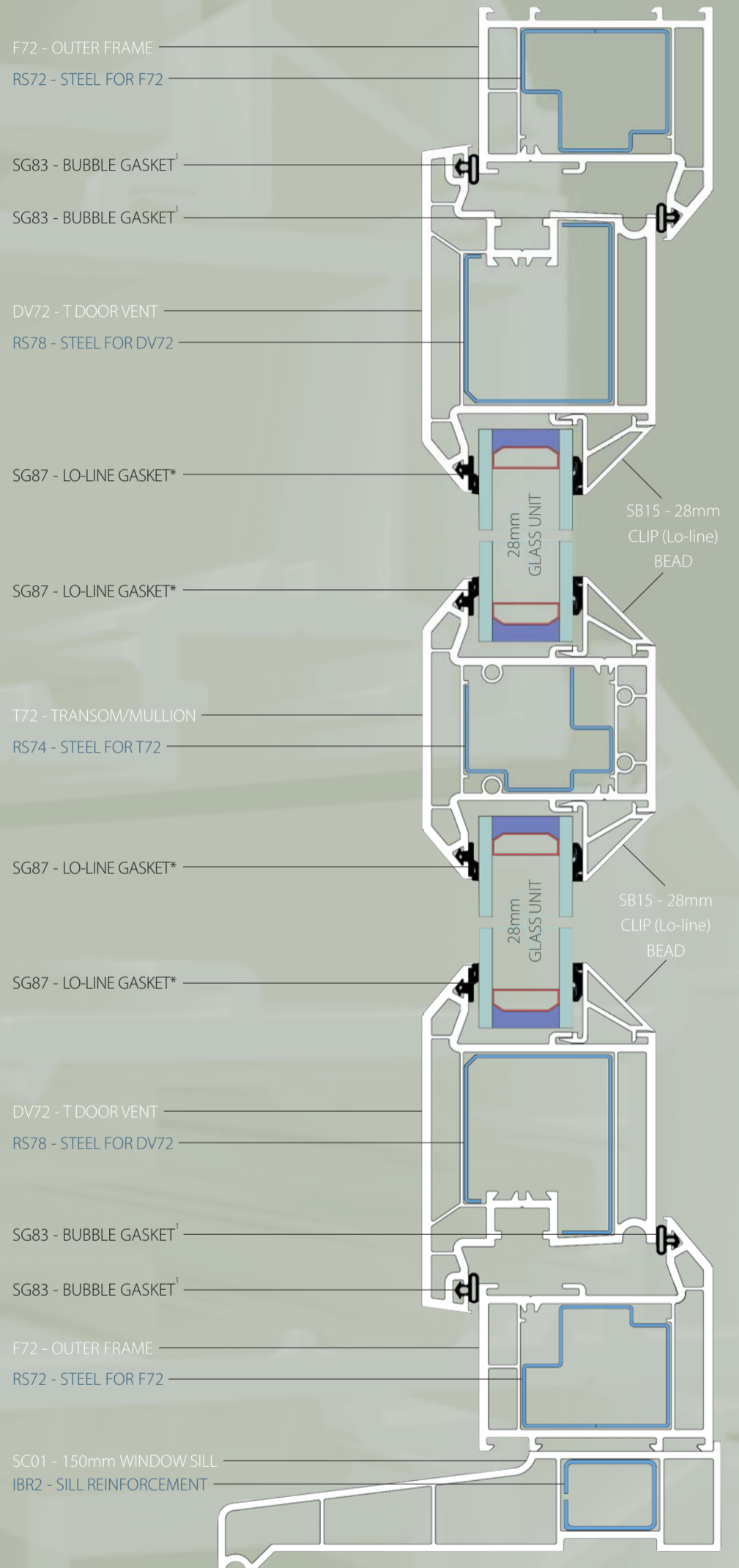

*Rolled In Gasket Option:
SG89 - Black Gasket is available in white profiles only

¹Weatherseal Gasket Option:
SG84 - FLIPPER SEAL GASKET can be used instead of SG83 - BUBBLE GASKET

MAIN TECHNICAL DETAILS

Name:	Shield 3mm System for windows and doors
Grade Reference:	SYN10 White 01
Material:	Acrylic modified high quality impact resistant, white unplasticised Polyvinyl Chloride extrusion to produce a rigid multi-chamber extrusion.
Physical Properties:	Comply with BS EN 12608 2003
Colours:	Mahogany, White, Cherrywood, Golden Oak, Anthracite Grey, Black Brown, Dark Red (Burgundy), Steel Blue (Oxford) and Dark Green (Brookland)
Appearance:	Smooth, White, Non-porous gloss surface/Woodgrain
Surface Finish:	Stabilised against UV light to prevent excessive colour shift. Meets requirements of BS EN 12608 when used in the EU Moderate climate.
Weldability:	For the determination of the weldability of profiles, welded corners are tested in accordance with EN514. The calculated mean stress at maximum of each corner shall not be <math><25 \text{ N/mm}^2</math> for the tensile bending test of 35 N/mm ² for the compression bending test. Each individual value shall not be <math><20 \text{ N/mm}^2</math> for the tensile bending test and not be <math><30 \text{ N/mm}^2</math> for the compression bending strength.
Glass & Glazing:	Subject to manufacture in accordance with the Synseal Technical Manual recommendations, the casement window system will conform to the requirements of the standard.

Physical Properties of PVC-U Type A Material Grade Ref: SYN10 White 01

Sound Insulation:	30db minimum
Thermal Conductivity at 20°C:	Typical test value 0.16 W/M deg C. PVC-U has a low thermal conductivity and virtually constant over a wide temperature range.
Heat Reversion:	To BS EN 12608 Clause 5.5 (Test method: 1hr at 100°C). When tested in accordance with Appendix E, the mean maximum reversion value for individual samples shall not be greater than 2% for profiles and glazing beads. The variation between individual face sides of the same sample shall not be greater than 0.4% for profiles and 0.6% for glazing beads.
Heat Ageing:	To BS EN 12608 Clause 5.7 (Test method 30 mins at 150°C). When tested in accordance with Appendix F, the profile shall show no bubbles, cracks or de-lamination.
Resistance of impact at low temperature:	To BS EN 12608 Clause 5.6 Class 2. (Test method: 1kg from 1.5 metres at -10°C). When mainframe, sub-sill casement and sash profiles are tested in accordance with EN 477, no more than one sample shall exhibit cracking through the entire wall thickness of the profiles on either face.
Heat Resistance/Softening Point:	To BS EN 12608. When tested to ISO 306 method B. Minimum vicat 5kg softening point 75°C. Typical result 82°C. This is well above the requirements of the UK and German specifications.
Apparent Modulus of Elasticity:	To BS EN 12608 minimum requirement 2200 mpa value, when tested to ISO 178. Typical result 2350 mpa.

Retention of Impact Strength after Artificial Ageing:	To BS EN 12608 2003. Minimum 60% of original value specified when tested to EN 513
Colour Fastness:	After exposure in accordance with EN 513 moderate EU climate zone, the change in colour between the unexposed test specimens expressed in ΔE^* shall not be >5 & Δb^* not >3. The determination of the change in colour is in accordance with EN 513.
Bulk Density of Powder Blend:	Typical test value 0.63 - 0.64. Minimum requirements: None specified.
Specific Gravity of Profile:	Typical test 1.472 6ms c.c. Minimum requirement: None specified.

PROFILE STORAGE

Prefabricated Storage:

The profiles should be stored in a suitable area, preferably under cover NOT in moist conditions or direct sunlight. If the profile is stored on racking, it must be supported at least 1 metre intervals of the entire profile length. If stored on the floor, the floor must be level and the profile placed on a protective board base.

The ideal factory/storage temperature should be maintained between 17°C and 20°C as working with profiles in colder conditions can lead to undue weld stress. If the profile has been stored in a separate storage area with lower temperature, at least one hour per °C should be allowed for the profile to reach workshop temperature.

Profile cut ready for welding shall be stored in a dry area with the same ambient temperature of 17°C - 20°C. Care shall be taken if profiles are stored vertically so as not to damage the point of the mitres (check contamination of these points prior to welding). All cut profiles must be welded within 48 hours as this will avoid contamination of the cut ends and avoid any absorption of moisture, which could have an effect on the weld strength.

AVAILABLE PROFILE COLOURS*



White
C121



Mahogany
(Also available for roofs)
2097013



Golden Oak
(Also available for roofs)
80001



Cherrywood
(Also available for roofs)
8015/16/17



Dark Green (Brookland)
6125



Anthracite Grey
7016

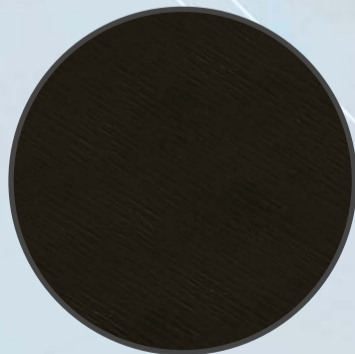

Black Brown
8518

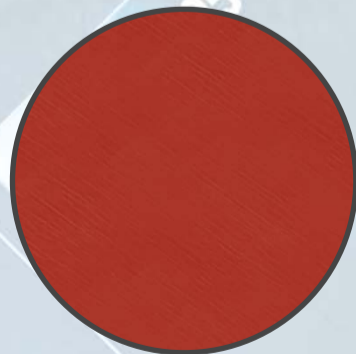

Dark Red (Burgundy)
3081

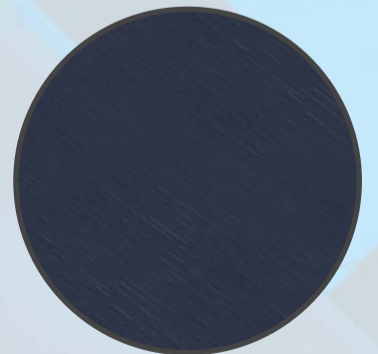

Steel Blue (Oxford)
5150

*Please note: the swatches on this page should be used as a guide only and are as accurate as our printing process allows

THERMAL EXPANSION OF PVC-U

(Information from Tangram Technology Ltd)

The linear thermal expansion of a material is a measure of how much that material will expand for each 1 degree change in temperature.

Typical values:

PVC-U:	0.0000600/°C
Mild Steel (0.06 carbon):	0.0000126/°C
Aluminium (99 % pure):	0.0000240/°C

The values of the coefficient of thermal expansion can be regarded as constant over the temperature range normally experienced in the U.K.

A temperature difference between the inside and outside surfaces can lead to differential thermal expansion, which may in some circumstances lead to buckling or distortion.

The bulk temperature of the material is usually used to calculate the expansion. This is not always the same as the surface temperature.

For white profile the temperatures are approximately the same, but for dark (woodgrain) profiles the bulk temperatures may be higher than the air temperature due to the higher solar heat gain of dark profiles. Expansion gaps should always be larger for woodgrain profiles than for white profiles to allow for this.

Calculation example:

If a 1000 mm length of PVC-U profile is heated up from 20°C to 40°C, then the expansion is given by:

Original length X change in temperature X coefficient of thermal expansion, i.e.

$$1000 \times 20 \times 0.00006 = 1.2 \text{ mm.}$$

Therefore the final length of the PVC-U profile is 1001.2 mm.



EXPOSURE CATEGORIES

Exposure Category (design wind pressure) Pa	Air Permeability Pa	Water-tightness Pa	Wind Resistance Pa
800	up to 200	200	800
1200	up to 200	200	1200
1600	up to 300	200	1600
2000	up to 300	200	2000
over 2000 (state design wind pressure)	up to 300	300	equal to design wind pressure

Conversion Table - Wind Pressure and Speed

Pressure		Speed		
Pa	lb f / ft ²	m/s	km/h	m.p.h.
800	16.4	35.6	129	80
1200	24.55	43.6	157.5	98.3
1600	32.75	50.4	181	113
2000	40.9	56.3	202.5	126.5

Note:

The above conversions are based on the aerodynamic relationship:

$$\text{Pressure} = (\text{velocity})^2 \times (\text{a constant})$$

For design wind pressures these values must be multiplied by a shape factor.

'U'-VALUES AND ENERGY RATINGS

(From computer simulations)

'A' rated Shield Window

PVC-U narrow frame F71 with minimum steel reinforcement to BFRC requirements with 4-16-4 Low-E 0.04 uncorrected emissivity (Saint Gobain Planitherm Total), 90% Argon 10% Air filled, low-iron (Saint Gobain Diamant) glazing unit with Superspacer warm edge spacer bar with 5mm hot melt butyl secondary seal

Energy Index (kWh/m ² /year) (Energy Index certified by BFRC and based on UK standard window. The actual energy consumption for a specific application will depend on the building, the local climate and the indoor temperature)	+0
The climate zone is:	UK
Thermal Transmittance (U _{window})	1.40 W/m²K
Solar Factor (g _{window})	0.44 W/m²K
Effective Air Leakage (L _{factor})	0 W/m³K

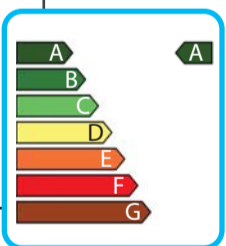

Shield Window, OptiWhite, Argon, K-glass & Edgetech Super Spacer

Part (see Fig 1)	Δψ m	A m ²	U ₁ W/m ² K	U ₂ W/m ² K	U _p W/m ² K	U _f W/m ² K	Ψ W/m-K	Φ _f W/K
1	1.3665	0.0808	1.1340	1.6352	1.0309	1.4792	0.0291	0.1593
2	0.4945	0.0315	1.1340	1.6352	1.0309	1.4792	0.0291	0.0610
3	0.4945	0.0315	1.1340	1.6352	1.0309	1.4792	0.0291	0.0610
4	1.2785	0.1389	1.2408	1.6618	1.0309	1.6367	0.0279	0.2631
5	0.4505	0.0537	1.1963	1.6197	1.0309	1.5083	0.0286	0.0938
6	0.4505	0.0537	1.1963	1.6197	1.0309	1.5083	0.0286	0.0938
7left	1.3665	0.1786	1.2039	1.6895	1.0309	1.7196	0.0574	0.3831
7right	1.2785				1.0309			
Σ Δψ=	7.1800						Ψ _{av} =	0.0287
Glass	D mm	A m ²	U _g W/m ² K		Φ _g W/K			
Left	28	0.6757	1.5284		1.0328			
Right	28	0.5760	1.5284		0.8803			

Window 'U' - Value = **1.6635 W/m²K**

Domestic Window Energy Rating (DWER)

Pane	g _L	% glass	F _w	g _w	L factor W/m ² K	DWER kWh/m ² /Yr
Left	0.78	38.40	0.9	0.5000	0.00	-4.65
Right	0.78	32.83	0.9	0.5000	0.00	-4.65

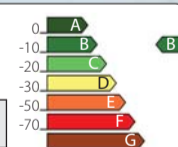

Shield Window, Argon, K-glass & Edgetech Super Spacer

Part (see Fig 1)	Δψ m	A m ²	U ₁ W/m ² K	U ₂ W/m ² K	U _p W/m ² K	U _f W/m ² K	Ψ W/m-K	Φ _f W/K
1	1.3665	0.0808	1.1340	1.6563	1.0309	1.4792	0.0290	0.1591
2	0.4945	0.0315	1.1340	1.6563	1.0309	1.4792	0.0290	0.0609
3	0.4945	0.0315	1.1340	1.6563	1.0309	1.4792	0.0290	0.0609
4	1.2785	0.1389	1.2408	1.6795	1.0309	1.6367	0.0277	0.2628
5	0.4505	0.0537	1.1963	1.6375	1.0309	1.5083	0.0284	0.0937
6	0.4505	0.0537	1.1963	1.6375	1.0309	1.5083	0.0284	0.0937
7left	1.3665	0.1786	1.2039	1.7099	1.0309	1.7196	0.0571	0.3826
7right	1.2785				1.0309			
Σ Δψ=	7.1800						Ψ _{av} =	0.0285
Glass	D mm	A m ²	U _g W/m ² K		Φ _g W/K			
Left	28	0.6757	1.5565		1.0518			
Right	28	0.5760	1.5565		0.8965			

Window 'U' - Value = **1.6822 W/m²K**

Domestic Window Energy Rating (DWER)

Pane	g _L	% glass	F _w	g _w	L factor W/m ² K	DWER kWh/m ² /Yr
Left	0.72	38.40	0.9	0.4616	0.00	-14.32
Right	0.72	32.83	0.9	0.4616	0.00	-14.32

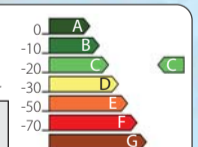

Shield Window, Air, K-glass & Edgetech Super Spacer

Part (see Fig 1)	Δψ m	A m ²	U ₁ W/m ² K	U ₂ W/m ² K	U _p W/m ² K	U _f W/m ² K	Ψ W/m-K	Φ _f W/K
1	1.3665	0.0808	1.1340	1.8093	1.0309	1.4792	0.0280	0.1577
2	0.4945	0.0315	1.1340	1.8093	1.0309	1.4792	0.0280	0.0604
3	0.4945	0.0315	1.1340	1.8093	1.0309	1.4792	0.0280	0.0604
4	1.2785	0.1389	1.2408	1.8088	1.0309	1.6367	0.0265	0.2613
5	0.4505	0.0537	1.1963	1.7673	1.0309	1.5083	0.0274	0.0933
6	0.4505	0.0537	1.1963	1.7673	1.0309	1.5083	0.0274	0.0933
7left	1.3665	0.1786	1.2039	1.8583	1.0309	1.7196	0.0549	0.3797
7right	1.2785				1.0309			
Σ Δψ=	7.1800						Ψ _{av} =	0.0275
Glass	D mm	A m ²	U _g W/m ² K		Φ _g W/K			
Left	28	0.6757	1.7605		1.1897			
Right	28	0.5760	1.7605		1.0140			

Window 'U' - Value = **1.8182 W/m²K**

Domestic Window Energy Rating (DWER)

Pane	g _L	% glass	F _w	g _w	L factor W/m ² K	DWER kWh/m ² /Yr
Left	0.72	38.40	0.9	0.4616	0.00	-23.64
Right	0.72	32.83	0.9	0.4616	0.00	-23.64

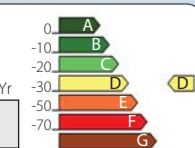
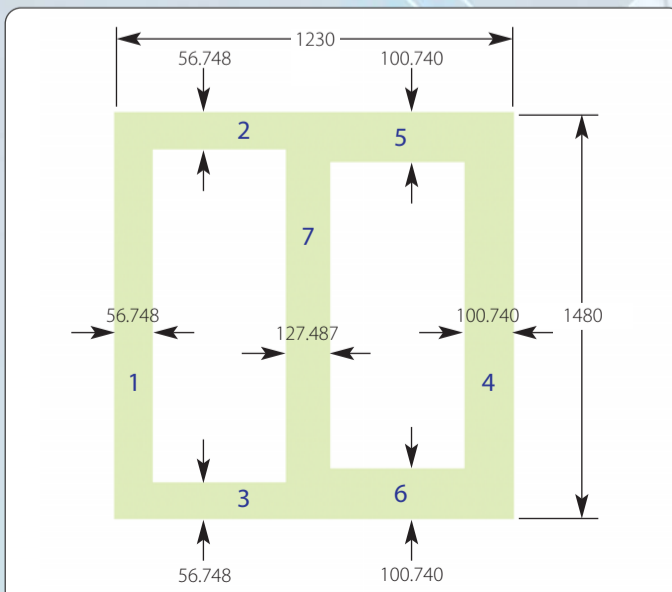

Figure 1.



SAFE WORKING CAPACITIES OF REINFORCEMENTS

(Ref. BPF Publication - Code of Practice for the Survey of PVC-U Windows and Doorsets)

KEY: = ALUMINIUM

Bay-pole Load-bearing Capacity

The load-bearing capacity of a bay pole depends upon two factors:

1. the Least Radius of Gyration,
2. the Effective Length of the pole.

The Least Radius of Gyration is given by:

$$r = \text{square root } (I/A)$$

where I is the moment of inertia (least axis) and A is the cross-sectional area of the pole.

The Effective Length of a pole is determined by the fixings at it's ends. If the pole is held in position at both ends, but not restrained in direction, then the Effective Length is the actual length of the pole (usually the case for most poles).

If the pole is effectively held in position and restrained at both ends, then the Effective Length is only 70% of the actual length (this condition will only apply if the pole is fixed to the structure so that it will not move until the column starts to buckle).

The Slenderness Ratio of the bay pole can then be calculated by dividing the Effective Length by the Least Radius of Gyration. The maximum permissible stress for that length of bay pole can then be obtained from the graph below. The actual load that can be applied is then given by multiplying the allowable stress by the cross-sectional area.

(We have done this for the most commonly used Synseal bay poles and posts, see tables and graphs in this section).

52.5mm dia BAY POLE - RA75

Data supplied by Elliott & Brown - Consulting Civil & Structural Engineers - Nottingham

HEIGHT (mm)	SLENDERNESS RATIO	PERMISSIBLE STRESS (N/mm ²)	CAPACITY (kN)
500	27.9	54.1	15.5
600	33.4	52.3	15.0
700	39.0	50.6	14.5
800	44.6	48.5	13.9
900	50.2	46.7	13.4
1000	55.7	45.0	12.9
1100	61.3	43.3	12.4
1200	66.9	41.5	11.9
1300	72.5	39.8	11.4
1400	78.0	38.0	10.9
1500	83.6	35.9	10.3
1600	89.2	34.2	9.8
1700	94.8	32.4	9.3
1800	100.3	30.7	8.8
1900	105.9	28.6	8.2
2000	111.5	25.8	7.4



SLENDERNESS RATIO AND MAXIMUM PERMISSIBLE STRESS (ALUMINIUM GRADE 6063 T6)

(From BPF Code of Practice for the Survey of PVC-U Windows and Doorsets)

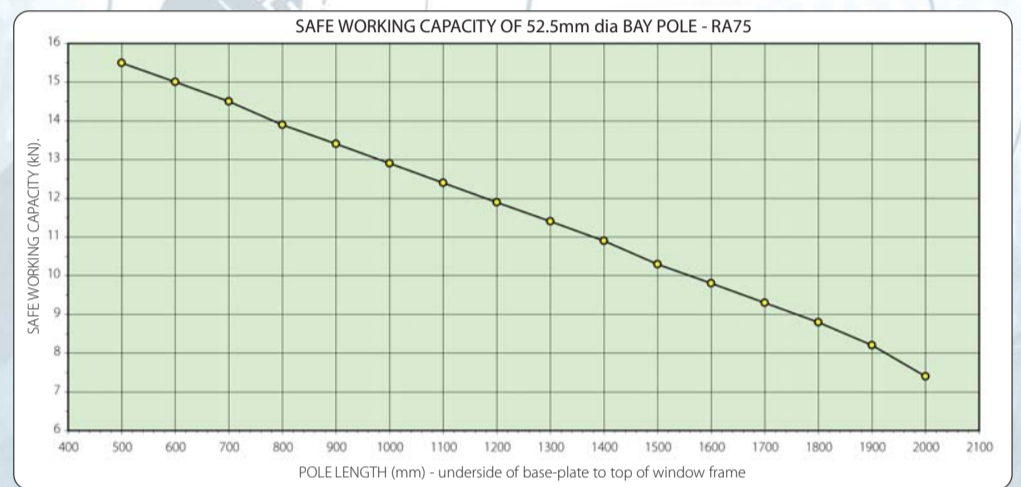

55mm SQUARE BAY POST - SR06

Data supplied by Elliott & Brown - Consulting Civil & Structural Engineers - Nottingham

HEIGHT (mm)	SLENDERNESS RATIO	PERMISSIBLE STRESS (N/mm ²)	CAPACITY (kN)
500	23.5	56.8	21.3
600	28.2	55.3	20.8
700	32.9	53.8	20.2
800	37.6	52.3	19.6
900	42.3	50.8	19.1
1000	46.9	49.3	18.5
1100	51.6	47.8	17.9
1200	56.3	46.3	17.4
1300	61.0	44.8	16.8
1400	65.7	43.2	16.2
1500	70.4	41.7	15.6
1600	75.1	40.2	15.1
1700	79.8	38.7	14.5
1800	84.5	37.2	13.9
1900	89.2	35.7	13.4
2000	93.9	34.2	12.8

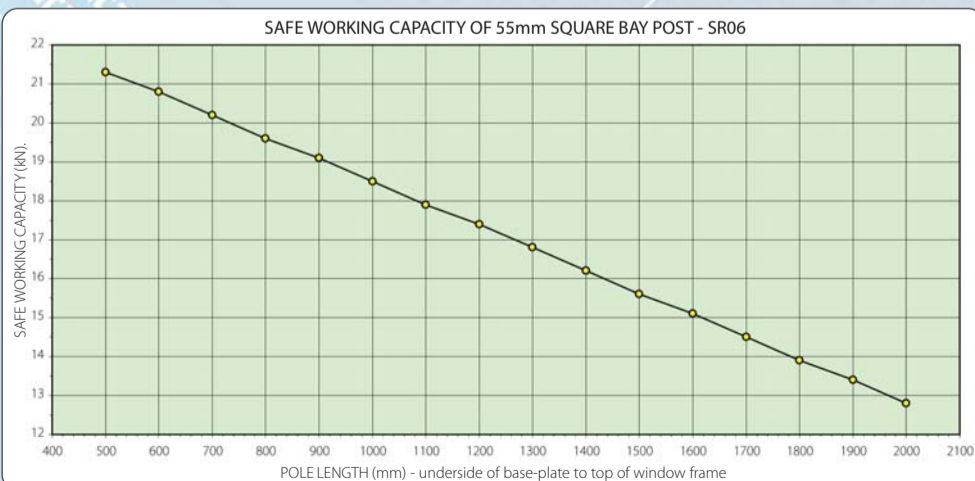

135° CORNER POST - RA135S

Data supplied by Blencowe Associates Ltd - Structural Engineers - Uttoxeter

Material 6063 T6 - Limiting Stress $\sigma_0 = 160\text{N/mm}^2$

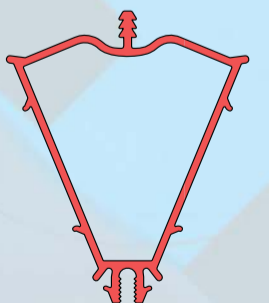
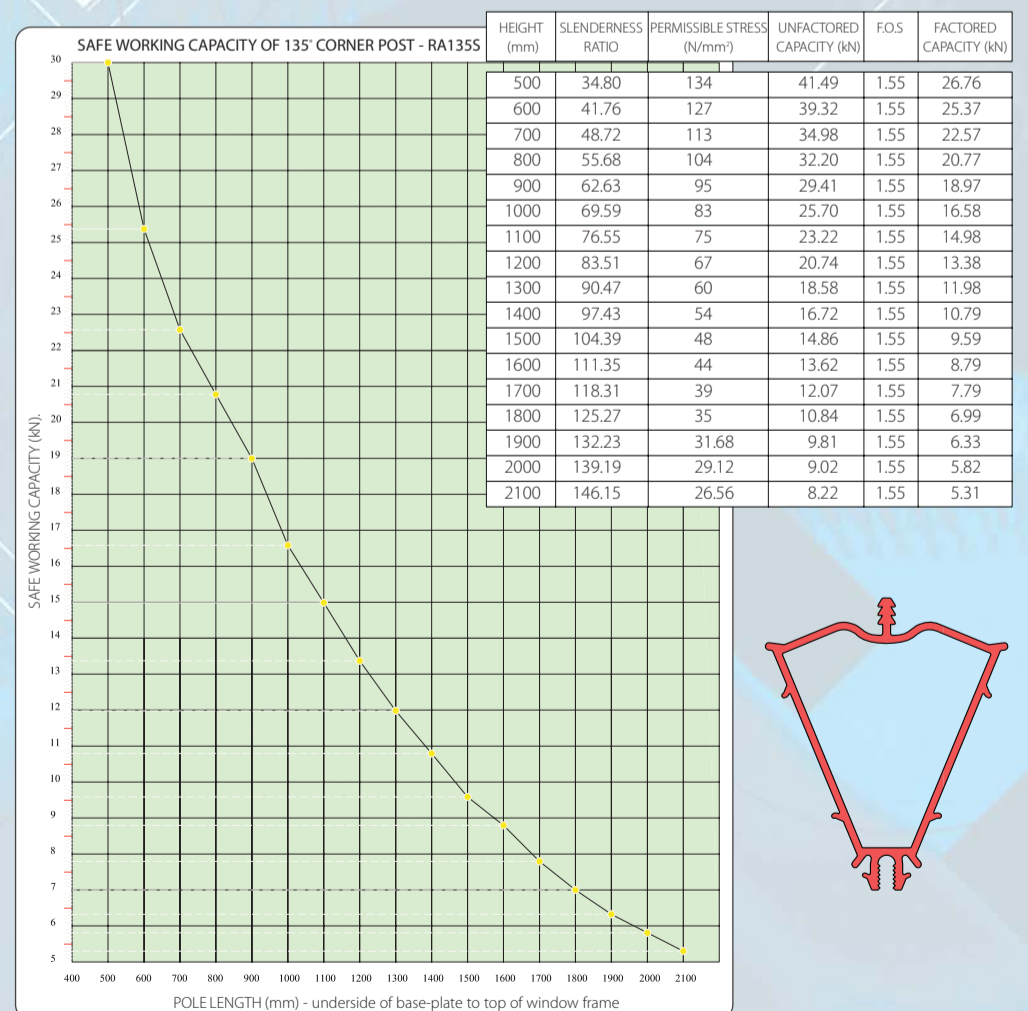

SAFE WORKING CAPACITIES OF REINFORCEMENTS

(Ref. BPF Publication - Code of Practice for the Survey of PVC-U Windows and Doorsets)

KEY: = ALUMINIUM

ALUMINIUM COUPLER - RA76

Data supplied by Blencowe Associates Ltd - Structural Engineers - Uttoxeter

Graph colour key: ● =1.2kN ● =1.6kN ● =2.0kN ● =2.4kN

Information is not applicable to conservatories (outer frame must be fixed to brickwork at either side using standard regulated window industry fixing practices).

None of the calculated maximum panel values include the strength of the two outer frames which will make a contribution to the combined strength.

For wind loading only sections are considered to be laterally restrained by glazing panels and/or transoms.



MAX PANEL WIDTH (mm) @	MULLION HEIGHT (mm)					
	1000	1200	1400	1600	1800	2000
1.2kN ●	5865	4073	2992	2080	1461	1065
1.6kN ●	4398	3055	2244	1560	1096	799
2.0kN ●	3519	2444	1795	1248	877	639
2.4kN ●	2932	2036	1496			

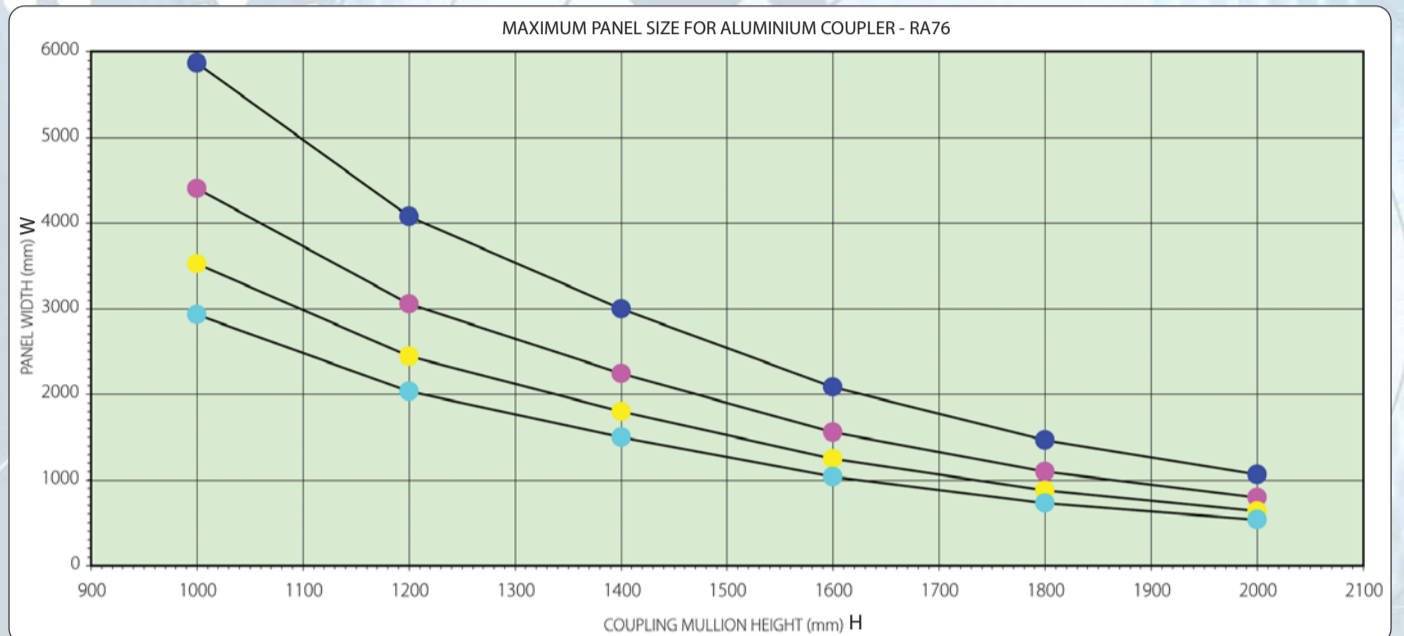
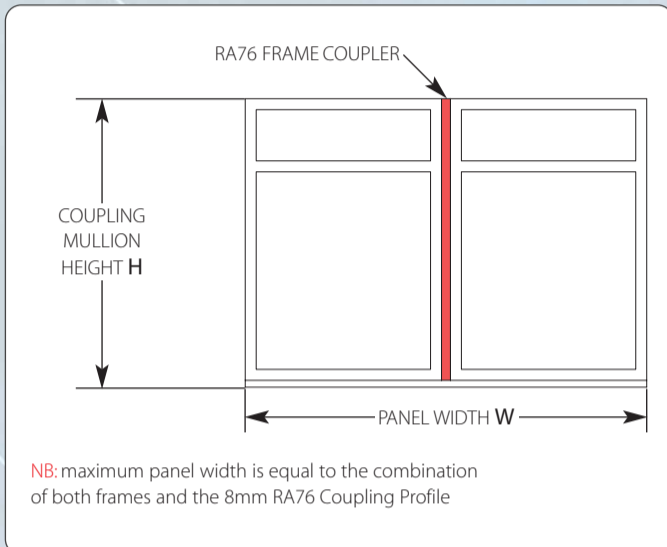

PVC-U WINDOWS IN FIRES

(Information from Tangram Technology Ltd)

Introduction:

PVC-U exhibits excellent fire behaviour and does not burn once the source of heat or flame has been removed.

Building Regulations:

UK Building Regulations do not stipulate any fire performance standards for the material used in window frames. Whilst no degree of 'fire resistance' (as defined by BS 476 part 8) can be achieved by PVC-U window units, the large scale fire tests carried out show no difference between PVC-U and wood under the conditions of test.

PVC-U can, when correctly formulated, achieve high ratings (usually Class 1 surface spread of flame) when performance is assessed to BS 476: parts 6 and 7.

Ignition and burning response:

PVC-U is very difficult to ignite using commonly available ignition sources (match, blow-lamp, etc). Tests with a wide variety of sources varying in heat intensity and impingement area on PVC-U window frames show that the product only burns whilst the source is applied. When the source is removed there is no residual flame on the product. In terms of ignitability, the temperature required to ignite PVC-U is more than 120°C higher than that of pinewood (385°C for PVC-U and 260°C for wood as defined for self ignition.) Once a material has been ignited the flammability can be defined in terms of the Limiting Oxygen Index (LOI) test.

This defines the amount of oxygen that needs to be present for a material to burn freely. A material with an LOI of 21 will burn freely in air (which contains 21% oxygen) and one with an LOI of more than 21 will not burn in air at room temperature.

PVC-U has an LOI of approximately 50, compared with wood at an LOI of 21. This shows that PVC-U will not sustain combustion in air at room temperature and is better than wood in this test.

The limited burning of PVC-U is confirmed in a variety of other standard tests which measure specific parameters, such as rate of heat release and flame spread under different conditions.

The conclusions are clear:

1) the rate of heat release and total heat released by PVC-U are significantly lower than most other building materials.

2) when flames do contact PVC-U, it forms a protective charred layer which insulates the material below and excludes the oxygen necessary for combustion. This restricts the burning zone. In addition, any HCl emitted acts as a combustion inhibitor.

3) PVC-U is very difficult to ignite using common ignition sources.

Smoke and fumes:

Smoke is the result of incomplete burning of a material and consists of solid or liquid particles in the combustion gases. Smoke densities are similar to wood under smouldering conditions, but greater under flaming conditions. The combustion gases (e.g. HCl) may lead to some corrosion of metallic materials but restoration is normally possible. The corrosion gases have no effects on the structural elements of the building. The toxic potency of the combustion gases of PVC-U is similar to, and certainly not significantly worse than, those of many natural materials. The build up of toxic fumes will be slow compared with rapidly burning materials of a similar toxic potency.

The rate of generation and quantity of smoke and fumes produced by a PVC-U window will depend on the severity of the source applied. The smoke and fumes emitted will be confined to the area of the product affected by the source and their transport away from the impingement zone will depend on local factors such as ventilation and survival of the glazing.

In a typical domestic fire the PVC-U window frames will not materially affect the progress of the fire or the possibility of personal injury. Most deaths in fires are caused by smoke or fume inhalation. In a typical domestic fire the occupants are likely to suffer from the inhalation effects from burning carpets, settees, curtains, etc. before the PVC-U in the window frames has even begun to emit smoke or fumes.



Fire resistance:

The fire resistance of a glazed window is mainly influenced by the fracture behaviour of the glazing at high temperature. The fire resistance of glazed PVC-U window frames is generally found to be similar to that of glazed wood window frames.

Large scale fire tests:

In a research programme carried out by the Fire Research Station, the performance of PVC-U window frames in fires was compared with that of traditional wood frames in a typical domestic room. All windows were double glazed and both a large fuel load / non-ventilated controlled fire and a medium fuel load / ventilation controlled fire were used.

The conclusions of the report were;

1) little damage was evident to both PVC-U and wood windows until the glass panes were displaced at approximately 250°C to 400°C. Glass panes failed by cracking and falling out in a random manner.

2) after failure of one glass pane, the increased ventilation changed the mode of the fire and accelerated the fire growth. In most tests the other panes fell out soon after.

3) wood frames burned after the displacement of the glass while the PVC-U window frames softened and the casement sometimes fell out. There was some evidence of combustion of the PVC-U, but PVC-U windows did not show any aspects of performance which would create new hazards in fire involving buildings.

4) carbon monoxide, produced mainly from the wooden fuel under low ventilation conditions, was the major toxic hazard in each test and was produced in volumes that would prove lethal in regions where ambient temperatures would allow survival.

5) the concentrations of carbon monoxide were noticeably lower in the fire involving only PVC-U frames; this was possibly caused by a lower rate of burning in this test.

Summary:

The base PVC-U material has good fire properties and PVC-U windows give a satisfactory performance in fires compared with other materials.

SOUND TRANSMISSION THROUGH WINDOWS

(Ref. Canadian Building Digest, article by J. D. Quirt)



Introduction:

In addition to their primary function as visual openings, windows also transmit sound. This is of concern not only for the exterior surfaces of a building, but also for interior applications ranging from office doors to control booths in recording studios. Sound transmitted through windows often limits the overall acoustical insulation.

Sound transmission through windows is governed by the same physical principles that affect walls, but practical noise control measures are influenced by the properties of glass and the characteristics of the window assemblies. Increasing the glass thickness, for example, gives greater noise reduction at most frequencies, but the stiffness of glass limits the improvement. Using multiple layers (double or triple glazing) increases noise reduction at most frequencies, but this is dependent on the separation of the layers.

As with other building assemblies, transmission of sound through cracks may drastically reduce the effective noise reduction. This is of particular concern for openable windows: even windows with good weather-stripping have reduced noise reduction because of air leakage. Most of the data presented in this report are for sealed windows.

The acoustic terms used in this report are as follows:

decibels (abbreviated to dB.)

Sound Transmission Loss (TL) which is a standardised measure of the noise reduction in decibels for specific frequency ranges.

Sound Transmission Class (STC) is a single figure rating of sound transmission, calculated by fitting a standard contour to the TL data. It is most commonly used in North America.

Sealed single glazing:

The TL for a large thin panel would theoretically increase by 6 dB for each doubling of the sound frequency or the mass if the effect of stiffness was ignored. Although single glazing does approach this 'mass law' behaviour at some frequencies, the stiffness of the glass and the limited size of typical windows cause significant deviations from this prediction (see fig. 1 on page 23).

The sharp decrease in TL at specific frequencies is called the 'coincidence dip', and is caused by bending waves in the glass panel. Above the coincidence frequency, laminated glass can provide much higher TL than solid glass. This is apparently due to damping (dissipation of vibrational energy) by the plastic interlayer.

Sealed double glazing:

The TL of double glazing is strongly dependent on the features of the cavity between the two layers of glass. The STC rating increases as the air space increases (see fig. 2 on page 23). For each doubling of the air space, the STC increases by approximately 3. The STC also increases with increasing glass thickness.

If the separation between the panes is small, the STC rating is only slightly higher than that for a single pane of the same glass. This occurs because the air in the space between the two panes acts like a spring, transferring vibrational energy from one pane to the other. This resonance falls within the range of 200 to 400 Hz for a unit with a small air gap (see fig. 3 on page 23). Most of the energy from aircraft or heavy traffic falls within this frequency range, but by increasing the air space and using heavier glass, the resonant frequency can be lowered to improve the insulation against such noise sources.

Sealed triple glazing:

Despite the widespread belief that adding another layer of glass must be beneficial, triple glazing provides essentially the same noise reduction as double glazing, unless the air gap is very large. Figure 4 (on page 23) compares TL data for a double glazed window with that for a triple glazed window of similar total thickness.

Designing for noise control:

In most cases where substantial noise control is required, double glazing is the most sensible choice. The airspace should be sufficiently large to provide the desired TL.

Using different thicknesses of glass for double glazing gives greater noise reduction. The highest STC values shown in figure 2 are for double 6mm glass; windows with 3mm substituted for one of the 6mm panes would have equal or higher STC ratings.

The use of laminated glass has also been shown to reduce sound transmission.

Figure 1.
Sound transmission loss (TL) for sealed single glazing

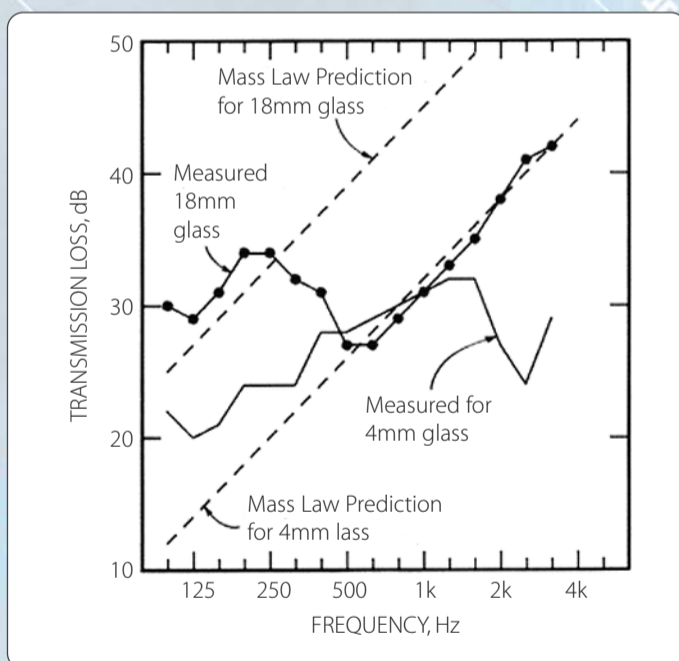

Figure 2.
Sound transmission class (STC) versus interpane spacing for double glazing

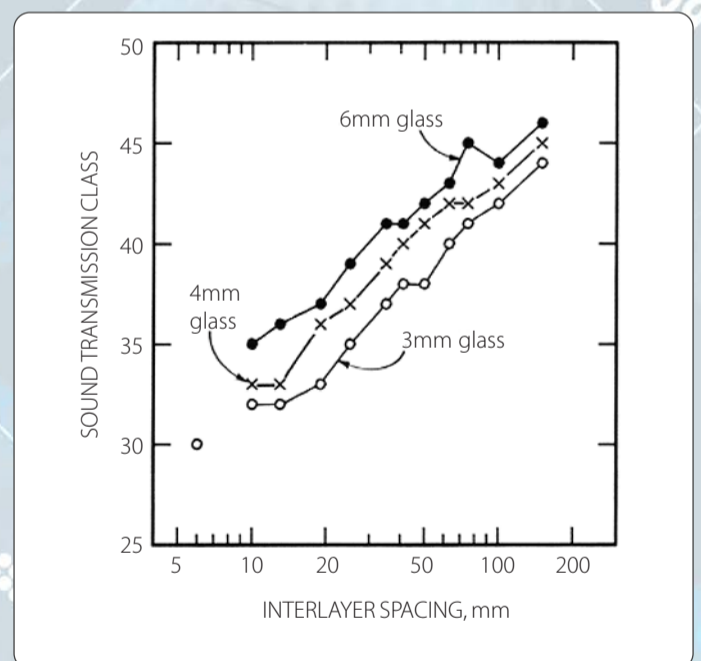

Figure 3.
The effect of a small airspace on TL of double glazing

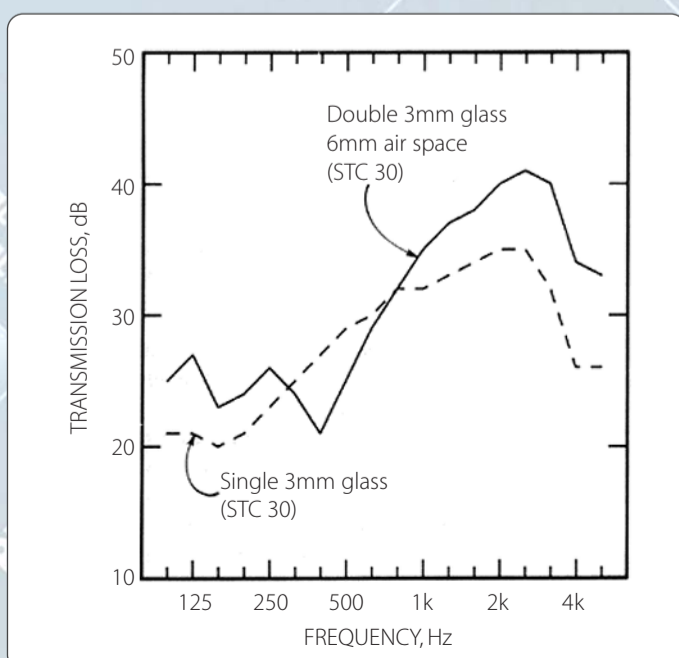
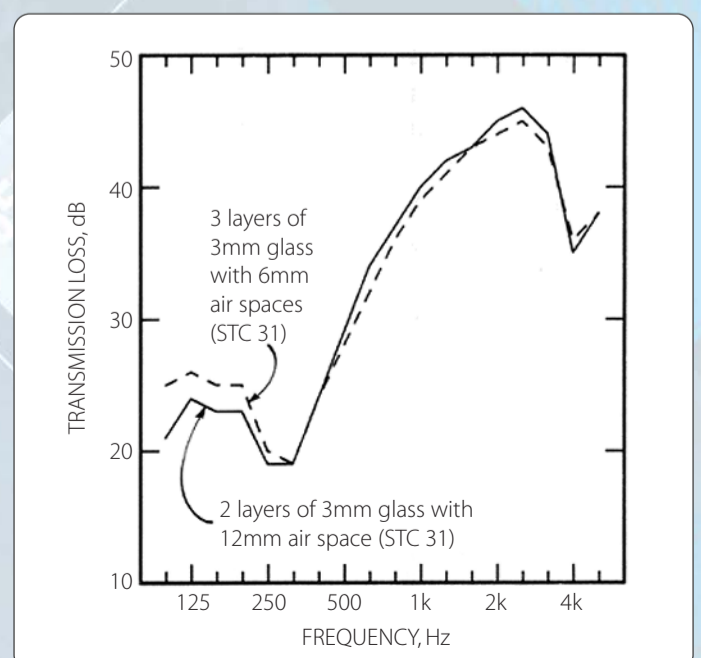

Figure 4.
TL of double and triple glazed windows





Synseal Extrusions Limited, Common Road, Huthwaite, Sutton-in-Ashfield, Notts. NG17 6AD

Tel: (01623) 443200 Fax: (01623) 555330

www.synseal.co.uk

Shield is a Synseal product